

3. Cruise Control Command Switch

A: REMOVAL

WARNING:

Before servicing, be sure to read the notes in the “AB” section for proper handling of the driver’s airbag module. <Ref. to AB-4, CAUTION, General Description.>

- 1) Set the front wheels in straight ahead position.
- 2) Turn the ignition switch to OFF.
- 3) Disconnect the ground cable from battery and wait for at least 20 seconds before starting work.
- 4) Using TORX® BIT T30 (1), loosen the two TORX® bolts which secure driver’s airbag module.

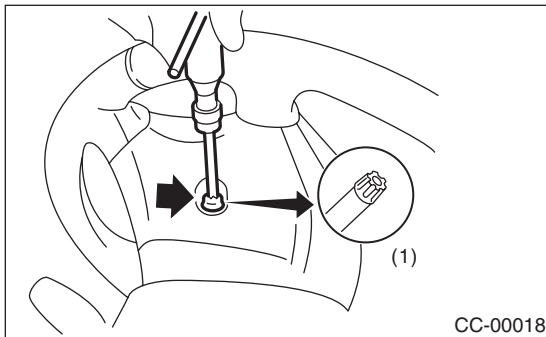

- 5) Disconnect the airbag module connector on back of the airbag module.
- 6) Remove the steering wheel. <Ref. to PS-13, REMOVAL, Steering Wheel.>
- 7) Remove the four screws to remove the lower cover from steering wheel.

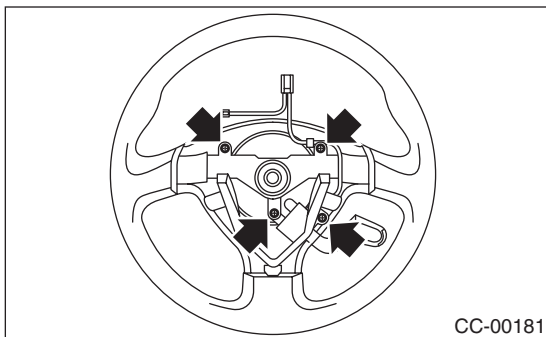

- 8) Remove one screw to remove the cruise control command switch from lower cover.

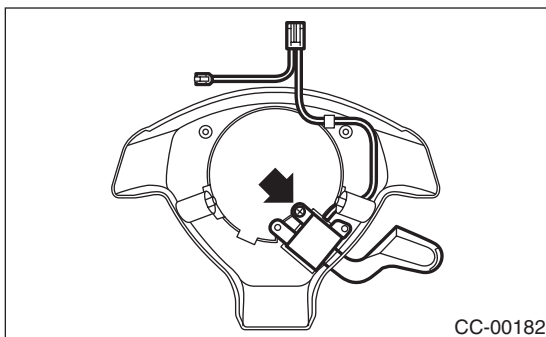

B: INSTALLATION

Install in the reverse order of removal.

C: INSPECTION

Measure the cruise control command switch resistance.

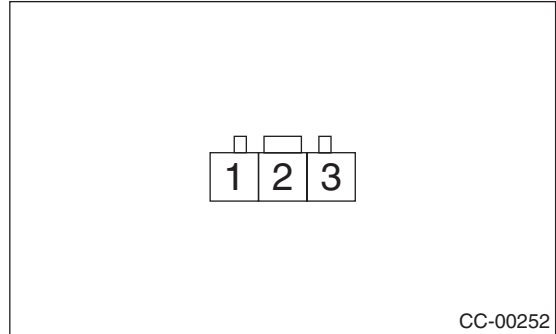

Switch	Position	Terminal No.	Standard value
CANCEL SET/COAST RESUME/ ACCEL	All OFF	2 and 3	Approx. 4 kΩ
CANCEL	ON	2 and 3	Less than 1 Ω
SET/COAST	ON	2 and 3	Approx. 250 Ω
RESUME/ ACCEL	ON	2 and 3	Approx. 1500 Ω
MAIN	OFF	1 and 2	1 MΩ or more
	ON	1 and 2	Less than 1 Ω

If NG, replace the cruise control command switch.