

10. Antenna

A: INSPECTION

Measure the resistance between the antenna terminal and each antenna wire.

If an antenna wire is OK, resistance will be less than 1 Ω . If an antenna wire is broken, resistance will be more than 1 M Ω .

NOTE:

When checking the continuity, wind a piece of aluminum foil around the tip of tester probe and press foil against wire with your finger.

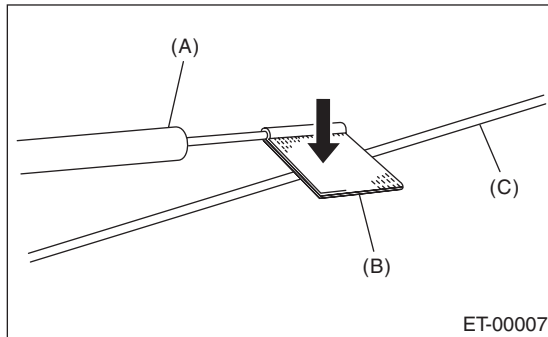

- (A) Tester probe
- (B) Aluminum foil
- (C) Antenna wire

To locate the broken point, move the probe along antenna wire.

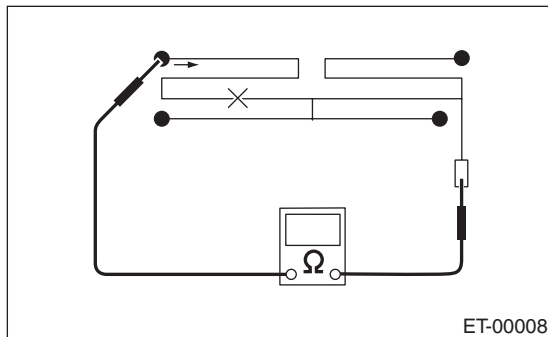

B: REPAIR

- 1) Clean the antenna wire and surrounding area with a cloth dampened by alcohol.
- 2) Paste a thin masking film on the glass along broken wire.
- 3) Apply the conductive silver composition (DUPONT No. 4817 or equivalent) on the broken portion with a drawing pen.

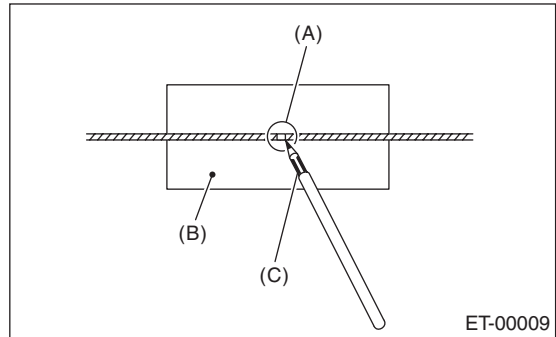

- (A) Broken portion
- (B) Masking film
- (C) Conductive silver composition

- 4) Dry out the deposited portion.
- 5) After repair has been completed, measure the resistance in repaired wire.