

Rear Door

EXTERIOR BODY PANELS

6. Rear Door

A: REMOVAL

- 1) Disconnect the ground cable from the battery.
- 2) Remove the rear door trim. <Ref. to EI-35, REMOVAL, Rear Door Trim.>
- 3) Remove the rear sealing cover. <Ref. to EB-16, REMOVAL, Rear Sealing Cover.>
- 4) Remove the rear door glass. <Ref. to GW-21, REMOVAL, Rear Door Glass.>
- 5) Remove the rear door regulator and motor. <Ref. to GW-23, REMOVAL, Rear Regulator and Motor Assembly.>
- 6) Remove the rear door latch. <Ref. to SL-35, REMOVAL, Rear Door Latch and Door Lock Actuator Assembly.>
- 7) Remove the rear outer handle. <Ref. to SL-34, REMOVAL, Rear Outer Handle.>
- 8) Remove the rubber duct (A) from center pillar, and disconnect the connector of the door harness.

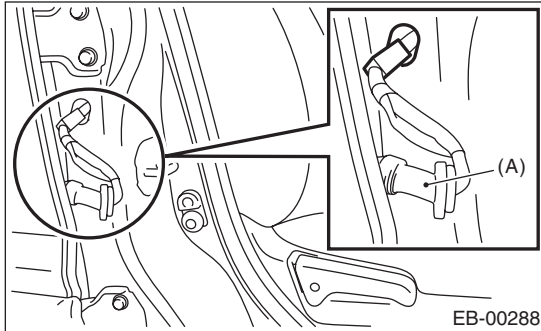

- 9) Put a wooden block on jack and place jack under the door. Support the door with a jack to protect it from damage.

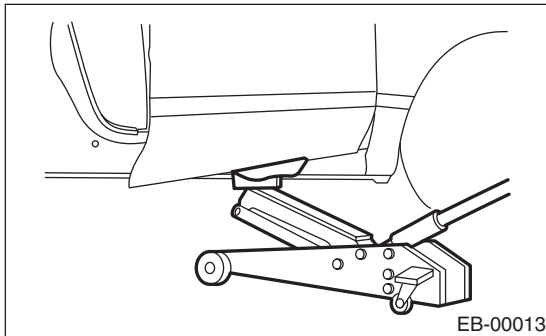

NOTE:

When supporting the door with jack, work carefully so that you do not deform the hinge portion of door during work.

- 10) Remove the checker bolts.

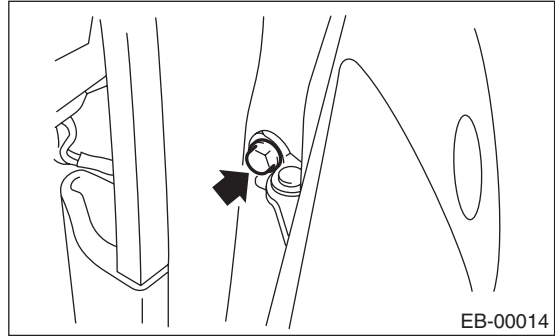

- 11) Remove the door-side bolts for upper and lower hinges to remove the rear door panel.

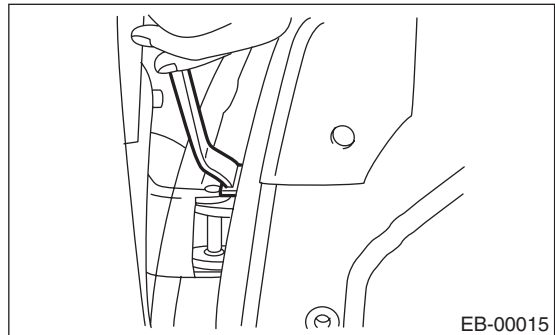

- 12) Remove the attaching bolts (on the body side) for the upper and lower hinges using the ST to remove the door hinges.

ST 925610000 WRENCH

B: INSTALLATION

- 1) Install in the reverse order of removal.
- 2) Apply grease to the moving part of door hinges.
- 3) Refer to "COMPONENT" of "General Description" for tightening torque. <Ref. to EB-6, REAR DOOR, COMPONENT, General Description.>

C: ADJUSTMENT

1) Using the ST, loosen the body-side bolts of the upper and lower hinges to align the position for vertical and horizontal direction of the rear door panel.

ST 925610000 WRENCH



2) Loosen the door-side bolts of the upper and lower hinges to align the position for vertical and horizontal direction of rear door panel on the front side.

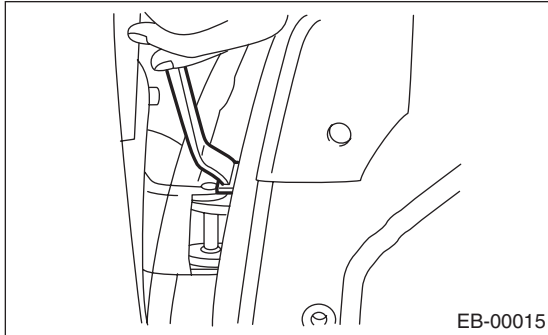

3) Loosen the screws (A) and tap the striker (B) using a plastic hammer to adjust the striker to align the position of rear door panel vertically and laterally at the rear end.

CAUTION:

Do not use an impact wrench. Welding area on the striker nut plate is easily broken.

