

# Diagnostics Chart for Security Indicator Light

IMMOBILIZER (DIAGNOSTICS)

## 8. Diagnostics Chart for Security Indicator Light

### A: INSPECTION

#### 1. CHECK SECURITY INDICATOR LIGHT CIRCUIT

WIRING DIAGRAM:

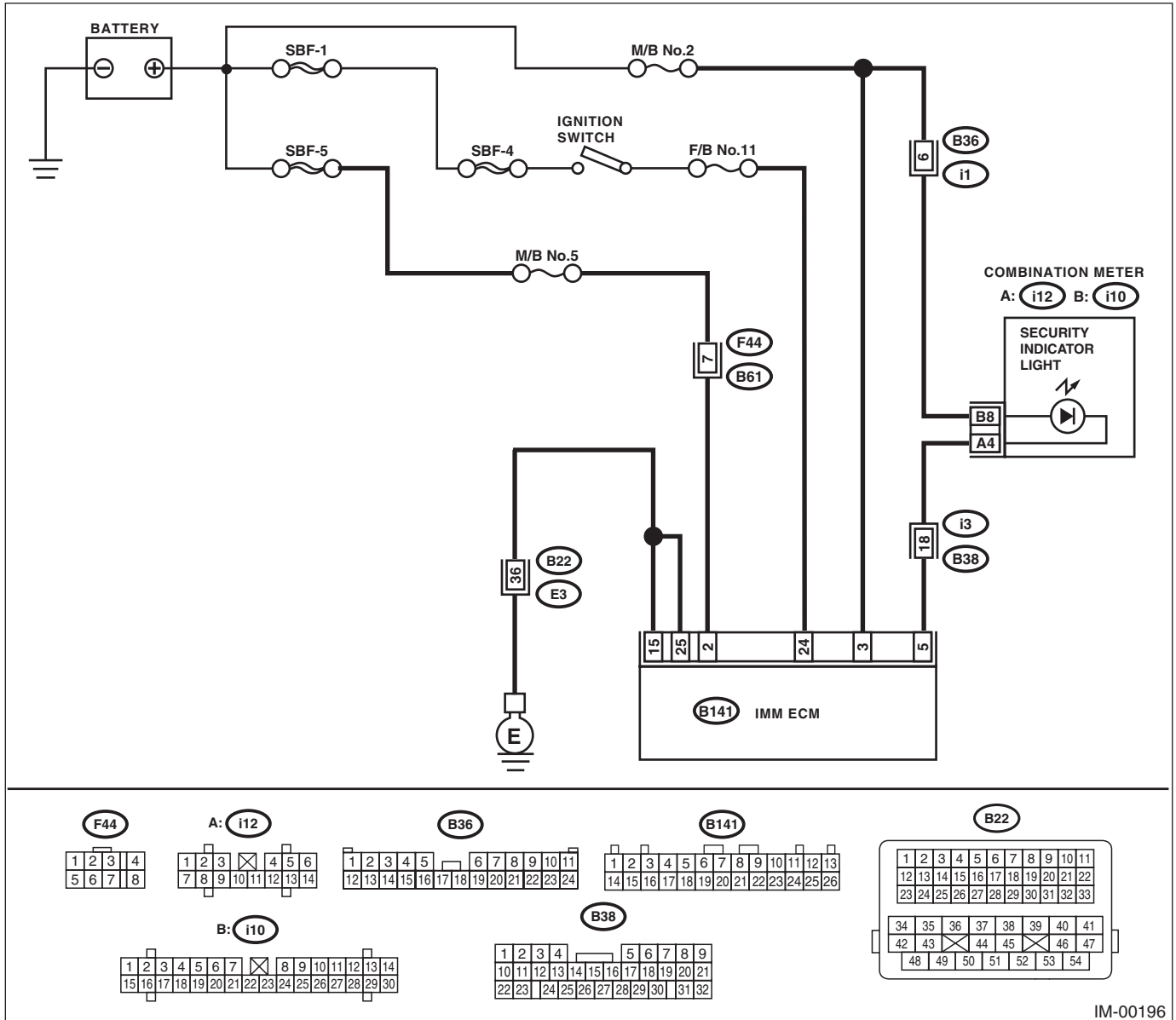

IM-00196

# Diagnostics Chart for Security Indicator Light

IMMOBILIZER (DIAGNOSTICS)

Step	Check	Yes	No
<b>1 CHECK SECURITY INDICATOR LIGHT.</b> 1) Turn the ignition switch to OFF. 2) Disconnect the harness connector from IMM ECM. 3) Connect a resistor (100 Ω) between IMM ECM harness connector terminal No. 5 and chassis ground.	Does the security indicator light illuminate?	Go to step 2.	Go to step 5.
<b>2 CHECK IMM ECM GROUND CIRCUIT.</b> Measure the resistance between IMM ECM harness connector terminal and chassis ground. <i>Connector &amp; terminal</i> <i>(B141) No. 15 — Chassis ground:</i> <i>(B141) No. 25 — Chassis ground:</i>	Is the resistance less than 10 Ω?	Go to step 3.	Repair the open circuit of IMMCM ground circuit.
<b>3 CHECK IMM ECM IGNITION CIRCUIT.</b> 1) Turn the ignition switch to ON. (Engine OFF) 2) Measure the voltage between IMM ECM harness connector terminal and chassis ground. <i>Connector &amp; terminal</i> <i>(B141) No. 24 (+) — Chassis ground (-):</i>	Is the voltage 10 V or more?	Go to step 4.	Check the harness for open or short between IMM ECM and ignition switch.
<b>4 CHECK IMM ECM POWER SUPPLY CIRCUIT.</b> 1) Turn the ignition switch to OFF. 2) Measure the voltage between IMM ECM harness connector terminal and chassis ground. <i>Connector &amp; terminal</i> <i>(B141) No. 2 (+) — Chassis ground (-):</i> <i>(B141) No. 3 (+) — Chassis ground (-):</i>	Is the voltage 10 V or more?	Replace the IMM ECM <Ref. to SL-53, Immobilizer Control Module.> and then replace all ignition keys (including the transponder). Then perform teaching operation. Refer to the "REGISTRATION MANUAL FOR IMMOBILIZER (Pub. No. S0820GZ)".	Check the harness for open or short between IMM ECM and fuse.
<b>5 CHECK COMBINATION METER CIRCUIT.</b> 1) Remove the combination meter. <Ref. to IDI-10, Combination Meter.> 2) Measure the voltage between combination meter harness connector terminal and chassis ground. <i>Connector &amp; terminal</i> <i>(i10) No. 8 (+) — Chassis ground (-):</i>	Is the voltage 10 V or more?	Go to step 6.	Check the harness for open or short between combination meter and fuse.
<b>6 CHECK COMBINATION METER CIRCUIT.</b> Measure the resistance between IMM ECM harness connector terminal and the combination meter harness connector terminal. <i>Connector &amp; terminal</i> <i>(B141) No. 5 — (i12) No. 4:</i>	Is the resistance less than 10 Ω?	Faulty LED. Replace the combination meter print circuit. <Ref. to IDI-11, DISASSEMBLY, Combination Meter.>	Repair the harness or connector.