

Diagnostic Procedure with Diagnostic Trouble Code (DTC)

OCCUPANT DETECTION SYSTEM (DIAGNOSTICS)

13. Diagnostic Procedure with Diagnostic Trouble Code (DTC)

A: DTC 2A ODS CALIBRATION ERROR

DTC DETECTING CONDITION:

System calibration (Rezeroing) was not completed properly.

| | Step | Check | Yes | No |
|---|--|--|-----------------------|--|
| 1 | PERFORM RE-ZEROING. Perform the system calibration using the Subaru Select Monitor. <Ref. to OD(diag)-16, OPERATION, Subaru Select Monitor.> | Is the system calibration completed correctly? | Finish the diagnosis. | Follow the system calibration procedures. <Ref. to OD(diag)-16, OPERATION, Subaru Select Monitor.> |

B: DTC 2B ODS SYSTEM WRONG PARTS

DTC DETECTING CONDITION:

- Wrong airbag control module is installed.
- Wrong occupant detection system is installed.

| | Step | Check | Yes | No |
|---|---|--|-----------------------|--|
| 1 | CHECK OCCUPANT DETECTION SYSTEM. 1) Turn ignition switch OFF, disconnect the battery ground cable, and wait more than 20 seconds. 2) Replace the passenger's seat cushion pad and seat cushion frame assembly. <Ref. to SE-7, REMOVAL, Front Seat.> <Ref. to SE-9, DISASSEMBLY, Front Seat.> 3) Connect the battery ground cable. 4) Connect Subaru Select Monitor to the data link connector and perform the system calibration. <Ref. to OD(diag)-16, OPERATION, Subaru Select Monitor.> | Is the system calibration completed correctly? | Finish the diagnosis. | Go to step 2. |
| 2 | CHECK AIRBAG CONTROL SYSTEM. 1) Turn ignition switch OFF, disconnect the battery ground cable, and wait more than 20 seconds. 2) Replace the airbag control module. <Ref. to AB-16, REMOVAL, Side Airbag Module.> 3) Connect the battery ground cable. 4) Connect Subaru Select Monitor to the data link connector and perform the system calibration. <Ref. to OD(diag)-16, OPERATION, Subaru Select Monitor.> | Is the system calibration completed correctly? | Finish the diagnosis. | Check between the occupant detection control module and airbag control module. |

Diagnostic Procedure with Diagnostic Trouble Code (DTC)

OCCUPANT DETECTION SYSTEM (DIAGNOSTICS)

C: DTC 2C BELT TENSION SENSOR FAILURE

DTC DETECTING CONDITION:

- Passenger's seat belt tension sensor is faulty.
- Airbag main harness circuit is open or shorted.
- Occupant detection control module is faulty.

WIRING DIAGRAM:

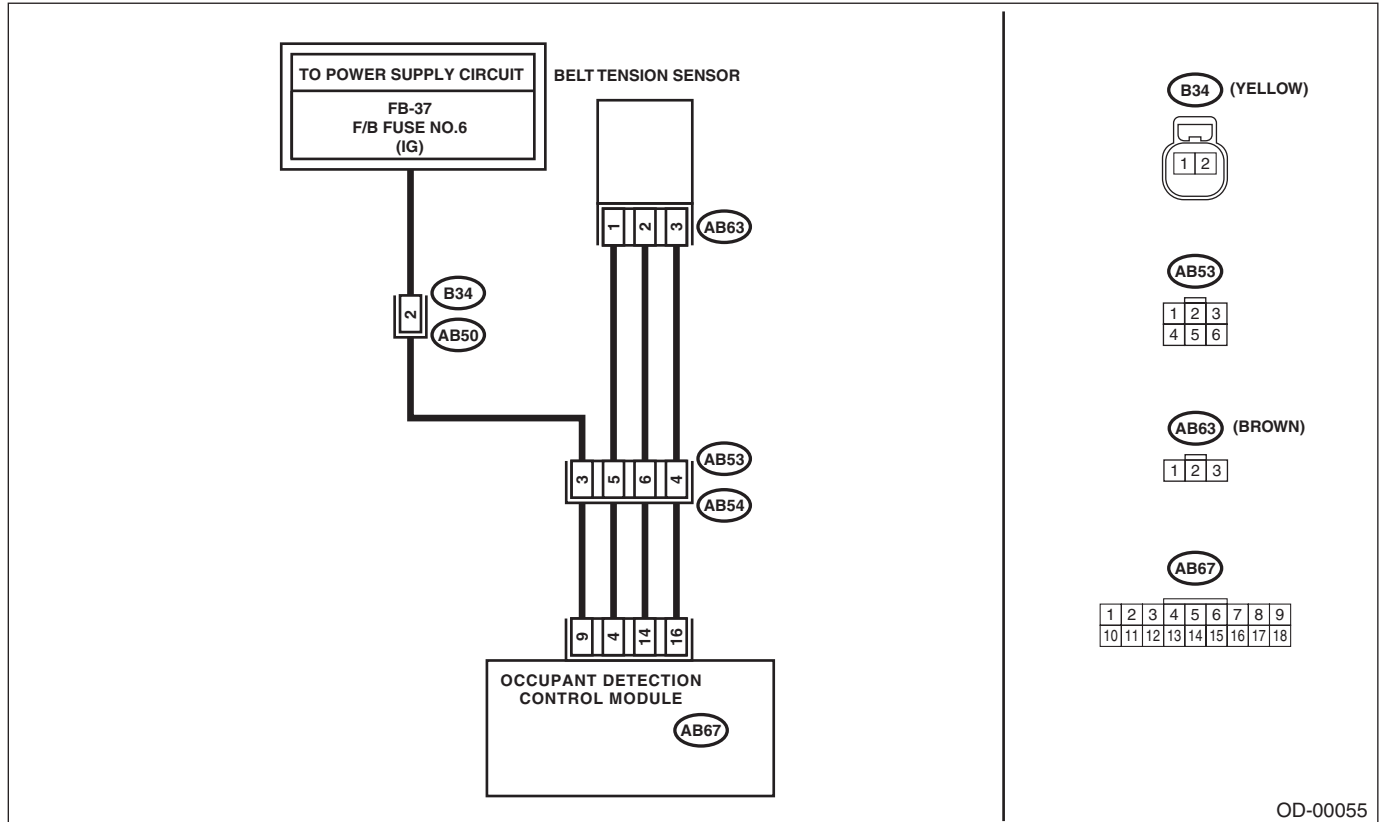

Diagnostic Procedure with Diagnostic Trouble Code (DTC)

OCCUPANT DETECTION SYSTEM (DIAGNOSTICS)

| | Step | Check | Yes | No |
|---|--|--|---|--|
| 1 | <p>CHECK POOR CONTACT OF CONNECTORS. Check for poor contact of the connectors between the occupant detection control module and belt tension sensor.</p> | Is there poor contact? | Reconnect the connector. If the fault is not fixed, replace the airbag harness. | Go to step 2. |
| 2 | <p>CHECK BELT TENSION SENSOR. 1) Turn ignition switch OFF, disconnect the battery ground cable, and wait more than 20 seconds. 2) Disconnect the belt tension sensor connector (AB63) from the airbag harness. 3) Connect the test harness AC to the connector (AB63). 4) Connect the battery ground terminal and turn the ignition switch to ON.</p> | Does the airbag warning light illuminate for approximately 6 seconds and go off? | Replace the seat belt outer. <Ref. to SB-10, REMOVAL, Front Seat Belt.> | Go to step 3. |
| 3 | <p>CHECK AIRBAG HARNESS. 1) Turn ignition switch OFF, disconnect the battery ground cable, and wait more than 20 seconds. 2) Disconnect the test harness AC from the belt tension sensor connector (AB63). 3) Connect the test harness AD (1AD) to the connector (AB63). 4) Disconnect the airbag harness connector (AB62), and connect connector (1AB) of test harness AB. 5) Measure the resistance between test harness terminals. Connector & terminal (2AB) No. 5 — (2AD) No. 1: (2AB) No. 4 — (2AD) No. 3: (2AB) No. 6 — (2AD) No. 2:</p> | Is the resistance less than 10 Ω? | Go to step 4. | Replace the airbag harness. |
| 4 | <p>CHECK AIRBAG HARNESS. Measure the resistance between test harness terminals, and between test harness terminal and chassis ground. Connector & terminal (2AB) No. 4 — (2AD) No. 1: (2AB) No. 4 — (2AD) No. 2: (2AB) No. 4 — Chassis ground: (2AB) No. 5 — (2AD) No. 2: (2AB) No. 5 — Chassis ground:</p> | Is the resistance 1 MΩ or more? | Go to step 5. | Replace the airbag harness. |
| 5 | <p>CHECK AIRBAG HARNESS. 1) Connect the battery ground terminal and turn the ignition switch to ON. 2) Measure the voltage between test harness and chassis ground. Connector & terminal (2AD) No. 1 (+) — Chassis ground (-): (2AD) No. 3 (+) — Chassis ground (-):</p> | Is the voltage 1 V or less? | Replace the airbag harness. | Check the occupant detection harness, and if any fault is found, replace the occupant detection harness. If no fault is found in the occupant detection harness, replace the seat cushion frame assembly. <Ref. to SE-9, DISASSEMBLY, Front Seat.> |

Diagnostic Procedure with Diagnostic Trouble Code (DTC)

OCCUPANT DETECTION SYSTEM (DIAGNOSTICS)

D: DTC 27 ODS COMMUNICATION ERROR

Perform the diagnosis by following diagnostic procedures for the airbag system. <Ref. to AB(diag)-65, DTC 27 ODS COMMUNICATION ERROR, Diagnostic Chart with Trouble Code.>

E: DTC 29 ODS FAILURE

DTC DETECTING CONDITION:

- Occupant detection sensor is faulty.
- Occupant detection control module is faulty.
- Occupant detection harness is faulty.
- Side airbag harness is faulty.
- Fuse No. 6 (in joint box) is blown.

| Step | Check | Yes | No |
|--|--|---|--|
| 1 CHECK POOR CONTACT OF CONNECTOR. Check for poor contact of the connectors between the occupant detection control module and airbag control module. | Is there poor contact? | Reconnect the connector. If the fault is not fixed, replace the airbag harness. | Go to step 2. |
| 2 CHECK DIAGNOSTIC TROUBLE CODE (DTC). Read diagnostic trouble code (DTC) for the airbag system. | Is "2C BELT TENSION SENSOR FAILURE or 37 BUCKLE SWITCH FAILURE" displayed as the diagnostics code? | Perform the diagnosis according to each DTC. | Check the occupant detection harness, and if any fault is found, replace the occupant detection harness. If the fault is not fixed, replace the occupant detection system. <Ref. to SE-9, DIS-ASSEMBLY, Front Seat.> |

Diagnostic Procedure with Diagnostic Trouble Code (DTC)

OCCUPANT DETECTION SYSTEM (DIAGNOSTICS)

F: DTC 37 BUCKLE SWITCH RH FAILURE

DTC DETECTING CONDITION:

- Passenger's seat buckle switch circuit is open, shorted or shorted to ground.
- Seat harness circuit is open, shorted or shorted to ground.
- Occupant detection control module is faulty.

WIRING DIAGRAM:

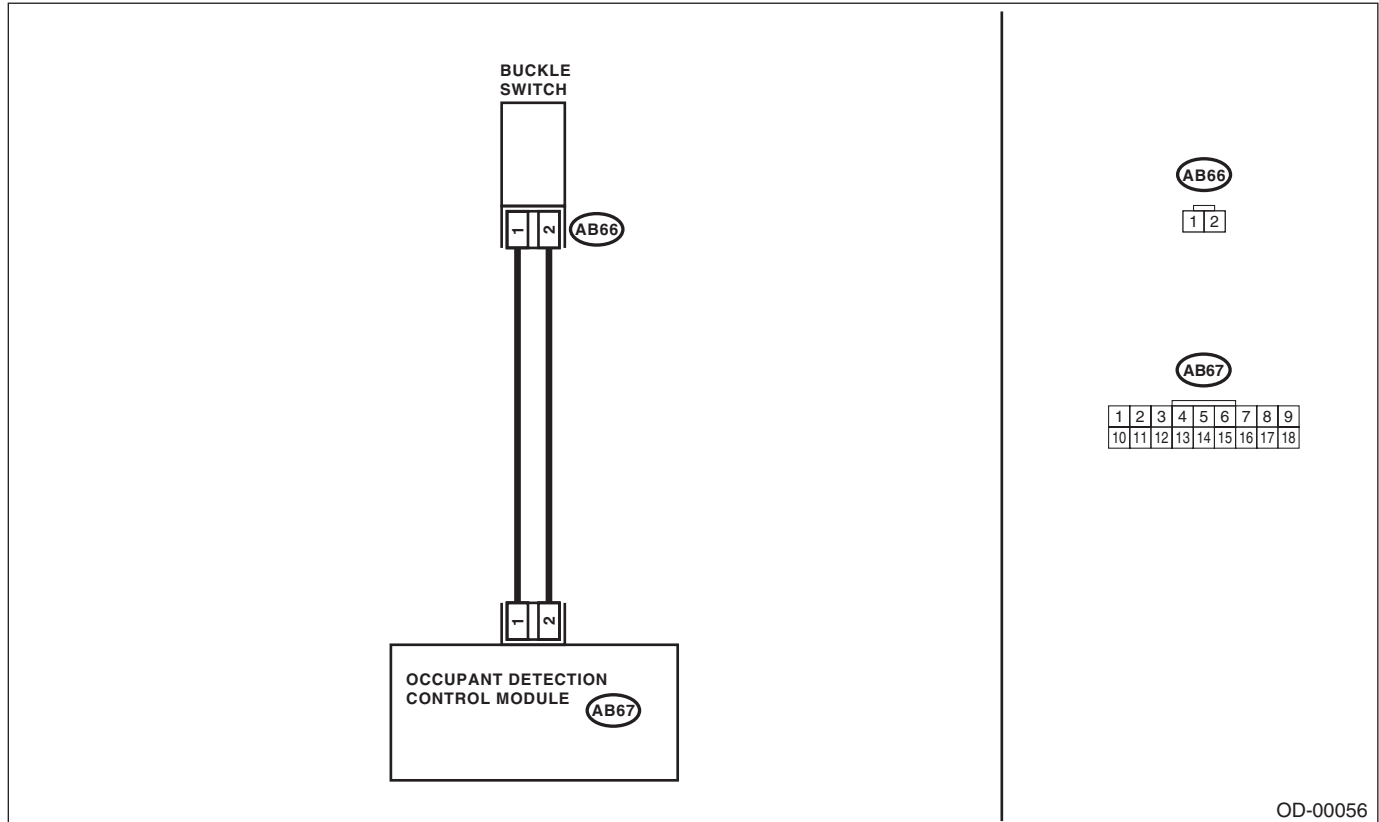

OD-00056

| Step | Check | Yes | No |
|---|--|---|--|
| 1 CHECK POOR CONTACT OF CONNECTOR. Check for poor contact of the connectors between the occupant detection control module and buckle switch. | Is there poor contact? | Reconnect the connector. If the fault is not fixed, replace the airbag harness. | Go to step 2. |
| 2 CHECK BUCKLE SWITCH. 1) Turn the ignition switch to OFF, disconnect the battery ground cable, and wait for more than 20 seconds. 2) Disconnect the buckle switch connector (AB66). 3) Connect the test harness AE (1AE) and test harness connector Y to the buckle switch connector (AB66). 4) Connect the battery ground terminal and turn the ignition switch to ON. | Does the airbag warning light illuminate for 6 seconds and go off? | Replace the buckle switch. <Ref. to SB-10, REMOVAL, Front Seat Belt.> | Check the occupant detection harness, and if any fault is found, replace the occupant detection harness. If the fault is not fixed, replace the occupant detection system. |

Diagnostic Procedure with Diagnostic Trouble Code (DTC)

OCCUPANT DETECTION SYSTEM (DIAGNOSTICS)
