

# General Description

## SECURITY AND LOCKS

### 1. General Description

#### A: COMPONENT

#### 1. DOOR LOCK ASSEMBLY

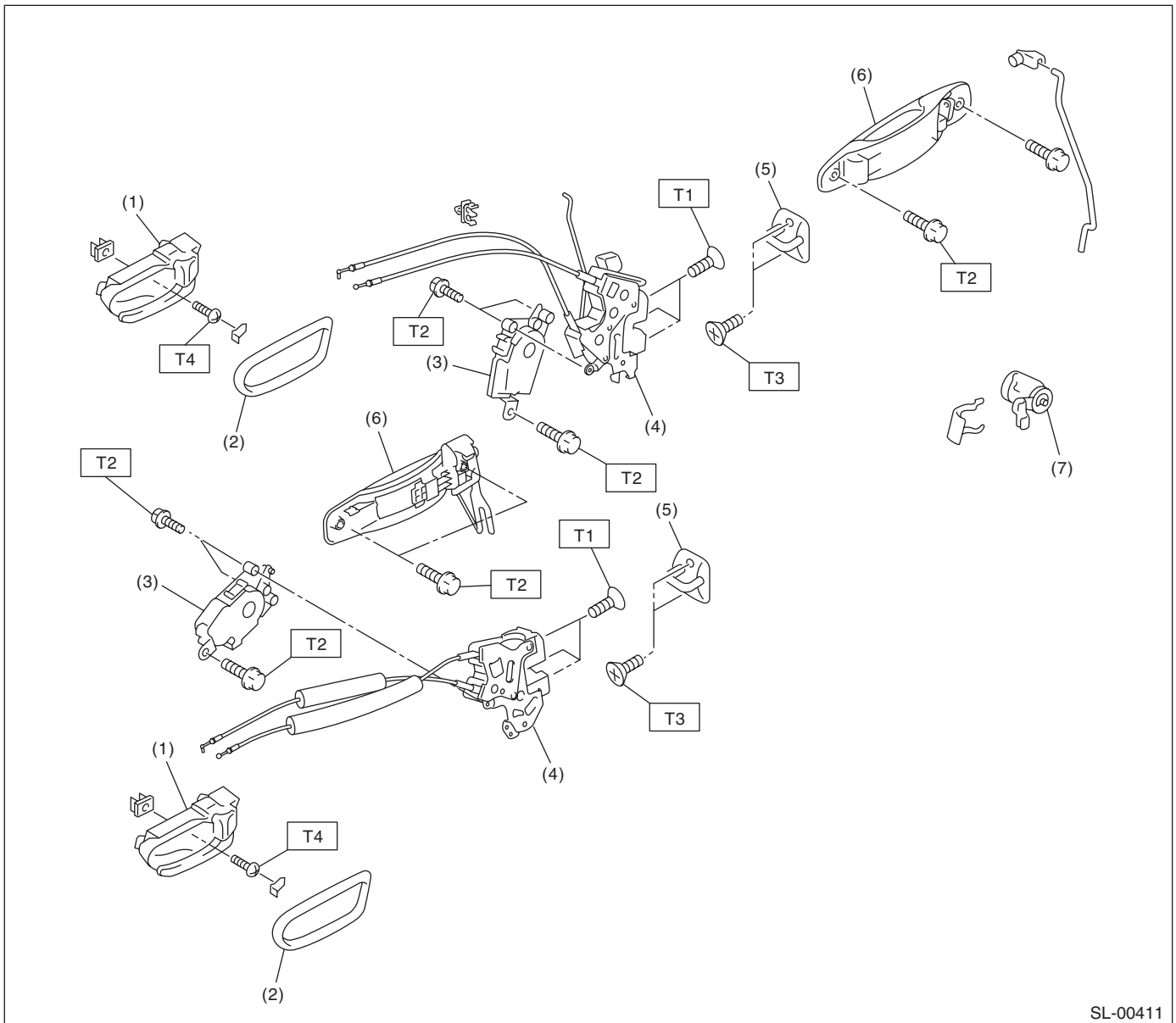

- (1) Inner remote ASSY
- (2) Inner remote cover
- (3) Auto-door lock actuator
- (4) Door latch
- (5) Striker

- (6) Door outer handle
- (7) Key cylinder

**Tightening torque: N·m (kgf·m, ft·lb)**

**T1: 6.5 (0.66, 4.8)**

**T2: 7.5 (0.76, 5.5)**

**T3: 18 (1.8, 13.3)**

**T4: 1.5 (0.15, 1.1)**

## 2. REAR GATE LOCK

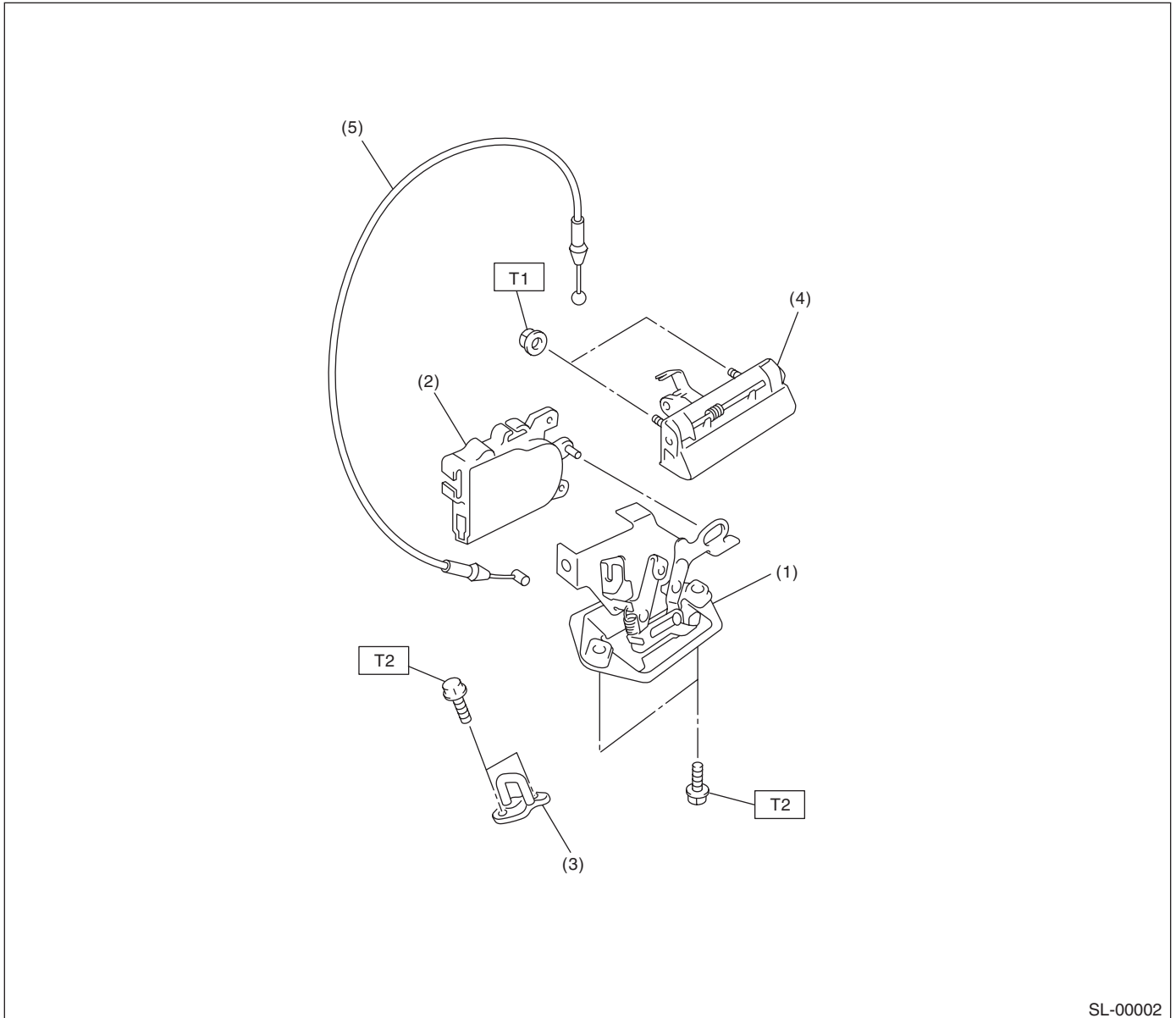

SL-00002

- |                        |                            |
|------------------------|----------------------------|
| (1) Rear gate latch    | (4) Rear gate outer handle |
| (2) Rear gate actuator | (5) Cable                  |
| (3) Striker            |                            |

**Tightening torque: N·m (kgf·m, ft·lb)**

**T1: 7.5 (0.76, 5.5)**

**T2: 25 (2.5, 18.4)**

# General Description

## SECURITY AND LOCKS

### 3. FRONT HOOD LOCK AND REMOTE OPENERS

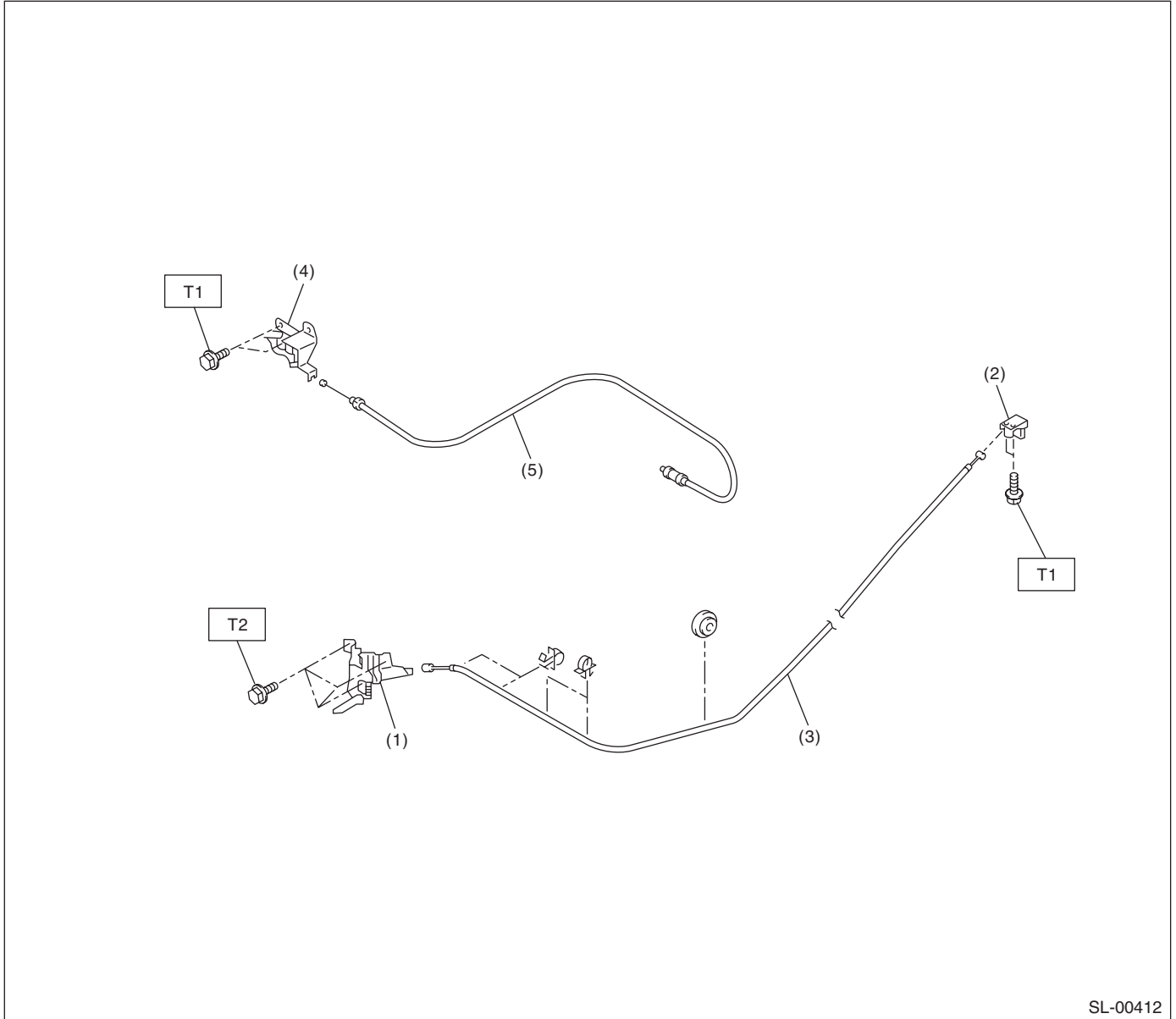

- (1) Front hood lock ASSY
- (2) Lever ASSY
- (3) Front hood cable ASSY

- (4) Pull handle ASSY
- (5) Fuel cable ASSY

**Tightening torque: N·m (kgf·m, ft·lb)**

**T1: 7.5 (0.76, 5.5)**

**T2: 33 (3.4, 24.6)**

### 4. KEYLESS ENTRY SYSTEM

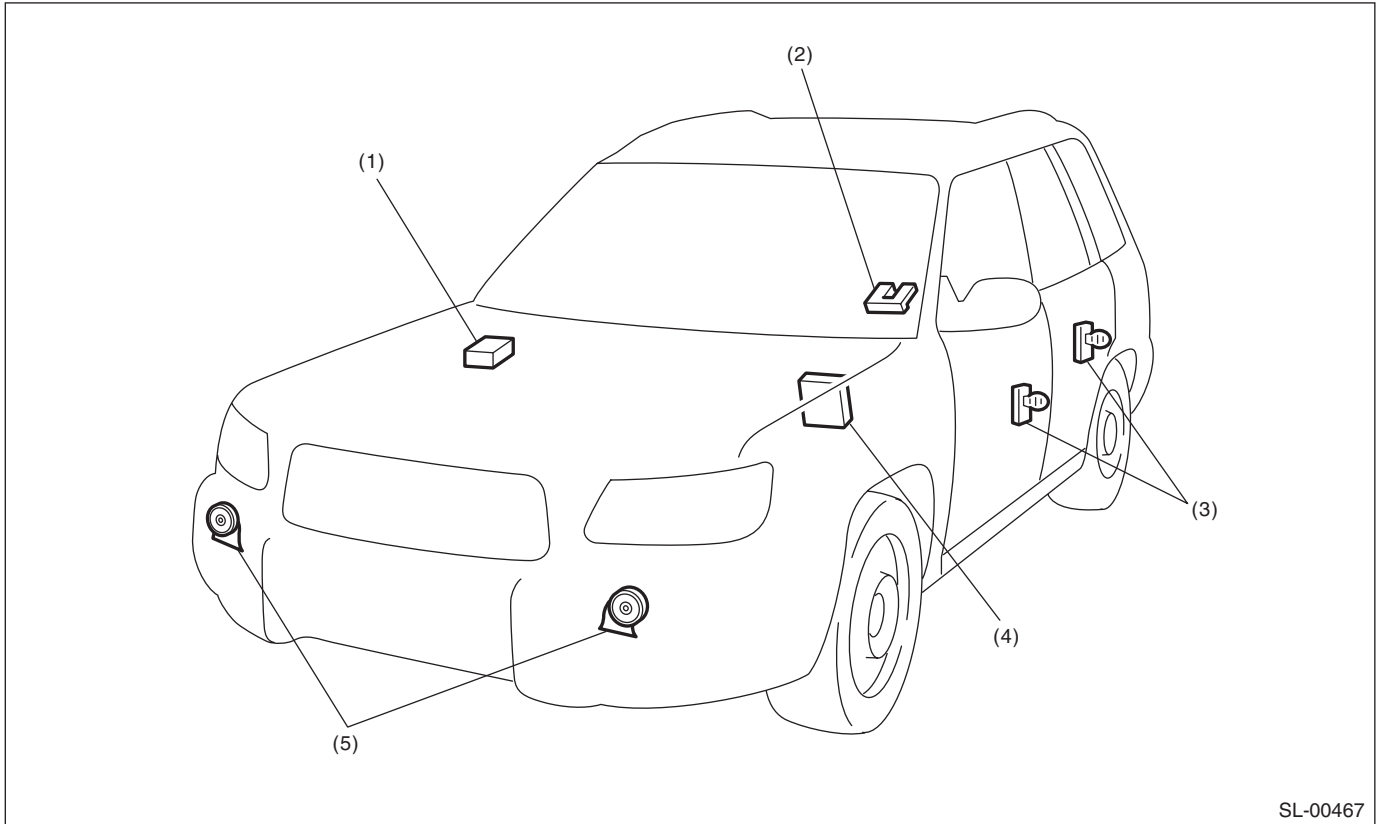

SL-00467

- |                                  |                          |          |
|----------------------------------|--------------------------|----------|
| (1) Keyless entry control module | (3) Door switch          | (5) Horn |
| (2) Rear gate latch switch       | (4) Body integrated unit |          |

### 5. IMMOBILIZER SYSTEM

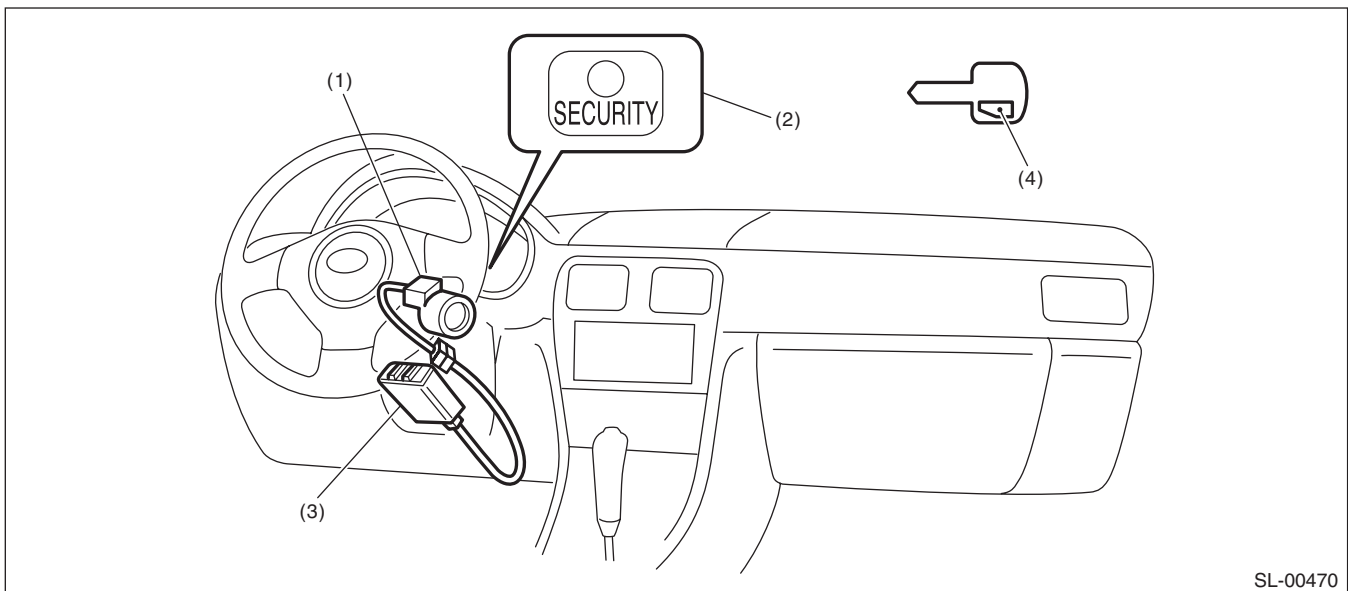

SL-00470

- |                                         |                                        |                 |
|-----------------------------------------|----------------------------------------|-----------------|
| (1) Antenna                             | (3) Immobilizer control module (IMMCM) | (4) Transponder |
| (2) Security indicator light (LED bulb) |                                        |                 |

# General Description

## SECURITY AND LOCKS

### 6. SECURITY SYSTEM

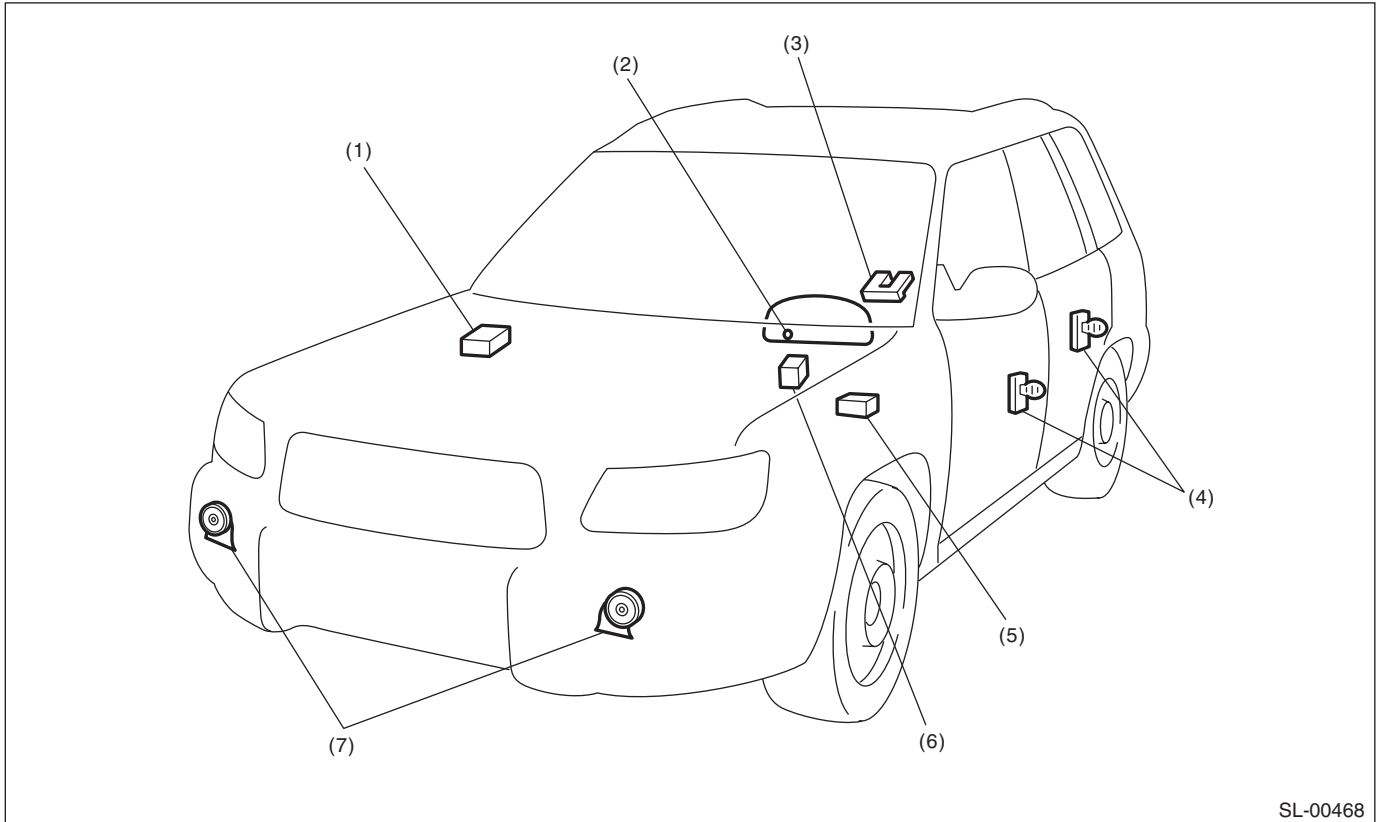

SL-00468

- |                                                     |                            |                                   |
|-----------------------------------------------------|----------------------------|-----------------------------------|
| (1) Keyless entry control module                    | (3) Rear gate latch switch | (6) Horn relay (in main fuse box) |
| (2) Security indicator light (in combination meter) | (4) Door switch            | (7) Horn                          |
| (5) Interrupt relay                                 |                            |                                   |

#### **B: CAUTION**

- Before disassembling or reassembling parts, always disconnect the battery ground cable from battery. When repairing the radio, control module, etc. which are provided with memory functions, record the memory contents before disconnecting the ground cable from battery. Otherwise, these contents are erased upon disconnection.
- Reassemble the parts in the reverse order of disassembly unless otherwise indicated.
- Adjust the parts to the specifications described in this manual if so designated.

- Connect the connectors and hoses securely during reassembly.
- After reassembly, make sure all the functional parts operate smoothly.
- The wiring harnesses of the airbag system pass near electrical parts and switches.
- All the airbag system wiring harnesses and connectors are yellow. Do not use electrical test equipment on these circuits.
- Be careful not to damage the airbag system wiring harness when servicing the ignition key cylinder.

# General Description

SECURITY AND LOCKS

## C: PREPARATION TOOL

### 1. SPECIAL TOOL

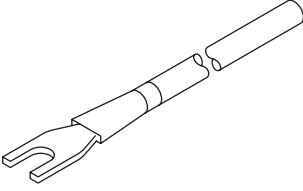
ILLUSTRATION	TOOL NUMBER	DESCRIPTION	REMARKS
 ST-925580000	925580000	PULLER	Used for removing trim clip

### 2. GENERAL TOOL

TOOL NAME	REMARKS
Circuit tester	Used for measuring resistance and voltage.
Drill	Used for replacing ignition key lock.