

14. Rear Gate Latch Assembly

A: REMOVAL

- 1) Disconnect the ground cable from the battery.
- 2) Remove the rear gate trim. <Ref. to EI-47, REMOVAL, Rear Gate Trim.>
- 3) Remove two bolts.

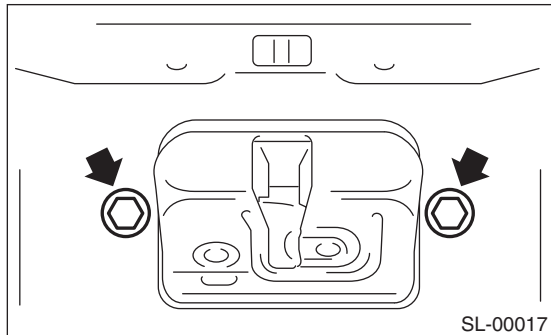

- 4) Remove the rear gate latch assembly and disconnect the connector.
- 5) Remove the rear gate outer handle cable, and then remove the rear gate latch assembly.

B: INSTALLATION

Install in the reverse order of removal.

Tightening torque:

25 N·m (2.5 kgf·m, 18.4 ft·lb)

NOTE:

Make sure the lock works properly after installation.

C: INSPECTION

- 1) Make sure the cable is not deformed.
- 2) Make sure that the lever and cable, rear gate latch switch, and door lock operate smoothly.