

Combination Switch (Wiper)

WIPER AND WASHER SYSTEMS

3. Combination Switch (Wiper)

A: REMOVAL

- 1) Disconnect the ground cable from the battery.
- 2) Remove the instrument panel lower cover. <Ref. to EI-39, REMOVAL, Instrument Panel Assembly.>
- 3) Loosen the screw to remove a steering column lower cover.
- 4) Remove the steering column upper cover mounting screw.

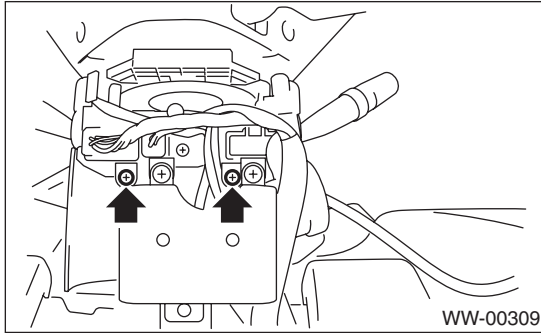

- 5) Disconnect the connector from combination switch.
- 6) Loosen the screw to remove the combination switch.

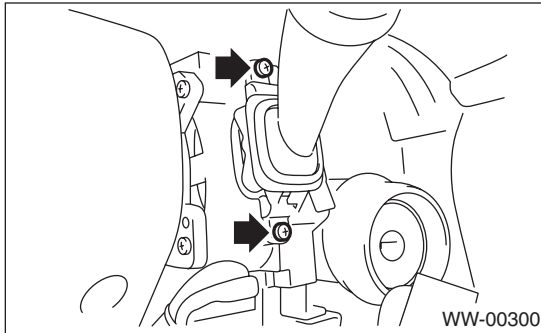

B: INSTALLATION

Install in the reverse order of removal.

C: INSPECTION

- Inspect the continuity between each connector terminal.

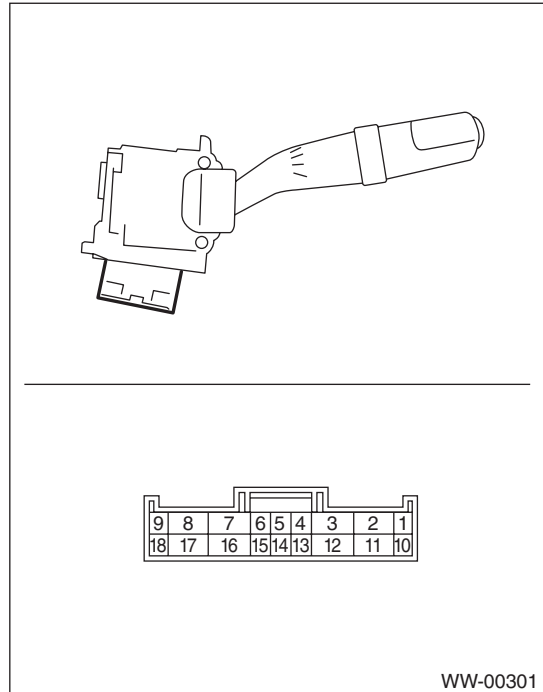

	Switch position	Terminal No.	Standard
Front	LO	7 and 17	Less than 1 Ω
	HI	8 and 17	Less than 1 Ω
	Washer ON	2 and 11	Less than 1 Ω
Rear	Washer ON	2 and 12	Less than 1 Ω
	OFF	Between any two of following terminals: 2, 10, 12, 13	1 MΩ or more
	INT	2 and 13	Less than 1 Ω
	ON	2 and 10	Less than 1 Ω
	Washer ON	2 and 10 10 and 12 2 and 12	Less than 1 Ω

If continuity is not as specified, replace the switch.

- Intermittent operation inspection
- Inspect wiper switch separately
- 1) Set the voltmeter between switch terminal No. 7 (+) and No. 2 (-).
 - 2) Connect the battery between switch terminal No. 17 (+) and No. 2 (-).
 - 3) Turn the front wiper switch to INT.
 - 4) Connect the battery (+) to switch terminal No. 16 for 5 seconds.

Combination Switch (Wiper)

5) Connect battery (–) to switch terminal No. 16 and measure the voltage during intermittent operation.

Terminals

No. 7 — No. 2:

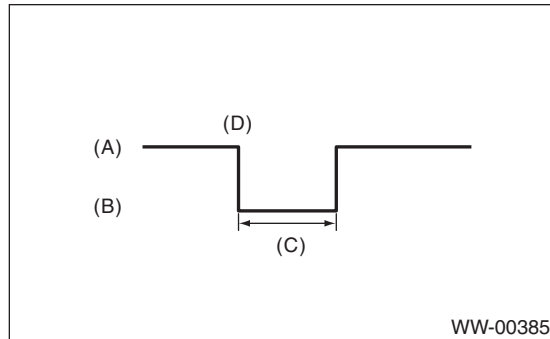

- (A) Approx. 12 V
- (B) Approx. 0 V
- (C) Intermittent stationary time
- (D) Connect battery (–) to terminal No. 16.

6) Perform step 1) to 5) when intermittent control switch is in MIN or MAX.

Intermittent stationary time:

MIN: Approx. 2 sec.

MAX: Approx. 16 sec.

7) If operation is not as specified, replace the switch.