

Wiper Control Relay

WIPER AND WASHER SYSTEMS

12. Wiper Control Relay

A: REMOVAL

- 1) Disconnect the ground cable from battery.
- 2) Remove the quarter lower trim RH. <Ref. to EI-44, REMOVAL, Rear Quarter Trim.>
- 3) Loosen the nut to remove the control unit.

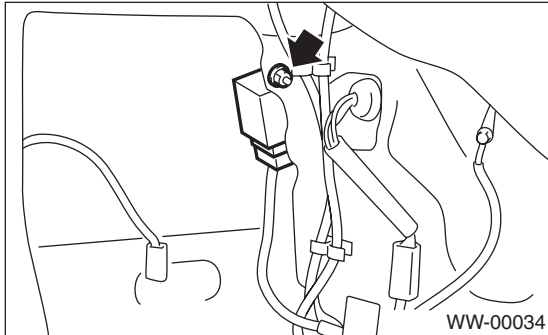

B: INSTALLATION

Install in the reverse order of removal.

C: INSPECTION

- 1) Disconnect the connector from the wiper control relay.
- 2) Connect the positive (+) probe from the battery to terminal 8 and the negative (-) probe to terminal 6. Connect the positive (+) probe from the voltage meter to terminal 3 and the negative (-) probe to the ground.

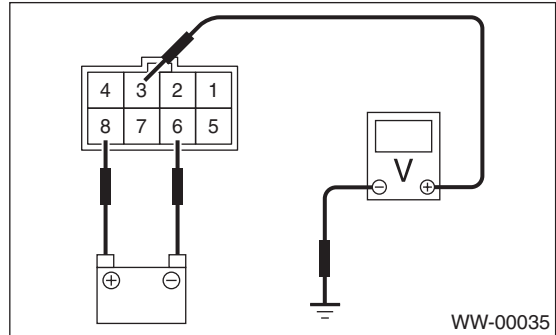

- 3) Measure the voltage when the wiper relay operates.

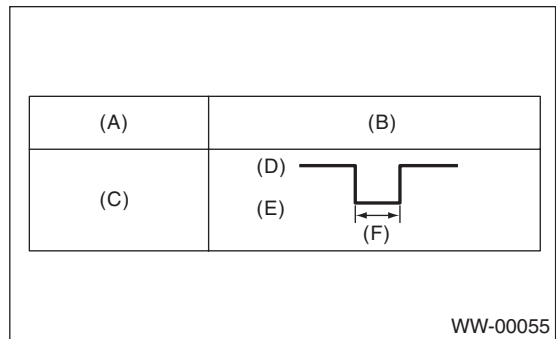

- (A) Switch position
- (B) Voltage
- (C) ON
- (D) 12 V
- (E) 0 V
- (F) 9±2 sec.

If operation is not as specified, replace the switch.