

11. Master Cylinder

A: REMOVAL

CAUTION:

Do not let brake fluid come into contact with the painted surface of the vehicle body. Completely wash away with water immediately and wipe off if it was accidental.

- 1) Drain brake fluid from reservoir tank completely.
- 2) Disconnect the harness connector of the fluid level gauge.
- 3) Remove the brake pipes from master cylinder.
- 4) Remove the master cylinder mounting nuts, and remove the master cylinder from the brake booster.

B: INSTALLATION

- 1) Install in the reverse order of removal.

Tightening torque:

Master cylinder mounting nut
14 N·m (1.4 kgf-m, 10.1 ft-lb)

Piping flare nut
15 N·m (1.5 kgf-m, 10.8 ft-lb)

CAUTION:

Be sure to use recommended brake fluid.

- 2) Bleed air from the brake system. <Ref. to BR-42, PROCEDURE, Air Bleeding.>

C: REPLACEMENT

- 1) Remove mud and dirt from the surface of brake master cylinder.
- 2) Secure the master cylinder in a vise.
- 3) Remove the pin which secures the reservoir tank to master cylinder, and then remove the reservoir tank and grommet.
- 4) Remove the cylinder pin with magnetic pick-up tool while pushing in the primary piston by screwdriver which is wrapped with tape.

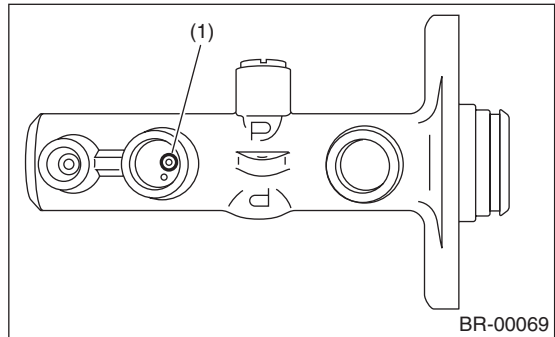

(1) Cylinder pin (straight pin)

- 5) Raise the claw and remove the piston retainer. Hold the piston retainer while working, because the piston may fly out with force.

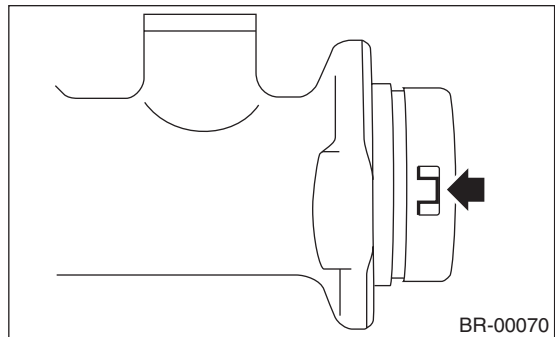

- 6) Extract the primary piston assembly and secondary piston assembly straight out while taking care not to scratch the inner surface of the cylinder.
- 7) Use brake fluid to wash the inside wall of master cylinder and the piston assembly. Check for any damage, deformation, wear or rust. Replace the master cylinder assembly as a unit if faulty.
- 8) Apply brake fluid to the inner surface of master cylinder and piston assembly.
- 9) Make sure that the inner surface of master cylinder and the piston assembly are free of foreign matter. Install the primary piston assembly and the secondary piston assembly to master cylinder, while taking care not to scratch the master cylinder inner surface.
- 10) Install the cylinder pin while pushing in the primary piston by the screwdriver which is wrapped with tape.

11) Install the piston retainer and secure it with the claw.

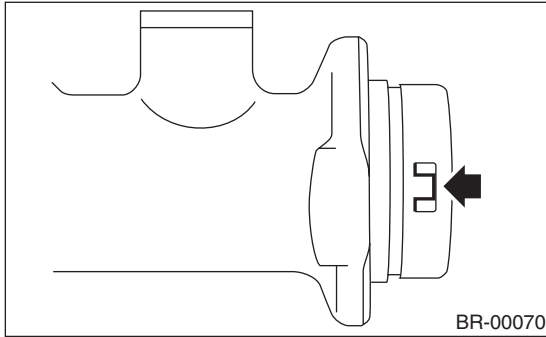

12) Install the seal to reservoir tank.

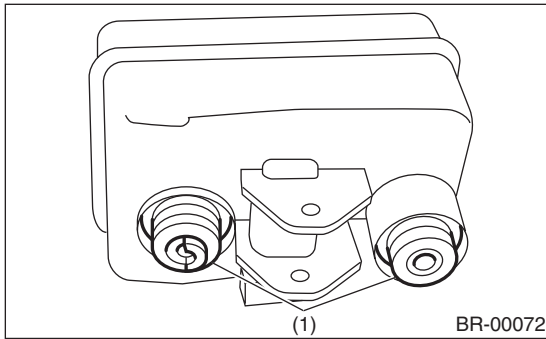

(1) Seal

13) Install the reservoir tank to the master cylinder, and secure with pin.

D: INSPECTION

Check the master cylinder for oil leakage.

NOTE:

After replacing the piston kit, if an oil leakage is found even though there is no damage or scratches on the inside of the cylinder, the master cylinder inner wall may be worn. In this case, replace the master cylinder as an assembly.