

# General Description

## POWER ASSISTED SYSTEM (POWER STEERING)

### 1. General Description

#### A: SPECIFICATION

Model		Non-turbo model	Turbo model	
Whole system	Minimum turning radius	m (ft) 5.4 (17.7)		
	Steering angle (Inside — Outside)	36° 25' — 32° 00'	35° 00' — 30° 54'	
	Steering wheel diameter	mm (in) 375 (14.8)		
	Maximum number of rotations	3.1	3.0	
Gearbox	Type	Integral Rack and Pinion		
	Backlash	0 (Automatic adjusting)		
	Valve (Power steering system)	Rotary valve		
Pump (Power steering system)	Type	Vane pump		
	Reservoir tank	Installed on body		
	Specific output	cm <sup>3</sup> (cu in)/rev. 7.2 (0.439)		
	Relief pressure	6,700 — 7,400 (68 — 75, 970 — 1,070)	7,650 — 8,340 (78 — 85, 1,110 — 1,210)	
	Hydraulic fluid control	Engine speed sensitive		
	Adjusted flow	ℓ (US qt, Imp qt)/min. 1,000 rpm: 6.6 (7.0, 5.8) 3,000 rpm: 5.3 (5.6, 4.7)	1,000 rpm: 7 (7.4, 6.2) 3,000 rpm: 5 (5.3, 4.4)	
	RPM range	670 — 9,869	595 — 8,925	
	Direction of rotation	Clockwise (when observed from pulley side)		
Hydraulic oil (Power steering system)	Description	ATF DEXRON III or equivalent		
	Capacity ℓ (US qt, Imp qt)	Reservoir tank	0.3 (0.3, 0.3)	
		Whole system	0.7 (0.7, 0.6)	
Steering wheel	Free play	mm (in) 17 (0.67)		
Steering angle	Inner wheel	36°25'±1°30'	35°00'±1°30'	
	Outer wheel	32°00'±1°30'	30°54'±1°30'	
Steering shaft	Clearance between the steering wheel and column cover	mm (in) 3.0 (0.118)		
Steering gearbox (Power steering system)	Sliding resistance	N (kgf, lb) 400 (40.8, 89.9) or less		
	Rack shaft play in the radial direction	Right-turn steering	mm (in) 0.19 (0.0075) or less	
		Left-turn steering	mm (in) Horizontal free play: 0.15 (0.0059) or less Vertical free play: 0.3 (0.012) or less	
	Input shaft play	In radial direction	mm (in) 0.18 (0.0071) or less	
		In axial direction	mm (in) 0.5 (0.020) or less	
	Rotation resistance	N (kgf, lb)	Maximum allowance: 9.33 (0.95, 2.10) or less Left and right Difference between right and left sliding resistance: 20% or less	

# General Description

## POWER ASSISTED SYSTEM (POWER STEERING)

Model			Non-turbo model	Turbo model
Oil pump (Power steering system)	Pulley shaft	Free play in the radial direction	mm (in)	0.4 (0.016) or less
		Free play in the axial direction	mm (in)	0.9 (0.035) or less
	Pulley	Ditch deflection	mm (in)	1.0 (0.039) or less
		Rotation resistance	N (kgf, lb)	9.22 (0.94, 2.07) or less
	Regular pressure	kPa (kg/cm <sup>2</sup> , psi)	981 (10, 142) or less	
Steering wheel effort (Power steering system)	At standstill with engine idling on paved road	N (kgf, lb)	31.4 (3.2, 7.1) or less	
	At standstill with engine stalled on paved road	N (kgf, lb)	294.2 (30, 66.2) or less	

Recommended power steering fluid	Manufacturer
ATF DEXRON III or equivalent	B.P.
	CALTEX
	CASTROL
	MOBIL
	SHELL
	TEXACO

**NOTE:**

The table below lists various clearances that must be correctly adjusted to ensure the normal vehicle operation without interference noise, or any other faults. <Ref. to PS-54, INSPECTION OF CLEARANCE, INSPECTION, General Diagnostic Table.>

# General Description

## POWER ASSISTED SYSTEM (POWER STEERING)

### B: COMPONENT

#### 1. STEERING WHEEL AND COLUMN

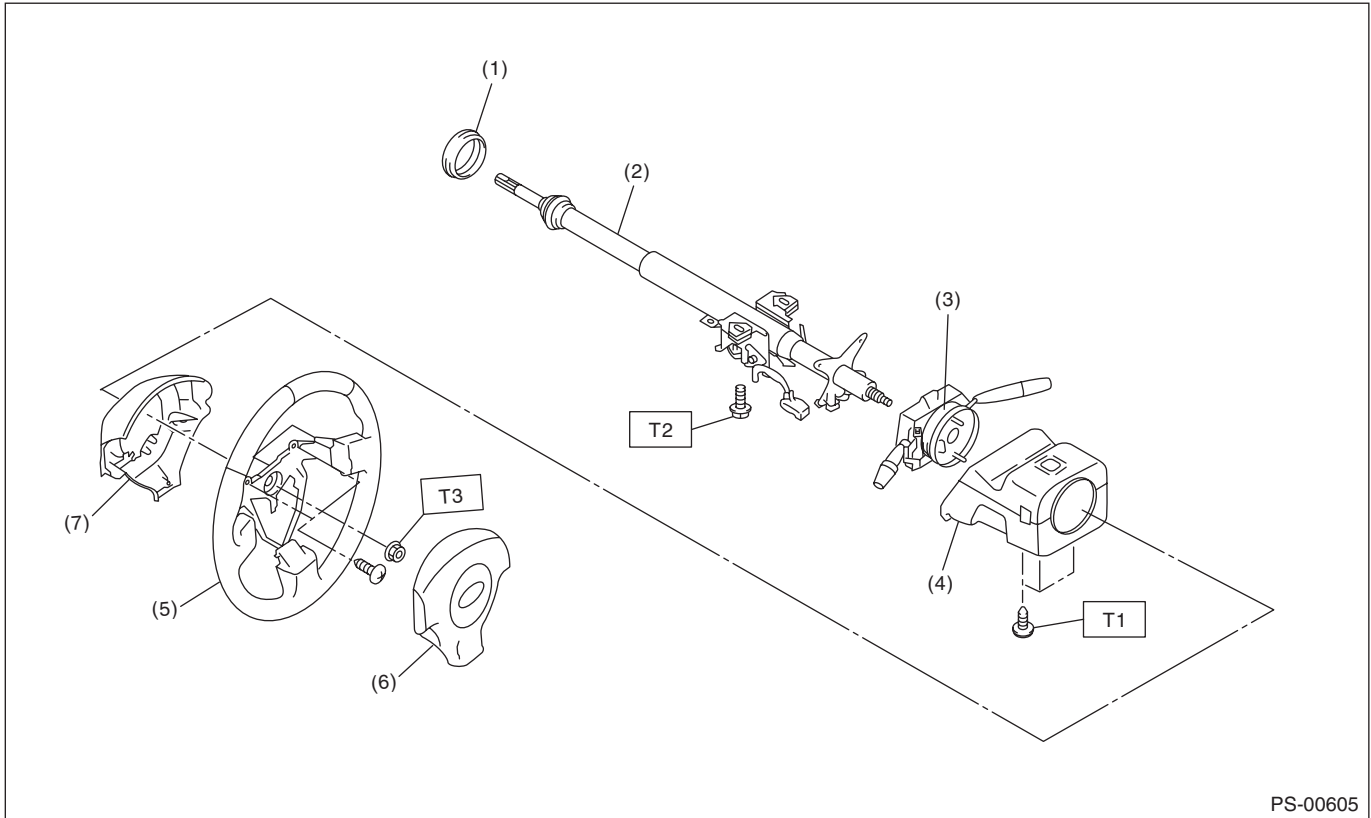

- |                             |                                |
|-----------------------------|--------------------------------|
| (1) Bushing                 | (5) Steering wheel             |
| (2) Steering shaft          | (6) Airbag module              |
| (3) Steering roll connector | (7) Steering wheel lower cover |
| (4) Column cover            |                                |

**Tightening torque: N·m (kgf·m, ft·lb)**

**T1: 1.2 (0.12, 0.9)**

**T2: 25 (2.5, 18.1)**

**T3: 45 (4.6, 33.2)**

# General Description

POWER ASSISTED SYSTEM (POWER STEERING)

## 2. POWER ASSISTED SYSTEM

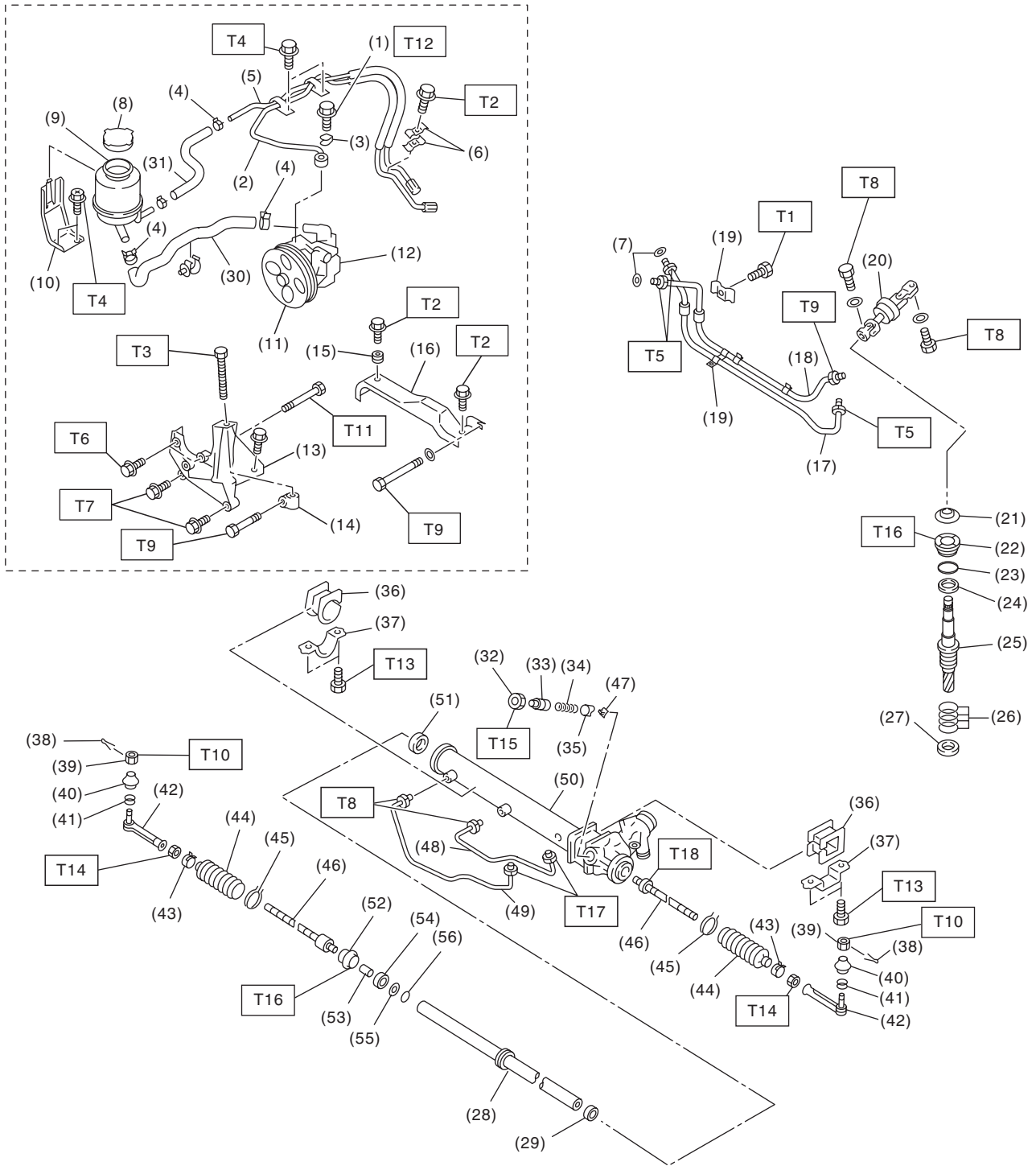

PS-00689

## General Description

### POWER ASSISTED SYSTEM (POWER STEERING)

---

(1) Eye bolt	(27) Oil seal	(52) Holder
(2) Pipe C	(28) Rack	(53) Bushing
(3) Gasket	(29) Back-up washer	(54) Oil seal
(4) Clip	(30) Suction hose	(55) Oil seal
(5) Pipe D	(31) Return hose	(56) O-ring
(6) Clamp E	(32) Lock nut	
(7) O-ring	(33) Adjusting screw	<hr/>
(8) Cap	(34) Spring	<b>Tightening torque: N·m (kgf·m, ft·lb)</b>
(9) Reservoir tank	(35) Sleeve	<b>T1: 6 (0.6, 4.3)</b>
(10) Reservoir tank bracket	(36) Adapter	<b>T2: 7.4 (0.75, 5.4)</b>
(11) Pulley	(37) Clamp	<b>T3: 8 (0.8, 5.8)</b>
(12) Oil pump	(38) Cotter pin	<b>T4: 13 (1.3, 9.4)</b>
(13) Bracket	(39) Castle nut	<b>T5: 15 (1.5, 10.8)</b>
(14) Belt tension nut	(40) Dust cover	<b>T6: 15.7 (1.6, 11.6)</b>
(15) Bushing	(41) Clip	<b>T7: 22 (2.2, 15.9)</b>
(16) Belt cover	(42) Tie-rod end	<b>T8: 24 (2.4, 17.4)</b>
(17) Pipe E	(43) Clip	<b>T9: 25 (2.5, 18.1)</b>
(18) Pipe F	(44) Boot	<b>T10: 27 (2.75, 19.9)</b>
(19) Clamp plate	(45) Boot band	<b>T11: 37.3 (3.8, 27.5)</b>
(20) Universal joint	(46) Tie-rod	<b>T12: 39 (4.0, 28.9)</b>
(21) Dust cover	(47) Sheet pad	<b>T13: 60 (6.1, 44.1)</b>
(22) Plug	(48) Pipe B	<b>T14: 83 (8.5, 61.5)</b>
(23) O-ring	(49) Pipe A	<b>T15: 39 (4.0, 28.9)</b>
(24) Oil seal	(50) Steering body	<b>T16: 64 (6.5, 47.0)</b>
(25) Pinion and valve ASSY	(51) Oil seal	<b>T17: 20 (2.0, 14.5)</b>
(26) Seal ring		<b>T18: 90 (9.0, 65.1)</b>

---

### 3. OIL PUMP

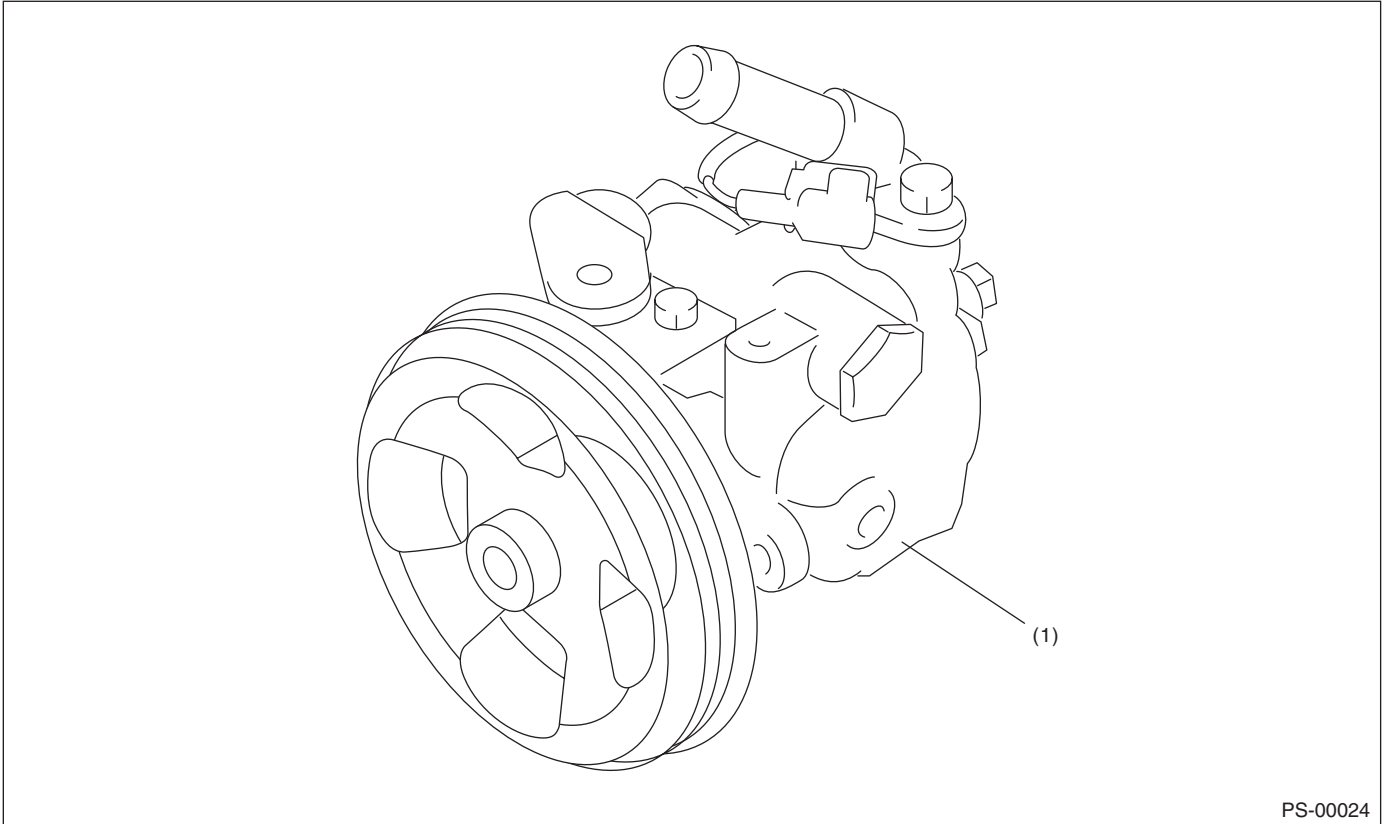

PS-00024

(1) Power steering oil pump ASSY

#### **C: CAUTION**

- Wear appropriate work clothing, including a cap, protective goggles and protective shoes when performing any work.
- Remove contamination including dirt and corrosion before removal, installation or disassembly.
- Keep the disassembled parts in order and protect them from dust and dirt.
- Before removal, installation or disassembly, be sure to clarify the failure. Avoid unnecessary removal, installation, disassembly and replacement.
- Be careful not to burn your hands, because each part on the vehicle is hot after running.
- Use SUBARU genuine power steering fluid, grease etc. or the equivalent. Do not mix fluid, grease etc. of different grades or manufacturers.
- Be sure to tighten fasteners including bolts and nuts to the specified torque.
- Place shop jacks or rigid racks at the specified points.
- Apply power steering fluid onto sliding or revolving surfaces before installation.
- Before installing the O-ring or snap ring, apply a sufficient amount of gear oil to avoid damage and deformation.

- Before securing a part on a vise, place cushioning material such as wood blocks, aluminum plate, or shop cloth between the part and the vise.

## General Description

POWER ASSISTED SYSTEM (POWER STEERING)

### D: PREPARATION TOOL

#### 1. SPECIAL TOOL

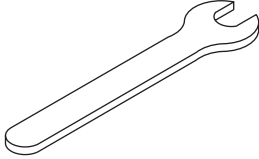
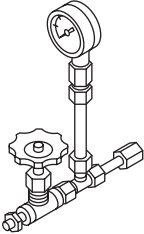
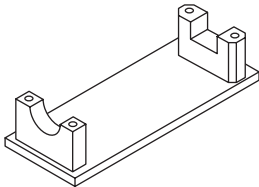
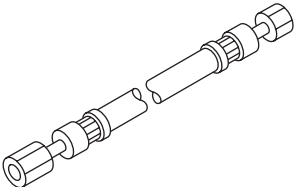
ILLUSTRATION	TOOL NUMBER	DESCRIPTION	REMARKS
 <p style="text-align: center;">ST-925700000</p>	925700000	WRENCH	<ul style="list-style-type: none"> <li>• Used for removing and installing Tie-rod.</li> <li>• Apply this tool to rack.</li> </ul>
 <p style="text-align: center;">ST-925711000</p>	925711000	PRESSURE GAUGE	Used for measuring oil pressure.
 <p style="text-align: center;">ST-926200000</p>	926200000	STAND	Used when inspecting characteristics of the gearbox assembly and disassembly.
 <p style="text-align: center;">ST34099AC010</p>	34099AC010	ADAPTER HOSE A	Used together with PRESSURE GAUGE (925711000).

# General Description

## POWER ASSISTED SYSTEM (POWER STEERING)

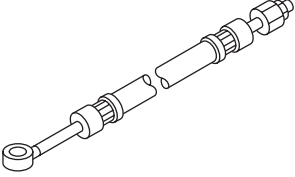
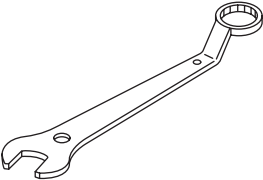
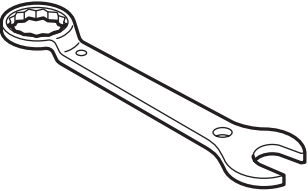
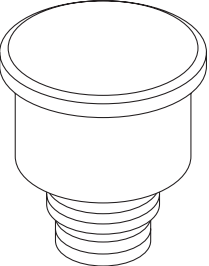
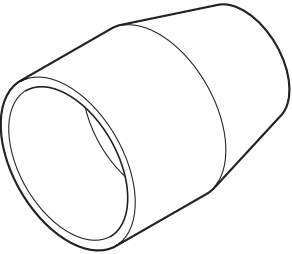
ILLUSTRATION	TOOL NUMBER	DESCRIPTION	REMARKS
 <p data-bbox="326 520 467 541">ST34099AC020</p>	34099AC020	ADAPTER HOSE B	Used together with PRESSURE GAUGE (925711000).
 <p data-bbox="337 871 467 892">ST-926230000</p>	926230000	WRENCH	For the lock nut when adjusting backlash of gear-box.
 <p data-bbox="329 1222 467 1243">ST34099PA100</p>	34099PA100	WRENCH	Used when measuring the rotating resistance of gearbox assembly.
 <p data-bbox="329 1572 467 1593">ST34199AE040</p>	34199AE040	OIL CHARGE GUIDE	Used for charging power steering fluid.
 <p data-bbox="337 1923 467 1944">ST-926250000</p>	926250000	GUIDE	Used for installing the holder assembly into the rack housing.



## General Description

### POWER ASSISTED SYSTEM (POWER STEERING)

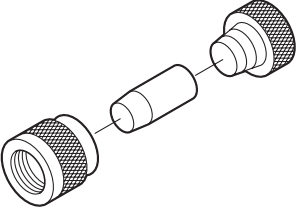
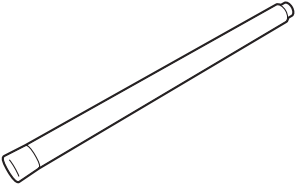
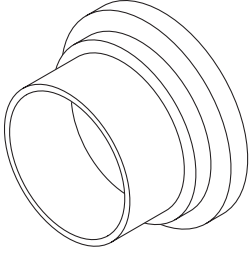
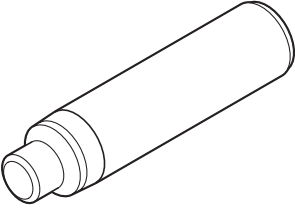
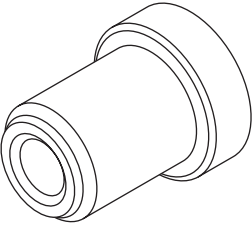
ILLUSTRATION	TOOL NUMBER	DESCRIPTION	REMARKS
 <p style="text-align: center;">ST-927490000</p>	927490000	INSTALLER A, B, C	Used for installing the oil seal to the rack assembly.
 <p style="text-align: center;">ST-927580000</p>	927580000	REMOVER	Used for removing the back-up ring and oil seal.
 <p style="text-align: center;">ST34199AE000</p>	34199AE000	GUIDE	Used for installing the rack and seal into housing assembly.
 <p style="text-align: center;">ST34199FE000</p>	34199FE000	INSTALLER & REMOVER	Used for removing and installing the rack oil seal (outer & inner).
 <p style="text-align: center;">ST34199AE010</p>	34199AE010	INSTALLER	Used for installing the rack oil seal (outer).

# General Description

POWER ASSISTED SYSTEM (POWER STEERING)

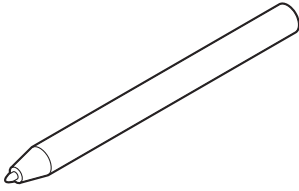
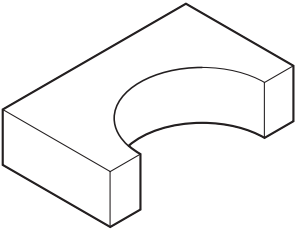
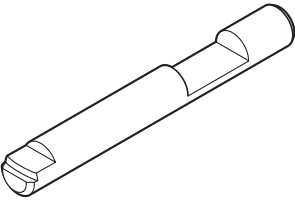
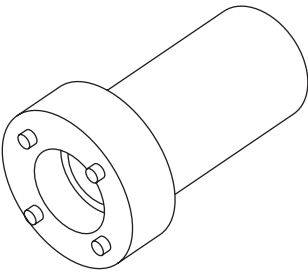
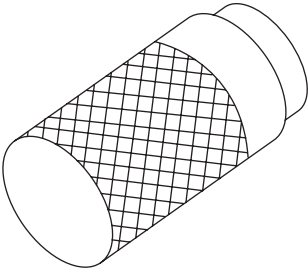
ILLUSTRATION	TOOL NUMBER	DESCRIPTION	REMARKS
 <p data-bbox="326 516 467 541">ST34099FA060</p>	34099FA060	PUNCH HOLDER	Used for crimping.
 <p data-bbox="326 867 467 892">ST34099FA070</p>	34099FA070	BASE	Used for the support housing assembly.
 <p data-bbox="326 1220 467 1245">ST34099FA080</p>	34099FA080	PUNCH	Used for removing crimps.
 <p data-bbox="326 1570 467 1596">ST34199AE090</p>	34199AE090	PLUG WRENCH	Used for removing the plug.
 <p data-bbox="326 1921 467 1946">ST34199AE100</p>	34199AE100	OIL SEAL PLUG REMOVER	Used for removing the oil seal plug.

## General Description

### POWER ASSISTED SYSTEM (POWER STEERING)

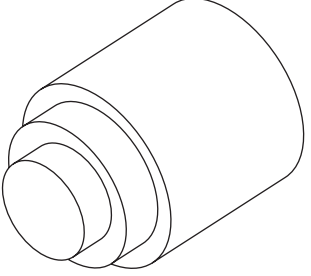
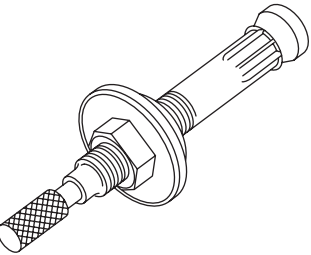
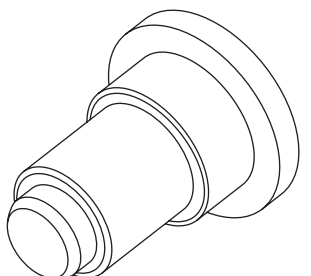
ILLUSTRATION	TOOL NUMBER	DESCRIPTION	REMARKS
 <p style="text-align: center;">ST34199AE110</p>	34199AE110	OIL SEAL PLUG INSTALLER	Used for installing the oil seal plug.
 <p style="text-align: center;">ST34199AE120</p>	34199AE120	GEARBOX OIL SEAL REMOVER	Used for removing the gearbox oil seal.
 <p style="text-align: center;">ST34199AE130</p>	34199AE130	GEARBOX OIL SEAL INSTALLER	Used for installing the gearbox oil seal.

## 2. GENERAL TOOL

TOOL NAME	REMARKS
Spring scale	Used for measuring tightening torque.
Snap ring pliers	Used for removing and installing snap ring.
Dial gauge	Used for measuring the steering gearbox.
Hand clamp pliers	Used for crimping the boot band.
Steering wheel puller	Used for removing the steering wheel.