

# Pipe Assembly

## POWER ASSISTED SYSTEM (POWER STEERING)

### 6. Pipe Assembly

#### A: REMOVAL

- 1) Disconnect the ground cable from the battery.
- 2) Lift-up the vehicle and remove the jack-up plate.

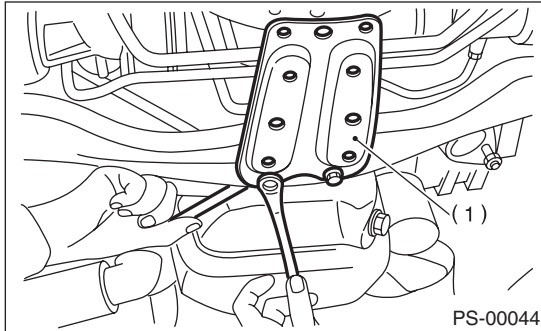

(1) Jack-up plate

- 3) Remove the one pipe joint at the center of gear-box assembly, and connect a vinyl hose to the pipe and the joint. Discharge the fluid by turning the steering wheel fully clockwise and counterclockwise. Discharge the fluid similarly from other pipes.

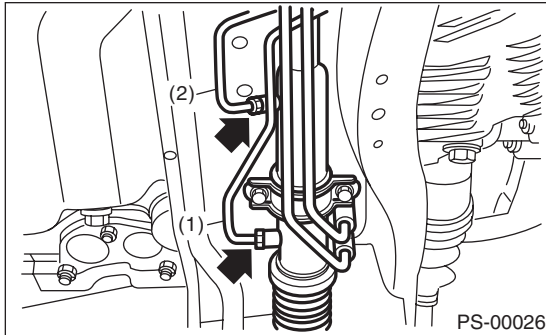

(1) Pipe A  
(2) Pipe B

- 4) Remove the clamp E from pipe C and D.

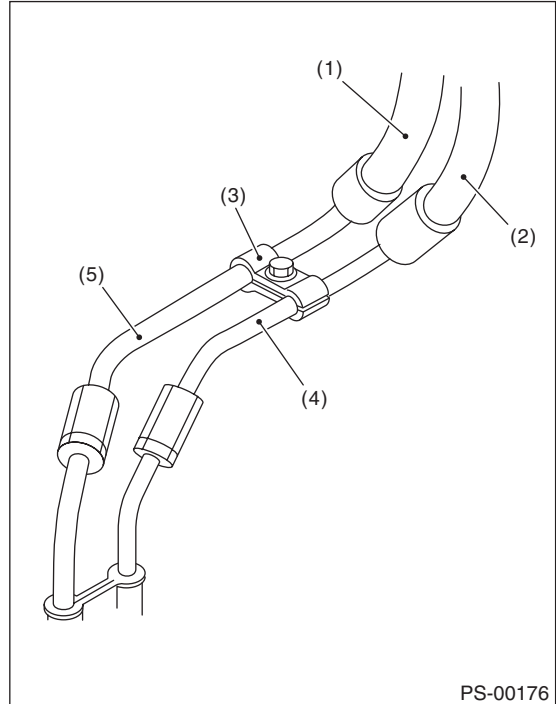

(1) Return hose  
(2) Pressure hose  
(3) Clamp E  
(4) Pipe C  
(5) Pipe D

- 5) Disconnect the pipe C and D from the gearbox.

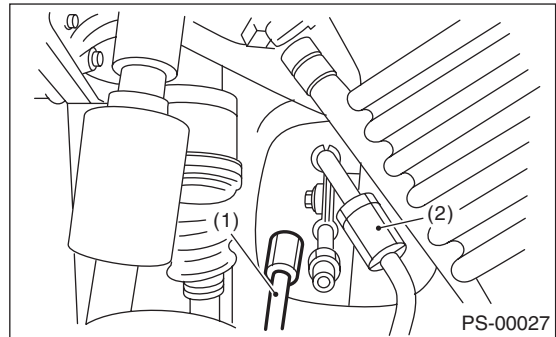

(1) Pipe C  
(2) Pipe D

- 6) Remove the air intake duct. <Ref. to IN (H4SO)-7, REMOVAL, Air Intake Duct.>
- 7) Remove the bolt A.

# Pipe Assembly

POWER ASSISTED SYSTEM (POWER STEERING)

8) Disconnect the pipe C from oil pump. Disconnect the pipe D from the return hose.

## CAUTION:

- Do not allow fluid from the hose end to come into contact with pulley belt.
- To prevent foreign matter from entering the hose and pipe, cover the open ends with clean cloth.

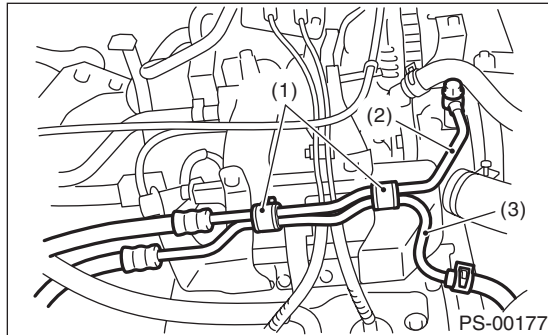

- (1) Bolt A
- (2) Pipe C
- (3) Pipe D

## B: INSTALLATION

1) Temporarily tighten the two bolts (bolts A) fixing pipe C and D in place.

### NOTE:

Visually check that the hose between tank and pipe D is not bent or twisted.

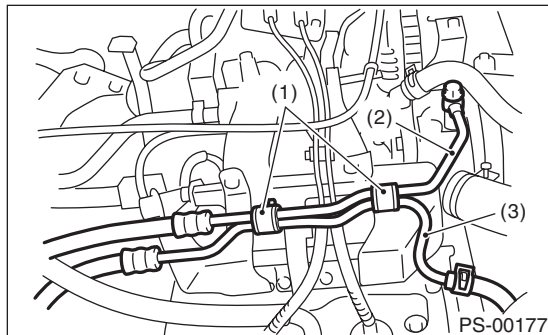

- (1) Bolt A
- (2) Pipe C
- (3) Pipe D

- (1) Connect pipe D to the reservoir tank.
- (2) Install the pipe C to the oil pump using a new gasket.

### Tightening torque:

**39 N·m (4.0 kgf·m, 28.9 ft·lb)**

- (3) Tighten the two bolts (bolts A) fixing pipe C and D in place.

### Tightening torque:

**13 N·m (1.3 kgf·m, 9.4 ft·lb)**

2) Temporarily connect the pipes C and D to the gearbox assembly.

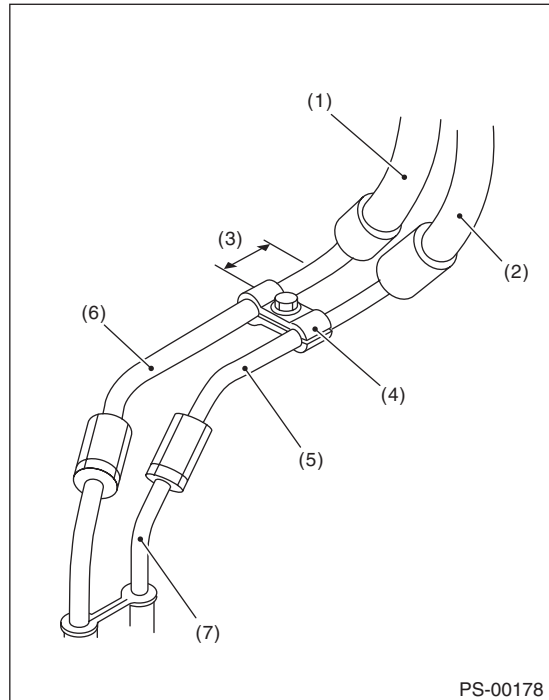

- (1) Return hose
- (2) Pressure hose
- (3) Approx. 30 mm (1.18 in)
- (4) Clamp E
- (5) Pipe C
- (6) Pipe D
- (7) Pipe (on gearbox assembly side)

3) Temporarily install clamp E on pipes C and D.

### NOTE:

Make sure that the character “8” on each clamp is positioned on the same side, as shown in the figure.

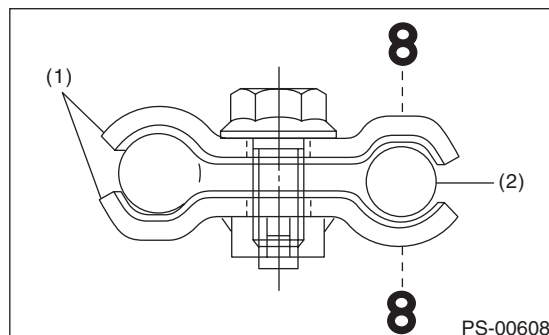

- (1) Clamp E
- (2) Pipe C

4) Tighten the clamp E.

### Tightening torque:

**7.4 N·m (0.75 kgf·m, 5.4 ft·lb)**

# Pipe Assembly

## POWER ASSISTED SYSTEM (POWER STEERING)

5) Tighten the joint nut.

### **Tightening torque:**

**15 N·m (1.5 kgf-m, 10.8 ft-lb)**

6) Connect pipe A and B to the four pipe joints of the gearbox assembly. Connect the upper pipe B first, and lower pipe A.

### **Tightening torque:**

**13 N·m (1.3 kgf-m, 9.4 ft-lb)**

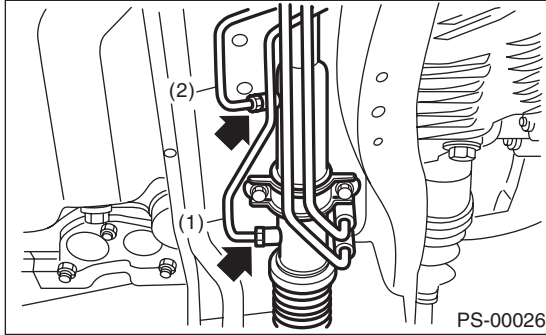

- (1) Pipe A
- (2) Pipe B

If the cruise control actuator and power steering hose clearance is less than 10 mm (0.39 in), move section (A) held in place by the clamp, or bend (B) to adjust.

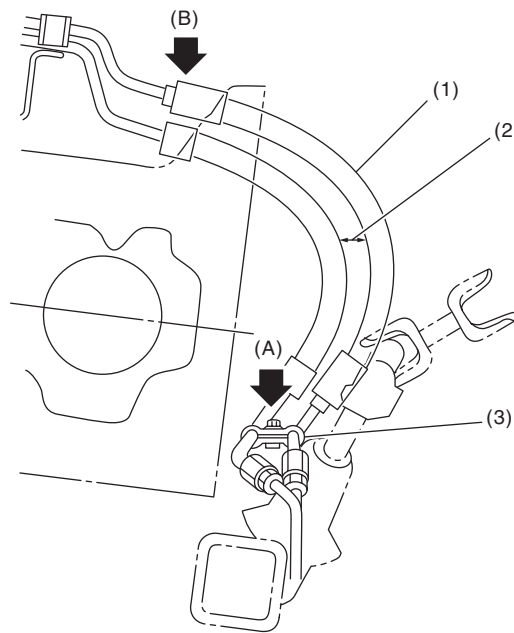

PS-00179

- (1) High-pressure hose
- (2) No interference is allowed between hoses.
- (3) Clearance between crossmember and pipe: 3 — 8 mm (0.12 — 0.31 in)

7) Install the jack-up plate.

8) Install the air intake duct, the air cleaner upper cover and the air intake boot. <Ref. to IN (H4SO)-7, INSTALLATION, Air Intake Duct.>

9) Connect the ground cable to the battery.

10) Fill with the specified fluid.

### **CAUTION:**

**Never start the engine before feeding the fluid otherwise the vane pump might be seize.**

11) Finally, check clearance between pipes or hoses as shown in the figure.

### **Clearance:**

**10 mm (0.39 in) or more**

# Pipe Assembly

POWER ASSISTED SYSTEM (POWER STEERING)

## C: INSPECTION

Check all disassembled parts for wear, damage or other problems. Repair or replace the defective parts as necessary.

Part	Inspection	Corrective action
Pipe	<ul style="list-style-type: none"> <li>• O-ring fitting surface damage</li> <li>• Nut damage</li> <li>• Pipe damage</li> </ul>	Replace with a new part.
Clamp	Loose clamps	Replace with a new part.
Hose	<ul style="list-style-type: none"> <li>• Flare surface damage</li> <li>• Flare nut damage</li> <li>• Outer surface cracks</li> <li>• Outer surface wear</li> <li>• Clip damage</li> <li>• End coupling or adapter deformation</li> </ul>	Replace with a new part.

## CAUTION:

Although the surface layer materials of rubber hoses have excellent weathering resistance, heat resistance and resistance for low temperature brittleness, they will be damaged chemically by brake fluid, battery electrolyte, engine oil and automatic transmission fluid and their service lives will be very shortened. Wipe off hoses immediately if any of these come into contact with the hoses.

Since resistances for heat and low temperature brittleness gradually declines according to long periods of exposure to hot or cold conditions, and their service lives are shortening accordingly. It is necessary to perform careful inspection frequently when the vehicle is used in hot weather areas, cold weather areas and in frequent driving conditions where a lot of steering work is required.

Particularly when there is continuous operation of the relief valve for over 5 seconds, the life of the hoses, oil pump, and fluid will be shortened due to overheating.

Trouble	Possible cause	Corrective action
Pressure hose burst	Excessive holding time of relief status	Replace. Instruct customers.
	Malfunction of the relief valve	Replace the oil pump.
	Poor cold characteristic of fluid	Replace fluid.
Disconnection of the return hose	Improper connection	Correct.
	Loosening of the clip	Retighten.
	Poor cold characteristic of fluid	Replace fluid.
Fluid slightly leaking out of hose	Wrong layout, tensioned	Replace the hose.
	Excessive play of engine due to deterioration of engine mounting rubber	Replace the parts if defective.
	Improper stop position of pitching stopper	Replace the parts if defective.
Crack on hose	Excessive holding time of relief status	Replace. Instruct customer.
	Excessive tightening torque for return hose clip	Replace. Tighten to the specified torque.
	Power steering fluid, brake fluid, engine oil, or electrolyte coming into contact with the hose surface	Replace. Be careful during service work.
	Hard steering work in a short period of time during extreme cold weather.	Replace. Instruct customers.

# Pipe Assembly

## POWER ASSISTED SYSTEM (POWER STEERING)

### NOTE:

There are conditions in which a fluid leak is diagnosed, but is not actually leaking. This is because the fluid spilt during the last maintenance was not completely wiped off. Be sure to wipe off spilt fluid thoroughly after maintenance.

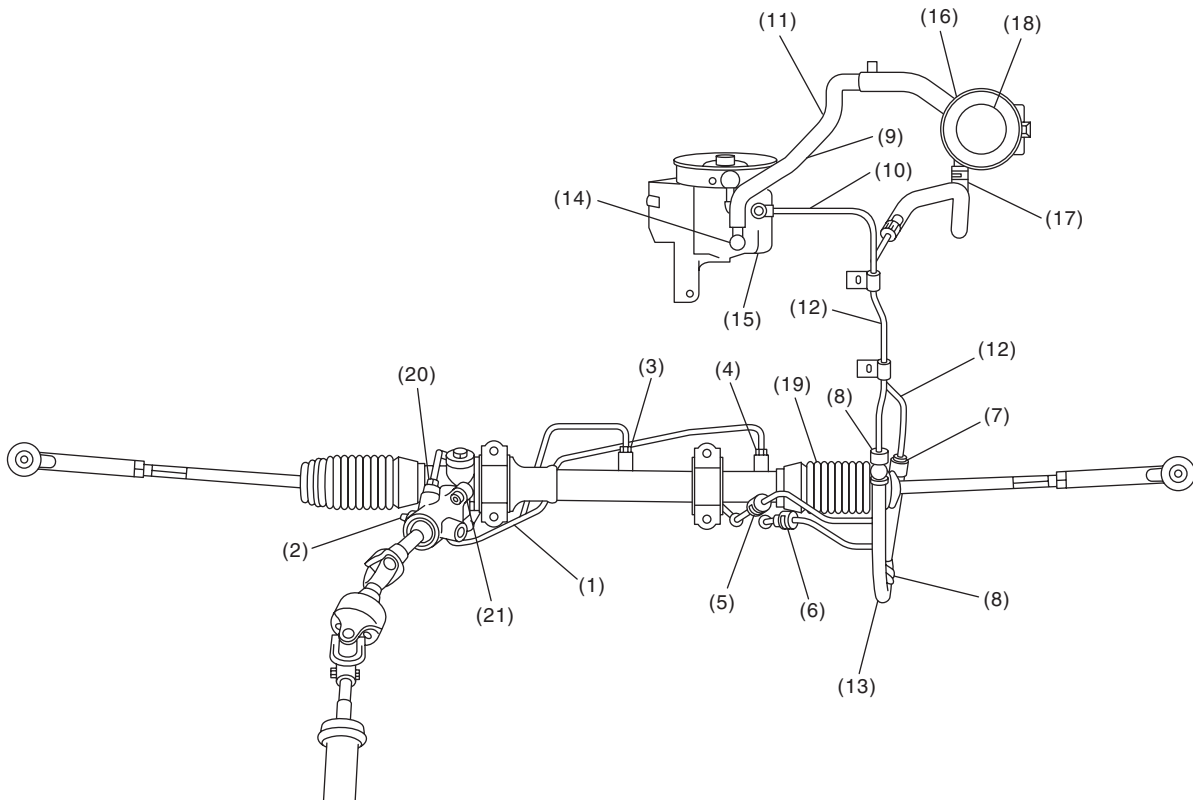

PS-00022

# Pipe Assembly

POWER ASSISTED SYSTEM (POWER STEERING)

Fluid leaking area	Possible cause	Corrective action
Leakage from the connections of pipes and hoses, numbered with (1) through (10) in the figure	Insufficient tightening of flare nuts, dirt accumulation, damage to flare or flare nut or eye bolt	Loosen and retighten. Replace if ineffective.
	Improper installation of hoses or poor clamping	Retighten or replace the clamp.
	Damaged O-ring or gasket	Replace the O-ring, gasket pipe or hose with new parts. If there is still no improvement, replace the gearbox assembly.
Leakage from hose (11), (12) and (13) in the figure	Crack or damage in hose	Replace with a new part.
	Crack or damage in hose hardware	Replace with a new part.
Leakage from surrounding of cast iron portion of oil pump, (14) and (15) in the figure	Damaged O-ring	Replace the oil pump.
	Damaged gasket	Replace the oil pump.
Leakage from reservoir (16) and (17) in the figure	Crack in the reservoir tank	Replace the reservoir tank.
Leakage from filler neck of (18)	Damaged cap packing	Replace the cap.
	Crack in root of filler neck	Replace the reservoir tank.
	Fluid level too high	Adjust the fluid level.
Leakage from power cylinder of gearbox area (19) in the figure	Damaged oil seal	Replace the oil seal.
Leakage from (20), (21) in the figure and control valve of gearbox	Damaged packing or oil seal	Replace the problem parts.
	Damage in control valve	Replace the control valve.