

VDC Hydraulic Control Module (VDCH/M)

VEHICLE DYNAMICS CONTROL (VDC)

3. VDC Hydraulic Control Module (VDCH/M)

A: REMOVAL

1. VDCH/M

- 1) Disconnect the ground cable from battery.

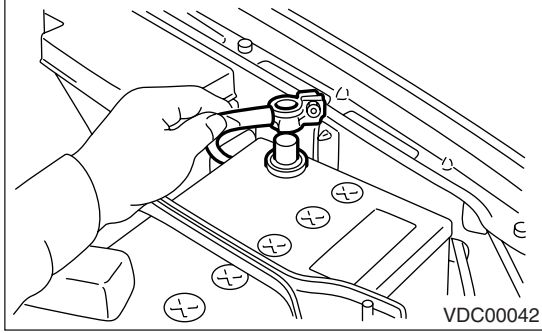

- 2) Remove the air intake duct from engine room to make it easier to remove the VDCH/M.
- 3) Disconnect the connector from the VDCH/M.

CAUTION:

Be careful to keep water and other foreign materials from coming into contact with the VDCH/M terminals.

- 4) Remove the cable clip.
- 5) Remove the brake pipes from the VDCH/M.

CAUTION:

Wrap the brake pipe in a vinyl bag so that brake fluid does not splash on the vehicle body.

- 6) Remove the ground wire of the VDCH/M.

- 7) Remove the two bolts which hold the VDCH/M, then remove the VDCH/M from the engine room.

CAUTION:

- The VDCH/M is not to be disassembled. Do not attempt to loosen the bolts and nuts.
- Do not drop or bump the VDCH/M.
- Do not turn VDCH/M upside down or place it sideways.
- Be careful to prevent foreign particles from getting into the VDCH/M.
- After installing the new VDCH/M, tighten the bracket bolts then apply rust-proofing wax (Nippeco LT or GB) to the bracket bolts.
- Do not pull on the harness when disconnecting the harness connector.

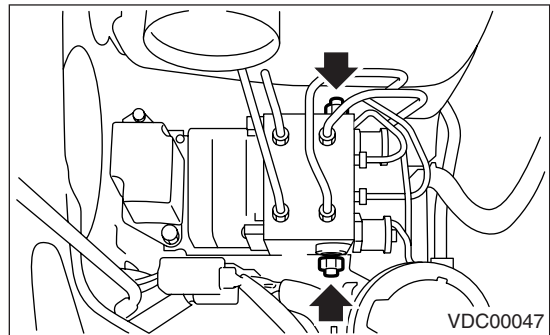

2. RELAY BOX

- 1) Disconnect the ground cable from battery.
- 2) Remove the air intake duct from engine room to make it easier to remove the relay box.
- 3) Disconnect the connector from relay box.
- 4) Remove the cable clip.
- 5) Remove the bolts which secure the relay box, and remove the relay box and connector bracket.

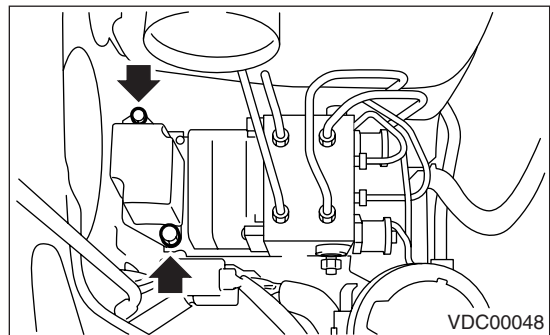

CAUTION:

Do not drop or bump the relay box.

B: INSTALLATION

1. VDCH/M

- 1) Install the VDCH/M.

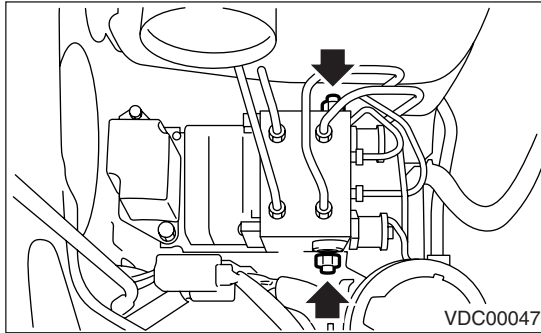

Tightening torque:

18 N·m (1.8 kgf·m, 13.0 ft-lb)

- 2) Secure the grounding wire of the VDCH/M and apply the specified grease to the ground terminals.

Specified grease:

Nippeco LT or GB

Tightening torque:

33 N·m (3.3 kgf·m, 23.9 ft-lb)

- 3) Connect brake pipes to the VDCH/M connectors.

Tightening torque:

15 N·m (1.5 kgf·m, 10.8 ft-lb)

- 4) Fasten the VDCH/M connector to the connector bracket.

CAUTION:

Match the connector to the corresponding socket.

- 5) Connect the connector to VDCH/M.

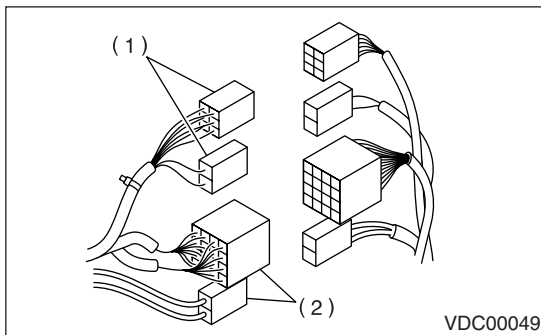

(1) Relay box connector

(2) VDCH/M connector

- 6) Install the air intake duct.
- 7) Connect the ground cable to the battery.
- 8) Bleed air from the brake system.

2. RELAY BOX

- 1) Install the relay box and connector bracket.

Tightening torque:

13 N·m (1.3 kgf·m, 9.4 ft-lb)

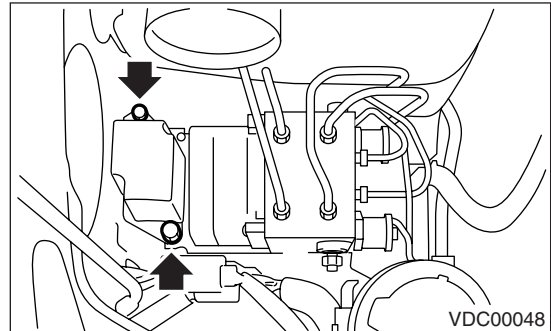

- 2) Affix the relay box connector to the connector bracket.

CAUTION:

Match the connector to the corresponding socket.

- 3) Connect the connector to the relay box.

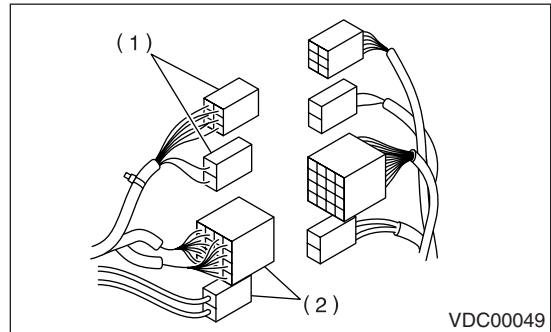

(1) Relay box connector

(2) VDCH/M connector

- 4) Install the air intake duct.
- 5) Connect the ground cable to the battery.

C: INSPECTION

- 1) Check the connection and fixture of the connector.
- 2) Inspect the valve relay and motor relay for broken wires or short circuits.
- 3) Inspect the identification of the VDCH/M.

VDC Hydraulic Control Module (VDCH/M)

VEHICLE DYNAMICS CONTROL (VDC)

Refer to "SPECIFICATION" for the identification mark. <Ref. to VDC-2, SPECIFICATION, General Description.>

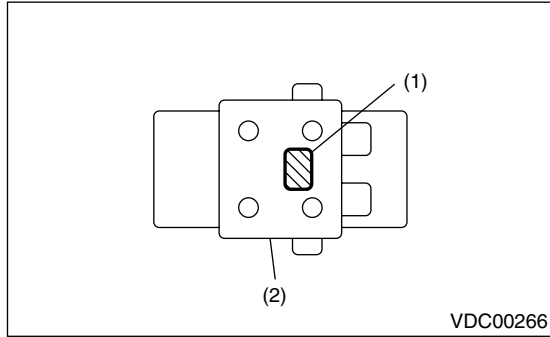

- (1) Identification mark
- (2) VDCH/M

	Condition	Terminal No.	Standard	
Valve relay	When not applying voltage	85 — 86	103±10 Ω	<p>VDC00050</p>
		30 — 87a	Less than 0.5 Ω	
		30 — 87	1 MΩ or more	
	When voltage (DC 12 V) is applied between terminal numbers 85 and 86.	30 — 87a	1 MΩ or more	
30 — 87		Less than 0.5 Ω		
Motor relay	When not applying voltage	85 — 86	80±10 Ω	<p>VDC00051</p>
		30 — 87	1 MΩ or more	
	When voltage (DC 12 V) is applied between terminal numbers 85 and 86.	30 — 87	Less than 0.5 Ω	

VDC Hydraulic Control Module (VDCH/M)

VEHICLE DYNAMICS CONTROL (VDC)

1. CHECKING THE VDC HYDRAULIC CONTROL MODULE (VDCH/M) ABS OPERATION BY PRESSURE GAUGE

- 1) Lift-up the vehicle and remove the wheel.
- 2) Disconnect the air bleeder screws from FL and FR caliper bodies.
- 3) Connect two pressure gauges to FL and FR caliper bodies.

CAUTION:

- Use a pressure gauge used exclusively for brake fluid measurement.
- Do not use a pressure gauge used previously for measurement of transmission oil pressure, as the piston seal may expand and deform.

NOTE:

Wrap sealing tape around the pressure gauge.

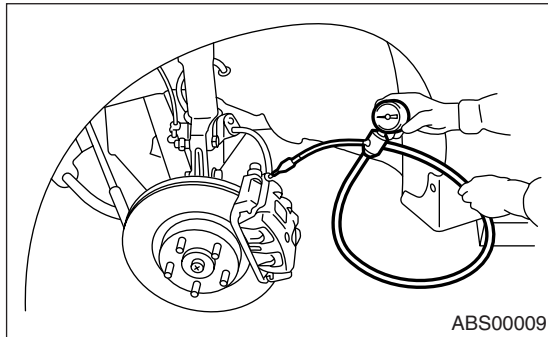

- 4) Bleed air from the pressure gauge.
- 5) Perform ABS sequence control. <Ref. to VDC-16, ABS Sequence Control.>
- 6) When the VDCH/M begins to work, first the FL side performs decompression, hold and compression, and then the FR side performs decompression, hold and compression.
- 7) Read values indicated on the pressure gauge and check whether the fluctuation of the values between decompression and compression meets the standard values. Also check whether any irregular tightness of the brake pedal can be felt.

	Front wheel	Rear wheel
Initial value	3,500 kPa (36 kgf/cm ² , 508 psi)	3,500 kPa (36 kgf/cm ² , 508 psi)
When depressurized	500 kPa (5 kgf/cm ² , 73 psi) or less	500 kPa (5 kgf/cm ² , 73 psi) or less
When pressurized	3,500 kPa (36 kgf/cm ² , 508 psi) or more	3,500 kPa (36 kgf/cm ² , 508 psi) or more

- 8) Disconnect the pressure gauges from FL and FR caliper bodies.

- 9) Install the air bleeder screws of FL and FR caliper bodies.
- 10) Remove the air bleeder screws from RL and RR caliper bodies.
- 11) Connect two pressure gauges to RL and RR caliper bodies.
- 12) Bleed air from RL and RR caliper bodies, and pressure gauge.
- 13) Perform ABS sequence control. <Ref. to VDC-16, ABS Sequence Control.>
- 14) When the VDCH/M begins to work, first the RR side performs decompression, hold and compression, and then the RL side performs decompression, hold and compression.
- 15) Read the values indicated on the pressure gauges and check if it is within specification.
- 16) After checking, remove the pressure gauges from the caliper bodies.
- 17) Install the air bleeder screws of RL and RR caliper bodies.
- 18) Bleed air from the brake line.

2. CHECKING THE VDC HYDRAULIC CONTROL MODULE (VDCH/M) ABS OPERATION WITH BRAKE TESTER

- 1) Prepare for ABS sequence control. <Ref. to VDC-16, ABS Sequence Control.>
- 2) Set the front wheels or rear wheels on the brake tester and set the select lever position to the "N" range.

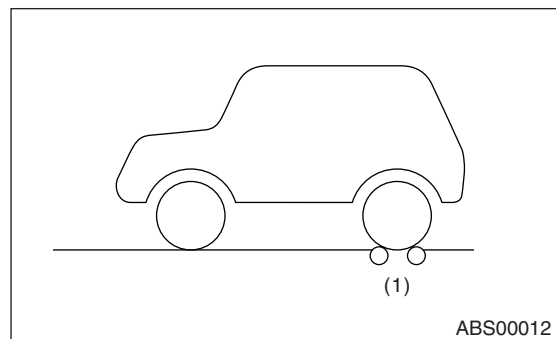
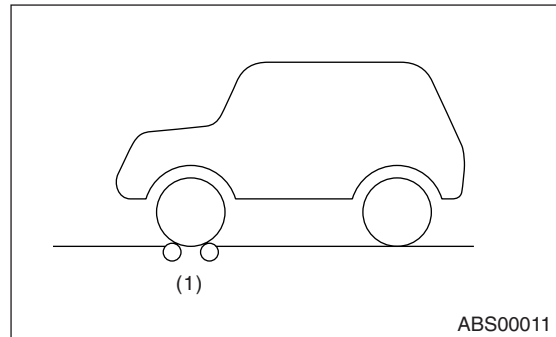

(1) Brake tester

- 3) Operate the brake tester.

VDC Hydraulic Control Module (VDCH/M)

VEHICLE DYNAMICS CONTROL (VDC)

4) Perform ABS sequence control. <Ref. to VDC-16, ABS Sequence Control.>

5) When the VDCH/M begins to work, check the following working sequence.

(1) The FL wheel performs decompression, hold and compression in sequence, and subsequently the FR wheel repeats the cycle.

(2) The RR wheel performs decompression, hold and compression in sequence, and subsequently the RL wheel repeats the cycle.

6) Read values indicated on the brake tester and check if the fluctuation of the values between decompression and compression meets specification.

	Front wheel	Rear wheel
Initial value	1,000 N (102 kgf, 224 lb)	1,000 N (102 kgf, 224 lb)
When depressurized	500 N (51 kgf, 112 lb) or less	500 N (51 kgf, 112 lb) or less
When pressurized	1,000 N (102 kgf, 224 lb) or more	1,000 N (102 kgf, 224 lb) or more

7) After checking, press the brake pedal and check whether any irregular tightness of the brake pedal can be felt.

3. CHECKING THE VDC HYDRAULIC CONTROL MODULE (VDCH/M) VDC OPERATION BY PRESSURE GAUGE

1) Lift-up the vehicle and remove the wheel.

2) Disconnect the air bleeder screws from FL and FR caliper bodies.

3) Connect two pressure gauges to FL and FR caliper bodies.

CAUTION:

- Use a pressure gauge used exclusively for brake fluid measurement.
- Do not use a pressure gauge used previously for measurement of transmission oil pressure, as the piston seal may expand and deform.

NOTE:

Wrap sealing tape around the pressure gauge.

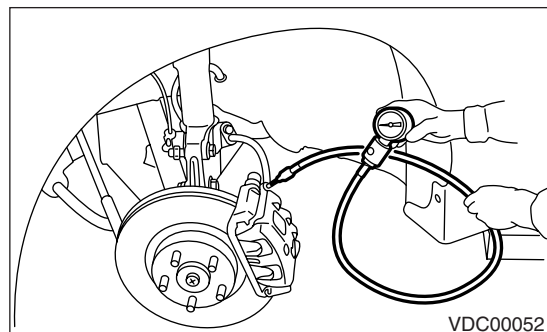

4) Bleed air from the pressure gauge.

5) Perform VDC sequence control.

<Ref. to VDC-19, VDC Sequence Control.>

6) When the VDCH/M begins to work, first the FL side performs hold, decompression, and compression, and then the FR side performs decompression, hold and compression.

7) Read values indicated on the pressure gauge and check if the fluctuation of the values between decompression and compression meets the standard values. Also check whether any irregular tightness of the brake pedal can be felt.

	Front wheel	Rear wheel
When pressurized	3,000 kPa (31 kg/cm ² , 435 psi) or more	2,000 kPa (20 kg/cm ² , 290 psi) or more
When depressurized	500 kPa (5 kg/cm ² , 73 psi) or less	500 kPa (5 kg/cm ² , 73 psi) or less

8) Disconnect the pressure gauges from FL and FR caliper bodies.

9) Connect the air bleeder screws to the FL and FR caliper bodies.

10) Remove the air bleeder screws from RL and RR caliper bodies.

11) Connect two pressure gauges to RL and RR caliper bodies.

12) Bleed air from RL and RR caliper bodies, and pressure gauge.

13) Perform VDC sequence control.

<Ref. to VDC-19, VDC Sequence Control.>

14) When the hydraulic unit begins to work, first the RR side performs hold, decompression, and compression, and then the RL side performs hold, decompression, and compression.

15) Read the values indicated on the pressure gauges and check if it is within specification.

16) After checking, remove the pressure gauges from the caliper bodies.

17) Connect the air bleeder screws to RL and RR caliper bodies.

18) Bleed air from the brake line.

4. CHECKING THE VDC HYDRAULIC CONTROL MODULE (VDCH/M) VDC OPERATION BRAKE TESTER

- 1) Prepare for the VDC sequence control.
<Ref. to VDC-19, VDC Sequence Control.>
- 2) Set the front wheels or rear wheels on the brake tester and set the select lever position to the "N" range.

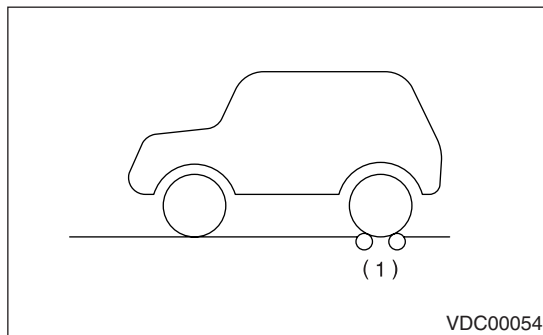
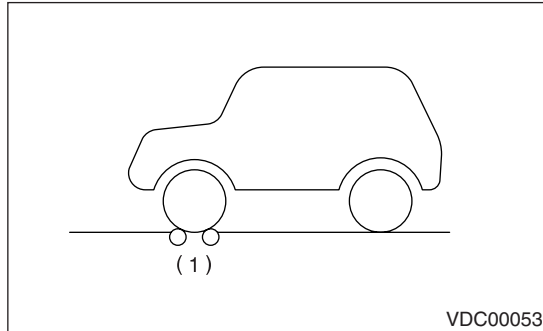

(1) Brake tester

- 3) Operate the brake tester.
- 4) Perform ABS sequence control. <Ref. to VDC-16, ABS Sequence Control.>
- 5) When the VDCH/M begins to work, check the working sequence in the following order.
 - (1) The FL wheel performs decompression, hold and compression in sequence, and subsequently the FR wheel repeats the cycle.
 - (2) The RR wheel performs decompression, hold and compression in sequence, and subsequently the RL wheel repeats the cycle.
- 6) Read values indicated on the brake tester and check if the fluctuation of the values between decompression and compression meets specification.

	Front wheel	Rear wheel
When pressurized	2,000 N (203 kgf, 447 lb) or more	1,000 N (102 kgf, 224 lb) or more
When depressurized	500 N (51 kgf, 112 lb) or less	500 N (51 kgf, 112 lb) or less

- 7) After inspection, check whether any irregular brake pedal tightness can be felt.