

Propeller Shaft

DRIVE SHAFT SYSTEM

2. Propeller Shaft

A: REMOVAL

NOTE:

- Before removing propeller shaft, wrap metal parts with a cloth or rubber material.
- In case of a EDJ type, wrap the metal parts at the rubber boot of EDJ with a cloth or rubber material before removing propeller shaft, as shown in the figure. Rubber boot may be damaged due to interference with adjacent metal parts while bending the EDJ during removal.

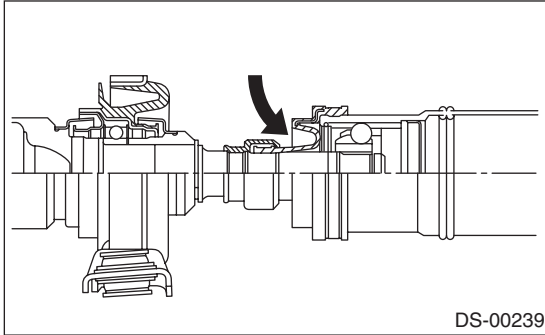

- 1) Disconnect the ground cable from the battery.
- 2) Move the select lever or the gear shift lever to "N".
- 3) Release the parking brake.
- 4) Jack-up the vehicle and support it with rigid racks.
- 5) Remove the center exhaust pipe.
Non-turbo model
<Ref. to EX (H4SO)-7, REMOVAL, Center Exhaust Pipe.>
Turbo model
<Ref. to EX(H4DOTC)-8, REMOVAL, Center Exhaust Pipe.>
- 6) Remove the rear exhaust pipe and muffler.
Non-turbo model
<Ref. to EX (H4SO)-8, REMOVAL, Rear Exhaust Pipe.> <Ref. to EX (H4SO)-9, REMOVAL, Muffler.>
Turbo model
<Ref. to EX(H4DOTC)-13, REMOVAL, Rear Exhaust Pipe.> <Ref. to EX(H4DOTC)-15, REMOVAL, Muffler.>

- 7) Remove the differential mount front cover.

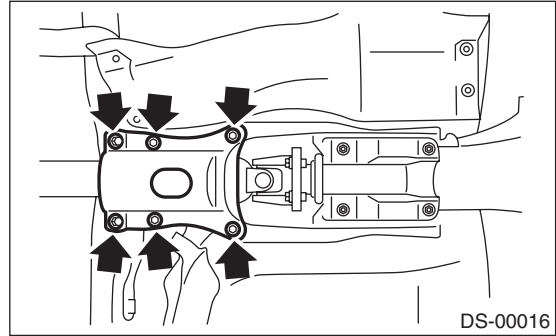

- 8) Apply alignment marks on appropriate parts before removal.

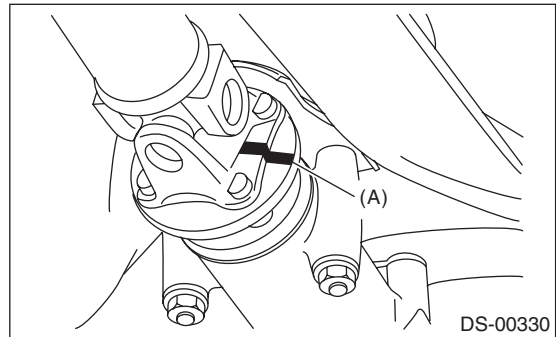

(A) Alignment mark

- 9) Remove the three bolts holding the propeller shaft to the rear differential.
- 10) Remove the remaining bolt.
- 11) Remove the two bolts which hold center bearing to the body.

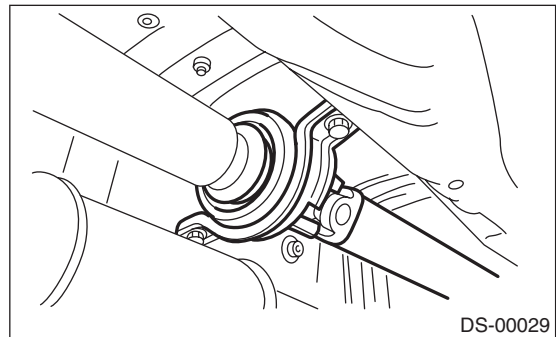

12) Remove the propeller shaft from transmission.

CAUTION:

- Be careful not to damage the oil seals and contact surface of the sleeve yoke.
- Cover the center exhaust pipe with a cloth to keep off any ATF or oil spilled from transmission when removing the propeller shaft.

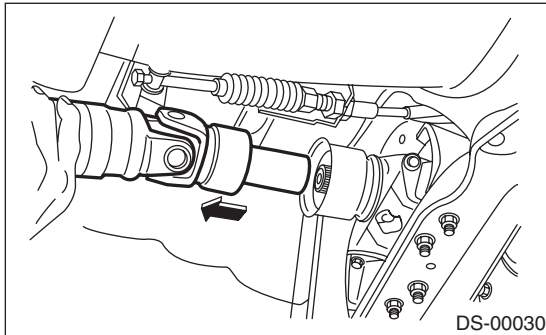

13) Install an extension cap to the transmission.

NOTE:

If an extension cap is not available, place a vinyl bag over the opening and tie with string to prevent gear oil or ATF from leaking.

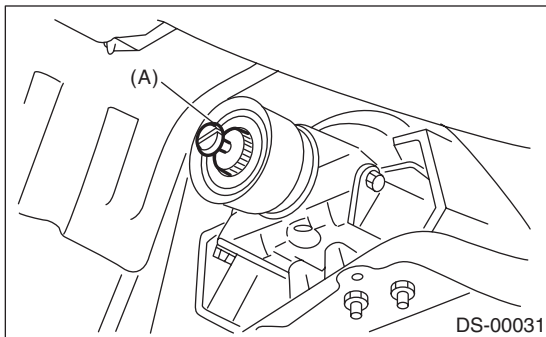

(A) Extension cap

B: INSTALLATION

1) Insert the sleeve yoke into the transmission and attach the center bearing to the body.

Tightening torque:

52 N·m (5.3 kgf·m, 38.3 ft·lb)

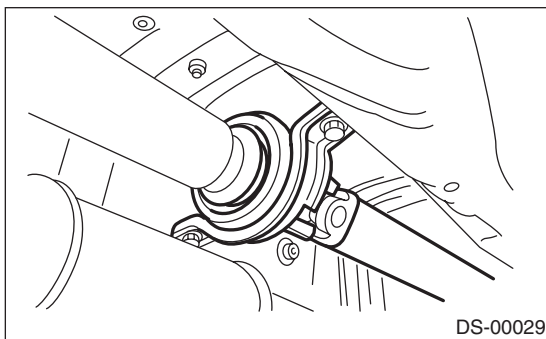

2) Align the alignment marks and connect the flange yoke and rear differential.

Tightening torque:

31 N·m (3.2 kgf·m, 23.1 ft·lb)

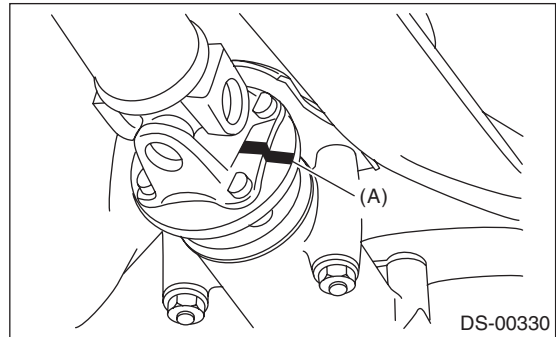

(A) Alignment mark

3) Using new bolts, install the differential mount front cover.

(1) Temporarily tighten the bolt A while pushing the cover towards the front of the vehicle.

(2) Tighten the bolts B to the specified torque.

(3) Tighten the bolts A to the specified torque.

(4) Tighten the remaining bolts to the specified torque.

Tightening torque:

90 N·m (9.2 kgf·m, 66 ft·lb)

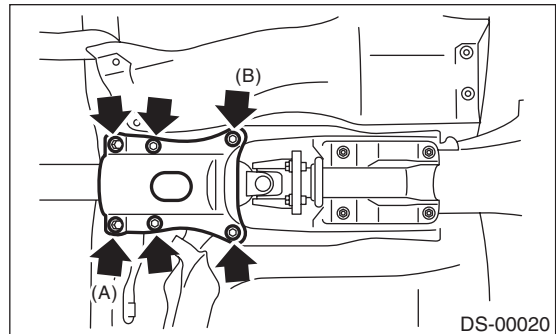

4) Install the center exhaust pipe.

Non-turbo model

<Ref. to EX (H4SO)-7, INSTALLATION, Center Exhaust Pipe.>

Turbo model

<Ref. to EX(H4DOTC)-9, INSTALLATION, Center Exhaust Pipe.>

5) Install the rear exhaust pipe and muffler.

Non-turbo model

<Ref. to EX (H4SO)-8, INSTALLATION, Rear Exhaust Pipe.> <Ref. to EX (H4SO)-9, INSTALLATION, Muffler.>

Turbo model

<Ref. to EX(H4DOTC)-14, INSTALLATION, Rear Exhaust Pipe.> <Ref. to EX(H4DOTC)-15, INSTALLATION, Muffler.>

Propeller Shaft

DRIVE SHAFT SYSTEM

C: INSPECTION

NOTE:

Do not disassemble the propeller shaft. Check the following items and replace if necessary.

- 1) Dents or cracks on the tube surface
- 2) Deformation or uneven wear on the splines
- 3) Unsmooth joint operation or abnormal noise
- 4) Center bearing free play, noise or unsmooth operation.
- 5) Uneven wear or damaged oil seal
- 6) Damaged center bearing

Check the following points with the propeller shaft installed in the vehicle.

1. JOINTS AND CONNECTIONS

- 1) Remove the center exhaust pipe.

Non-turbo model

<Ref. to EX (H4SO)-7, REMOVAL, Center Exhaust Pipe.>

Turbo model

<Ref. to EX(H4DOTC)-8, REMOVAL, Center Exhaust Pipe.>

- 2) Remove the heat shield cover. (If equipped)
- 3) Check for any looseness of the yoke flange mounting bolts which connect to the rear differential and center bearing bracket mounting bolts.

2. SPLINES AND BEARING LOCATIONS

- 1) Remove the center exhaust pipe.

Non-turbo model

<Ref. to EX (H4SO)-7, REMOVAL, Center Exhaust Pipe.>

Turbo model

<Ref. to EX(H4DOTC)-8, REMOVAL, Center Exhaust Pipe.>

- 2) Remove the rear exhaust pipe and muffler.

Non-turbo model

<Ref. to EX (H4SO)-8, REMOVAL, Rear Exhaust Pipe.> <Ref. to EX (H4SO)-9, REMOVAL, Muffler.>

Turbo model

<Ref. to EX(H4DOTC)-13, REMOVAL, Rear Exhaust Pipe.> <Ref. to EX(H4DOTC)-15, REMOVAL, Muffler.>

- 3) Remove the heat shield cover. (If equipped)

- 4) Turn the propeller shaft by hand to see if there is any excessive free play in the splines. Also move the yoke to see if there is any excessive free play at the spiders or bearings.

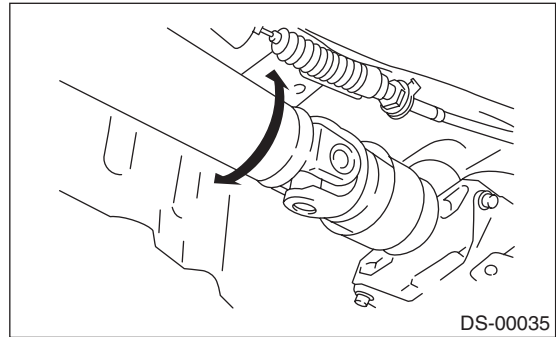

3. RUNOUT OF PROPELLER SHAFT

- 1) Remove the center exhaust pipe.

Non-turbo model

<Ref. to EX (H4SO)-7, REMOVAL, Center Exhaust Pipe.>

Turbo model

<Ref. to EX(H4DOTC)-8, REMOVAL, Center Exhaust Pipe.>

- 2) Remove the rear exhaust pipe and muffler.

Non-turbo model

<Ref. to EX (H4SO)-8, REMOVAL, Rear Exhaust Pipe.> <Ref. to EX (H4SO)-9, REMOVAL, Muffler.>

Turbo model

<Ref. to EX(H4DOTC)-13, REMOVAL, Rear Exhaust Pipe.> <Ref. to EX(H4DOTC)-15, REMOVAL, Muffler.>

- 3) Remove the heat shield cover. (If equipped)

4) Set the dial gauge with its indicator stem at the center of the propeller shaft tube.

5) Turn the propeller shaft slowly by hands to check for runout of the propeller shaft.

Runout:

Limit:

0.6 mm (0.024 in)

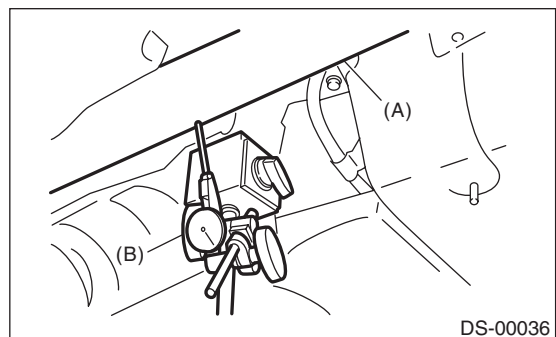

(A) Propeller shaft

(B) Dial gauge

4. CENTER BEARING FREE PLAY

1) Remove the front and center exhaust pipes.

Non-turbo model

<Ref. to EX (H4SO)-4, REMOVAL, Front Exhaust Pipe.> <Ref. to EX (H4SO)-7, REMOVAL, Center Exhaust Pipe.>

Turbo model

<Ref. to EX(H4DOTC)-6, REMOVAL, Front Exhaust Pipe.> <Ref. to EX(H4DOTC)-8, REMOVAL, Center Exhaust Pipe.>

2) Remove the rear exhaust pipe and muffler.

Non-turbo model

<Ref. to EX (H4SO)-8, REMOVAL, Rear Exhaust Pipe.> <Ref. to EX (H4SO)-9, REMOVAL, Muffler.>

Turbo model

<Ref. to EX(H4DOTC)-13, REMOVAL, Rear Exhaust Pipe.> <Ref. to EX(H4DOTC)-15, REMOVAL, Muffler.>

3) Remove the heat shield cover. (If equipped)

4) Move the propeller shaft near the center bearing up, down, left, right by hand, to check for any abnormal free play of the bearings.

