

Rear Drive Shaft

DRIVE SHAFT SYSTEM

6. Rear Drive Shaft

A: REMOVAL

- 1) Disconnect the ground cable from the battery.
- 2) Lift-up the vehicle, and then remove the rear wheels.
- 3) Lift the crimped section of the axle nut.

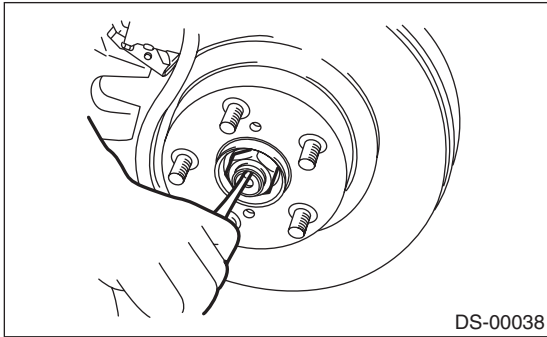

- 4) While applying the parking brake, remove the axle nut using a socket wrench.

CAUTION:

Remove the axle nut while there is no load being applied to the axle. Failure to do so may damage the wheel bearings.

- 5) Remove the rear stabilizer link.

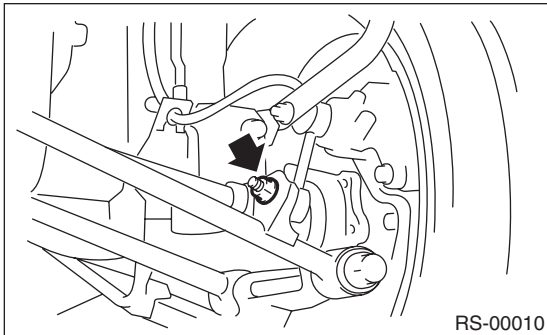

- 6) Remove the bolts which secure the trailing link to the housing.

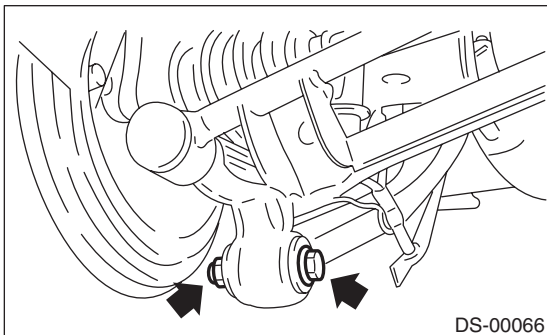

- 7) Remove the bolts which secure the front and rear lateral link to the housing.

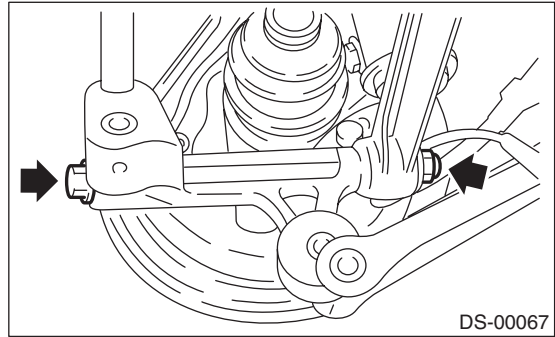

- 8) Remove the rear ABS wheel speed sensor from the back plate.

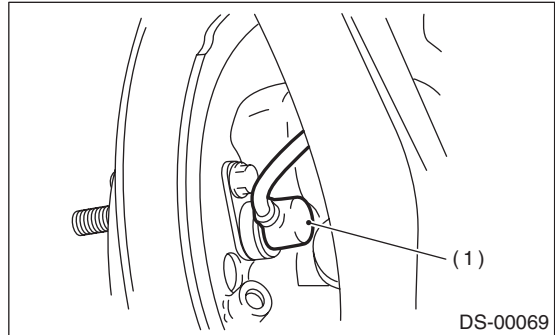

(1) ABS wheel speed sensor

- 9) Remove the rear drive shaft from the rear axle. If it is hard to remove, use ST1 and ST2 to remove the brake disc rotor.

ST1 926470000 AXLE SHAFT PULLER
ST2 927140000 AXLE SHAFT PULLER PLATE

CAUTION:

- Do not hammer the drive shaft when removing it.
- Do not damage the oil seal and tone wheel.

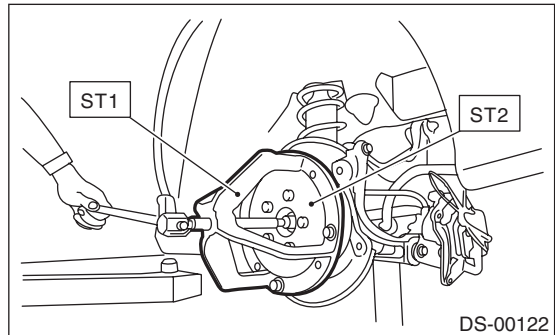

10) Remove the rear drive shaft from the rear differential by using the ST.

ST 28099PA100 DRIVE SHAFT REMOVER

CAUTION:

As shown in the figure, set the ST to the bolt (A) without damaging the side bearing retainer.

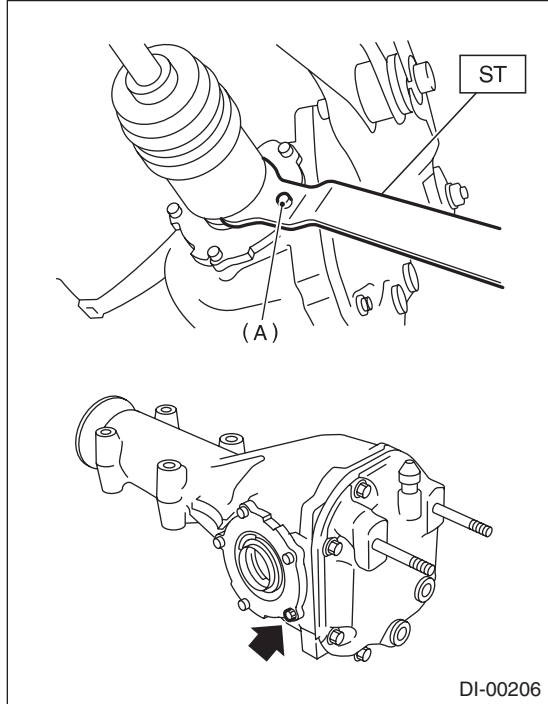

(A) Bolt

B: INSTALLATION

- 1) Insert the rear drive shaft into the rear axle.
 - 2) Tighten the axle nut temporarily.
 - 3) Using the ST, install the rear drive shaft to the rear differential while protecting the oil seal.
- ST 28099PA090 OIL SEAL PROTECTOR

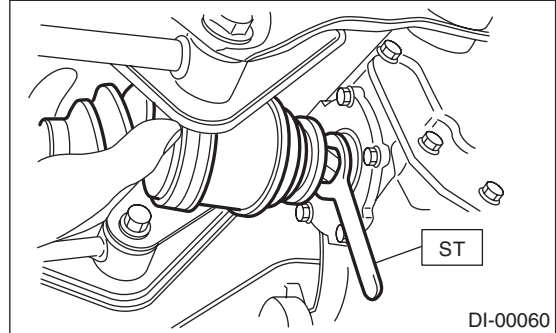

- 4) Using new self-locking nuts, temporarily tighten the front and rear lateral links to the housing.

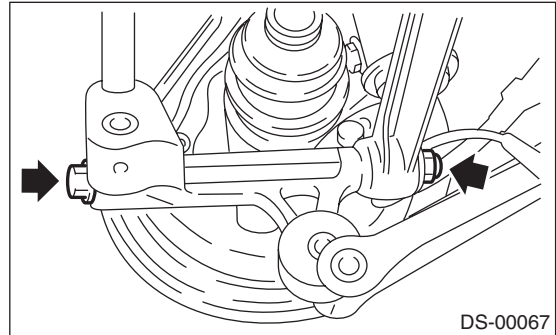

- 5) Using new self-locking nuts, temporarily attach the trailing link to the housing.

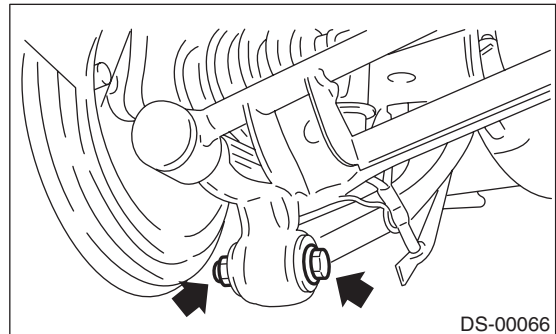

Rear Drive Shaft

DRIVE SHAFT SYSTEM

6) Install the stabilizer link.

Tightening torque:

45 N·m (4.6 kgf·m, 33 ft·lb)

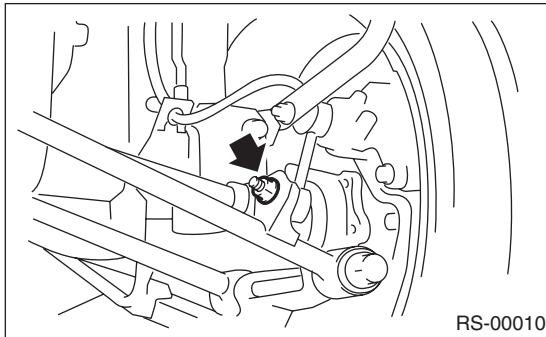

7) Install the ABS wheel speed sensor.

Tightening torque:

32 N·m (3.3 kgf·m, 24 ft·lb)

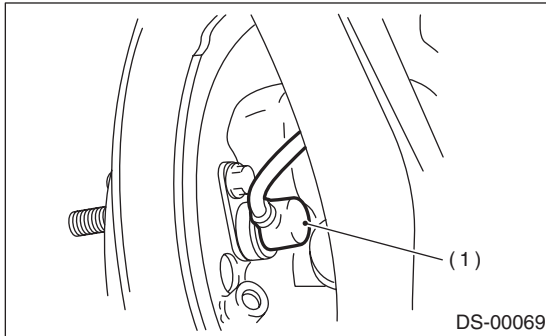

(1) ABS wheel speed sensor

8) Using ST1 and ST2, pull the rear drive shaft to the required location.

ST1 922431000 AXLE SHAFT INSTALLER

ST2 927390000 ADAPTER

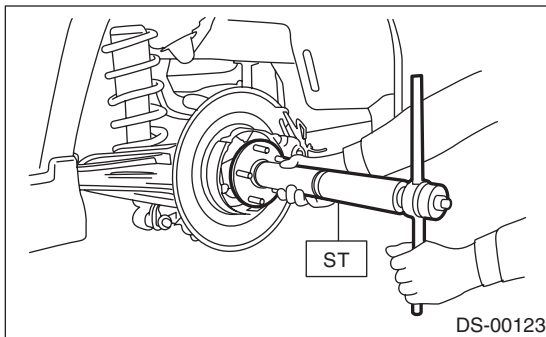

9) While applying the parking brake pedal, tighten the new axle nut to the specified torque.

Tightening torque:

190 N·m (19.4 kgf·m, 140 ft·lb)

CAUTION:

Be sure to tighten the axle nut to specified torque. Do not overtighten it as this may damage the wheel bearing.

10) After tightening the axle nut, lock it securely.

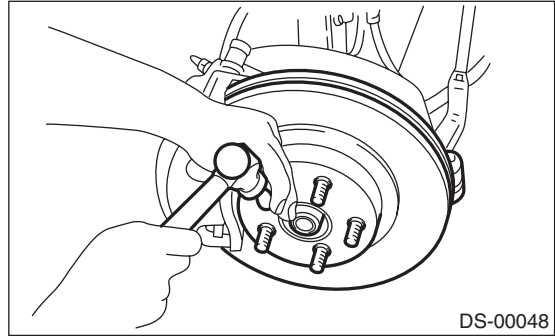

11) Install the wheel.

Tightening torque:

100 N·m (10.2 kgf·m, 73.8 ft·lb)

12) Make the tires completely touch the ground.

CAUTION:

Always tighten bushings with wheels in full contact with the ground and the vehicle at curb weight.

13) Tighten the rear housing assembly and lateral link assembly installation bolts.

Tightening torque:

140 N·m (14.3 kgf·m, 103 ft·lb)

14) Tighten the rear housing assembly and trailing link assembly installation bolts.

Tightening torque:

90 N·m (9.2 kgf·m, 66 ft·lb)

C: DISASSEMBLY

- 1) Straighten the bent claw at the larger end of the DOJ boot.
- 2) Loosen the band by means of a flat tip screwdriver or pliers, being careful not to damage the boot.

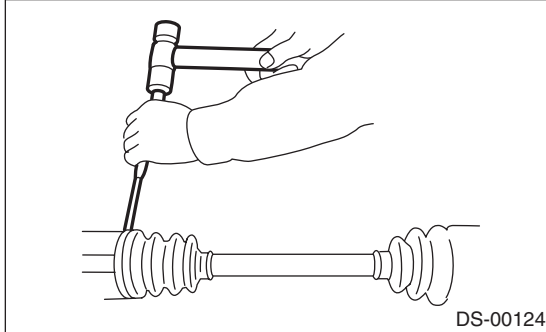

- 3) Remove the boot band on the small end of DOJ boot in the same manner.
- 4) Remove the larger end of DOJ boot from DOJ outer race.
- 5) Pry and remove the circlip at the neck of DOJ outer race with a screwdriver.

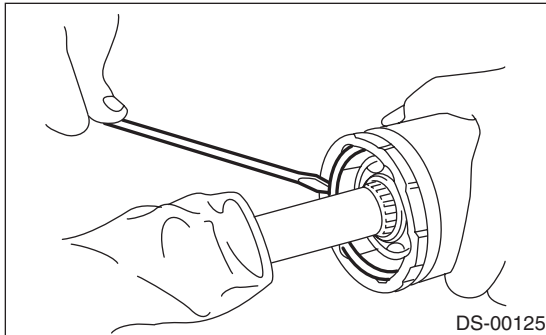

- 6) Take out the DOJ outer race from the shaft assembly.
- 7) Wipe off the grease and take out the ball bearings.

CAUTION:

- **The grease is a special grease (grease for constant velocity joints). Do not mix with other greases.**

- **Disassemble while being careful not to lose ball bearings (6 pcs).**

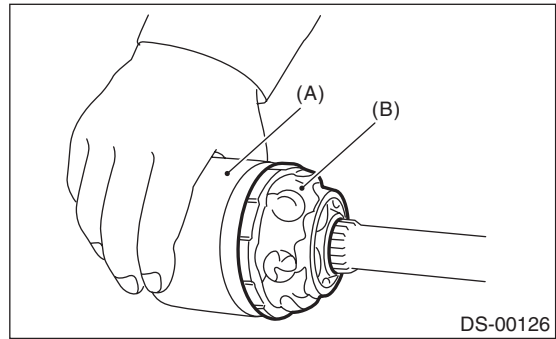

- (A) Outer race
- (B) Grease

- 8) To remove the cage from the inner race, turn the cage by a half pitch to the track groove of the inner race and move the cage.
- 9) Using pliers, remove the snap ring fixing the inner race to the shaft.
- 10) Take out the DOJ inner race.
- 11) Take off the DOJ cage from shaft and remove the DOJ boot.
- 12) Wrap vinyl tape around the spline part of shaft.
- 13) Remove the EBJ boot using the same procedures as for the DOJ boot.

NOTE:

The EBJ is a non-disassembly part, so the axle disassembly stops here.

Rear Drive Shaft

DRIVE SHAFT SYSTEM

D: ASSEMBLY

NOTE:

Use specified grease.

Grease:

EBJ side

NTG2218-M (Part No. 28395AG010)

DOJ side:

NKG205 (Part No. 28495AG000)

- 1) Install the EBJ boot to the specified position, and fill it with 60 to 70 g (2.12 to 2.47 oz) of specified grease.
- 2) Place the DOJ boot at the center of shaft.
- 3) Wrap vinyl tape around the spline part of shaft.
- 4) Insert the DOJ cage onto shaft.

CAUTION:

The cage has a set orientation. Insert the cage with the cutout portion facing the shaft side.

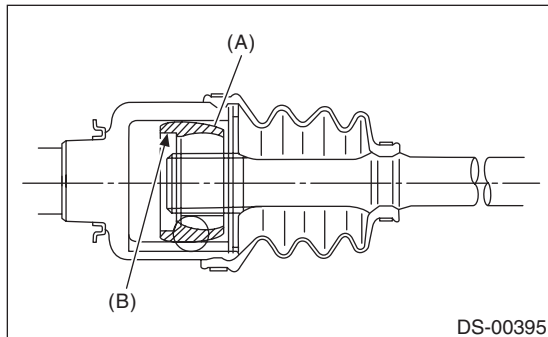

- (A) Cage
- (B) Cutout portion

- 5) Install the DOJ inner race on shaft and fix the snap ring in place with pliers.

CAUTION:

Confirm that the snap ring is completely fitted in the shaft groove.

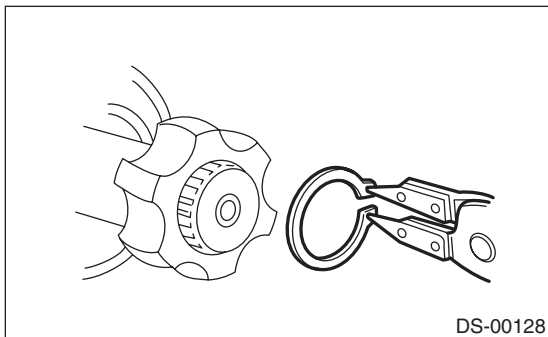

- 6) Install the removed cage, to the inner race fixed onto the shaft.

NOTE:

Fit the cage with the protruding section aligned with the track on the inner race, and turn by a half pitch.

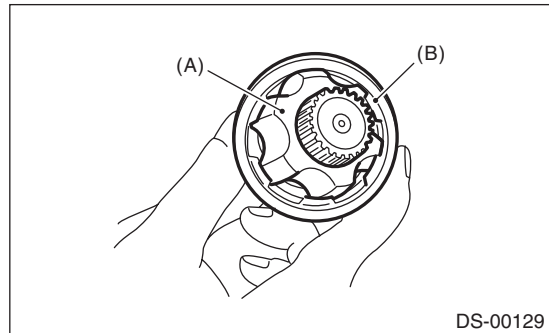

- (A) Inner race
- (B) Cage

- 7) Fill 80 to 90 g (2.82 to 3.17 oz) of specified grease into the inner side of the DOJ outer race.
- 8) Apply a thin coat of specified grease to the cage pocket and six ball bearings.
- 9) Insert the six ball bearings into the cage pocket.
- 10) Align the outer race track and ball positions, and place the shaft, inner race, cage and ball bearings in the original positions, then fix outer race in place.

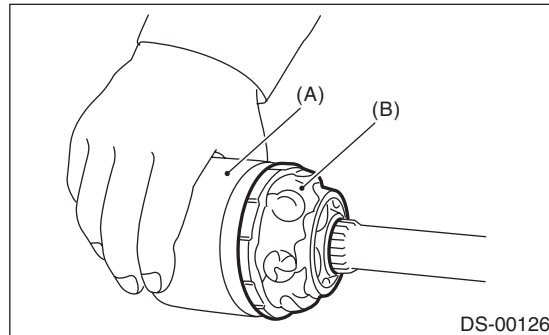

- (A) Outer race
- (B) Grease

11) Install the circlip in the groove on the DOJ outer race.

CAUTION:

- Make sure that the balls, cage and inner race are firmly fitted in the outer race of the DOJ.
- Take care not to place the matching position of the circlip in the ball groove of outer race.
- Pull the shaft lightly to make sure that the circlip is completely fitted in the groove.

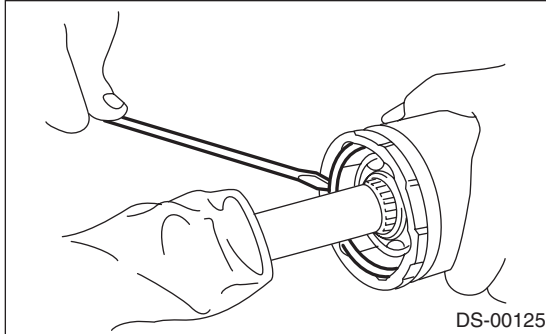

12) Apply an even coat of the specified grease [20 to 30 g (0.71 to 1.06 oz)] to the entire inner surface of boot. Also apply grease to the shaft.

13) Install the DOJ boot taking care not to twist it.

NOTE:

- The inside of the larger end of DOJ boot and the boot groove is to be cleaned so as to be free from grease and other foreign substances.
- When installing the DOJ boot, position the outer race of DOJ at center of the stroke.

14) Put a new band through the clip and wind twice in the band groove of the boot.

15) Pinch the end of band with pliers. Hold the clip and tighten securely.

CAUTION:

When tightening the boot, exercise care so that the air within the boot is appropriate.

16) Tighten the band using the ST.

ST 925091000 BAND TIGHTENING TOOL

CAUTION:

Tighten the band until it cannot be moved by hand.

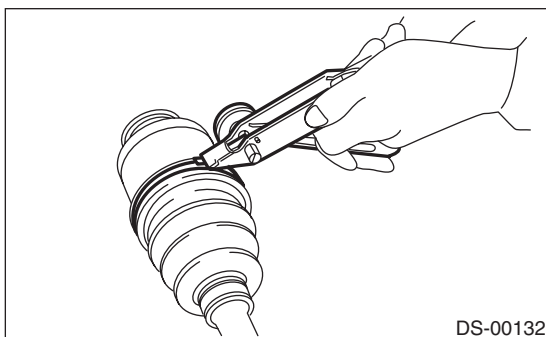

17) Tap the clip with the punch provided at the end of the ST.

ST 925091000 BAND TIGHTENING TOOL

CAUTION:

Tap to an extent that the boot underneath is not damaged.

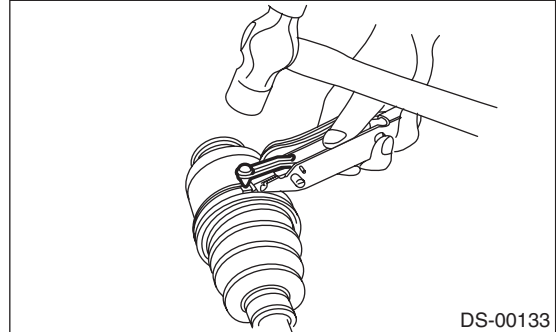

18) Cut off the band with an allowance of about 10 mm (0.39 in) left from the clip and bend this allowance over the clip.

CAUTION:

Make sure that the end of the band is in close contact with clip.

19) Install EBJ boot in the same manner.

20) Extend and retract the DOJ repeatedly to provide an equal coating of grease.

E: INSPECTION

Check the removed parts for damage, wear, corrosion etc. Repair or replace if defective.

1) DOJ (Double Offset Joint)

Check for seizure, corrosion, damage, wear and excessive play.

2) Shaft

Check for excessive bending, twisting, damage and wear.

3) EBJ

Check for seizure, corrosion, damage and excessive play.

4) Boot

Check for wear, warping, breakage and scratches.

5) Grease

Check for discoloration and fluidity.