

### 5. Rear Strut

#### A: REMOVAL

- 1) Remove the strut cap of the quarter trim.
- 2) Loosen the rear wheel nuts.
- 3) Lift-up the vehicle, and then remove the rear wheels.
- 4) Remove the brake hose clip and remove the brake hose from rear strut.

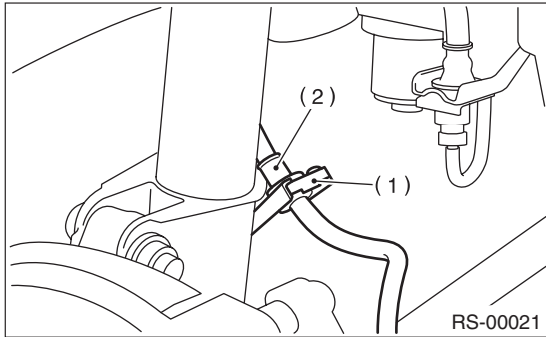

- (1) Brake hose clip
- (2) Brake hose

- 5) Remove the bolts which secure the rear strut to the housing.

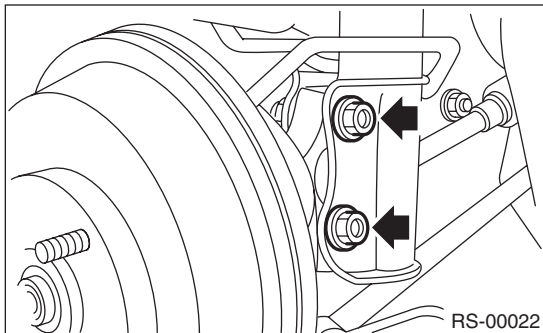

#### CAUTION:

**Do not apply excessive tension to the brake hose and ABS wheel speed sensor harness.**

- 6) Remove the nuts which secure the strut mount to the vehicle body.

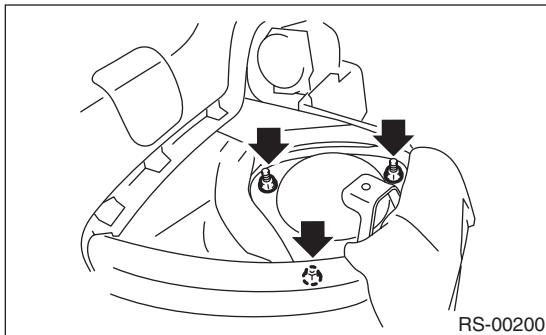

#### B: INSTALLATION

- 1) Using new self-locking nuts, and attach the strut mount to the body.

##### *Tightening torque:*

**20 N·m (2.0 kgf-m, 14.5 ft-lb)**

- 2) Using new self-locking nuts, and attach the rear strut to housing.

##### *Tightening torque:*

**200 N·m (20.4 kgf-m, 148 ft-lb)**

- 3) Attach the brake hose to lower side of the strut, then insert brake hose clip.
- 4) Lower the vehicle and tighten wheel nut.

##### *Tightening torque:*

**90 N·m (9.2 kgf-m, 66 ft-lb)**

- 5) Attach the strut cap to the rear quarter trim.
- 6) Inspect the wheel alignment and adjust if necessary.

#### C: DISASSEMBLY

Refer to the Front Struts for the procedures to disassemble the rear strut. <Ref. to FS-18, DISASSEMBLY, Front Strut.>

#### D: ASSEMBLY

Refer to Front Strut for assembly procedures. <Ref. to FS-19, ASSEMBLY, Front Strut.>

#### E: INSPECTION

Refer to Front Strut for inspection procedures. <Ref. to FS-20, INSPECTION, Front Strut.>

#### F: DISPOSAL

Refer to Front Strut for disposal procedures. <Ref. to FS-20, DISPOSAL, Front Strut.>