

Diagnostics for Engine Starting Failure

ENGINE (DIAGNOSTICS)

17. Diagnostics for Engine Starting Failure

A: PROCEDURE

1. Check for fuel amount.
↓
2. Inspection of starter motor circuit. <Ref. to EN(H4DOTC)(diag)-59, STARTER MOTOR CIRCUIT, Diagnostics for Engine Starting Failure.>
↓
3. Inspection of ECM power supply and ground line. <Ref. to EN(H4DOTC)(diag)-62, CHECK POWER SUPPLY AND GROUND LINE OF ENGINE CONTROL MODULE (ECM), Diagnostics for Engine Starting Failure.>
↓
4. Inspection of ignition control system. <Ref. to EN(H4DOTC)(diag)-64, IGNITION CONTROL SYSTEM, Diagnostics for Engine Starting Failure.>
↓
5. Inspection of fuel pump circuit. <Ref. to EN(H4DOTC)(diag)-67, FUEL PUMP CIRCUIT, Diagnostics for Engine Starting Failure.>
↓
6. Inspection of fuel injector circuit. <Ref. to EN(H4DOTC)(diag)-68, FUEL INJECTOR CIRCUIT, Diagnostics for Engine Starting Failure.>

B: STARTER MOTOR CIRCUIT

CAUTION:

After repairing or replacing the defective part, perform the Clear Memory Mode <Ref. to EN(H4DOTC)(diag)-50, OPERATION, Clear Memory Mode.> and Inspection Mode <Ref. to EN(H4DOTC)(diag)-38, PROCEDURE, Inspection Mode.>

WIRING DIAGRAM:

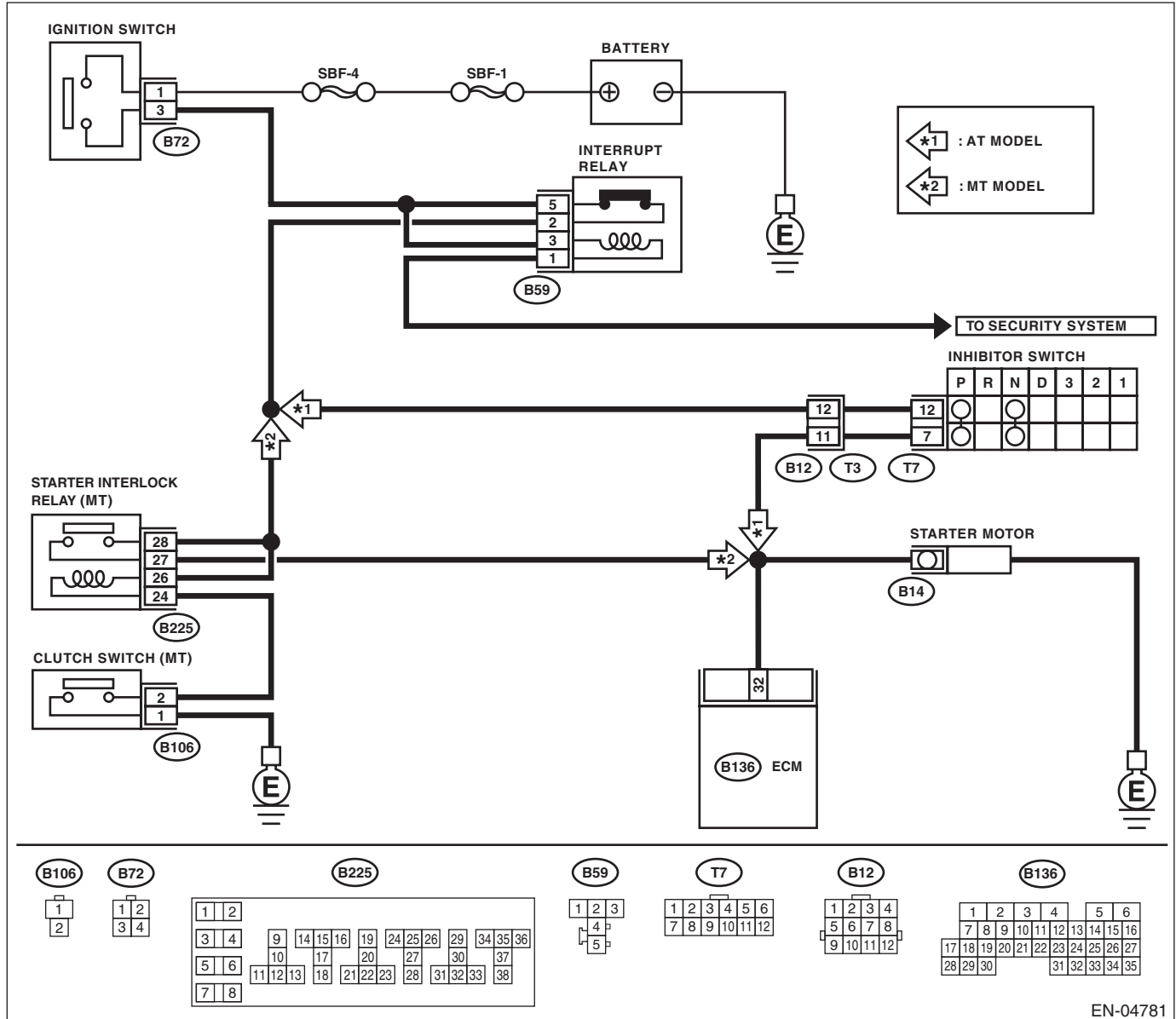

EN-04781

Diagnostics for Engine Starting Failure

ENGINE (DIAGNOSTICS)

Step	Check	Yes	No	
1	CHECK BATTERY. Check the battery voltage.	Is the voltage 12 V or more?	Go to step 2.	Charge or replace the battery.
2	CHECK OPERATION OF STARTER MOTOR.	Does the starter motor operate?	Go to step 3.	Go to step 4.
3	CHECK DTC.	Is DTC displayed? <Ref. to EN(H4DOTC)(diag)-37, OPERATION, Read Diagnostic Trouble Code (DTC).>	Check the appropriate DTC using the List of Diagnostic Trouble Code (DTC). <Ref. to EN(H4DOTC)(diag)-70, List of Diagnostic Trouble Code (DTC).>	Repair poor contact in ECM connector.
4	CHECK INPUT SIGNAL FOR STARTER MOTOR. 1) Turn the ignition switch to OFF. 2) Disconnect the connector from starter motor. 3) Turn the ignition switch to ST. 4) Measure the power supply voltage between starter motor connector terminal and engine ground. Connector & terminal (B14) No. 1 (+) — Engine ground (-): NOTE: • For AT model, place the select lever in “P” or “N” range. • For MT model, depress the clutch pedal.	Is the voltage 10 V or more?	Check the starter motor. <Ref. to SC (H4SO)-6, Starter.>	Go to step 5.
5	CHECK HARNESS BETWEEN BATTERY AND IGNITION SWITCH CONNECTOR. 1) Disconnect the connector from ignition switch. 2) Measure the power supply voltage between ignition switch connector and chassis ground. Connector & terminal (B72) No. 1 (+) — Chassis ground (-):	Is the voltage 10 V or more?	Go to step 6.	Repair the open circuit of harness between ignition switch and battery, and check fuse SBF No. 4 and SBF No. 1.
6	CHECK IGNITION SWITCH. 1) Disconnect the connector from ignition switch. 2) Measure the resistance between ignition switch terminals after turning the ignition switch to ST. Terminals No. 1 — No. 3:	Is the resistance less than 5 Ω?	Go to step 7.	Replace the ignition switch.
7	CHECK TRANSMISSION TYPE. Check the type of the transmission.	Is the transmission type AT?	Go to step 8.	Go to step 12.
8	CHECK INHIBITOR SWITCH INPUT VOLTAGE. 1) Turn the ignition switch to OFF. 2) Disconnect the connector from inhibitor switch. 3) Connect the connector to the ignition switch. 4) Measure the input voltage between inhibitor switch connector terminal and engine ground while turning the ignition switch to ST. Connector & terminal (B12) No. 12 (+) — Engine ground (-):	Is the voltage 10 V or more?	Go to step 9.	Repair open or ground short circuit of harness between inhibitor switch and ignition switch. NOTE: Check security system (if equipped). <Ref. to SL-21, Security System.>

Diagnostics for Engine Starting Failure

ENGINE (DIAGNOSTICS)

Step	Check	Yes	No
9 CHECK INHIBITOR SWITCH. 1) Place the select lever in "P" or "N" range. 2) Measure the resistance between inhibitor switch terminals. <i>Connector & terminal</i> <i>(T3) No. 11 — No. 12:</i>	Is the resistance less than 1 Ω ?	Go to step 10.	Replace the inhibitor switch. <Ref. to 4AT-47, Inhibitor Switch.>
10 CHECK INPUT VOLTAGE OF STARTER INTERLOCK RELAY. 1) Turn the ignition switch to OFF. 2) Disconnect the connector from starter interlock relay. 3) Connect the connector to ignition switch. 4) Measure the input voltage between starter interlock relay connector and chassis ground after turning the ignition switch to ST. <i>Connector & terminal</i> <i>(B225) No. 26 (+) — Chassis ground (-):</i> <i>(B225) No. 28 (+) — Chassis ground (-):</i>	Is the voltage 10 V or more?	Go to step 11.	Repair open or short circuit to ground in harness between starter interlock relay and ignition switch. NOTE: Check security system (if equipped). <Ref. to SL-21, Security System.>
11 CHECK STARTER INTERLOCK RELAY. 1) Connect the battery to starter interlock relay terminals No. 26 and No. 24. 2) Measure the resistance between starter interlock relay terminals. <i>Terminals</i> <i>No. 27 — No. 28:</i>	Is the resistance less than 1 Ω ?	Go to step 12.	Replace the starter interlock relay.
12 CHECK GROUND CIRCUIT OF CLUTCH SWITCH. 1) Disconnect the connector from clutch switch. 2) Measure the resistance between the clutch switch connector and chassis ground. <i>Connector & terminal</i> <i>(B106) No. 1 — Chassis ground:</i>	Is the resistance less than 1 Ω ?	Go to step 13.	Repair the open circuit of ground cable.
13 CHECK CLUTCH SWITCH. Measure the resistance between clutch switch terminals while depressing the clutch pedal. <i>Terminals</i> <i>No. 1 — No. 2:</i>	Is the resistance less than 1 Ω ?	Go to step 14.	Replace the clutch switch. <Ref. to CL-28, Clutch Switch.>
14 CHECK CLUTCH SWITCH CIRCUIT. 1) Connect the connector to the clutch switch. 2) Measure the resistance between starter interlock relay connector and chassis ground while depressing the clutch pedal. <i>Connector & terminal</i> <i>(B225) No. 24 — Chassis ground:</i>	Is the resistance less than 1 Ω ?	Repair the ground short of the harness between starter interlock relay and starter motor.	Repair the open circuit in harness between starter interlock relay and clutch switch.

Diagnostics for Engine Starting Failure

ENGINE (DIAGNOSTICS)

C: CHECK POWER SUPPLY AND GROUND LINE OF ENGINE CONTROL MODULE (ECM)

CAUTION:

After repairing or replacing the defective part, perform the Clear Memory Mode <Ref. to EN(H4DOTC)(diag)-50, OPERATION, Clear Memory Mode.> and Inspection Mode <Ref. to EN(H4DOTC)(diag)-38, PROCEDURE, Inspection Mode.>

WIRING DIAGRAM:

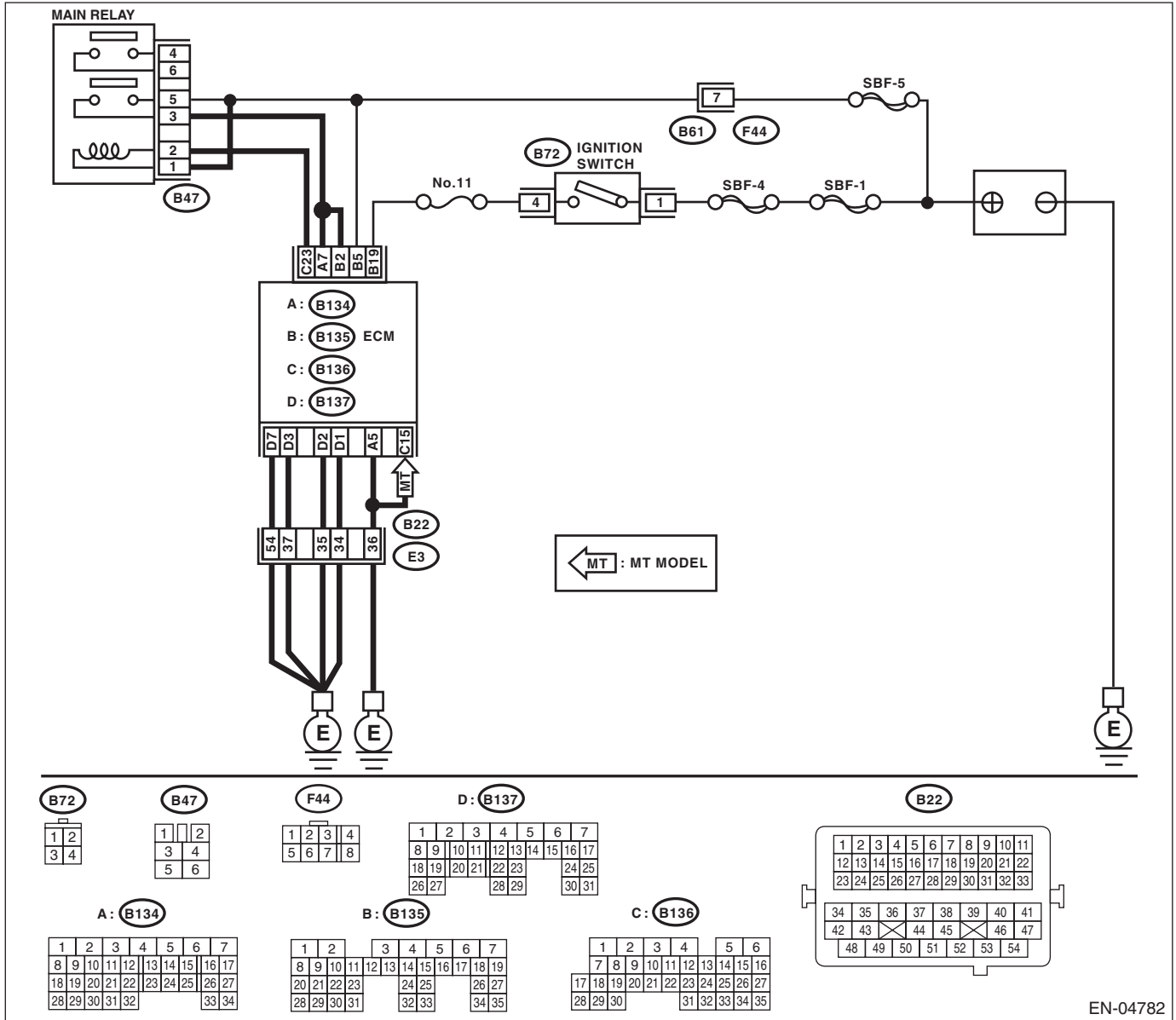

Diagnostics for Engine Starting Failure

ENGINE (DIAGNOSTICS)

Step	Check	Yes	No
1 CHECK MAIN RELAY. 1) Turn the ignition switch to OFF. 2) Remove the main relay. 3) Connect the battery to main relay terminals No. 1 and No. 2. 4) Measure the resistance between main relay terminals. <i>Terminals</i> No. 3 — No. 5: No. 4 — No. 6:	Is the resistance less than 10 Ω ?	Go to step 2.	Replace the main relay.
2 CHECK GROUND CIRCUIT FOR ECM. 1) Disconnect the connectors from ECM. 2) Measure the resistance of harness between ECM and chassis ground. <i>Connector & terminal</i> (B134) No. 5 — Chassis ground: (B136) No. 15 — Chassis ground: (B137) No. 1 — Chassis ground: (B137) No. 2 — Chassis ground: (B137) No. 3 — Chassis ground: (B137) No. 7 — Chassis ground:	Is the resistance less than 5 Ω ?	Go to step 3.	Repair the open circuit of harness between ECM connector and engine grounding terminal.
3 CHECK INPUT VOLTAGE OF ECM. Measure the voltage between ECM connector and chassis ground. <i>Connector & terminal</i> (B135) No. 5 (+) — Chassis ground (-): (B135) No. 19 (+) — Chassis ground (-):	Is the voltage 10 V or more?	Go to step 4.	Repair the open or ground short circuit of power supply circuit.
4 CHECK INPUT VOLTAGE OF MAIN RELAY. Measure the voltage between main relay connector and chassis ground. <i>Connector & terminal</i> (B47) No. 1 (+) — Chassis ground (-): (B47) No. 5 (+) — Chassis ground (-): (B47) No. 6 (+) — Chassis ground (-):	Is the voltage 10 V or more?	Go to step 5.	Repair the open or ground short circuit of harness of power supply circuit.
5 CHECK INPUT VOLTAGE OF ECM. 1) Connect the main relay connector. 2) Turn the ignition switch to ON. 3) Measure the voltage between ECM connector and chassis ground. <i>Connector & terminal</i> (B134) No. 7 (+) — Chassis ground (-): (B135) No. 2 (+) — Chassis ground (-): (B136) No. 23 (+) — Chassis ground (-):	Is the voltage 10 V or more?	Check ignition control system. <Ref. to EN(H4DOTC)(diag)-64, IGNITION CONTROL SYSTEM, Diagnostics for Engine Starting Failure.>	Repair the open or ground short circuit of harness between ECM connector and main relay connector.

Diagnostics for Engine Starting Failure

ENGINE (DIAGNOSTICS)

D: IGNITION CONTROL SYSTEM

CAUTION:

After repairing or replacing the defective part, perform the Clear Memory Mode <Ref. to EN(H4DOTC)(diag)-50, OPERATION, Clear Memory Mode.> and Inspection Mode <Ref. to EN(H4DOTC)(diag)-38, PROCEDURE, Inspection Mode.>.

WIRING DIAGRAM:

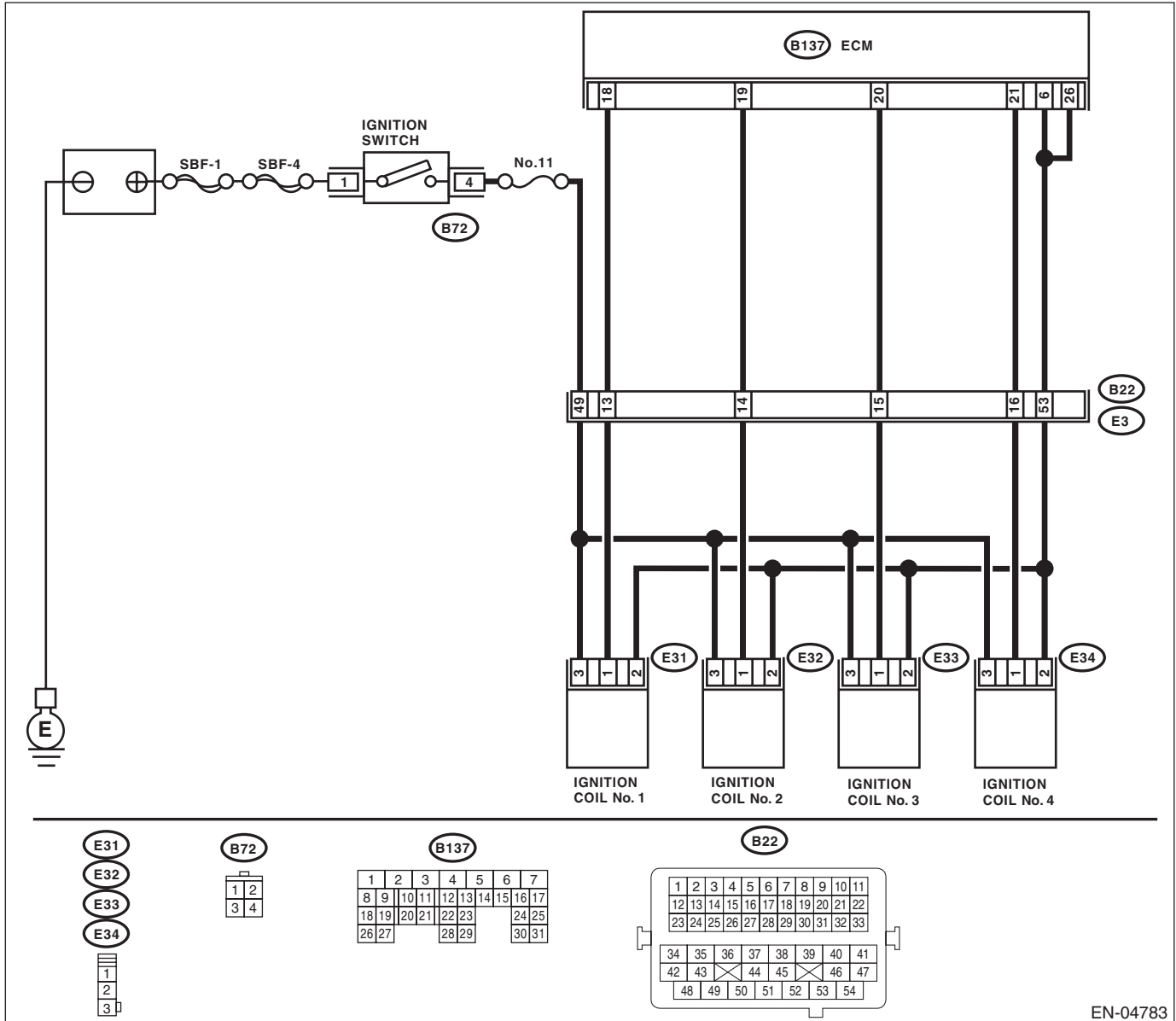

EN-04783

Diagnostics for Engine Starting Failure

ENGINE (DIAGNOSTICS)

Step	Check	Yes	No
1 CHECK SPARK PLUG CONDITION. 1) Remove the spark plug. <Ref. to IG(H4DOTC)-4, REMOVAL, Spark Plug.> 2) Check the spark plug condition. <Ref. to IG(H4DOTC)-5, INSPECTION, Spark Plug.>	Is the spark plug condition status OK?	Go to step 2.	Replace the spark plug.
2 CHECK IGNITION SYSTEM FOR SPARKS. 1) Connect the spark plug to ignition coil. 2) Release the fuel pressure. <Ref. to FU(H4DOTC)-49, RELEASING OF FUEL PRESSURE, PROCEDURE, Fuel.> 3) Contact the spark plug's thread portion to the engine. 4) While opening the throttle valve fully, crank the engine to check that spark occurs at each cylinder.	Does spark occur at each cylinder?	Check fuel pump system. <Ref. to EN(H4DOTC)(diag)-67, FUEL PUMP CIRCUIT, Diagnostics for Engine Starting Failure.>	Go to step 3.
3 CHECK POWER SUPPLY CIRCUIT FOR IGNITION COIL AND IGNITOR ASSEMBLY. 1) Turn the ignition switch to OFF. 2) Disconnect the connector from ignition coil and ignitor assembly. 3) Turn the ignition switch to ON. 4) Measure the power supply voltage between ignition coil and ignitor assembly connector and engine ground. <i>Connector & terminal</i> (E31) No. 3 (+) — Engine ground (-): (E32) No. 3 (+) — Engine ground (-): (E33) No. 3 (+) — Engine ground (-): (E34) No. 3 (+) — Engine ground (-):	Is the voltage 10 V or more?	Go to step 4.	Repair the harness and connector. NOTE: In this case, repair the following item: • Open circuit in harness between the ignition coil and ignitor assembly and ignition switch connector • Poor contact in coupling connector
4 CHECK HARNESS OF IGNITION COIL AND IGNITOR ASSEMBLY GROUND CIRCUIT. 1) Turn the ignition switch to OFF. 2) Measure the resistance between the ignition coil and ignitor assembly connector and the ECM. <i>Connector & terminal</i> (E31) No. 2 — (B137) No. 6, 26: (E32) No. 2 — (B137) No. 6, 26: (E33) No. 2 — (B137) No. 6, 26: (E34) No. 2 — (B137) No. 6, 26:	Is the resistance less than 5 Ω?	Go to step 5.	Repair the harness and connector. NOTE: In this case, repair the following item: • Open circuit in harness between ECM and ignition coil and ignitor assembly connector
5 CHECK HARNESS BETWEEN ECM AND IGNITION COIL AND IGNITOR ASSEMBLY CONNECTOR. 1) Turn the ignition switch to OFF. 2) Disconnect the connectors from ECM. 3) Disconnect the connector from ignition coil and ignitor assembly. 4) Measure the resistance of harness between ECM and ignition coil and ignitor assembly connector. <i>Connector & terminal</i> (B137) No. 21 — (E34) No. 1: (B137) No. 20 — (E33) No. 1: (B137) No. 19 — (E32) No. 1: (B137) No. 18 — (E31) No. 1:	Is the resistance less than 1 Ω?	Go to step 6.	Repair the harness and connector. NOTE: In this case, repair the following item: • Open circuit in harness between ECM and ignition coil and ignitor assembly connector • Poor contact in coupling connector

Diagnostics for Engine Starting Failure

ENGINE (DIAGNOSTICS)

Step	Check	Yes	No
6 CHECK HARNESS BETWEEN ECM AND IGNITION COIL AND IGNITOR ASSEMBLY CONNECTOR. Measure the resistance of harness between ECM and engine ground. <i>Connector & terminal</i> <i>(B137) No. 21 — Engine ground:</i> <i>(B137) No. 20 — Engine ground:</i> <i>(B137) No. 19 — Engine ground:</i> <i>(B137) No. 18 — Engine ground:</i>	Is the resistance 1 MΩ or more?	Go to step 7.	Repair the ground short circuit of harness between ECM and ignition coil and ignitor assembly connector.
7 CHECK POOR CONTACT. Check poor contact of ECM connector.	Is there poor contact in ECM connector?	Repair poor contact in ECM connector.	Check fuel pump circuit. <Ref. to EN(H4DOTC)(diag)-67, FUEL PUMP CIRCUIT, Diagnostics for Engine Starting Failure.>

E: FUEL PUMP CIRCUIT

CAUTION:

After repairing or replacing the defective part, perform the Clear Memory Mode <Ref. to EN(H4DOTC)(diag)-50, OPERATION, Clear Memory Mode.> and Inspection Mode <Ref. to EN(H4DOTC)(diag)-38, PROCEDURE, Inspection Mode.>.

WIRING DIAGRAM:

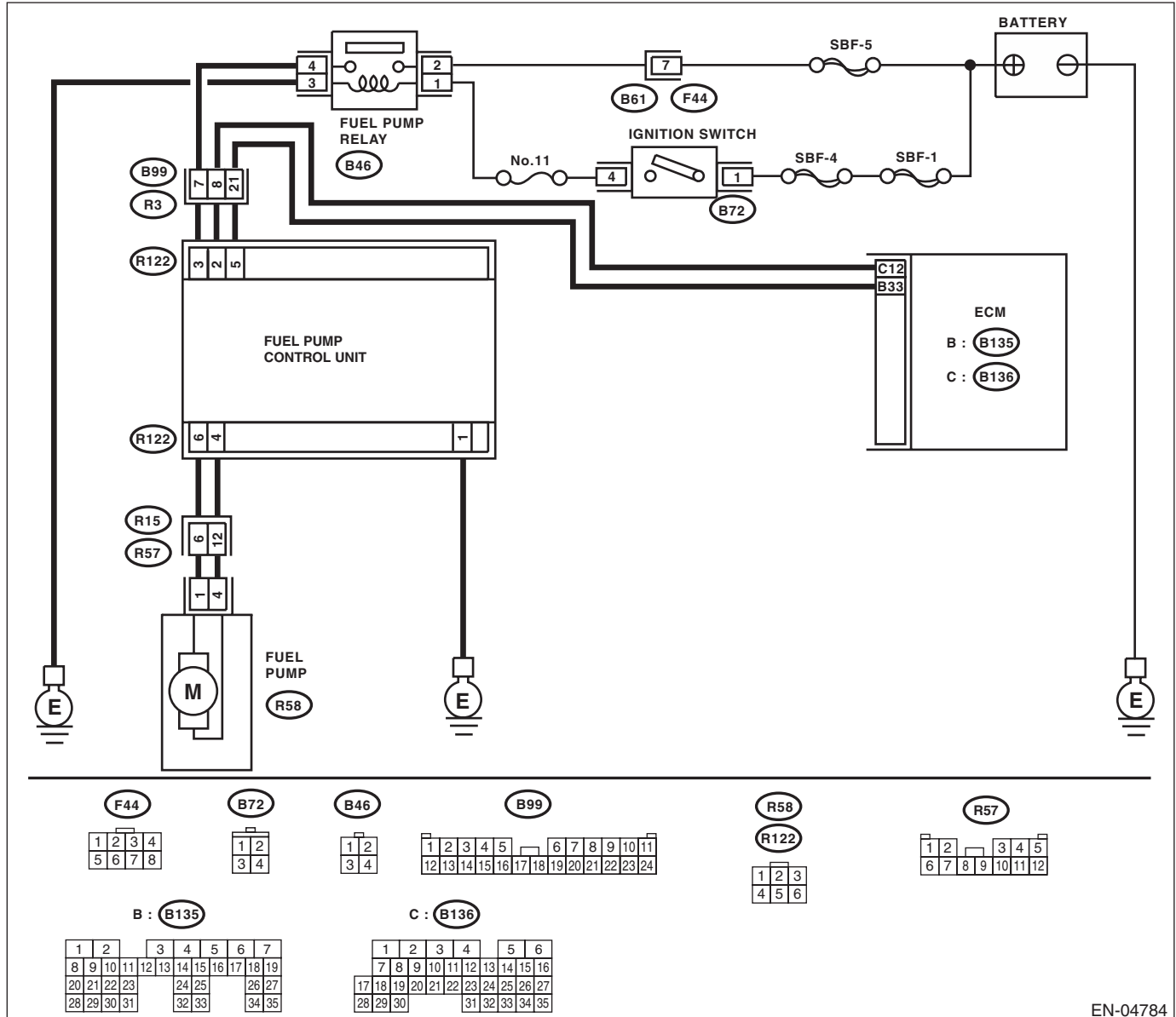

EN-04784

Step	Check	Yes	No
<p>1</p> <p>CHECK OPERATING SOUND OF FUEL PUMP.</p> <p>Make sure that the fuel pump operates for 2 seconds when turning the ignition switch to ON.</p> <p>NOTE: Fuel pump operation check can also be executed using Subaru Select Monitor.</p> <p>For procedure, refer to "Compulsory Valve Operation Check Mode". <Ref. to EN(H4DOTC)(diag)-51, Compulsory Valve Operation Check Mode.></p>	<p>Does the fuel pump emit operating sound?</p>	<p>Check the fuel injector circuit.</p> <p><Ref. to EN(H4DOTC)(diag)-68, FUEL INJECTOR CIRCUIT, Diagnostics for Engine Starting Failure.></p>	<p>Display the DTC.</p> <p><Ref. to EN(H4DOTC)(diag)-37, OPERATION, Read Diagnostic Trouble Code (DTC).></p>

Diagnostics for Engine Starting Failure

ENGINE (DIAGNOSTICS)

F: FUEL INJECTOR CIRCUIT

CAUTION:

- Check or repair only faulty parts.
- After repairing or replacing the defective part, perform the Clear Memory Mode <Ref. to EN(H4DOTC)(diag)-50, OPERATION, Clear Memory Mode.> and Inspection Mode <Ref. to EN(H4DOTC)(diag)-38, PROCEDURE, Inspection Mode.>.

WIRING DIAGRAM:

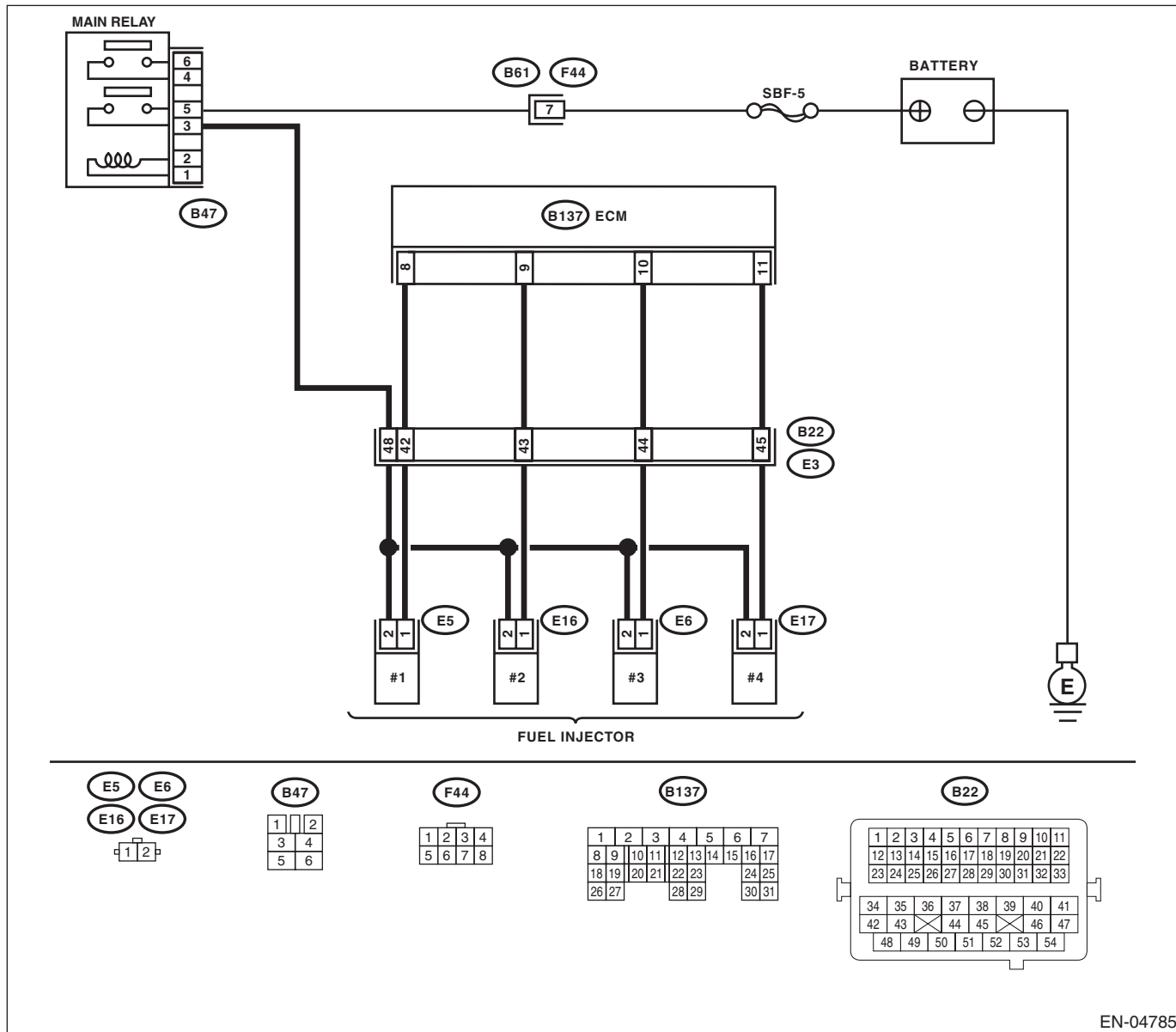

EN-04785

Diagnostics for Engine Starting Failure

ENGINE (DIAGNOSTICS)

Step	Check	Yes	No
<p>1 CHECK OPERATION OF EACH FUEL INJECTOR. While cranking the engine, check each fuel injector emits operating sound. Use a sound scope or attach a screwdriver to the injector for this check.</p>	Does the fuel injector emit operating sound?	Check the fuel pressure. <Ref. to ME(H4DOTC)-27, INSPECTION, Fuel Pressure.>	Go to step 2.
<p>2 CHECK POWER SUPPLY TO EACH FUEL INJECTOR. 1) Turn the ignition switch to OFF. 2) Disconnect the connector from fuel injector. 3) Turn the ignition switch to ON. 4) Measure the power supply voltage between fuel injector terminal and engine ground. Connector & terminal #1 (E5) No. 2 (+) — Engine ground (-): #2 (E16) No. 2 (+) — Engine ground (-): #3 (E6) No. 2 (+) — Engine ground (-): #4 (E17) No. 2 (+) — Engine ground (-):</p>	Is the voltage 10 V or more?	Go to step 3.	Repair the harness and connector. NOTE: In this case, repair the following item: • Open circuit in harness between main relay and fuel injector connector • Poor contact in main relay connector • Poor contact in coupling connector • Poor contact in fuel injector connector
<p>3 CHECK HARNESS BETWEEN ECM AND FUEL INJECTOR CONNECTOR. 1) Disconnect the connectors from ECM. 2) Measure the resistance of harness between ECM and fuel injector connector. Connector & terminal (B137) No. 8 — (E5) No. 1: (B137) No. 9 — (E16) No. 1: (B137) No. 10 — (E6) No. 1: (B137) No. 11 — (E17) No. 1:</p>	Is the resistance less than 1 Ω?	Go to step 4.	Repair the harness and connector. NOTE: In this case, repair the following item: • Open circuit in harness between ECM and fuel injector connector • Poor contact in coupling connector
<p>4 CHECK HARNESS BETWEEN ECM AND FUEL INJECTOR CONNECTOR. Measure the resistance of harness between ECM and fuel injector connector. Connector & terminal (B137) No. 8 — Chassis ground: (B137) No. 9 — Chassis ground: (B137) No. 10 — Chassis ground: (B137) No. 11 — Chassis ground:</p>	Is the resistance less than 1 Ω?	Repair the ground short circuit of harness between ECM and fuel injector connector.	Go to step 5.
<p>5 CHECK EACH FUEL INJECTOR. 1) Turn the ignition switch to OFF. 2) Measure the resistance between each fuel injector terminals. Terminals No. 1 — No. 2:</p>	Is the resistance between 5 — 20 Ω?	Go to step 6.	Replace the faulty fuel injector.
<p>6 CHECK POOR CONTACT. Check poor contact of ECM connector.</p>	Is there poor contact in ECM connector?	Repair poor contact in ECM connector.	Inspection using “General Diagnostic Table” <Ref. to EN(H4DOTC)(diag)-400, INSPECTION, General Diagnostic Table.>