

Center Exhaust Pipe

EXHAUST

3. Center Exhaust Pipe

A: REMOVAL

- 1) Set the vehicle on a lift.
- 2) Disconnect the ground cable from battery.
- 3) Remove the collector cover.
- 4) Remove the intercooler. <Ref. to IN(H4DOTC)-11, REMOVAL, Intercooler.>
- 5) Remove the intercooler bracket.

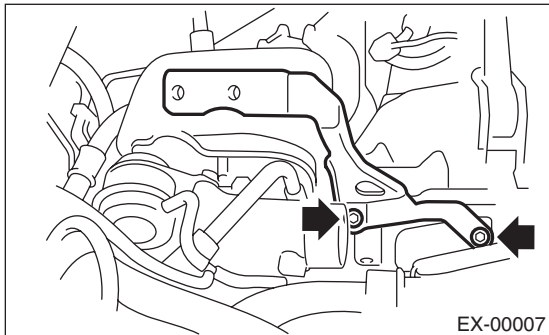

- 6) Lift-up the vehicle.
- 7) Remove the under cover.
- 8) Remove the bolts which install the lower side of turbocharger upper cover.

CAUTION:

Be careful, the turbocharger and exhaust pipe are hot.

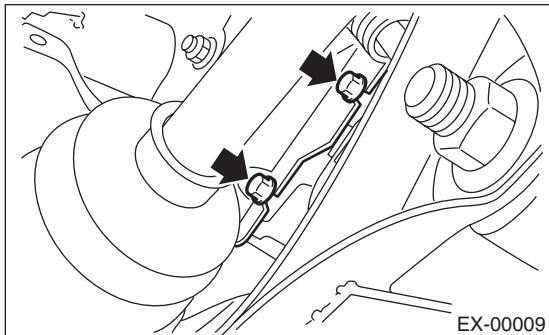

- 9) Lower the vehicle.
- 10) Remove the turbocharger upper cover.

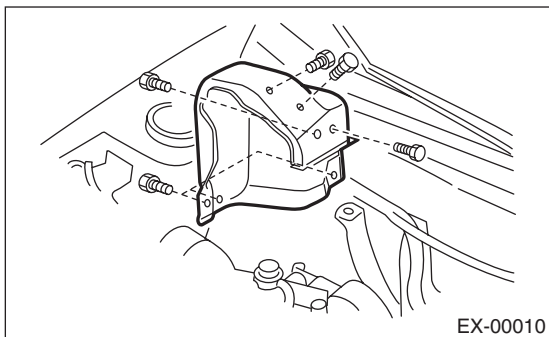

- 11) Remove the bolts which install the upper side of turbocharger upper cover, and remove it.

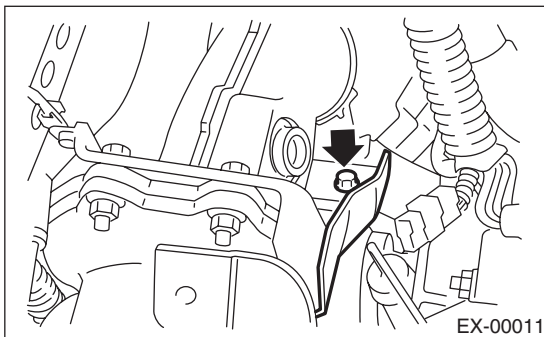

- 12) Separate the center exhaust pipe from turbocharger.

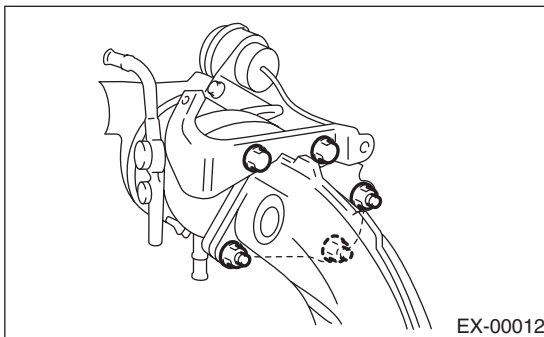

- 13) Lift-up the vehicle.
- 14) Disconnect the connector from rear oxygen sensor.

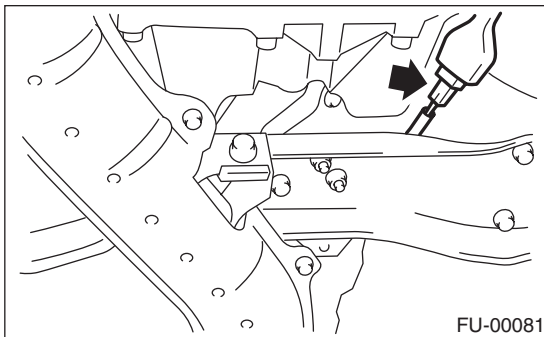

- 15) Vertically draw out clip from crossmember.

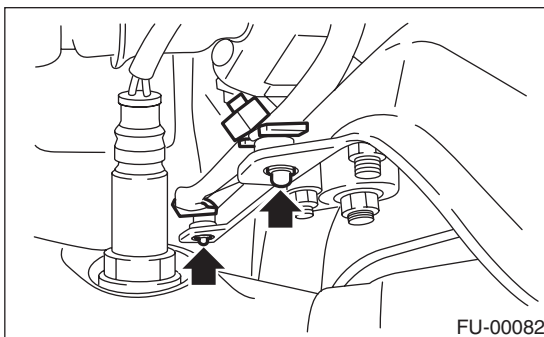

- 16) Separate the center exhaust pipe from rear exhaust pipe.

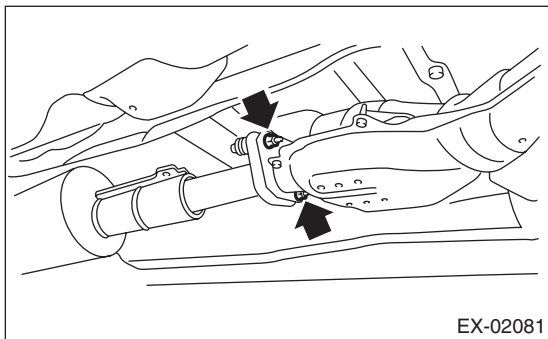

- 17) Remove the bolt which holds center exhaust pipe bracket to transmission.

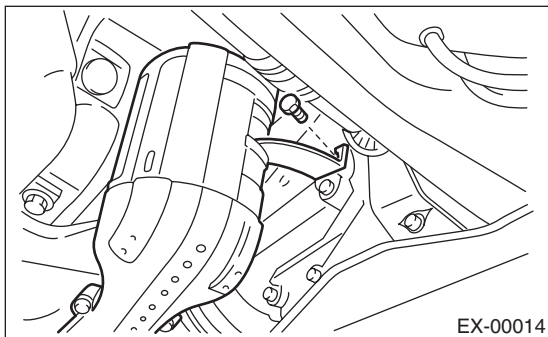

- 18) Remove the intercooler bracket.
19) Remove the bolt which holds center exhaust pipe to hanger bracket.

CAUTION:
Be careful not to pull down the center exhaust pipe.

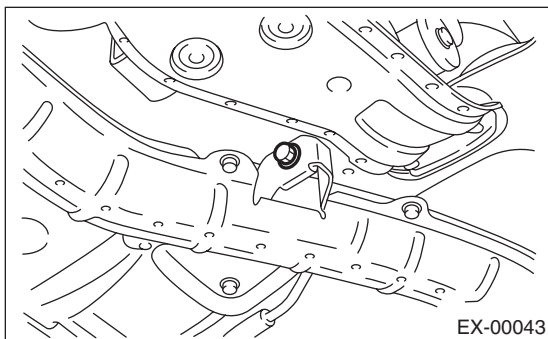

- 20) Remove the center exhaust pipe.



B: INSTALLATION

NOTE:

Use a new gasket.

- 1) Install the center exhaust pipe and temporarily tighten the bolt which holds center exhaust pipe to hanger bracket.
- 2) Temporarily tighten the bolt which holds the center pipe to transmission.
- 3) Connect the center exhaust pipe to turbocharger.

Tightening torque:

35 N·m (3.6 kgf·m, 26.0 ft·lb)

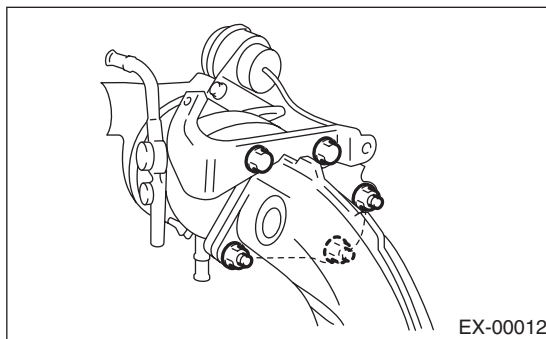

- 4) Install the center exhaust pipe to rear exhaust pipe.

Tightening torque:

18 N·m (1.8 kgf·m, 13.0 ft·lb)

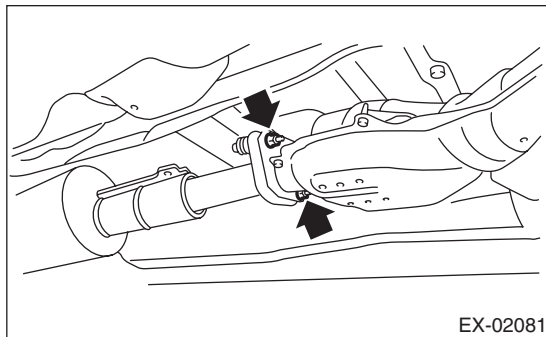

- 5) Connect the connector to rear oxygen sensor.

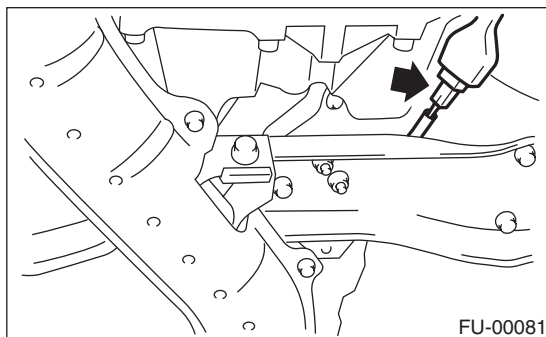

Center Exhaust Pipe

EXHAUST

6) Secure clip on the crossmember.

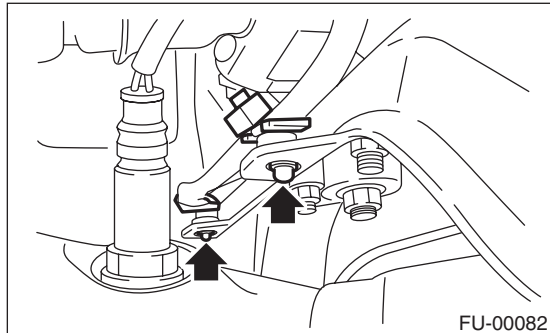

7) Tighten the bolt which holds center exhaust pipe bracket to transmission.

Tightening torque:

30 N·m (3.1 kgf·m, 22.4 ft-lb)

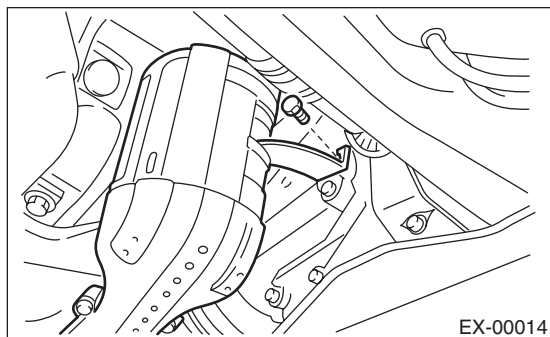

8) Tighten the bolt which holds center exhaust pipe to hanger bracket.

Tightening torque:

35 N·m (3.6 kgf·m, 26.0 ft-lb)

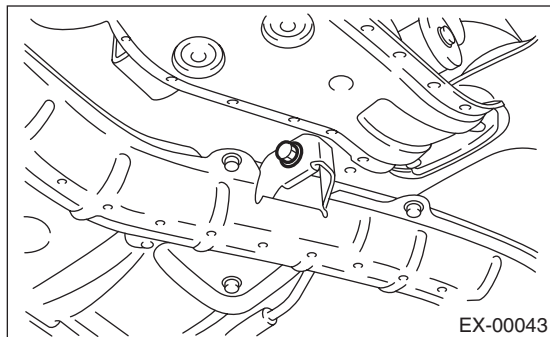

9) Tighten the bolts which hold the intercooler bracket.

Tightening torque:

35 N·m (3.6 kgf·m, 26.0 ft-lb)

10) Lower the vehicle.

11) Position the turbocharger lower cover, and tighten the bolts which install the upper side of lower cover.

Tightening torque:

7.5 N·m (0.8 kgf·m, 5.5 ft-lb)

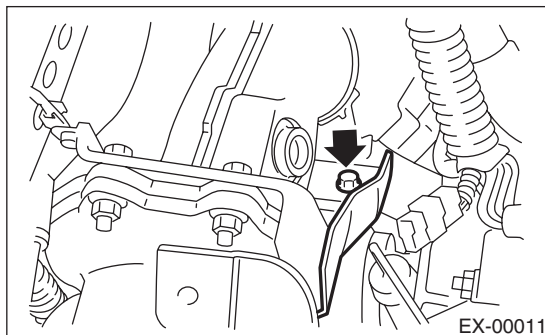

12) Position the turbocharger upper cover, and tighten the bolts which install the upper side of upper cover.

Tightening torque:

7.5 N·m (0.8 kgf·m, 5.5 ft-lb)

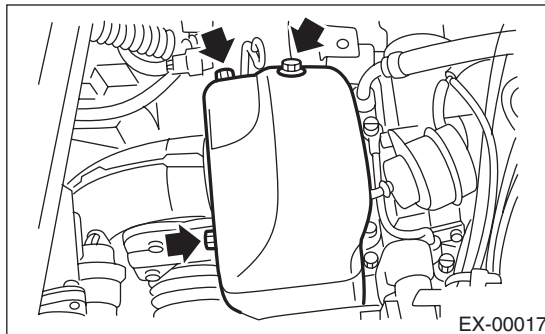

13) Lift-up the vehicle.

14) Tighten the bolts which install the under side of turbocharger upper cover.

Tightening torque:

7.5 N·m (0.8 kgf·m, 5.5 ft-lb)

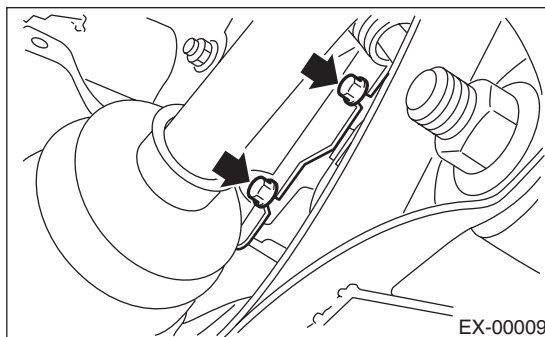

15) Install the universal joint.

(1) Align the bolt hole on the long yoke side of universal joint with the cutout at the serrated section of shaft end, and then insert the universal joint.

(2) Align the bolt hole on the short yoke side of universal joint with the cutout on the serrated section of gearbox assembly. Lower the universal joint completely.

(3) Temporarily tighten the bolt of short yoke side. Raise the universal joint to make sure the bolt is properly passing through the cutout at the serrated section.

(4) Tighten the long yoke side bolt, and also tighten the short yoke side bolt.

Tightening torque:

24 N·m (2.4 kgf·m, 17.4 ft·lb)

CAUTION:

- Make sure the universal joint bolts are tightened through the shaft serration notches.
- Excessively large tightening torque of universal joint bolts may lead to heavy steering wheel operation.

Standard clearance between gearbox and DOJ:

15 mm (0.59 in) or more

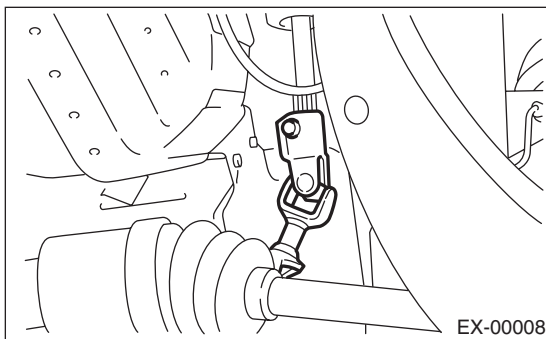

16) Install the under cover.

17) Lower the vehicle.

18) Install the intercooler bracket.

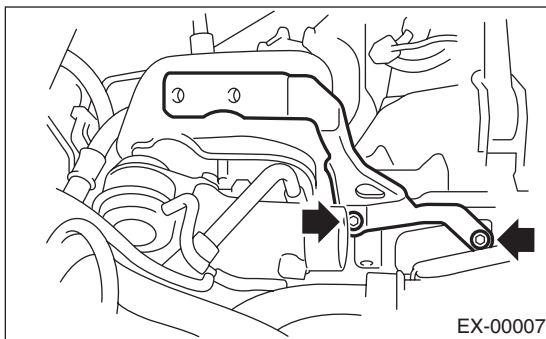

19) Install the intercooler. <Ref. to IN(H4DOTC)-11, INSTALLATION, Intercooler.>

20) Align the center of the roll connector. <Ref. to AB-20, ADJUSTMENT, Roll Connector.>

21) Install the collector cover.