

## 2. Diagnostic Trouble Code (DTC) Detecting Criteria

### A: DTC P0011 INTAKE CAMSHAFT POSITION - TIMING OVER-ADVANCED OR SYSTEM PERFORMANCE (BANK 1)

#### 1. OUTLINE OF DIAGNOSIS

Detect the malfunction of AVCS system.

There are two types of diagnosis: Crankshaft cam timing diagnosis, and slow response diagnosis. Either of these is performed according to the status of the engine while running.

#### 2. COMPONENT DESCRIPTION

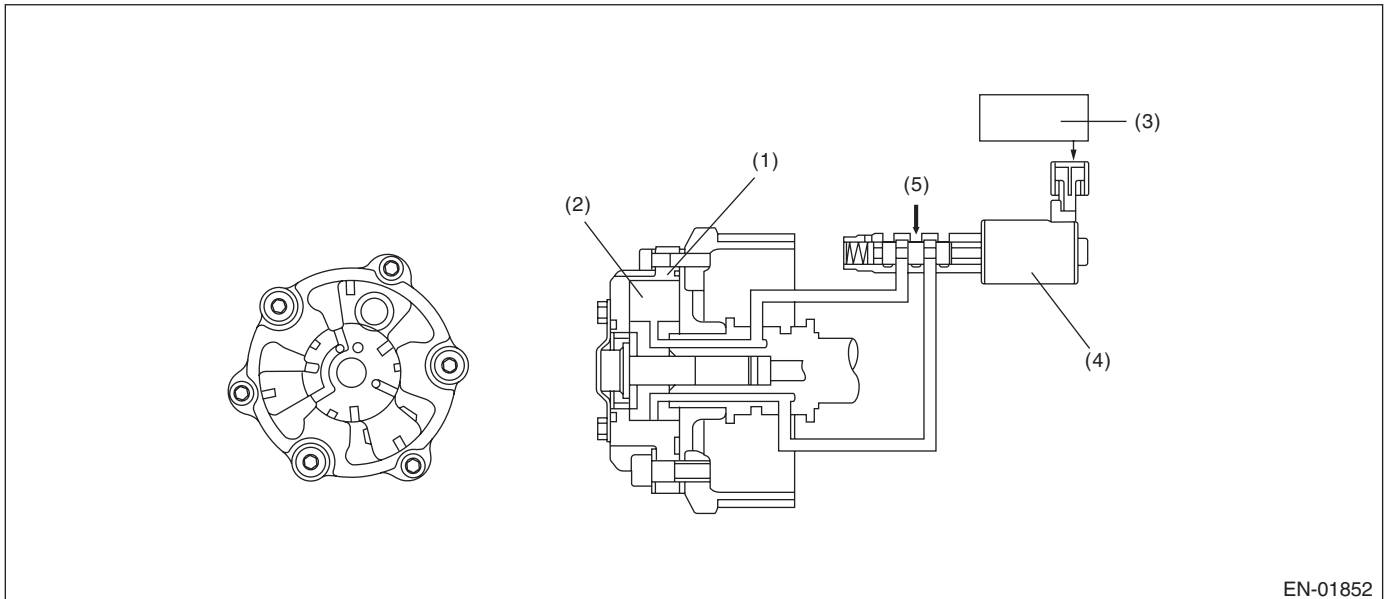

EN-01852

- (1) AVCS timing controller
- (2) Vane
- (3) Engine control module (ECM)
- (4) Oil flow control solenoid valve
- (5) Oil pressure
- (A) Air

# Diagnostic Trouble Code (DTC) Detecting Criteria

## GENERAL DESCRIPTION

---

### 3. ENABLE CONDITION

#### 1. Crankshaft Timing Diagnosis

Secondary Parameters	Enable Conditions
Battery voltage	$\geq 10.9 \text{ V}$
Engine coolant temperature	$> 60^{\circ}\text{C}$ ( $140^{\circ}\text{F}$ )
Target timing advance	$= 0^{\circ}\text{CA}$
Engine speed	$\geq 500 \text{ rpm}$
AVCS	Uncontrolled

#### 2. Slow Response Diagnosis

Secondary Parameters	Enable Conditions
All secondary parameters are executable.	1 second or more
Battery voltage	$\geq 10.9 \text{ V}$
Engine coolant temperature	$> 60^{\circ}\text{C}$ ( $140^{\circ}\text{F}$ )
Amount of AVCS target timing advance	$\neq 0^{\circ}\text{CA}$
Engine speed	$\geq 1300 \text{ rpm}$
AVCS	Controlled
Target timing advance change amount	$< 1.07^{\circ}\text{CA}$

### 4. GENERAL DRIVING CYCLE

#### 1. Crankshaft Timing Diagnosis

Perform the diagnosis continuously after starting engine and while AVCS is not operating.

#### 2. Slow Response Diagnosis

Perform the diagnosis continuously after starting engine and while AVCS is operating.

### 5. DIAGNOSTIC METHOD

#### 1. Crankshaft Timing Diagnosis

Judge as NG when the timing advance is outside the normal range. Judge as OK when it within the normal range.

Judge as NG when all the following conditions are established and the continuous time is more than 20 seconds. Judge as OK and clear the NG when the following conditions are not established and the continuous time is more than one second.

#### Judgment Value

Malfunction Criteria	Threshold Value
Basic timing advance	$< -13^{\circ}\text{CA}$ or $> 25^{\circ}\text{CA}$

**Time Needed for Diagnosis: 20 seconds**

**Malfunction Indicator Light Illumination:** Illuminates when malfunction occurs in 2 continuous driving cycles.

# Diagnostic Trouble Code (DTC) Detecting Criteria

GENERAL DESCRIPTION

## 2. Slow Response Diagnosis

During AVCS control, calculate AVCS deviation separately for positive/negative, and when the calculated value per the set time (30 seconds) is large, this is judged as NG.

### Abnormality Judgment

When all of the following conditions are established, judged as OK.

### Judgment Value

Malfunction Criteria	Threshold Value
AVCS target position	$\geq 0^{\circ}\text{CA}$
AVCS positive deviation integrated value	$< 8000^{\circ}\text{CA}$ (R bank) $< 8000^{\circ}\text{CA}$ (L bank)
or	
AVCS negative deviation integrated value	$< -8000^{\circ}\text{CA}$ (R bank) $< -8000^{\circ}\text{CA}$ (L bank)

**Time Needed for Diagnosis: 30 seconds**

**Malfunction Indicator Light Illumination:** Illuminates when malfunction occurs in 2 continuous driving cycles.

### Normality Judgment

Judges OK when all of the following conditions are established, and clears the NG.

### Judgment Value

Malfunction Criteria	Threshold Value
AVCS target position	$\geq 0^{\circ}\text{CA}$
AVCS positive deviation integrated value	$\leq 8000^{\circ}\text{CA}$ (R bank) $\leq 8000^{\circ}\text{CA}$ (L bank)
or	
AVCS negative deviation integrated value	$\geq -8000^{\circ}\text{CA}$ (R bank) $\geq -8000^{\circ}\text{CA}$ (L bank)

## 6. DTC CLEAR CONDITION

- When the OK idling cycle is completed 40 times in a row
- When "Clear Memory" is performed

## 7. MALFUNCTION INDICATOR LIGHT CLEAR CONDITION

- When the OK driving cycle is completed 3 times in a row
- When "Clear Memory" is performed

## 8. FAIL SAFE

Make the oil flow control solenoid valve drive duty a predetermined value.

## 9. ECM OPERATION AT DTC SETTING

Memorize the freeze frame data. (For test mode \$02)

## Diagnostic Trouble Code (DTC) Detecting Criteria

### GENERAL DESCRIPTION

---

#### **B: DTC P0016 CRANKSHAFT POSITION - CAMSHAFT POSITION CORRELATION (BANK 1)**

NOTE:

For the diagnostic procedure, refer to DTC P0011. <Ref. to GD(H4DOTC)-9, DTC P0011 INTAKE CAM-SHAFT POSITION - TIMING OVER-ADVANCED OR SYSTEM PERFORMANCE (BANK 1), Diagnostic Trouble Code (DTC) Detecting Criteria.>

#### **C: DTC P0018 CRANKSHAFT POSITION - CAMSHAFT POSITION CORRELATION (BANK 2)**

NOTE:

For the diagnostic procedure, refer to DTC P0011. <Ref. to GD(H4DOTC)-9, DTC P0011 INTAKE CAM-SHAFT POSITION - TIMING OVER-ADVANCED OR SYSTEM PERFORMANCE (BANK 1), Diagnostic Trouble Code (DTC) Detecting Criteria.>

#### **D: DTC P0021 INTAKE CAMSHAFT POSITION - TIMING OVER-ADVANCED OR SYSTEM PERFORMANCE (BANK 2)**

NOTE:

For the diagnostic procedure, refer to DTC P0011. <Ref. to GD(H4DOTC)-9, DTC P0011 INTAKE CAM-SHAFT POSITION - TIMING OVER-ADVANCED OR SYSTEM PERFORMANCE (BANK 1), Diagnostic Trouble Code (DTC) Detecting Criteria.>

## E: DTC P0030 HO2S HEATER CONTROL CIRCUIT (BANK 1 SENSOR 1)

### 1. OUTLINE OF DIAGNOSIS

Detect functional errors of the front oxygen (A/F) sensor heater.

Judge as NG when it is determined that the front oxygen (A/F) sensor impedance is large by referring to the engine condition such as fuel shut-off in deceleration, etc.

### 2. COMPONENT DESCRIPTION

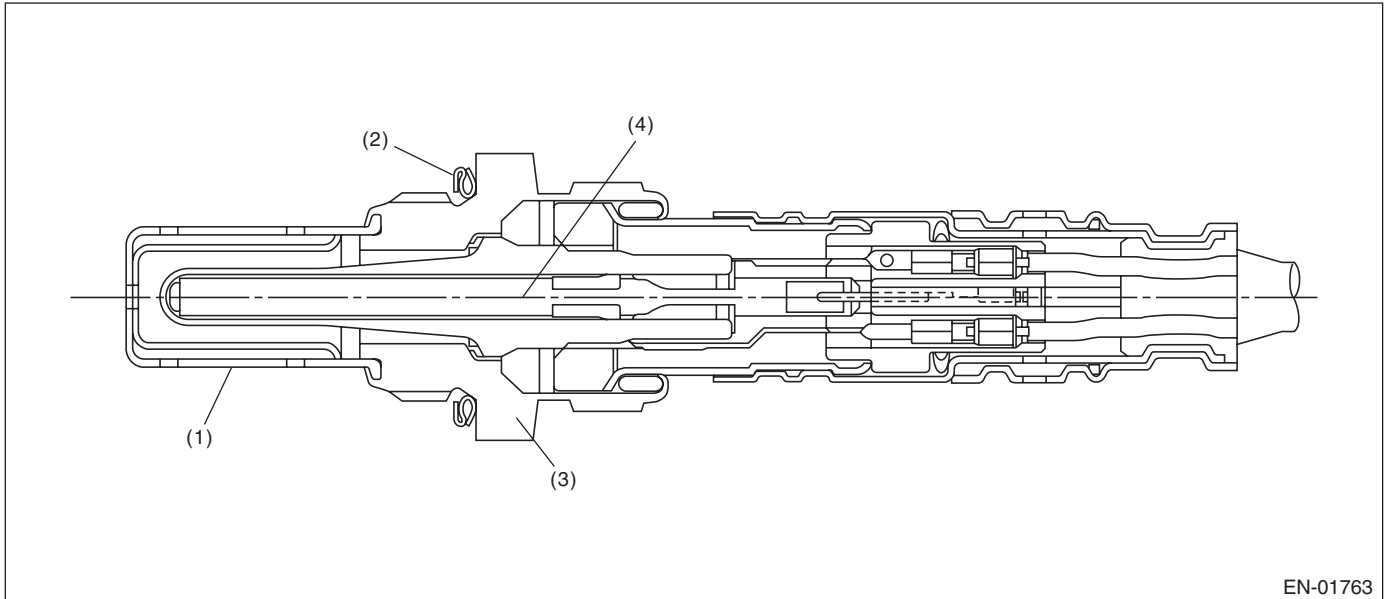

EN-01763

- (1) Protection tube
- (2) Gasket
- (3) Sensor housing
- (4) Ceramic heater

### 3. ENABLE CONDITION

Secondary Parameters	Enable Conditions
Time needed for all secondary parameters to be in enable conditions	30 seconds or more
Battery voltage	> 10.9 V
After fuel cut	10 seconds or more
Front oxygen (A/F) sensor heater control duty $\geq$ 35%	Experienced
Heater current	ON

### 4. GENERAL DRIVING CYCLE

Perform the diagnosis continuously after 30 seconds or more have passed since the engine started.

# Diagnostic Trouble Code (DTC) Detecting Criteria

## GENERAL DESCRIPTION

---

### 5. DIAGNOSTIC METHOD

Judge as NG when the continuous time of meeting the malfunction criteria below becomes more than 10 seconds. Judge as OK and clear NG when the continuous time of not completing the malfunction criteria below becomes more than 10 seconds.

#### Judgment Value

Malfunction Criteria	Threshold Value
Front oxygen (A/F) sensor impedance	> 50 $\Omega$

**Time Needed for Diagnosis:** 10 seconds

**Malfunction Indicator Light Illumination:** Illuminates when malfunction occurs in 2 continuous driving cycles.

### 6. DTC CLEAR CONDITION

- When the OK idling cycle is completed 40 times in a row
- When "Clear Memory" is performed

### 7. MALFUNCTION INDICATOR LIGHT CLEAR CONDITION

- When the OK driving cycle is completed 3 times in a row
- When "Clear Memory" is performed

### 8. FAIL SAFE

- Front oxygen sensor (A/F) sensor main learning compensation: Not allowed to calculate.
- Correction when re-starting at high temperature: Normally minimum value 0.3  $\rightarrow$  0.
- Purge control: Not allowed to purge.

### 9. ECM OPERATION AT DTC SETTING

Memorize the freeze frame data. (For test mode \$02)

## F: DTC P0031 HO2S HEATER CONTROL CIRCUIT LOW (BANK 1 SENSOR 1)

### 1. OUTLINE OF DIAGNOSIS

Detect the open or short circuit of heater.

The heater performs duty control, and the output terminal voltage at ON is 0 V and the output terminal voltage at OFF is the battery voltage.

Judge NG when the terminal voltage remains Low.

### 2. COMPONENT DESCRIPTION

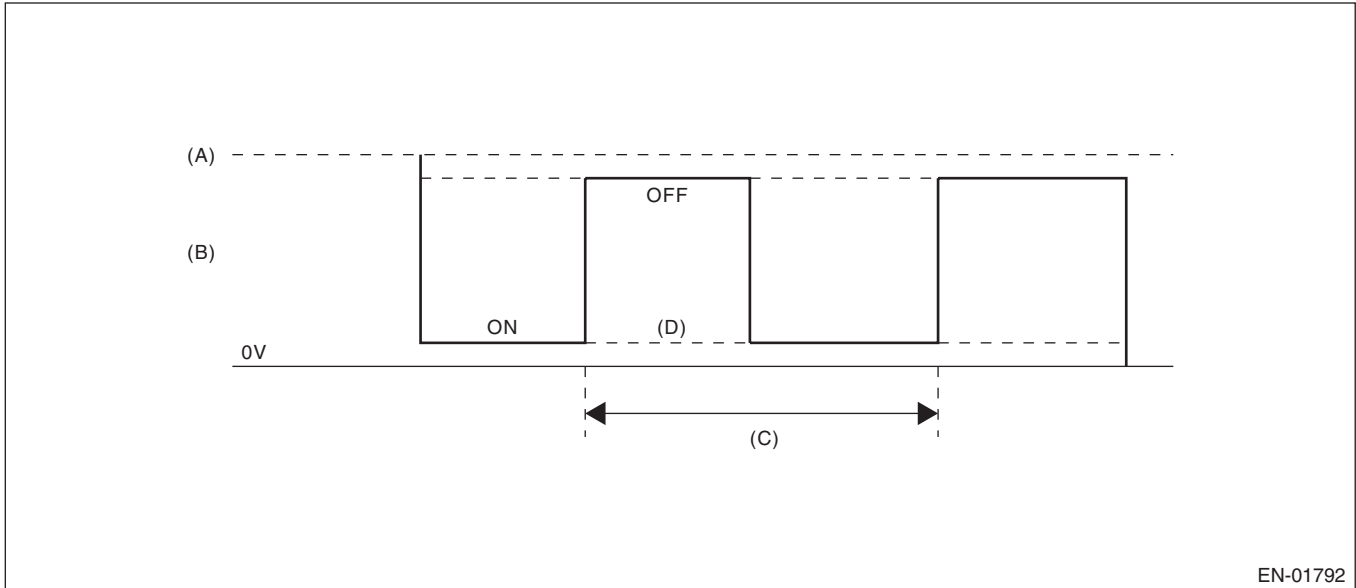

EN-01792

- (A) Battery voltage
- (B) Front oxygen (A/F) sensor heater output voltage
- (C) 128 milliseconds
- (D) Low error

### 3. ENABLE CONDITION

Secondary Parameters	Enable Conditions
Battery voltage	$\geq 10.9 \text{ V}$

### 4. GENERAL DRIVING CYCLE

Always perform the diagnosis continuously.

# Diagnostic Trouble Code (DTC) Detecting Criteria

## GENERAL DESCRIPTION

---

### 5. DIAGNOSTIC METHOD

#### Abnormality Judgment

Judge NG when the continuous time of meeting the malfunction criteria below becomes more than 1 second (8 cycles).

#### Judgment Value

Malfunction Criteria	Threshold Value
Output voltage level	Low
Front oxygen (A/F) sensor heater control duty	< 87.5%

**Time Needed for Diagnosis:** 1 second

**Malfunction Indicator Light Illumination:** Illuminates as soon as a malfunction occurs.

#### Normality Judgment

Judge as OK and clear the NG when the malfunction criteria below are completed.

#### Judgment Value

Malfunction Criteria	Threshold Value
Output voltage level	High

### 6. DTC CLEAR CONDITION

- When the OK idling cycle is completed 40 times in a row
- When "Clear Memory" is performed

### 7. MALFUNCTION INDICATOR LIGHT CLEAR CONDITION

- When the OK driving cycle is completed 3 times in a row
- When "Clear Memory" is performed

### 8. FAIL SAFE

- Front oxygen (A/F) sensor activation judgment: Front oxygen (A/F) sensor full activation is not complete, or front oxygen (A/F) sensor half activation is not complete.
- A/F main learning: Not allowed to calculate the A/F main learning compensation factor.
- Compensation when starting the engine at high temperature: Make the MIN value to be 0.3 → 0, normally.
- Purge control: Not allowed to purge.

### 9. ECM OPERATION AT DTC SETTING

Memorize the freeze frame data. (For test mode \$02)



## G: DTC P0032 HO2S HEATER CONTROL CIRCUIT HIGH (BANK 1 SENSOR 1)

### 1. OUTLINE OF DIAGNOSIS

Detect the open or short circuit of heater.

The heater performs duty control, and the output terminal voltage at ON is 0 V and the output terminal voltage at OFF is the battery voltage.

Judge NG when the terminal voltage remains High.

### 2. COMPONENT DESCRIPTION

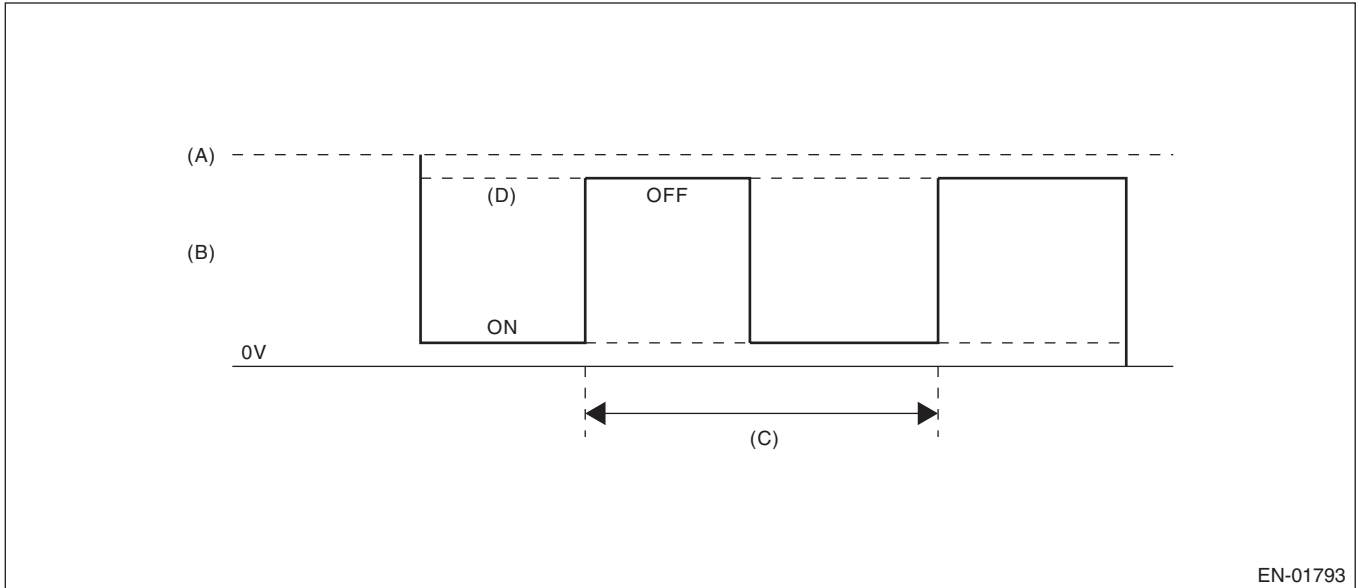

EN-01793

- (A) Battery voltage
- (B) Front oxygen (A/F) sensor heater output voltage
- (C) 128 milliseconds
- (D) High malfunction

### 3. ENABLE CONDITION

Secondary Parameters	Enable Conditions
Battery voltage	$\geq 10.9 \text{ V}$

### 4. GENERAL DRIVING CYCLE

Always perform the diagnosis continuously.

# Diagnostic Trouble Code (DTC) Detecting Criteria

## GENERAL DESCRIPTION

---

### 5. DIAGNOSTIC METHOD

#### Abnormality Judgment

Judge NG when the continuous time of meeting the malfunction criteria below becomes more than 1 second (8 cycles).

#### Judgment Value

Malfunction Criteria	Threshold Value
Output voltage level	High
Front oxygen (A/F) sensor heater control duty	≥ 12.5%

**Time Needed for Diagnosis:** 1 second

**Malfunction Indicator Light Illumination:** Illuminates as soon as a malfunction occurs.

#### Normality Judgment

Judge as OK and clear the NG when the malfunction criteria below are completed.

#### Judgment Value

Malfunction Criteria	Threshold Value
Output voltage level	Low

### 6. DTC CLEAR CONDITION

- When the OK idling cycle is completed 40 times in a row
- When "Clear Memory" is performed

### 7. MALFUNCTION INDICATOR LIGHT CLEAR CONDITION

- When the OK driving cycle is completed 3 times in a row
- When "Clear Memory" is performed

### 8. FAIL SAFE

- Front oxygen (A/F) sensor activation judgment: Front oxygen (A/F) sensor full activation is not complete, or front oxygen (A/F) sensor half activation is not complete.
- A/F main learning: Not allowed to calculate the A/F main learning compensation factor.
- Compensation when starting the engine at high temperature: Make the MIN value to be 0.3 → 0, normally.
- Purge control: Not allowed to purge.

### 9. ECM OPERATION AT DTC SETTING

Memorize the freeze frame data. (For test mode \$02)

## H: DTC P0037 HO2S HEATER CONTROL CIRCUIT LOW (BANK 1 SENSOR 2)

### 1. OUTLINE OF DIAGNOSIS

Detect the rear oxygen sensor heater open or short circuit.

The rear oxygen sensor heater performs duty control, and the output terminal voltage at ON is 0 V, and the output terminal voltage at OFF is the battery voltage.

Judge NG when the terminal voltage remains Low.

### 2. COMPONENT DESCRIPTION

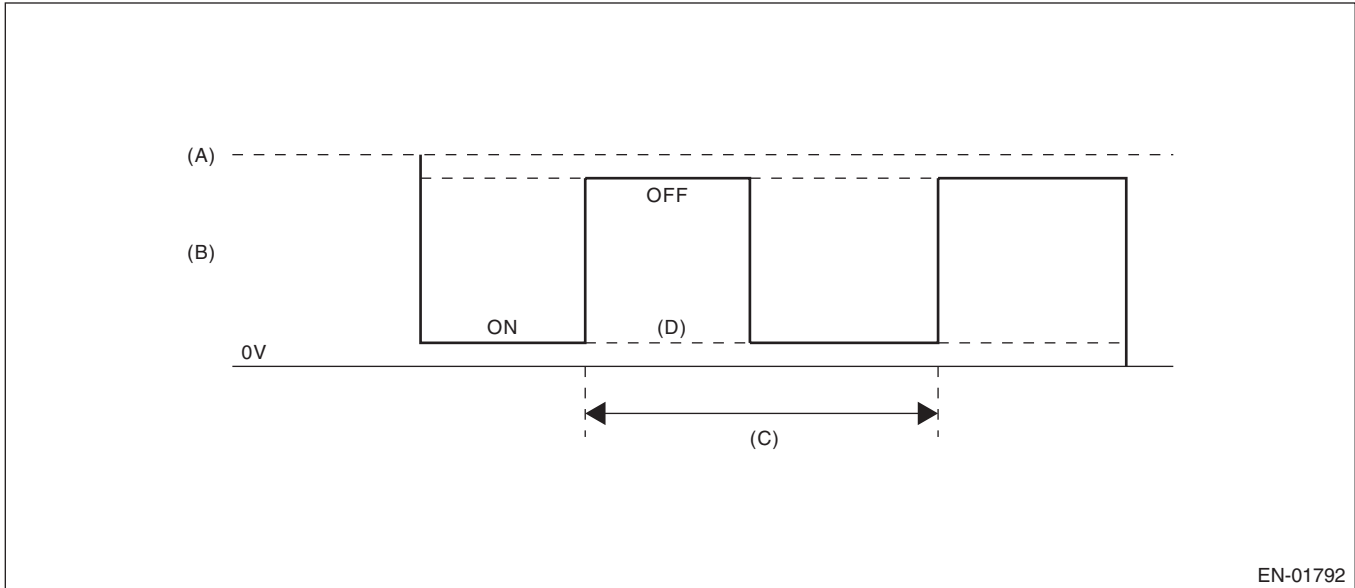

- (A) Battery voltage
- (B) Rear oxygen sensor heater output voltage
- (C) 256 milliseconds (cycles)
- (D) Low error

### 3. ENABLE CONDITION

Secondary Parameters	Enable Conditions
Battery voltage	> 10.9 V

### 4. GENERAL DRIVING CYCLE

Perform the diagnosis continuously after starting the engine.

# Diagnostic Trouble Code (DTC) Detecting Criteria

## GENERAL DESCRIPTION

---

### 5. DIAGNOSTIC METHOD

#### Abnormality Judgment

Judge as NG when the continuous time while meeting all of the malfunction criteria below is more than 2560 milliseconds (10 cycles).

#### Judgment Value

Malfunction Criteria	Threshold Value
Output voltage level	Low
Rear oxygen sensor heater control duty	< 75%

**Time Needed for Diagnosis:** 2.56 seconds

**Malfunction Indicator Light Illumination:** Illuminates when malfunction occurs in 2 continuous driving cycles.

#### Normality Judgment

Judge as OK and clear the NG when the malfunction criteria below are completed.

#### Judgment Value

Malfunction Criteria	Threshold Value
Output voltage level	High

### 6. DTC CLEAR CONDITION

- When the OK idling cycle is completed 40 times in a row
- When "Clear Memory" is performed

### 7. MALFUNCTION INDICATOR LIGHT CLEAR CONDITION

- When the OK driving cycle is completed 3 times in a row
- When "Clear Memory" is performed

### 8. FAIL SAFE

Sub feedback control: Not allowed

### 9. ECM OPERATION AT DTC SETTING

Memorize the freeze frame data. (For test mode \$02)

# Diagnostic Trouble Code (DTC) Detecting Criteria

GENERAL DESCRIPTION

## I: DTC P0038 HO2S HEATER CONTROL CIRCUIT HIGH (BANK 1 SENSOR 2)

### 1. OUTLINE OF DIAGNOSIS

Detect the rear oxygen sensor heater open or short circuit.

The rear oxygen sensor heater performs duty control, and the output terminal voltage at ON is 0 V, and the output terminal voltage at OFF is the battery voltage.

Judge NG when the terminal voltage remains High.

### 2. COMPONENT DESCRIPTION

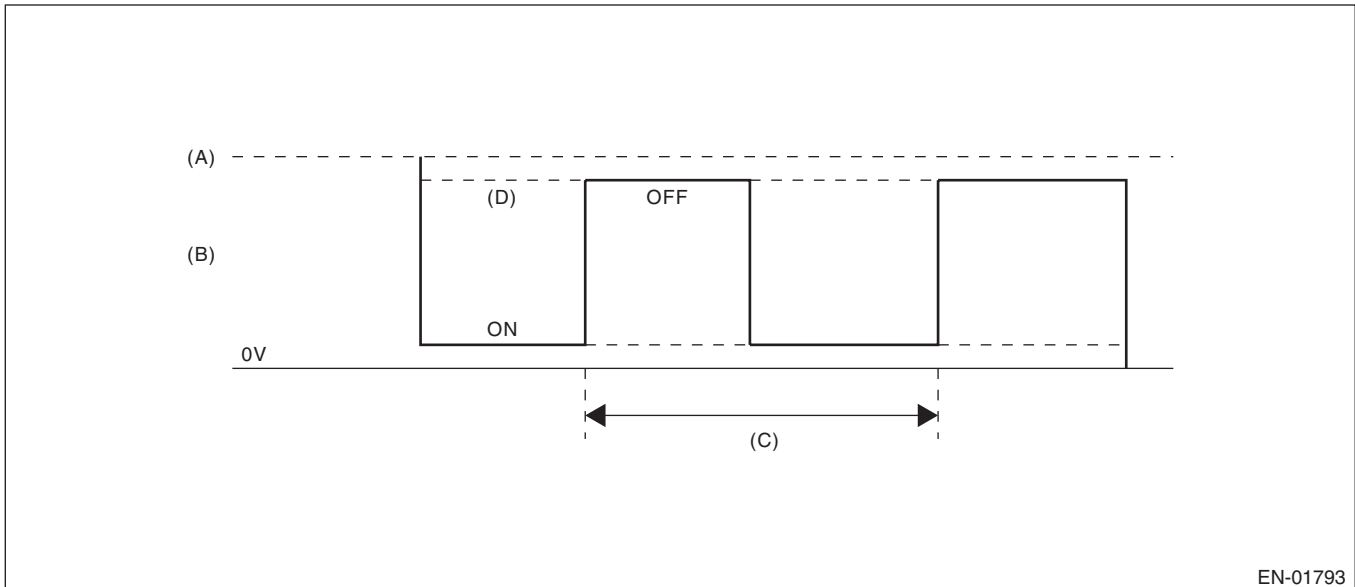

- (A) Battery voltage
- (B) Rear oxygen sensor heater output voltage
- (C) 256 milliseconds (cycles)
- (D) High malfunction

### 3. ENABLE CONDITION

Secondary Parameters	Enable Conditions
Battery voltage	> 10.9 V

### 4. GENERAL DRIVING CYCLE

Perform the diagnosis continuously after starting the engine.

# Diagnostic Trouble Code (DTC) Detecting Criteria

## GENERAL DESCRIPTION

---

### 5. DIAGNOSTIC METHOD

#### Abnormality Judgment

Judge as NG when the continuous time while meeting all of the malfunction criteria below is more than 2560 milliseconds (10 cycles).

#### Judgment Value

Malfunction Criteria	Threshold Value
Output voltage level	High
Rear oxygen sensor heater control duty	≥ 25%

**Time Needed for Diagnosis:** 2.56 seconds

**Malfunction Indicator Light Illumination:** Illuminates when malfunction occurs in 2 continuous driving cycles.

#### Normality Judgment

Judge as OK and clear the NG when the malfunction criteria below are completed.

#### Judgment Value

Malfunction Criteria	Threshold Value
Output voltage level	Low

### 6. DTC CLEAR CONDITION

- When the OK idling cycle is completed 40 times in a row
- When "Clear Memory" is performed

### 7. MALFUNCTION INDICATOR LIGHT CLEAR CONDITION

- When the OK driving cycle is completed 3 times in a row
- When "Clear Memory" is performed

### 8. FAIL SAFE

Sub feedback control: Not allowed

### 9. ECM OPERATION AT DTC SETTING

Memorize the freeze frame data. (For test mode \$02)

# Diagnostic Trouble Code (DTC) Detecting Criteria

GENERAL DESCRIPTION

## J: DTC P0068 MAP/MAF - THROTTLE POSITION CORRELATION

### 1. OUTLINE OF DIAGNOSIS

Detect the malfunction of intake manifold pressure sensor output property. Judge NG when the intake air pressure AD value is Low whereas it seemed to be High from the viewpoint of engine condition, or when it is High whereas it seemed to be Low from the engine condition.

### 2. COMPONENT DESCRIPTION

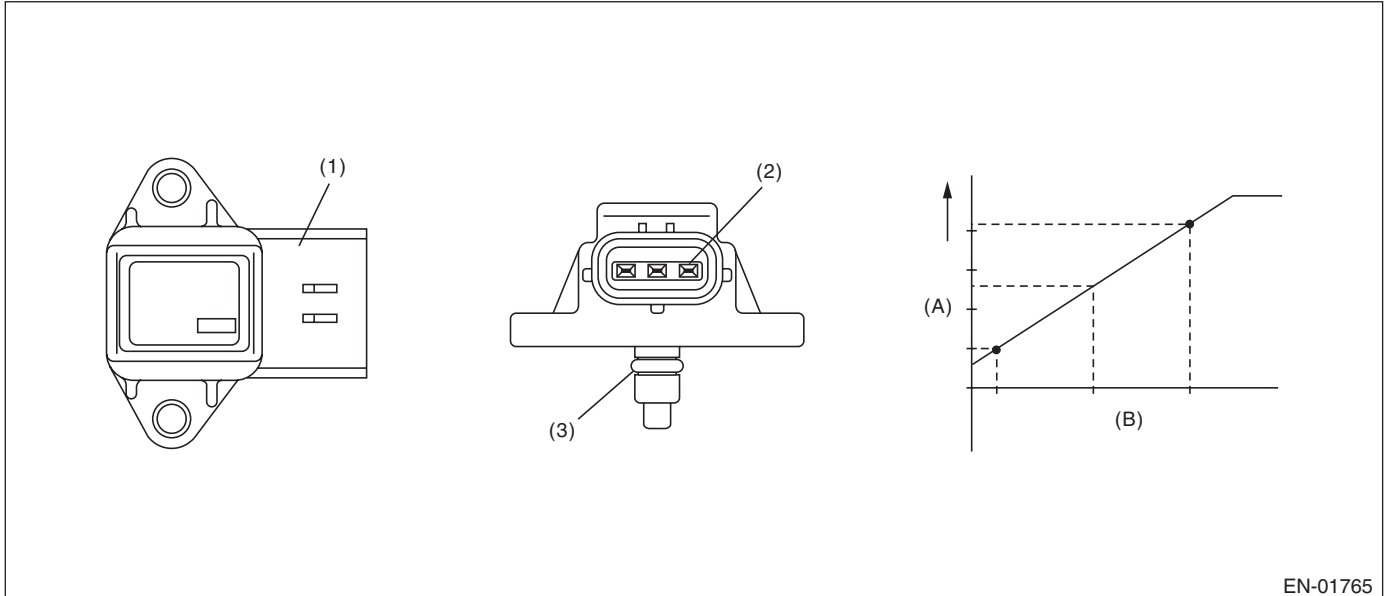

(1) Connector

(2) Terminal

(3) O-ring

(A) Output voltage

(B) Absolute pressure

EN-01765

### 3. ENABLE CONDITION

Secondary Parameters	Enable Conditions
Engine coolant temperature	$\geq 70^{\circ}\text{C}$ ( $158^{\circ}\text{F}$ )

### 4. GENERAL DRIVING CYCLE

Perform the diagnosis continuously after idling.

# Diagnostic Trouble Code (DTC) Detecting Criteria

## GENERAL DESCRIPTION

---

### 5. DIAGNOSTIC METHOD

#### Abnormality Judgment

Judge NG when either Low side or High side becomes NG.

Judge as NG when the continuous time of meeting the malfunction criteria below becomes 3 seconds or more.

#### Judgment Value

Malfunction Criteria	Threshold Value
Low side	
Engine speed	< 2500 rpm
Throttle position	$\geq 10^\circ$
Intake air amount every 0.5 engine revs.	> 1.356 g/rev
Output voltage	< 1.0 V
High side	
Engine speed	600 — 900 rpm
Throttle position	< $1.3^\circ$
Intake air amount every 0.5 engine revs.	< 0.4 g/rev
Output voltage	$\geq 2.36$ V

**Time Needed for Diagnosis:** 3 seconds

**Malfunction Indicator Light Illumination:** Illuminates when malfunction occurs in 2 continuous driving cycles.

#### Normality Judgment

Judge as OK and clear the NG when both Low side and High side become OK.

Judge as OK when the malfunction criteria below are completed.

#### Judgment Value

Malfunction Criteria	Threshold Value
Low side	
Engine speed	< 2500 rpm
Throttle position	$\geq 10^\circ$
Output voltage	$\geq 1.0$ V
High side	
Engine speed	600 — 900 rpm
Throttle position	< $1.3^\circ$
Output voltage	< 2.36 V

### 6. DTC CLEAR CONDITION

- When the OK idling cycle is completed 40 times in a row
- When "Clear Memory" is performed

### 7. MALFUNCTION INDICATOR LIGHT CLEAR CONDITION

- When the OK driving cycle is completed 3 times in a row
- When "Clear Memory" is performed

### 8. FAIL SAFE

- Intake manifold pressure sensor process: Estimate the pressure from engine load.
- ISC feedback: Not allowed to calculate the amount of feedback.
- Heavy fuel judgment: Not allowed to carry out the heavy judgment.
- Fuel cut control: Not allowed to cut the over pressure charged fuel.

### 9. ECM OPERATION AT DTC SETTING

Memorize the freeze frame data. (For test mode \$02)



# Diagnostic Trouble Code (DTC) Detecting Criteria

GENERAL DESCRIPTION

## K: DTC P0101 MASS OR VOLUME AIR FLOW CIRCUIT RANGE/PERFORMANCE

### 1. OUTLINE OF DIAGNOSIS

Detect the malfunction of air flow sensor output property.

Judge as a low side NG when the air flow voltage indicates a small value regardless of running in a state where the air flow voltage increases. Judge as a high side NG when the air flow voltage indicates a large value regardless of running in a state where the air flow voltage decreases. Judge air flow sensor property NG when the Low side or High side becomes NG.

### 2. COMPONENT DESCRIPTION

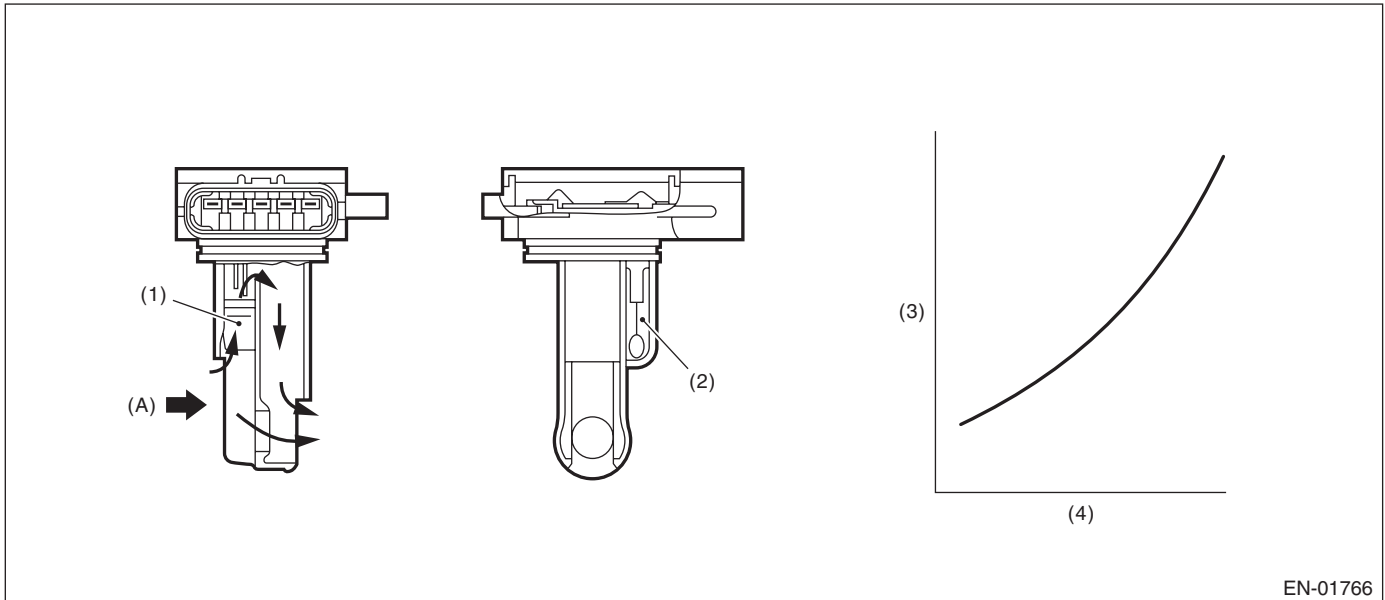

EN-01766

(1) Air flow sensor

(2) Intake air temperature sensor

(3) Voltage (V)

(4) Intake air volume (kg/s)

(A) Air

### 3. ENABLE CONDITION

Secondary Parameters	Enable Conditions
Engine coolant temperature	$\geq 70^{\circ}\text{C}$ ( $158^{\circ}\text{F}$ )

### 4. GENERAL DRIVING CYCLE

Perform the diagnosis continuously after idling.

# Diagnostic Trouble Code (DTC) Detecting Criteria

## GENERAL DESCRIPTION

---

### 5. DIAGNOSTIC METHOD

#### Abnormality Judgment

Judge as NG when the continuous time with the following criteria established exceeds the predetermined time.

#### Judgment Value

Malfunction Criteria	Threshold Value
(Low side error) Output voltage Engine speed Throttle opening angle Intake manifold pressure	< 1.5 V ≥ 2500 rpm ≥ 15° ≥ 53.3 kPa (400 mmHg, 15.7 inHg)
(High side error 1) Output voltage Engine speed Throttle opening angle Intake manifold pressure	≥ 1.95 V 600 — 900 rpm < 4.1° < 52.7 kPa (395 mmHg, 15.6 inHg)
(High side error 2) Output voltage Engine speed Throttle opening angle Intake manifold pressure Fuel system diagnosis	≥ 1.7 V 600 — 900 rpm < 4.1° < 52.7 kPa (395 mmHg, 15.6 inHg) Rich side fault

#### Time Needed for Diagnosis:

Low side: 3 seconds

High side: 10 seconds

**Malfunction Indicator Light Illumination:** Illuminates when malfunction occurs in 2 continuous driving cycles.

#### Normality Judgment

Judge as OK when the criteria below are met.

#### Judgment Value

Malfunction Criteria	Threshold Value
(Low side error) Output voltage Engine speed Throttle opening angle Intake manifold pressure	≥ 1.5 V ≥ 2500 rpm ≥ 15° ≥ 53.3 kPa (400 mmHg, 15.7 inHg)
(High side error) Output voltage Engine speed Throttle opening angle Intake manifold pressure	< 1.95 V 600 — 900 rpm < 4.1° < 52.7 kPa (395 mmHg, 15.6 inHg)

### 6. DTC CLEAR CONDITION

- When the OK idling cycle is completed 40 times in a row
- When "Clear Memory" is performed

# Diagnostic Trouble Code (DTC) Detecting Criteria

GENERAL DESCRIPTION

---

## 7. MALFUNCTION INDICATOR LIGHT CLEAR CONDITION

- When the OK driving cycle is completed 3 times in a row
- When “Clear Memory” is performed

## 8. FAIL SAFE

- Air flow meter: Engine load is normally calculated by manifold pressure and engine speed; however, calculated only by manifold pressure.
- EVAP conc. learning (fuel): Not allowed to learn.
- Knock compensation:
  - Knock compensation final advance/delay angle value = knock compensation value + whole learning compensation value + portional learning compensation value
  - When normal: Knock compensation value = Fixed at 0°CA
  - Failure: Knock compensation value ≠ Fixed at 0°CA. (When knock: Max. 12°CA retard)
  - Whole learning compensation coefficient update not allowed.
  - Portional learning zone compensation value calculation not allowed.
- ISC control: Open loop compensation is set to (1 g/s). Stop calculation of throttle sensor temperature compensation. (Hold the previous value.)
- Purge control: Not allowed to purge.

## 9. ECM OPERATION AT DTC SETTING

Memorize the freeze frame data. (For test mode \$02)

# Diagnostic Trouble Code (DTC) Detecting Criteria

## GENERAL DESCRIPTION

### L: DTC P0102 MASS OR VOLUME AIR FLOW CIRCUIT LOW INPUT

#### 1. OUTLINE OF DIAGNOSIS

Detect open or short circuits of the air flow sensor.  
Judge as NG if it is out of specification.

#### 2. COMPONENT DESCRIPTION

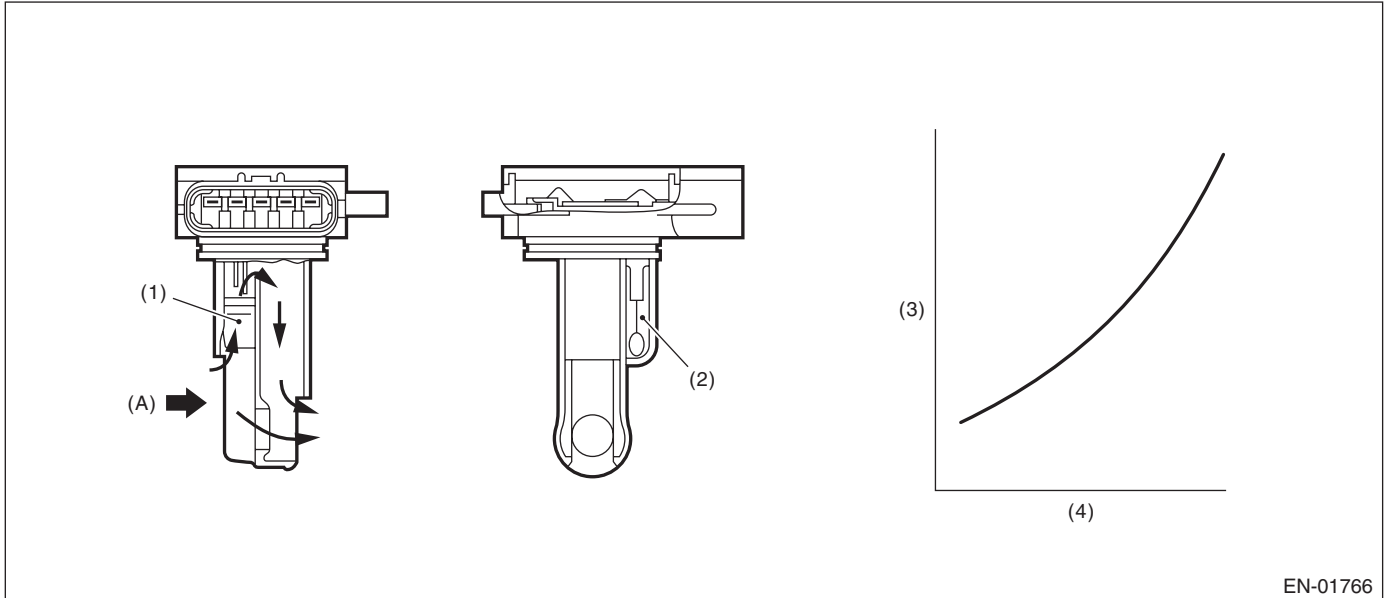

(1) Air flow sensor

(2) Intake air temperature sensor

(3) Voltage (V)

(4) Intake air volume (kg/s)

(A) Air

EN-01766

#### 3. ENABLE CONDITION

Secondary Parameters	Enable Conditions
None	

#### 4. GENERAL DRIVING CYCLE

Always perform the diagnosis continuously.

#### 5. DIAGNOSTIC METHOD

Judge as NG when the continuous time of meeting the malfunction criteria below becomes 0.5 seconds or more. Judge as OK and clear the NG when the malfunction criteria below are not met.

##### Judgment Value

Malfunction Criteria	Threshold Value
Output voltage	$\leq 0.2$ V

**Time Needed for Diagnosis:** 0.5 seconds

**Malfunction Indicator Light Illumination:** Illuminates as soon as a malfunction occurs.

#### 6. DTC CLEAR CONDITION

- When the OK idling cycle is completed 40 times in a row
- When "Clear Memory" is performed

#### 7. MALFUNCTION INDICATOR LIGHT CLEAR CONDITION

- When the OK driving cycle is completed 3 times in a row
- When "Clear Memory" is performed

# Diagnostic Trouble Code (DTC) Detecting Criteria

GENERAL DESCRIPTION

---

## 8. FAIL SAFE

- Air flow meter: Engine load is normally calculated by manifold pressure and engine speed; however, calculated only by manifold pressure.
- EVAP conc. learning (fuel): Not allowed to learn.
- Knock compensation:
  - Knock compensation final advance/delay angle value = knock compensation value + whole learning compensation value + portional learning compensation value
  - When normal: Knock compensation value = Fixed at 0°C.A.
  - Failure: Knock compensation value ≠ Fixed at 0°C.A. (When knock: Max. 12°C.A retard)
  - Whole learning compensation coefficient update not allowed.
  - Portional learning zone compensation value calculation not allowed.
- ISC control: Open loop compensation is set to (1 g/s). Stop calculation of throttle sensor temperature compensation. (Hold the previous value.)
- Purge control: Not allowed to purge.

## 9. ECM OPERATION AT DTC SETTING

Memorize the freeze frame data. (For test mode \$02)

# Diagnostic Trouble Code (DTC) Detecting Criteria

## GENERAL DESCRIPTION

### M: DTC P0103 MASS OR VOLUME AIR FLOW CIRCUIT HIGH INPUT

#### 1. OUTLINE OF DIAGNOSIS

Detect open or short circuits of the air flow sensor.  
Judge as NG if it is out of specification.

#### 2. COMPONENT DESCRIPTION

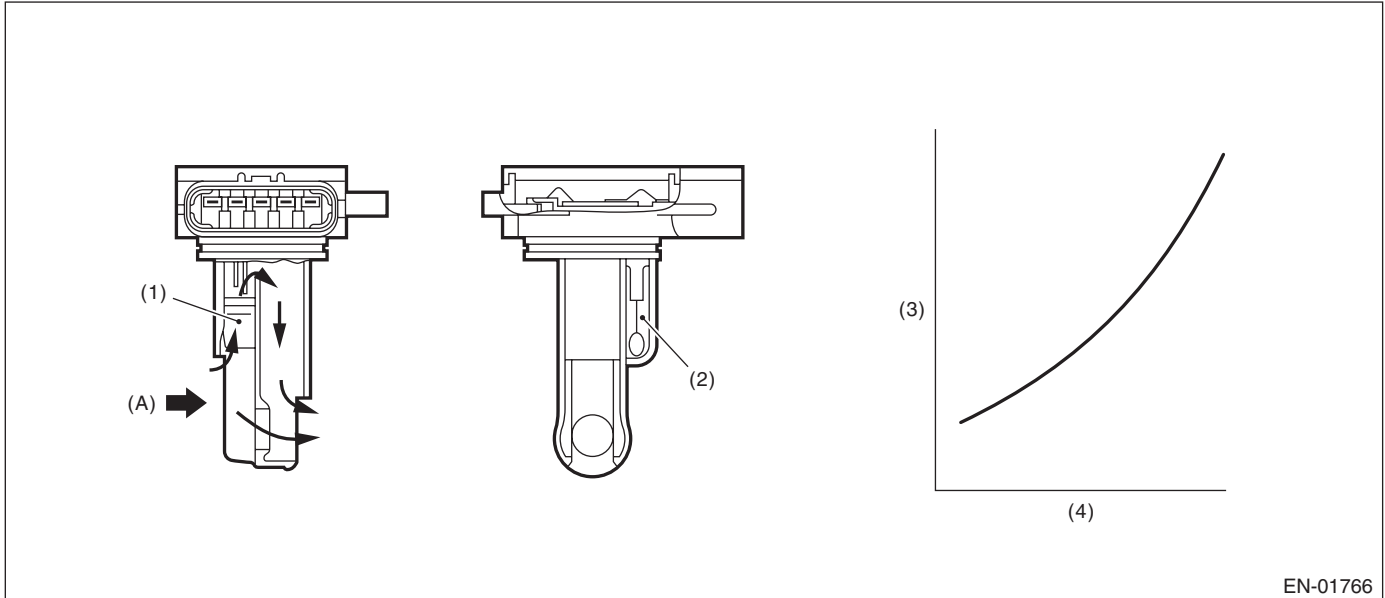

(1) Air flow sensor

(2) Intake air temperature sensor

(3) Voltage (V)

(4) Intake air volume (kg/s)

(A) Air

EN-01766

#### 3. ENABLE CONDITION

Secondary Parameters	Enable Conditions
None	

#### 4. GENERAL DRIVING CYCLE

Always perform the diagnosis continuously.

#### 5. DIAGNOSTIC METHOD

Judge as NG when the continuous time of the following base value is higher than 0.5 seconds. Judge as OK and clear the NG when the malfunction criteria below are not met.

##### Judgment Value

Malfunction Criteria	Threshold Value
Output voltage	$\geq 4.985$ V

**Time Needed for Diagnosis:** 0.5 seconds

**Malfunction Indicator Light Illumination:** Illuminates as soon as a malfunction occurs.

#### 6. DTC CLEAR CONDITION

- When the OK idling cycle is completed 40 times in a row
- When "Clear Memory" is performed

#### 7. MALFUNCTION INDICATOR LIGHT CLEAR CONDITION

- When the OK driving cycle is completed 3 times in a row
- When "Clear Memory" is performed

# Diagnostic Trouble Code (DTC) Detecting Criteria

GENERAL DESCRIPTION

---

## 8. FAIL SAFE

- Air flow meter: Engine load is normally calculated by manifold pressure and engine speed; however, calculated only by manifold pressure.
- EVAP conc. learning (fuel): Not allowed to learn.
- Knock compensation:
  - Knock compensation final advance/delay angle value = knock compensation value + whole learning compensation value + portional learning compensation value
  - When normal: Knock compensation value = Fixed at 0°C.A.
  - Failure: Knock compensation value ≠ Fixed at 0°C.A. (When knock: Max. 12°C.A retard)
  - Whole learning compensation coefficient update not allowed.
  - Portional learning zone compensation value calculation not allowed.
- ISC control: Open loop compensation is set to (1 g/s). Stop calculation of throttle sensor temperature compensation. (Hold the previous value.)
- Purge control: Not allowed to purge.

## 9. ECM OPERATION AT DTC SETTING

Memorize the freeze frame data. (For test mode \$02)

# Diagnostic Trouble Code (DTC) Detecting Criteria

## GENERAL DESCRIPTION

### N: DTC P0107 MANIFOLD ABSOLUTE PRESSURE/BAROMETRIC PRESSURE CIRCUIT LOW INPUT

#### 1. OUTLINE OF DIAGNOSIS

Detect the open or short circuit of intake manifold pressure sensor.

Judge as NG if it is out of specification.

#### 2. COMPONENT DESCRIPTION

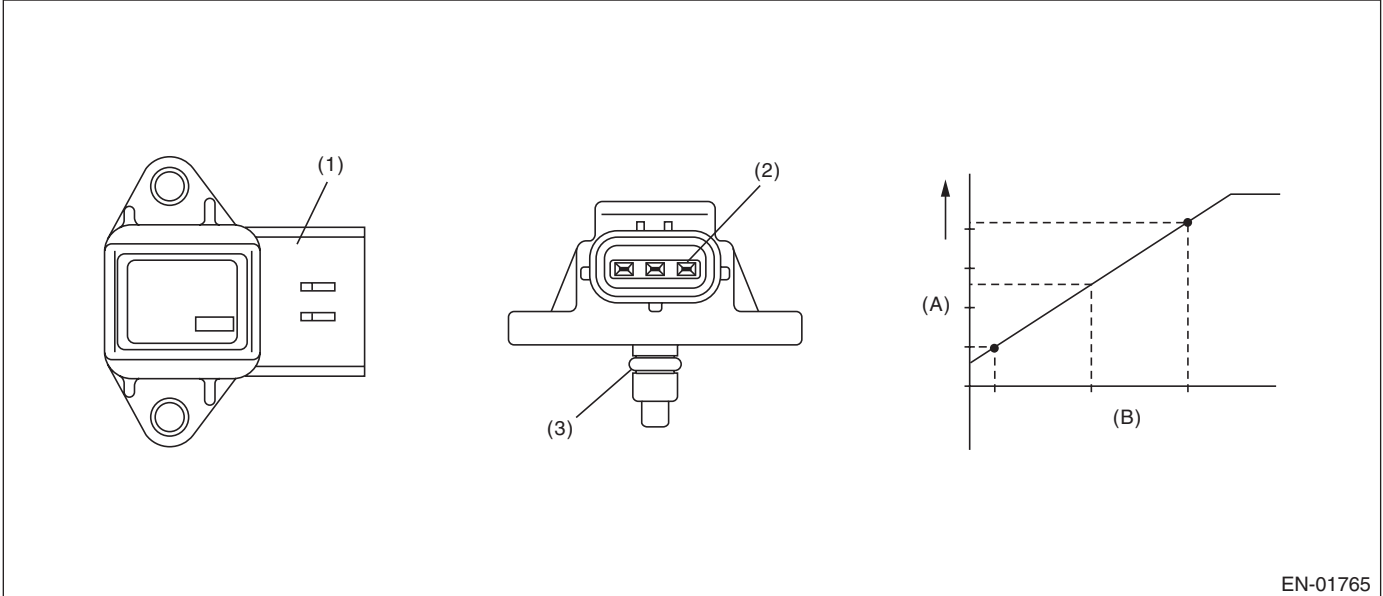

- (1) Connector
- (2) Terminal
- (3) O-ring

- (A) Output voltage
- (B) Absolute pressure

EN-01765

#### 3. ENABLE CONDITION

Secondary Parameters	Enable Conditions
Battery voltage	$\geq 10.9 \text{ V}$

#### 4. GENERAL DRIVING CYCLE

Always perform the diagnosis continuously.

#### 5. DIAGNOSTIC METHOD

Judge as NG when the continuous time of meeting the malfunction criteria below becomes 0.5 seconds or more. Judge as OK and clear the NG when the malfunction criteria below are not met.

##### Judgment Value

Malfunction Criteria	Threshold Value
Output voltage	$< 0.568 \text{ V}$

**Time Needed for Diagnosis:** 0.5 seconds

**Malfunction Indicator Light Illumination:** Illuminates as soon as a malfunction occurs.

#### 6. DTC CLEAR CONDITION

- When the OK idling cycle is completed 40 times in a row
- When "Clear Memory" is performed

#### 7. MALFUNCTION INDICATOR LIGHT CLEAR CONDITION

- When the OK driving cycle is completed 3 times in a row
- When "Clear Memory" is performed



# Diagnostic Trouble Code (DTC) Detecting Criteria

GENERAL DESCRIPTION

---

## 8. FAIL SAFE

- Intake manifold pressure sensor process: Estimate the pressure from engine load.
- ISC feedback: Not allowed to calculate the amount of feedback.
- Heavy fuel judgment: Not allowed to carry out the heavy judgment.
- Fuel cut control: Not allowed to cut the over pressure charged fuel.

## 9. ECM OPERATION AT DTC SETTING

Memorize the freeze frame data. (For test mode \$02)

# Diagnostic Trouble Code (DTC) Detecting Criteria

## GENERAL DESCRIPTION

### O: DTC P0108 MANIFOLD ABSOLUTE PRESSURE/BAROMETRIC PRESSURE CIRCUIT HIGH INPUT

#### 1. OUTLINE OF DIAGNOSIS

Detect the open or short circuit of intake manifold pressure sensor.

Judge as NG if it is out of specification.

#### 2. COMPONENT DESCRIPTION

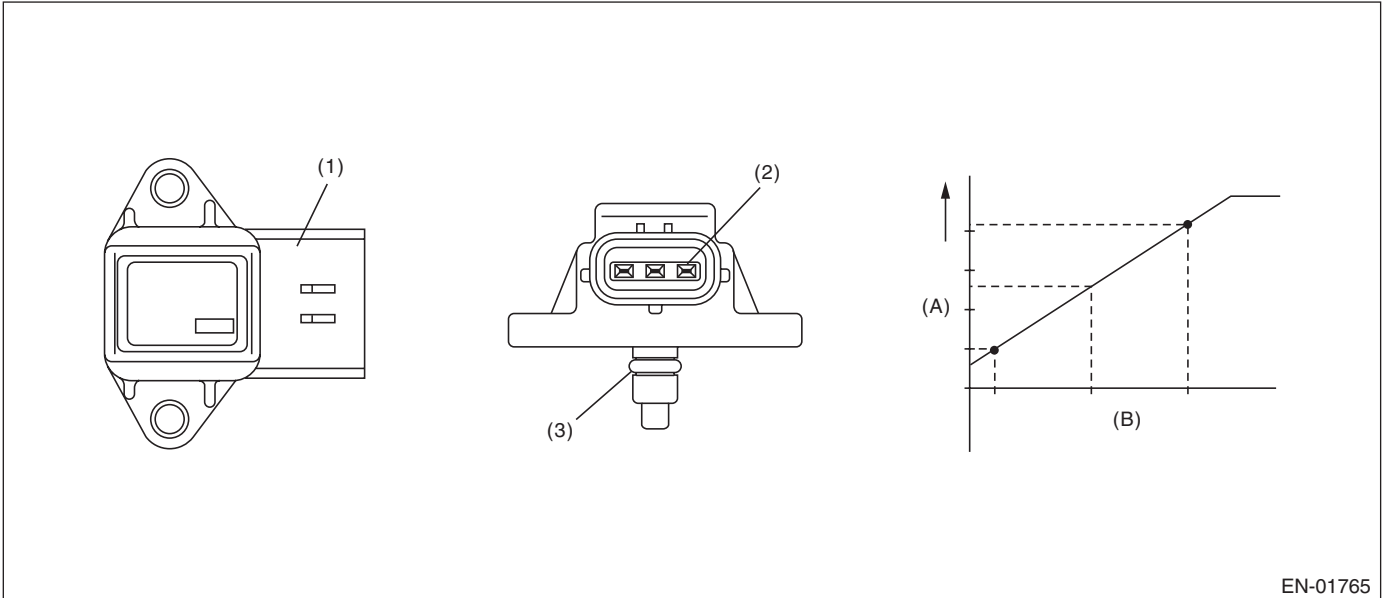

- (1) Connector
- (2) Terminal
- (3) O-ring

- (A) Output voltage
- (B) Absolute pressure

EN-01765

#### 3. ENABLE CONDITION

Secondary Parameters	Enable Conditions
Battery voltage	$\geq 10.9$ V

#### 4. GENERAL DRIVING CYCLE

Always perform the diagnosis continuously.

#### 5. DIAGNOSTIC METHOD

Judge as NG when the continuous time of meeting the malfunction criteria below becomes 0.5 seconds or more. Judge as OK and clear the NG when the malfunction criteria below are not met.

##### Judgment Value

Malfunction Criteria	Threshold Value
Output voltage	$\geq 4.93$ V

**Time Needed for Diagnosis:** 0.5 seconds

**Malfunction Indicator Light Illumination:** Illuminates as soon as a malfunction occurs.

#### 6. DTC CLEAR CONDITION

- When the OK idling cycle is completed 40 times in a row
- When "Clear Memory" is performed

#### 7. MALFUNCTION INDICATOR LIGHT CLEAR CONDITION

- When the OK driving cycle is completed 3 times in a row
- When "Clear Memory" is performed

# Diagnostic Trouble Code (DTC) Detecting Criteria

GENERAL DESCRIPTION

---

## 8. FAIL SAFE

- Intake manifold pressure sensor process: Estimate the pressure from engine load.
- ISC feedback: Not allowed to calculate the amount of feedback.
- Heavy fuel judgment: Not allowed to carry out the heavy judgment.
- Fuel cut control: Not allowed to cut the over pressure charged fuel.

## 9. ECM OPERATION AT DTC SETTING

Memorize the freeze frame data. (For test mode \$02)

# Diagnostic Trouble Code (DTC) Detecting Criteria

## GENERAL DESCRIPTION

### P: DTC P0111 INTAKE AIR TEMPERATURE SENSOR 1 CIRCUIT RANGE/ PERFORMANCE

#### 1. OUTLINE OF DIAGNOSIS

Detect the malfunction of intake air temperature sensor output property.

Judge as NG when the intake air temperature is not varied whereas it seemed to be varied from the viewpoint of engine condition.

#### 2. COMPONENT DESCRIPTION

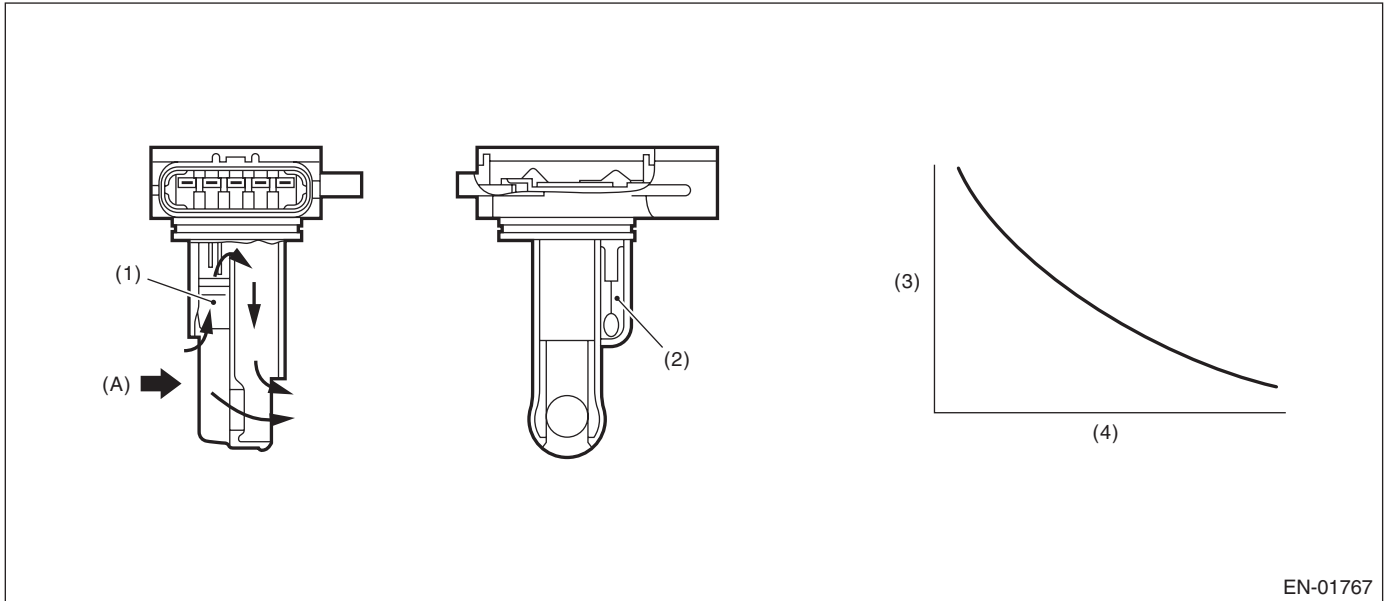

EN-01767

(1) Air flow sensor

(A) Air

(2) Intake air temperature sensor

(3) Resistance value ( $\Omega$ )

(4) Intake air temperature °C (°F)

#### 3. ENABLE CONDITION

Secondary Parameters	Enable Conditions
Coolant temp. before engine start	< 30°C (86°F)
Engine coolant temperature	> 95°C (203°F)
Battery voltage	≥ 10.9 V
Continuous time when the vehicle speed is less than 50 km/h (31 MPH)	600 seconds or more

#### 4. GENERAL DRIVING CYCLE

Perform the diagnosis when the vehicle speed condition is completed after idling from starting the cooled engine.

# Diagnostic Trouble Code (DTC) Detecting Criteria

GENERAL DESCRIPTION

## 5. DIAGNOSTIC METHOD

### Abnormality Judgment

Judge as NG when the continuous time of meeting the malfunction criteria below becomes 1 second or more.

### Judgment Value

Malfunction Criteria	Threshold Value
Output voltage difference between Max. and Min.	< 20 mV (Equivalent to approximately 0.5°C (33°F) near 25°C)

**Time Needed for Diagnosis:** 1 second

**Malfunction Indicator Light Illumination:** Illuminates when malfunction occurs in 2 continuous driving cycles.

### Normality Judgment

Judge as OK and clear the NG when the malfunction criteria below are met.

### Judgment Value

Malfunction Criteria	Threshold Value
Output voltage difference between Max. and Min.	≥ 20 mV

## 6. DTC CLEAR CONDITION

- When the OK idling cycle is completed 40 times in a row
- When "Clear Memory" is performed

## 7. MALFUNCTION INDICATOR LIGHT CLEAR CONDITION

- When the OK driving cycle is completed 3 times in a row
- When "Clear Memory" is performed

## 8. FAIL SAFE

Intake air temperature sensor process: Intake air temperature is fixed at 20°C (68°F).

## 9. ECM OPERATION AT DTC SETTING

Memorize the freeze frame data. (For test mode \$02)

# Diagnostic Trouble Code (DTC) Detecting Criteria

## GENERAL DESCRIPTION

### Q: DTC P0112 INTAKE AIR TEMPERATURE SENSOR 1 CIRCUIT LOW

#### 1. OUTLINE OF DIAGNOSIS

Detect open or short circuit of the intake air temperature sensor.  
Judge as NG if it is out of specification.

#### 2. COMPONENT DESCRIPTION

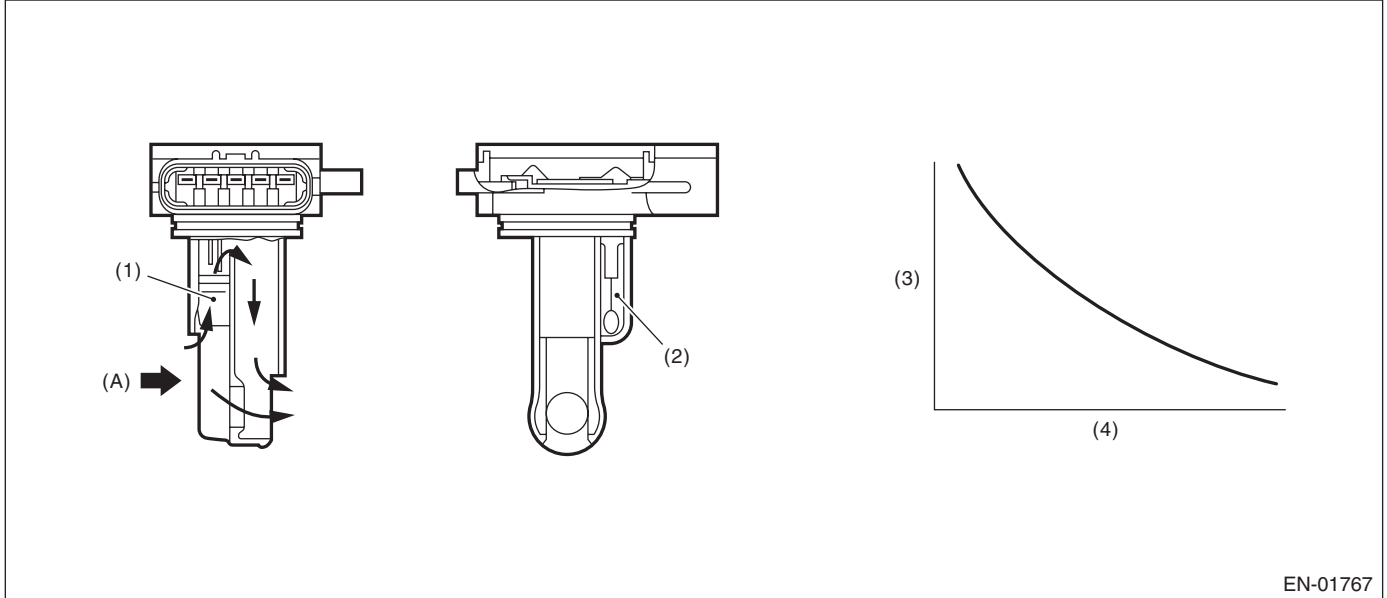

(1) Air flow sensor

(2) Intake air temperature sensor

(3) Resistance value ( $\Omega$ )

(4) Intake air temperature °C (°F)

(A) Air

EN-01767

#### 3. ENABLE CONDITION

Secondary Parameters	Enable Conditions
None	

#### 4. GENERAL DRIVING CYCLE

Always perform the diagnosis continuously.

# Diagnostic Trouble Code (DTC) Detecting Criteria

GENERAL DESCRIPTION

## 5. DIAGNOSTIC METHOD

### Abnormality Judgment

Judge as NG when the continuous time of meeting the malfunction criteria below becomes 0.5 seconds or more.

### Judgment Value

Malfunction Criteria	Threshold Value
Output voltage	< 0.165 V
Ignition switch	ON

**Time Needed for Diagnosis:** 0.5 seconds

**Malfunction Indicator Light Illumination:** Illuminates as soon as a malfunction occurs.

### Normality Judgment

Judge as OK and clear the NG when the malfunction criteria below are met.

### Judgment Value

Malfunction Criteria	Threshold Value
Output voltage	$\geq 0.165$ V
Ignition switch	ON

## 6. DTC CLEAR CONDITION

- When the OK idling cycle is completed 40 times in a row
- When "Clear Memory" is performed

## 7. MALFUNCTION INDICATOR LIGHT CLEAR CONDITION

- When the OK driving cycle is completed 3 times in a row
- When "Clear Memory" is performed

## 8. FAIL SAFE

Intake air temperature sensor process: Intake air temperature is fixed at 20°C (68°F).

## 9. ECM OPERATION AT DTC SETTING

Memorize the freeze frame data. (For test mode \$02)

# Diagnostic Trouble Code (DTC) Detecting Criteria

## GENERAL DESCRIPTION

### R: DTC P0113 INTAKE AIR TEMPERATURE SENSOR 1 CIRCUIT HIGH

#### 1. OUTLINE OF DIAGNOSIS

Detect open or short circuit of the intake air temperature sensor.  
Judge as NG if it is out of specification.

#### 2. COMPONENT DESCRIPTION

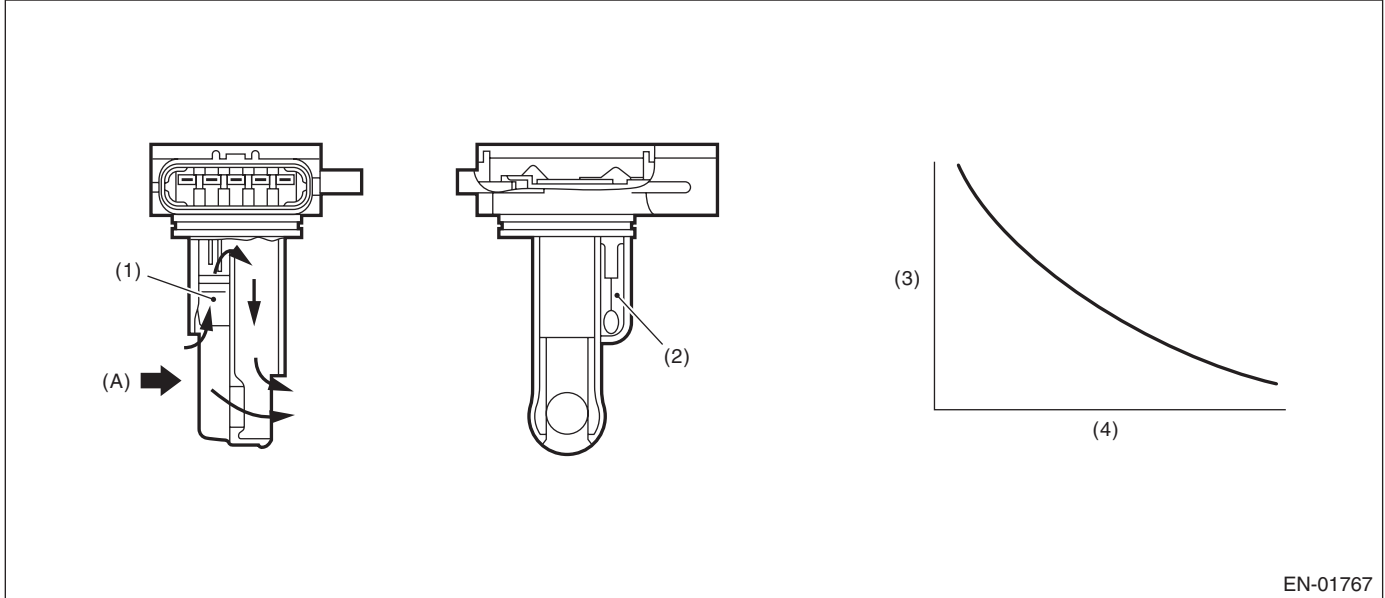

(1) Air flow sensor

(2) Intake air temperature sensor

(3) Resistance value ( $\Omega$ )

(4) Intake air temperature °C (°F)

(A) Air

EN-01767

#### 3. ENABLE CONDITION

Secondary Parameters	Enable Conditions
None	

#### 4. GENERAL DRIVING CYCLE

Always perform the diagnosis continuously.



# Diagnostic Trouble Code (DTC) Detecting Criteria

GENERAL DESCRIPTION

## 5. DIAGNOSTIC METHOD

### Abnormality Judgment

Judge as NG when the continuous time of meeting the malfunction criteria below becomes 0.5 seconds or more.

### Judgment Value

Malfunction Criteria	Threshold Value
Output voltage	$\geq 4.72$ V
Ignition switch	ON

**Time Needed for Diagnosis:** 0.5 seconds

**Malfunction Indicator Light Illumination:** Illuminates as soon as a malfunction occurs.

### Normality Judgment

Judge as OK and clear the NG when the malfunction criteria below are met.

### Judgment Value

Malfunction Criteria	Threshold Value
Output voltage	$\geq 0.23$ V
Ignition switch	ON

## 6. DTC CLEAR CONDITION

- When the OK idling cycle is completed 40 times in a row
- When "Clear Memory" is performed

## 7. MALFUNCTION INDICATOR LIGHT CLEAR CONDITION

- When the OK driving cycle is completed 3 times in a row
- When "Clear Memory" is performed

## 8. FAIL SAFE

Intake air temperature sensor process: Intake air temperature is fixed at 20°C (68°F).

## 9. ECM OPERATION AT DTC SETTING

Memorize the freeze frame data. (For test mode \$02)

# Diagnostic Trouble Code (DTC) Detecting Criteria

## GENERAL DESCRIPTION

### S: DTC P0117 ENGINE COOLANT TEMPERATURE CIRCUIT LOW

#### 1. OUTLINE OF DIAGNOSIS

Detect the open or short circuit of the engine coolant temperature sensor.  
Judge as NG if it is out of specification.

#### 2. COMPONENT DESCRIPTION

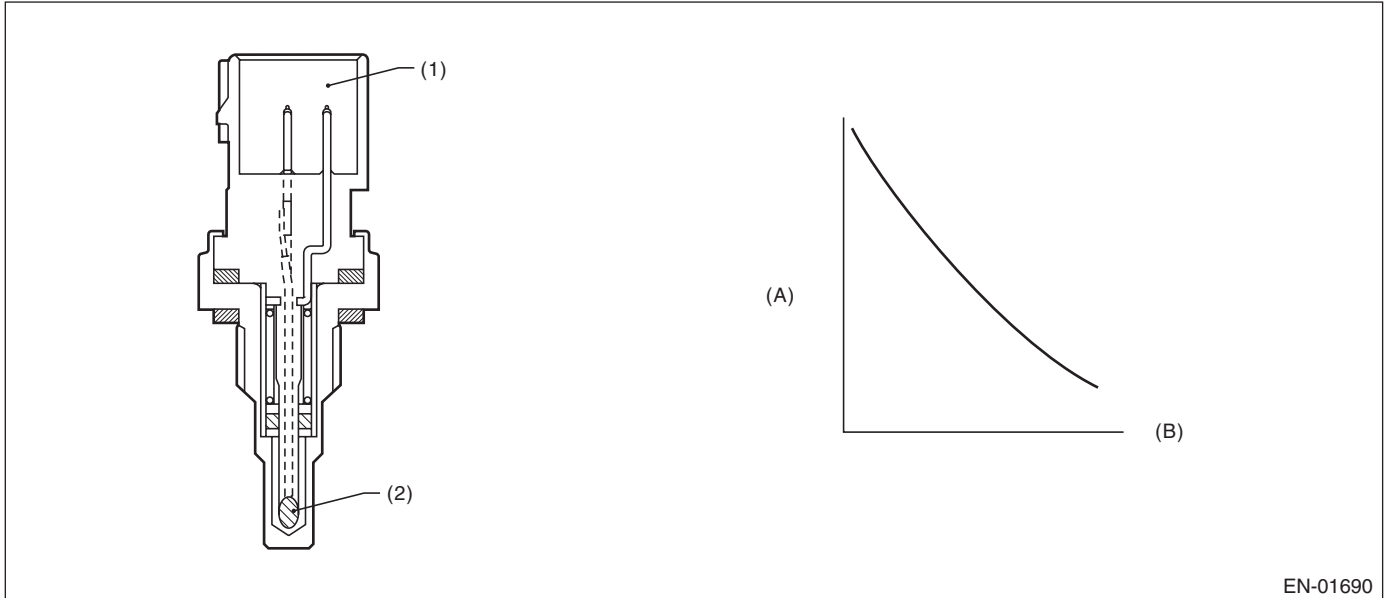

- (1) Connector
- (2) Thermistor element

- (A) Resistance value (k $\Omega$ )
- (B) Temperature °C (°F)

EN-01690

#### 3. ENABLE CONDITION

Secondary Parameters	Enable Conditions
None	

#### 4. GENERAL DRIVING CYCLE

Always perform the diagnosis continuously.

#### 5. DIAGNOSTIC METHOD

Judge as NG when the continuous time of meeting the malfunction criteria below becomes 0.5 seconds or more. Judge as OK and clear the NG when the malfunction criteria below are not met.

##### Judgment Value

Malfunction Criteria	Threshold Value
Output voltage	< 0.165 V

**Time Needed for Diagnosis:** 0.5 seconds

**Malfunction Indicator Light Illumination:** Illuminates as soon as a malfunction occurs.

#### 6. DTC CLEAR CONDITION

- When the OK idling cycle is completed 40 times in a row
- When "Clear Memory" is performed

#### 7. MALFUNCTION INDICATOR LIGHT CLEAR CONDITION

- When the OK driving cycle is completed 3 times in a row
- When "Clear Memory" is performed

# Diagnostic Trouble Code (DTC) Detecting Criteria

GENERAL DESCRIPTION

---

## 8. FAIL SAFE

- Engine coolant temperature sensor process: Engine coolant temperature is fixed at 70°C (158°F)
- ISC Feedback: Calculate target engine speed as engine coolant temperature 70°C (158°F).
- ISC learning: Not allowed to learn.
- Heavy fuel judgment control: Not allowed to carry out the heavy judgment.
- Air conditioner control: Not allowed to turn the air conditioner to ON.
- Radiator fan control: Both main and sub fan are in High driving.
- High water temperature expansion compensation coefficient: Normally, mass expands with high water temperature and other conditions, but this ignores water temperature conditions and expands when other conditions are established.
- AVCS Control: Oil flow control solenoid valve drive output duty = 0 %.
- Tumble generator valve control: Open the tumble generator valve.

## 9. ECM OPERATION AT DTC SETTING

Memorize the freeze frame data. (For test mode \$02)

# Diagnostic Trouble Code (DTC) Detecting Criteria

## GENERAL DESCRIPTION

### T: DTC P0118 ENGINE COOLANT TEMPERATURE CIRCUIT HIGH

#### 1. OUTLINE OF DIAGNOSIS

Detect the open or short circuit of the engine coolant temperature sensor.  
Judge as NG if it is out of specification.

#### 2. COMPONENT DESCRIPTION

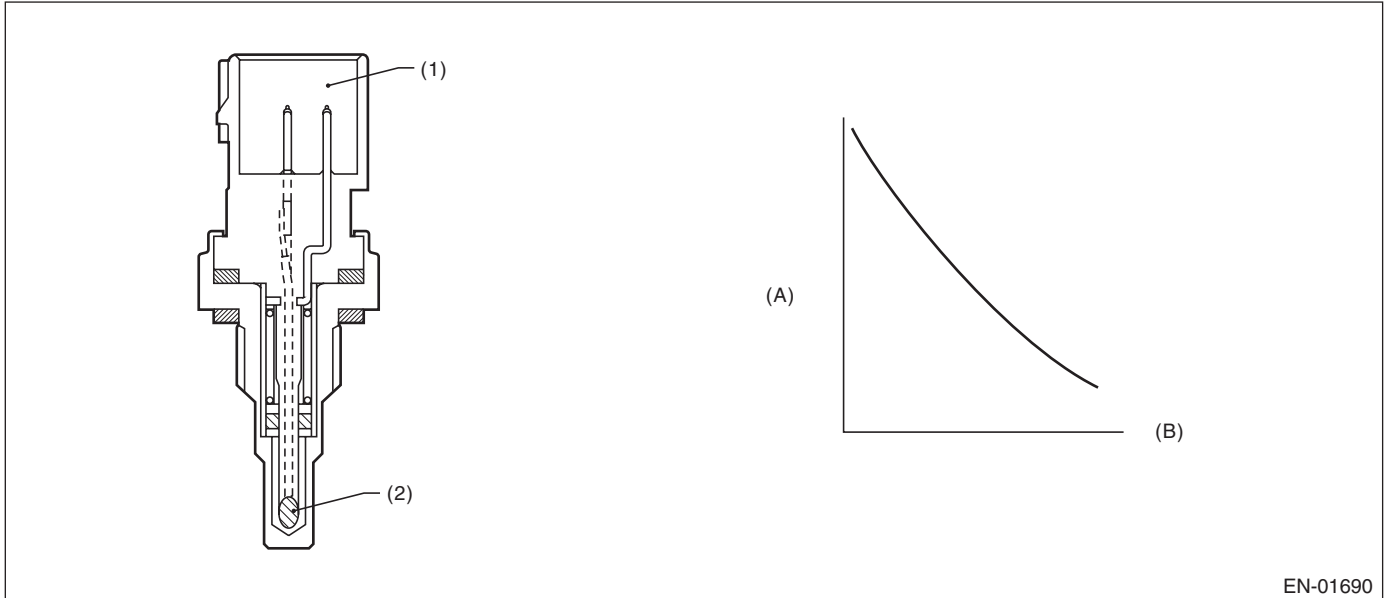

- (1) Connector  
(2) Thermistor element

- (A) Resistance value (k $\Omega$ )  
(B) Temperature °C (°F)

EN-01690

#### 3. ENABLE CONDITION

Secondary Parameters	Enable Conditions
None	

#### 4. GENERAL DRIVING CYCLE

Always perform the diagnosis continuously.

#### 5. DIAGNOSTIC METHOD

Judge as NG when the continuous time of meeting the malfunction criteria below becomes 0.5 seconds or more. Judge as OK and clear the NG when the malfunction criteria below are not met.

##### Judgment Value

Malfunction Criteria	Threshold Value
Output voltage	$\geq 4.72$ V

**Time Needed for Diagnosis:** 0.5 seconds

**Malfunction Indicator Light Illumination:** Illuminates as soon as a malfunction occurs.

#### 6. DTC CLEAR CONDITION

- When the OK idling cycle is completed 40 times in a row
- When "Clear Memory" is performed

#### 7. MALFUNCTION INDICATOR LIGHT CLEAR CONDITION

- When the OK driving cycle is completed 3 times in a row
- When "Clear Memory" is performed

# Diagnostic Trouble Code (DTC) Detecting Criteria

GENERAL DESCRIPTION

---

## 8. FAIL SAFE

- Engine coolant temperature sensor process: Engine coolant temperature is fixed at 70°C (158°F)
- ISC Feedback: Calculate target engine speed as engine coolant temperature 70°C (158°F).
- ISC learning: Not allowed to learn.
- Heavy fuel judgment control: Not allowed to carry out the heavy judgment.
- Air conditioner control: Not allowed to turn the air conditioner to ON.
- Radiator fan control: Both main and sub fan are in High driving.
- High water temperature expansion compensation coefficient: Normally, mass expands with high water temperature and other conditions, but this ignores water temperature conditions and expands when other conditions are established.
- AVCS Control: Oil flow control solenoid valve drive output duty = 0 %.
- Tumble generator valve control: Open the tumble generator valve.

## 9. ECM OPERATION AT DTC SETTING

Memorize the freeze frame data. (For test mode \$02)

# Diagnostic Trouble Code (DTC) Detecting Criteria

## GENERAL DESCRIPTION

### U: DTC P0122 THROTTLE/PEDAL POSITION SENSOR/SWITCH “A” CIRCUIT LOW

#### 1. OUTLINE OF DIAGNOSIS

Detect the open or short circuit of throttle position sensor 1.  
Judge as NG if it is out of specification.

#### 2. COMPONENT DESCRIPTION

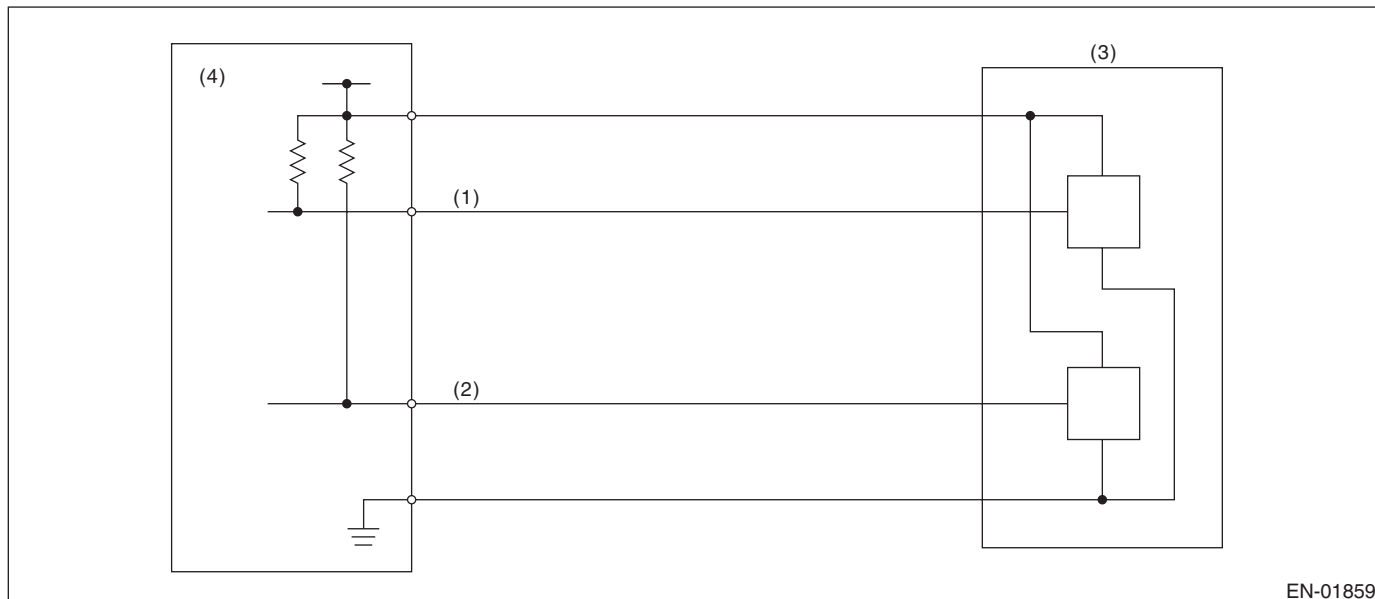

- (1) Throttle position sensor 1 signal
- (2) Throttle position sensor 2 signal
- (3) Throttle position sensor
- (4) Engine control module (ECM)

#### 3. ENABLE CONDITION

Secondary Parameters	Enable Conditions
Ignition switch	ON

#### 4. GENERAL DRIVING CYCLE

Always perform the diagnosis continuously.

#### 5. DIAGNOSTIC METHOD

Judge as OK and clear the NG when the malfunction criteria below are met.

##### Judgment Value

Malfunction Criteria	Threshold Value
Sensor 1 input voltage	$\leq 0.224$ V

**Time Needed for Diagnosis:** 24 milliseconds

**Malfunction Indicator Light Illumination:** Illuminates as soon as a malfunction occurs.

#### 6. DTC CLEAR CONDITION

- When the OK idling cycle is completed 40 times in a row
- When “Clear Memory” is performed (Only with engine stopped)

#### 7. MALFUNCTION INDICATOR LIGHT CLEAR CONDITION

- When the OK driving cycle is completed 3 times in a row
- When “Clear Memory” is performed (Only with engine stopped)

## Diagnostic Trouble Code (DTC) Detecting Criteria

GENERAL DESCRIPTION

---

### **8. FAIL SAFE**

Stop the continuity to the electronic throttle control motor. (Throttle opening is fixed to 6°.)

### **9. ECM OPERATION AT DTC SETTING**

Memorize the freeze frame data. (For test mode \$02)

# Diagnostic Trouble Code (DTC) Detecting Criteria

## GENERAL DESCRIPTION

### V: DTC P0123 THROTTLE/PEDAL POSITION SENSOR/SWITCH “A” CIRCUIT HIGH

#### 1. OUTLINE OF DIAGNOSIS

Detect the open or short circuit of throttle position sensor 1.

Judge as NG if it is out of specification.

#### 2. COMPONENT DESCRIPTION

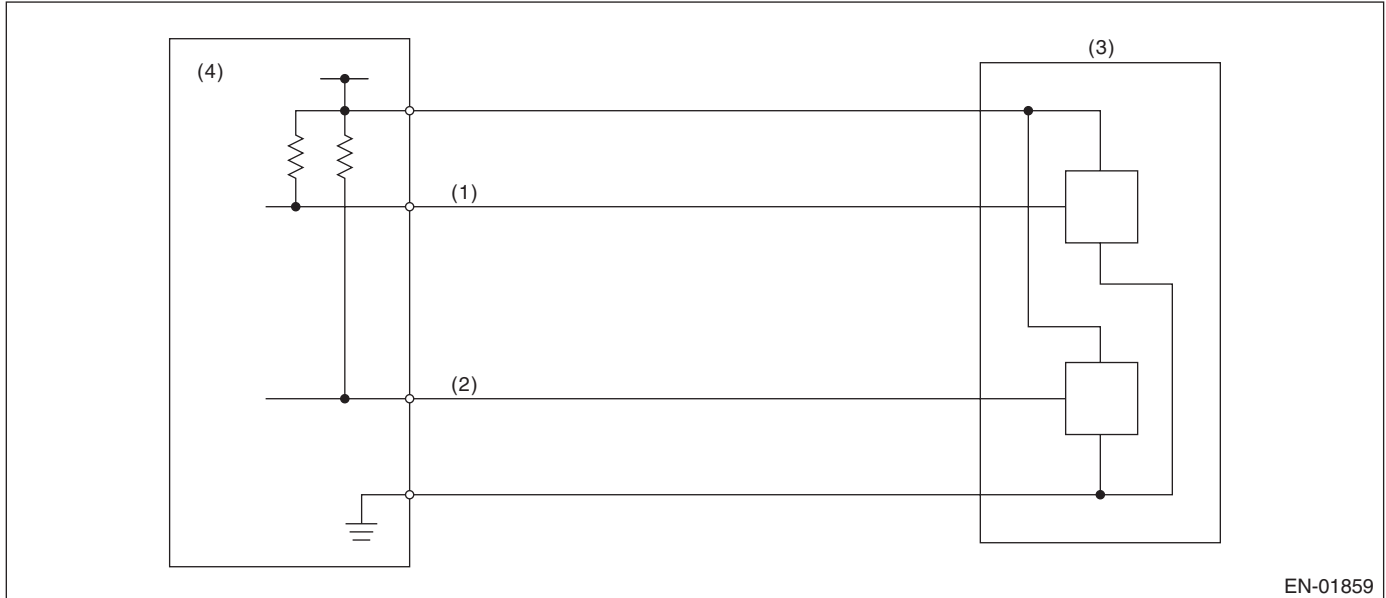

- (1) Throttle position sensor 1 signal
- (2) Throttle position sensor 2 signal
- (3) Throttle position sensor
- (4) Engine control module (ECM)

#### 3. ENABLE CONDITION

Secondary Parameters	Enable Conditions
Ignition switch	ON

#### 4. GENERAL DRIVING CYCLE

Always perform the diagnosis continuously.

#### 5. DIAGNOSTIC METHOD

Judge as OK and clear the NG when the malfunction criteria below are met.

##### Judgment Value

Malfunction Criteria	Threshold Value
Sensor 1 input voltage	$\geq 4.851$ V

**Time Needed for Diagnosis:** 24 milliseconds

**Malfunction Indicator Light Illumination:** Illuminates as soon as a malfunction occurs.

#### 6. DTC CLEAR CONDITION

- When the OK idling cycle is completed 40 times in a row
- When “Clear Memory” is performed (Only with engine stopped)

#### 7. MALFUNCTION INDICATOR LIGHT CLEAR CONDITION

- When the OK driving cycle is completed 3 times in a row
- When “Clear Memory” is performed (Only with engine stopped)



## Diagnostic Trouble Code (DTC) Detecting Criteria

GENERAL DESCRIPTION

---

### **8. FAIL SAFE**

Stop the continuity to the electronic throttle control motor. (Throttle opening is fixed to 6°.)

### **9. ECM OPERATION AT DTC SETTING**

Memorize the freeze frame data. (For test mode \$02)

# Diagnostic Trouble Code (DTC) Detecting Criteria

## GENERAL DESCRIPTION

### W: DTC P0125 INSUFFICIENT COOLANT TEMPERATURE FOR CLOSED LOOP FUEL CONTROL

#### 1. OUTLINE OF DIAGNOSIS

Detect the malfunction of engine coolant temperature output property.

Judge as NG when the engine coolant temperature does not rise in driving conditions where it should.

#### 2. COMPONENT DESCRIPTION

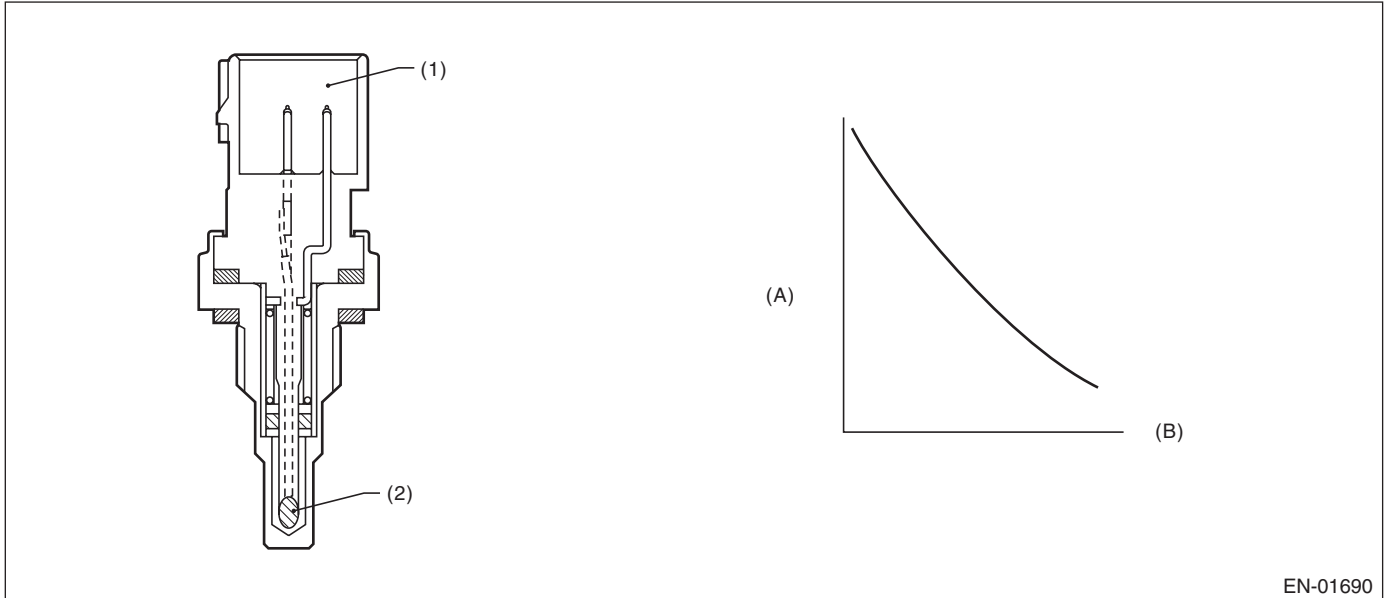

- (1) Connector
- (2) Thermistor element

- (A) Resistance value (k $\Omega$ )
- (B) Temperature °C (°F)

EN-01690

#### 3. ENABLE CONDITION

Secondary Parameters	Enable Conditions
Engine speed	$\geq 500$ rpm
Battery voltage	$> 10.9$ V

#### 4. GENERAL DRIVING CYCLE

Perform the diagnosis only once after engine starting.

#### 5. DIAGNOSTIC METHOD

##### Abnormality Judgment

Judge as NG when the malfunction criteria below are met.

##### Judgment Value

Malfunction Criteria	Threshold Value
Engine coolant temperature	$< 20^{\circ}\text{C}$ ( $68^{\circ}\text{F}$ )
Timer for diagnosis after engine starting	$\geq$ Judgment value of timer after engine starting

# Diagnostic Trouble Code (DTC) Detecting Criteria

GENERAL DESCRIPTION

Timer for diagnosis after engine starting

a. Timer stop at fuel cut mode

b. During the driving conditions except a) above, timer counts up.

64 milliseconds + TWCNT milliseconds (at the time of 64 milliseconds)

TWCNT is defined as follows.

TWCNT = 0 (at idle switch ON)

TWCNT show on the following table at idle switch OFF.

Temperature °C (°F)	Vehicle speed km/h (MPH)							
	0 (0)	8 (4.97)	16 (9.94)	24 (14.9)	32 (19.9)	40 (24.9)	48 (29.8)	56 (34.8)
-20 (-4)	0 ms	37.14 ms	74.27 ms	111.41 ms	126.66 ms	141.91 ms	163.59 ms	185.26 ms
-10 (14)	0 ms	27.39 ms	54.78 ms	82.17 ms	99.65 ms	117.13 ms	135.96 ms	154.80 ms
0 (32)	0 ms	17.65 ms	35.29 ms	52.94 ms	72.64 ms	92.34 ms	108.34 ms	124.33 ms
10 (50)	0 ms	7.90 ms	15.80 ms	23.70 ms	45.63 ms	67.56 ms	80.71 ms	93.87 ms
20 (68)	0 ms	7.90 ms	15.80 ms	23.70 ms	45.63 ms	67.56 ms	80.71 ms	93.87 ms

Judgment value of timer after engine starting

$$t = 451.1 - 25.9 \times T_i$$

T<sub>i</sub> = The lowest engine coolant temperature after starting the engine

**Time Needed for Diagnosis:** To be determined. (It is varied by the Min. engine coolant temperature and engine conditions such as vehicle speed and engine coolant temperature.)

**Malfunction Indicator Light Illumination:** Illuminates when malfunction occurs in 2 continuous driving cycles.

## Normality Judgment

Judge as OK and clear the NG when the malfunction criteria below are met.

## Judgment Value

Malfunction Criteria	Threshold Value
Engine coolant temperature	≥ 20°C (68°F)

## 6. DTC CLEAR CONDITION

- When the OK idling cycle is completed 40 times in a row
- When "Clear Memory" is performed

## 7. MALFUNCTION INDICATOR LIGHT CLEAR CONDITION

- When the OK driving cycle is completed 3 times in a row
- When "Clear Memory" is performed

## 8. FAIL SAFE

- Engine coolant temperature sensor process: Engine coolant temperature is fixed at 70°C (158°F)
- ISC Feedback: Calculate target engine speed as engine coolant temperature 70°C (158°F).
- ISC learning: Not allowed to learn.
- Heavy fuel judgment control: Not allowed to carry out the heavy judgment.
- Air conditioner control: Not allowed to turn the air conditioner to ON.
- Radiator fan control: Both main and sub fan are in High driving.
- High water temperature expansion compensation coefficient: Normally, mass expands with high water temperature and other conditions, but this ignores water temperature conditions and expands when other conditions are established.
- AVCS Control: Oil flow control solenoid valve drive output duty = 0 %.
- Tumble generator valve control: Open the tumble generator valve.

## 9. ECM OPERATION AT DTC SETTING

Memorize the freeze frame data. (For test mode \$02)

# Diagnostic Trouble Code (DTC) Detecting Criteria

## GENERAL DESCRIPTION

### X: DTC P0126 INSUFFICIENT ENGINE COOLANT TEMPERATURE FOR STABLE OPERATION

#### 1. OUTLINE OF DIAGNOSIS

Detect the malfunction of the engine coolant temperature sensor characteristics.

Memorize the engine coolant temperature and fuel temperature at the last engine stop, and use them to judge as NG when the engine coolant temperature does not decrease when it should.

#### 2. COMPONENT DESCRIPTION

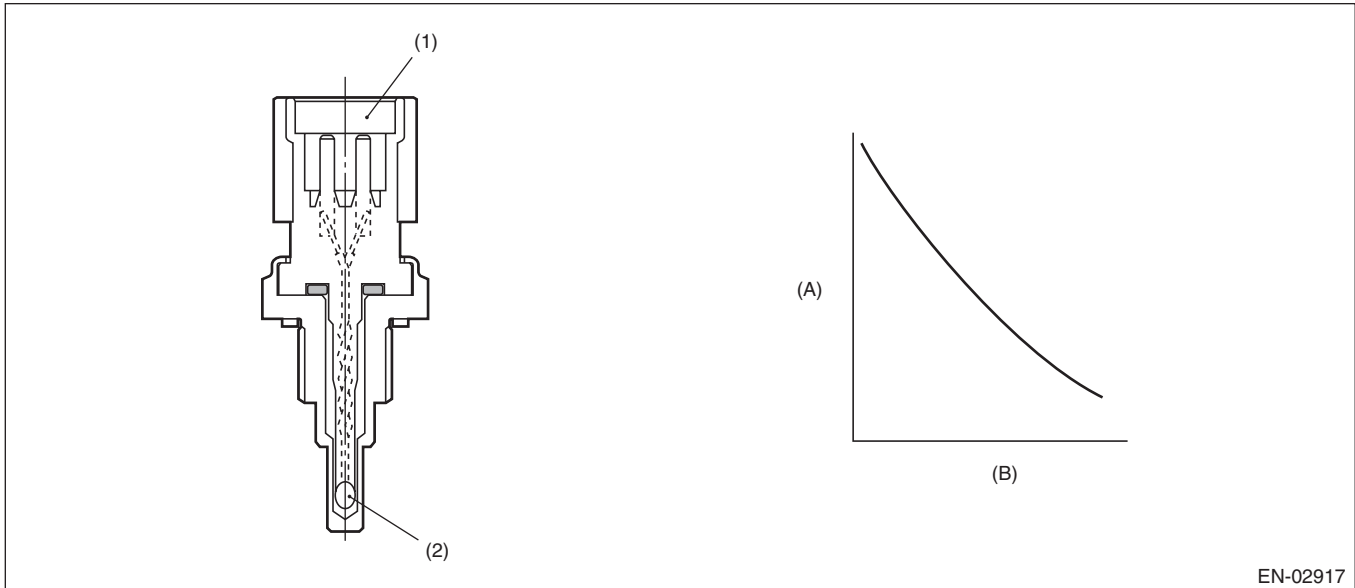

EN-02917

- (1) Connector
- (2) Thermistor element

- (A) Resistance value (k $\Omega$ )
- (B) Temperature °C (°F)

#### 3. ENABLE CONDITION

Secondary Parameters	Enable Conditions
Battery voltage	$\geq 10.9$ V
Refueling from the last engine stop till the current engine start	None
Fuel level	$\geq 15$ $\ell$ (3.96 US gal, 3.3 Imp gal)
Engine coolant temperature at the last engine stop	$\geq 70^{\circ}\text{C}$ (158°F) and $< 95^{\circ}\text{C}$ (203°F)

#### 4. GENERAL DRIVING CYCLE

Perform the diagnosis only once after starting the engine.

# Diagnostic Trouble Code (DTC) Detecting Criteria

GENERAL DESCRIPTION

## 5. DIAGNOSTIC METHOD

### Abnormality Judgment

Judge as NG if the continuous time with the following conditions established is more than 2.5 seconds.

### Judgment Value

Malfunction Criteria	Threshold Value
Engine coolant temperature at the last engine stop — Minimum engine coolant temperature after the engine start	< 2.5°C (4.5°F)
Fuel temperature at the last engine stop — fuel temperature	≥ 5°C (9°F)
Intake air temperature — fuel temperature	< 2.5°C (4.5°F)
Fuel temperature	< 35°C (95°F)

### Normality Judgment

When the following conditions are established, it is OK.

### Judgment Value

Malfunction Criteria	Threshold Value
Engine coolant temperature at the last engine stop — Minimum engine coolant temperature after the engine start	≥ 2.5°C (4.5°F)

**Time Needed for Diagnosis:** 2.5 seconds

**Malfunction Indicator Light Illumination:** Illuminates when malfunction occurs in 2 continuous driving cycles.

## 6. DTC CLEAR CONDITION

- When the OK idling cycle is completed 40 times in a row
- When “Clear Memory” is performed

## 7. MALFUNCTION INDICATOR LIGHT CLEAR CONDITION

- When the OK driving cycle is completed 3 times in a row
- When “Clear Memory” is performed

## 8. FAIL SAFE

None

## 9. ECM OPERATION AT DTC SETTING

Memorize the freeze frame data. (For test mode \$02)

# Diagnostic Trouble Code (DTC) Detecting Criteria

## GENERAL DESCRIPTION

### Y: DTC P0128 COOLANT THERMOSTAT (ENGINE COOLANT TEMPERATURE BELOW THERMOSTAT REGULATING TEMPERATURE)

#### 1. OUTLINE OF DIAGNOSIS

Detect malfunctions of the thermostat function.

Judge as NG when the engine coolant temperature is lower than the estimated engine coolant temperature and the difference between them is large. Judge as OK when the engine coolant temperature becomes to 75°C (167°F), and the difference is small, before judging NG.

#### 2. COMPONENT DESCRIPTION

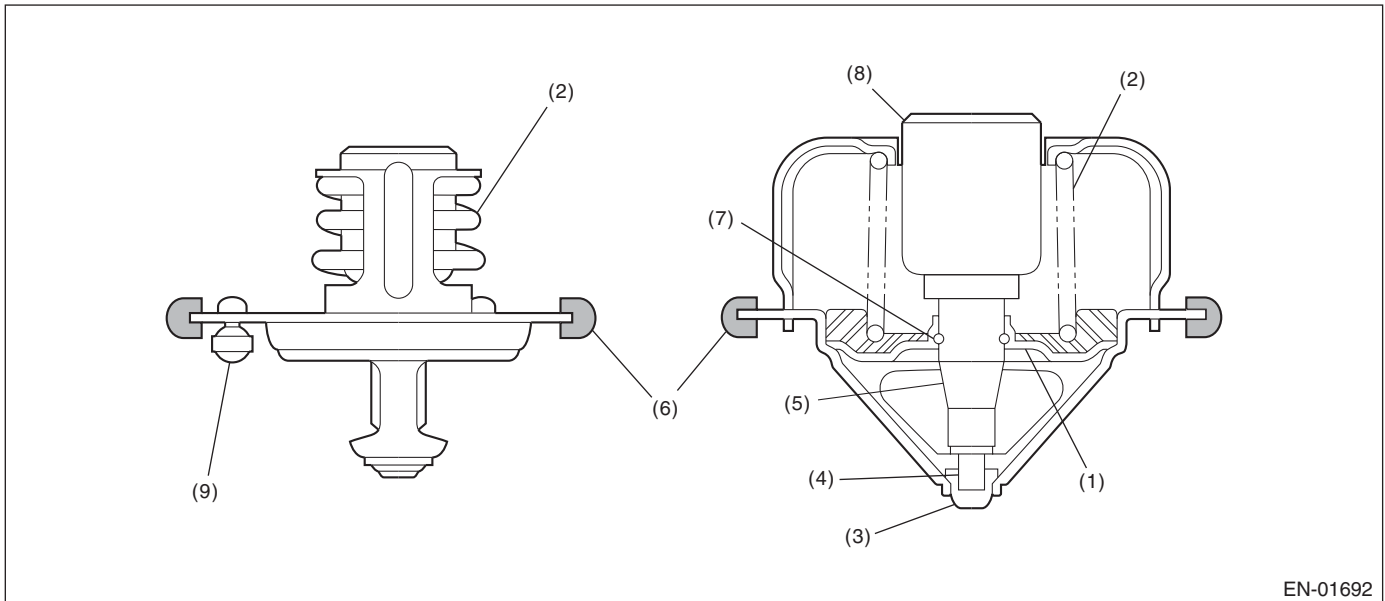

- (1) Valve
- (2) Spring
- (3) Stopper
- (4) Piston
- (5) Guide

- (6) Rubber packing
- (7) Stop ring
- (8) Wax element
- (9) Jiggle valve

#### 3. ENABLE CONDITION

Secondary Parameters	Enable Conditions
None	

#### 4. GENERAL DRIVING CYCLE

Always perform the diagnosis continuously.

# Diagnostic Trouble Code (DTC) Detecting Criteria

GENERAL DESCRIPTION

## 5. DIAGNOSTIC METHOD

### Abnormality Judgment

Judge as NG when the continuous time of meeting the malfunction criteria below becomes 30 seconds or more.

### Judgment Value

Malfunction Criteria	Threshold Value
Battery voltage	$\geq 10.9$ V
Estimate ambient temperature	$\geq -7^{\circ}\text{C}$ (19.4°F)
Engine coolant temperature at engine starting	$< 55^{\circ}\text{C}$ (131°F)
Estimated coolant temperature	$\geq 70^{\circ}\text{C}$ (158°F)
Engine coolant temperature	$< 70^{\circ}\text{C}$ (158°F)
(Estimated - Measured) Engine coolant temperature	$> 30^{\circ}\text{C}$ (54°F)
Vehicle speed	$\geq 30$ km/h

**Time Needed for Diagnosis:** 30 seconds

**Malfunction Indicator Light Illumination:** Illuminates when malfunction occurs in 2 continuous driving cycles.

### Normality Judgment

Judge as OK and clear the NG when the malfunction criteria below are met.

### Judgment Value

Malfunction Criteria	Threshold Value
Battery voltage	$\geq 10.9$ V
Estimate ambient temperature	$\geq -7^{\circ}\text{C}$ (19.4°F)
Thermostat malfunction diagnosis	Incomplete
Engine coolant temperature at engine starting	$< 55^{\circ}\text{C}$ (131°F)
Engine coolant temperature	$\geq 70^{\circ}\text{C}$ (158°F)
(Estimated - Measured) Engine coolant temperature	$\leq 30^{\circ}\text{C}$ (54°F)

## 6. DTC CLEAR CONDITION

- When the OK idling cycle is completed 40 times in a row
- When "Clear Memory" is performed

## 7. MALFUNCTION INDICATOR LIGHT CLEAR CONDITION

- When the OK driving cycle is completed 3 times in a row
- When "Clear Memory" is performed

## 8. FAIL SAFE

None

## 9. ECM OPERATION AT DTC SETTING

Memorize the freeze frame data. (For test mode \$02)

# Diagnostic Trouble Code (DTC) Detecting Criteria

## GENERAL DESCRIPTION

### Z: DTC P0131 O2 SENSOR CIRCUIT LOW VOLTAGE (BANK 1 SENSOR 1)

#### 1. OUTLINE OF DIAGNOSIS

Detect the open or short circuit of sensor.

Judge as NG when the element impressed voltage is out of range, or the element current is out of range.

#### 2. COMPONENT DESCRIPTION

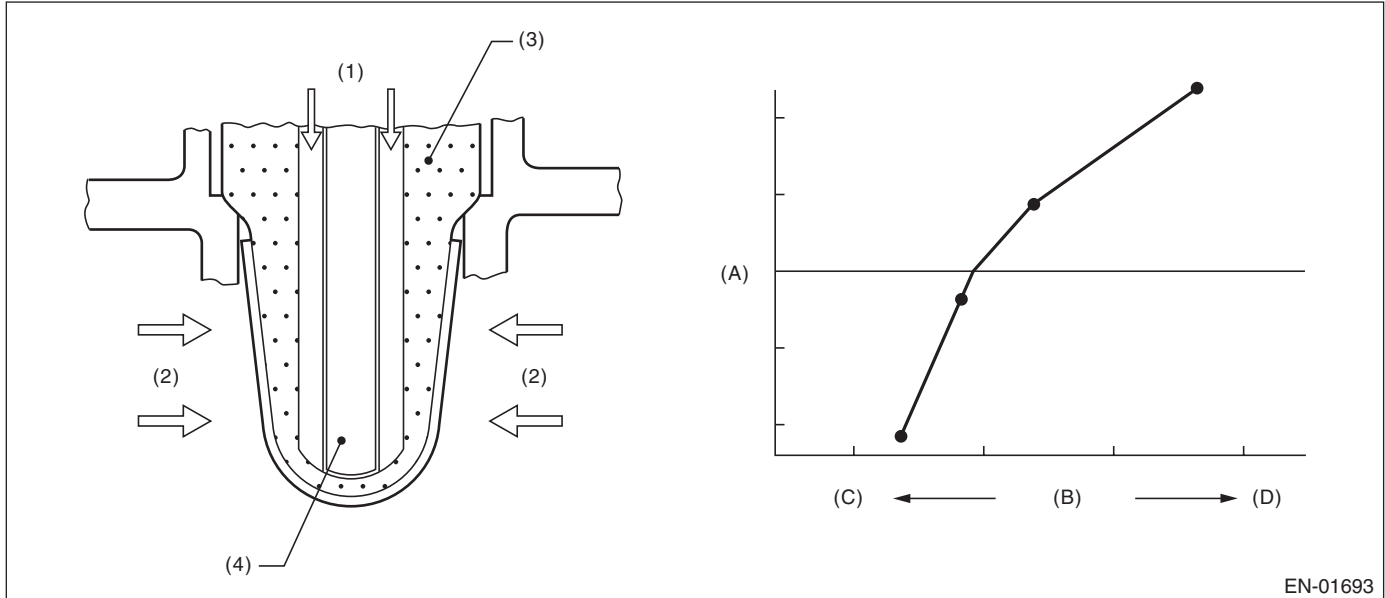

- (1) Atmosphere
- (2) Exhaust gas
- (3) ZrO<sub>2</sub>
- (4) Ceramic heater

- (A) Electromotive force
- (B) Air fuel ratio
- (C) Lean
- (D) Rich

#### 3. ENABLE CONDITION

Secondary Parameters	Enable Conditions
Voltage	≥ 10.9 V

#### 4. GENERAL DRIVING CYCLE

Always perform the diagnosis continuously.

#### 5. DIAGNOSTIC METHOD

Judge as NG when the continuous time of meeting any malfunction criteria below is more than 1 second.

##### Judgment Value

Malfunction Criteria	Threshold Value
Input voltage	< 1.8 V
Input current	< -0.01 A

**Time Needed for Diagnosis:** 1 second

**Malfunction Indicator Light Illumination:** Illuminates as soon as a malfunction occurs.

#### 6. DTC CLEAR CONDITION

- When the OK idling cycle is completed 40 times in a row
- When "Clear Memory" is performed

#### 7. MALFUNCTION INDICATOR LIGHT CLEAR CONDITION

- When the OK driving cycle is completed 3 times in a row
- When "Clear Memory" is performed



# Diagnostic Trouble Code (DTC) Detecting Criteria

GENERAL DESCRIPTION

---

## 8. FAIL SAFE

- Front oxygen (A/F) sensor activation judgment: Front oxygen (A/F) sensor full activation is not complete, or front oxygen (A/F) sensor half activation is not complete.
- A/F main learning: Not allowed to calculate the A/F main learning compensation factor.
- Compensation when starting the engine at high temperature: Make the MIN value to be 0.3 → 0, normally.
- Purge control: Not allowed to purge.

## 9. ECM OPERATION AT DTC SETTING

Memorize the freeze frame data. (For test mode \$02)

# Diagnostic Trouble Code (DTC) Detecting Criteria

## GENERAL DESCRIPTION

### AA:DTC P0132 O2 SENSOR CIRCUIT HIGH VOLTAGE (BANK 1 SENSOR 1)

#### 1. OUTLINE OF DIAGNOSIS

Detect the open or short circuit of sensor.

Judge as NG when the element impressed voltage is out of range, or the element current is out of range.

#### 2. COMPONENT DESCRIPTION

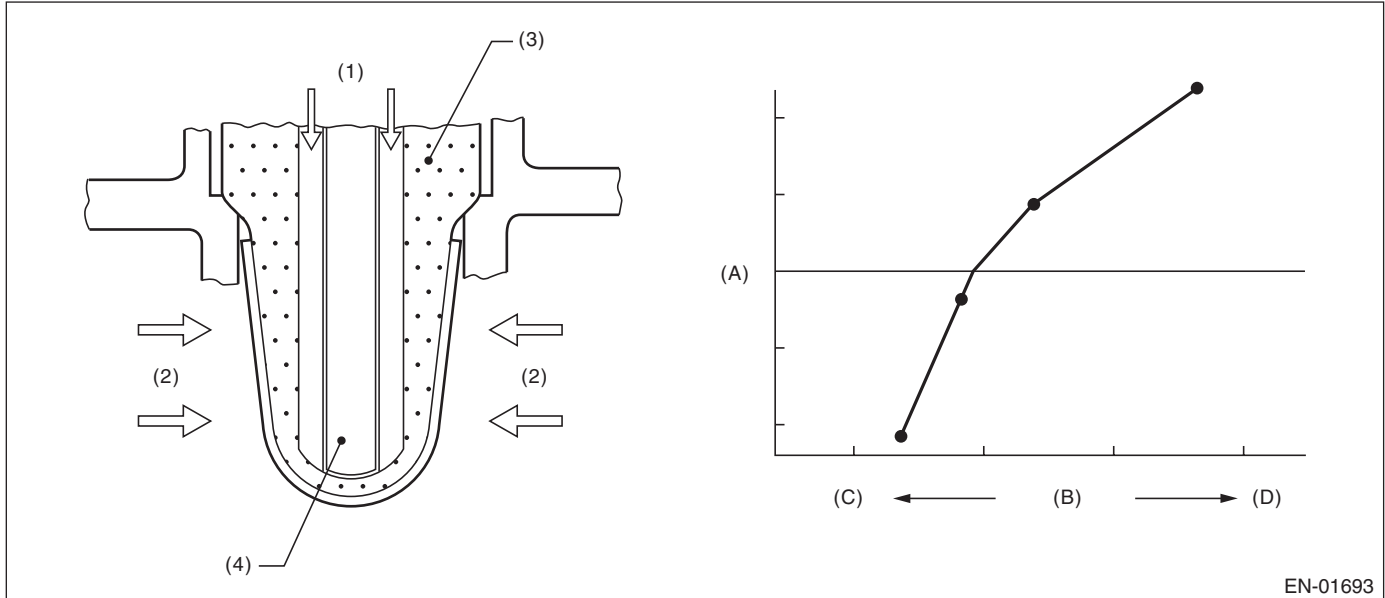

- (1) Atmosphere
- (2) Exhaust gas
- (3) ZrO<sub>2</sub>
- (4) Ceramic heater

- (A) Electromotive force
- (B) Air fuel ratio
- (C) Lean
- (D) Rich

#### 3. ENABLE CONDITION

Secondary Parameters	Enable Conditions
Voltage	≥ 10.9 V

#### 4. GENERAL DRIVING CYCLE

Always perform the diagnosis continuously.

#### 5. DIAGNOSTIC METHOD

Judge as NG when the continuous time of meeting any malfunction criteria below is more than 1 second.

##### Judgment Value

Malfunction Criteria	Threshold Value
Input voltage	≥ 3.8 V
Input current	≥ 0.01 A

**Time Needed for Diagnosis:** 1 second

**Malfunction Indicator Light Illumination:** Illuminates as soon as a malfunction occurs.

#### 6. DTC CLEAR CONDITION

- When the OK idling cycle is completed 40 times in a row
- When "Clear Memory" is performed

#### 7. MALFUNCTION INDICATOR LIGHT CLEAR CONDITION

- When the OK driving cycle is completed 3 times in a row
- When "Clear Memory" is performed

# Diagnostic Trouble Code (DTC) Detecting Criteria

GENERAL DESCRIPTION

---

## 8. FAIL SAFE

- Front oxygen (A/F) sensor activation judgment: Front oxygen (A/F) sensor full activation is not complete, or front oxygen (A/F) sensor half activation is not complete.
- A/F main learning: Not allowed to calculate the A/F main learning compensation factor.
- Compensation when starting the engine at high temperature: Make the MIN value to be 0.3 → 0, normally.
- Purge control: Not allowed to purge.

## 9. ECM OPERATION AT DTC SETTING

Memorize the freeze frame data. (For test mode \$02)

# Diagnostic Trouble Code (DTC) Detecting Criteria

## GENERAL DESCRIPTION

### AB:DTC P0133 O2 SENSOR CIRCUIT SLOW RESPONSE (BANK 1 SENSOR 1)

#### 1. OUTLINE OF DIAGNOSIS

Detect the slow response of front oxygen (A/F) sensor.

Front oxygen (A/F) sensor cover has some ventilation holes for exhaust gas. Clogged ventilation holes are diagnosed.

When the holes are clogged, the A/F output variation becomes slow comparing with the actual A/F variation because oxygen which reaches the zirconia layer is insufficient. Therefore, if the sensor cover holes are clogged, the rich to lean judgment in the ECM is delayed when the change from rich to lean occurs.

Judge as NG when the actual movement in comparison to the ECM control amount is slow.

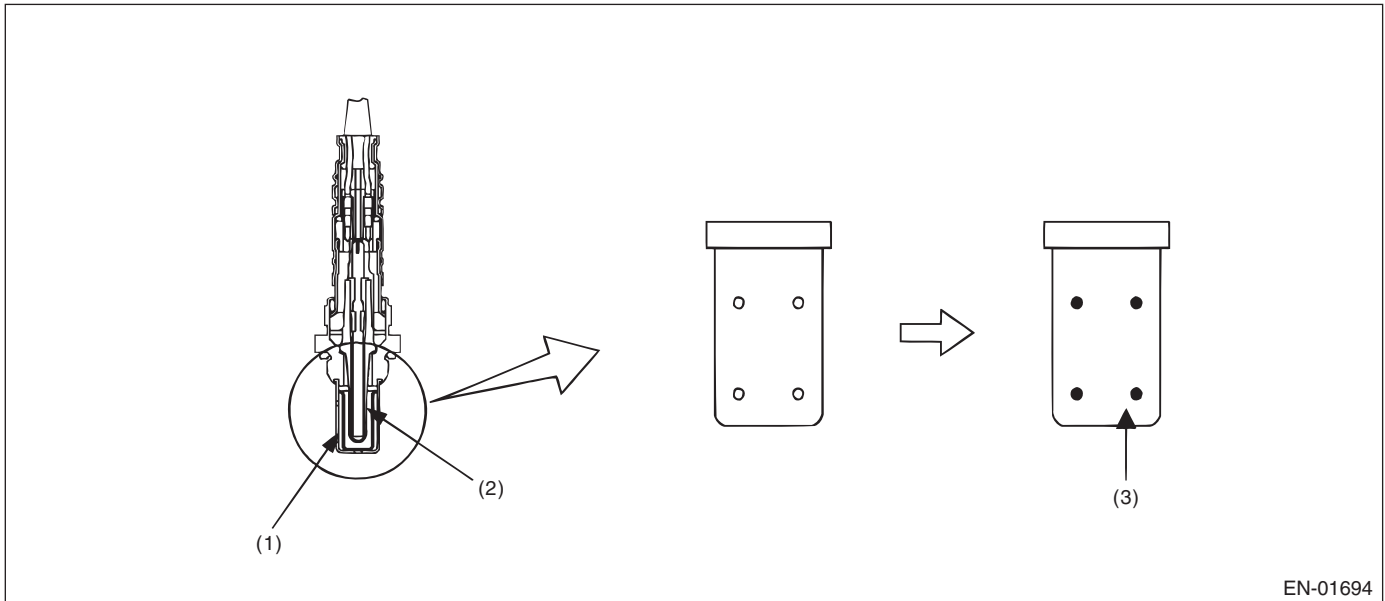

EN-01694

- (1) Cover
- (2) Zirconia
- (3) Clogging

# Diagnostic Trouble Code (DTC) Detecting Criteria

GENERAL DESCRIPTION

## 2. COMPONENT DESCRIPTION

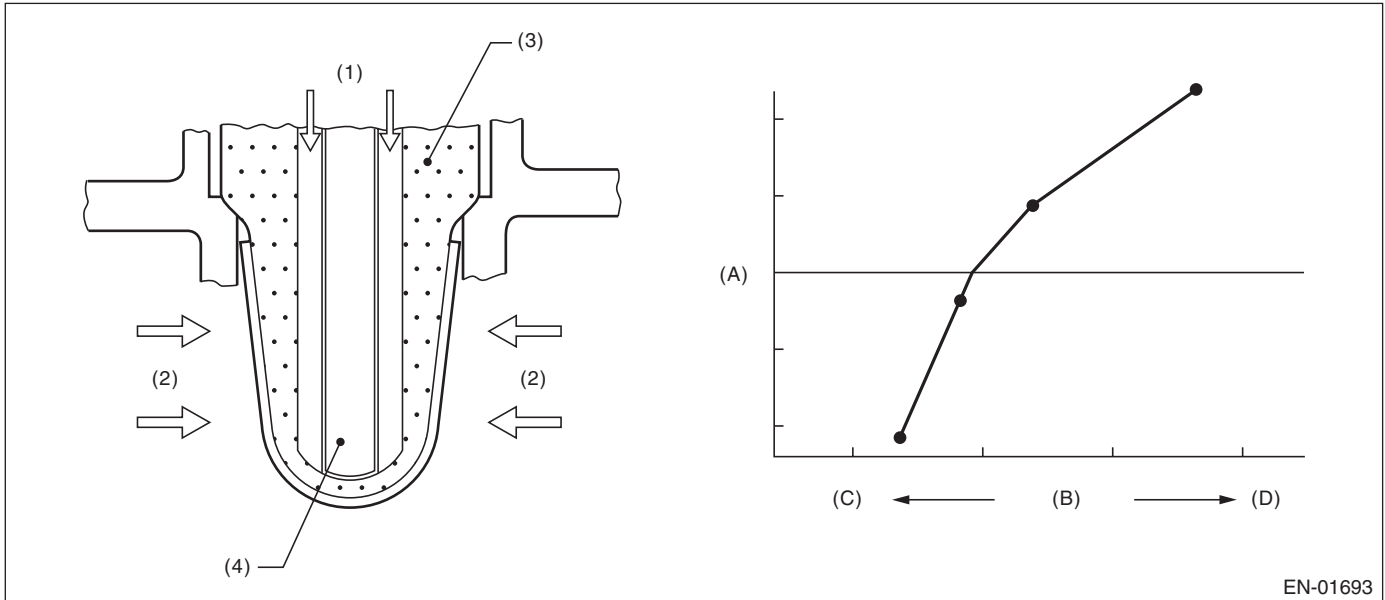

EN-01693

- (1) Atmosphere
- (2) Exhaust gas
- (3) ZrO<sub>2</sub>
- (4) Ceramic heater

- (A) Electromotive force
- (B) Air fuel ratio
- (C) Lean
- (D) Rich

## 3. ENABLE CONDITION

Secondary Parameters	Enable Conditions
All secondary parameters enable conditions	1 second or more
Battery voltage	> 10.9 V
Atmospheric pressure	> 75.0 kPa (563 mmHg, 22.2 inHg)
Closed loop control with main feedback	Operating
Front oxygen (A/F) sensor impedance	0 — 50 Ω
After engine starting	120 seconds or more
Engine coolant temperature	≥ 70°C (158°F)
Engine speed	1000 — 3200 rpm
Vehicle speed	10 — 120 km/h (6.21 — 74.6 MPH)
Amount of intake air	10 — 31 g/s
Engine load change during 0.5 engine revs.	≤ 0.02 g/rev
Learning value of EVAP conc. during purge	≤ 0.2
Total time of operating canister purge	20 seconds or more

## 4. GENERAL DRIVING CYCLE

Perform diagnosis only once, at a constant speed of 10 — 120 km/h (6.21 — 74.6 MPH) in 120 seconds or more after warming up the engine.

# Diagnostic Trouble Code (DTC) Detecting Criteria

## GENERAL DESCRIPTION

---

### 5. DIAGNOSTIC METHOD

Calculate  $\text{faf}$  difference every 128 milliseconds, and the  $\lambda$  value difference. Calculate the diagnosis value after calculating 1640 times (210 seconds).

Judge as NG when the malfunction criteria below are completed. Judge as OK and clear the NG when the malfunction criteria below are not met.

#### Judgment Value

Malfunction Criteria	Threshold Value
$\text{para} \text{fca} = \text{td}2 \text{faf} / \text{td}2 \text{lmd}$ where, $\text{td}2 \text{faf} (N) = \text{td}2 \text{faf} (n-1) +  \text{d}2 \text{faf} (n) $ $\text{td}2 \text{lmd} (N) = \text{td}2 \text{lmd} (n-1) +  \text{d}2 \text{lmd} (n) $ add up for a total of 210 seconds $\text{d}2 \text{faf} (n) = (\text{faf} (n) - \text{faf} (n-1)) - (\text{faf} (n-1) - \text{faf} (n-2))$ $\text{d}2 \text{lmd} (n) = (\text{lmd} (n) - \text{lmd} (n-1)) - (\text{lmd} (n-1) - \text{lmd} (n-2))$ $\text{faf}$ = main feedback compensation coefficient every 128 milliseconds $\text{lmd}$ = output lambda every 128 milliseconds	$\geq 0.392$

**Time Needed for Diagnosis:** 210 seconds

**Malfunction Indicator Light Illumination:** Illuminates when malfunction occurs in 2 continuous driving cycles.

### 6. DTC CLEAR CONDITION

- When the OK idling cycle is completed 40 times in a row
- When "Clear Memory" is performed

### 7. MALFUNCTION INDICATOR LIGHT CLEAR CONDITION

- When the OK driving cycle is completed 3 times in a row
- When "Clear Memory" is performed

### 8. FAIL SAFE

- Front oxygen (A/F) sensor main learning compensation: Not allowed to calculate.
- Correction when re-starting at high temperature: Normally minimum value  $0.3 \rightarrow 0$ .
- Purge control: Not allowed to purge.

### 9. ECM OPERATION AT DTC SETTING

- Memorize the freeze frame data. (For test mode \$02)
- Memorize the diagnostic value and trouble standard value. (For test mode \$06)

# Diagnostic Trouble Code (DTC) Detecting Criteria

GENERAL DESCRIPTION

## AC:DTC P0134 O2 SENSOR CIRCUIT NO ACTIVITY DETECTED (BANK 1 SENSOR 1)

### 1. OUTLINE OF DIAGNOSIS

Detect open circuits of the sensor.

Judge as NG when the impedance of the element is large.

### 2. COMPONENT DESCRIPTION

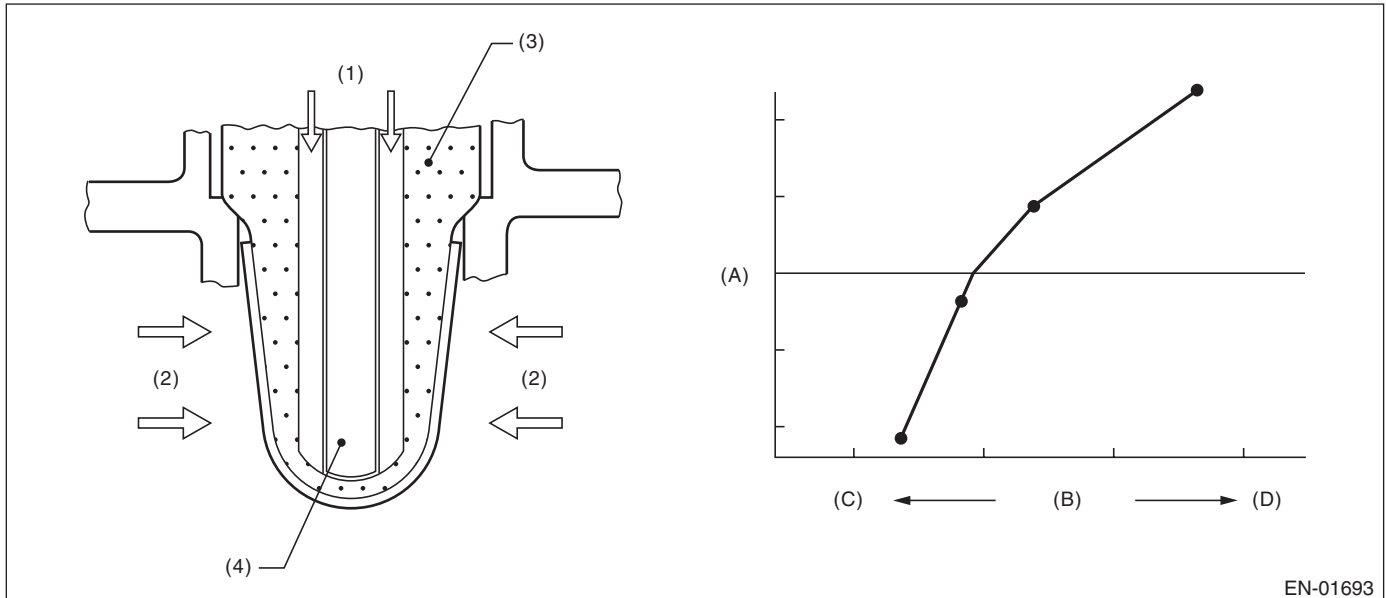

- (1) Atmosphere
- (2) Exhaust gas
- (3) ZrO<sub>2</sub>
- (4) Ceramic heater

- (A) Electromotive force
- (B) Air fuel ratio
- (C) Lean
- (D) Rich

### 3. ENABLE CONDITION

Secondary Parameters	Enable Conditions
None	

### 4. GENERAL DRIVING CYCLE

Always perform the diagnosis continuously.

### 5. DIAGNOSTIC METHOD

Judge as NG when the continuous time of meeting the malfunction criteria below becomes more than 5 seconds.

#### Judgment Value

Malfunction Criteria	Threshold Value
Voltage	≥ 10.9 V
Time after engine starting	≥ 50 sec.
Cumulative amount of the front lambda sensor heater control duty every 128 milliseconds.	≥ 28000%
Front oxygen (A/F) sensor impedance	≥ 500 Ω

**Time Needed for Diagnosis:** 5 seconds

**Malfunction Indicator Light Illumination:** Illuminates as soon as a malfunction occurs.

# Diagnostic Trouble Code (DTC) Detecting Criteria

## GENERAL DESCRIPTION

---

### 6. DTC CLEAR CONDITION

- When the OK idling cycle is completed 40 times in a row
- When "Clear Memory" is performed

### 7. MALFUNCTION INDICATOR LIGHT CLEAR CONDITION

- When the OK driving cycle is completed 3 times in a row
- When "Clear Memory" is performed

### 8. FAIL SAFE

- Front oxygen (A/F) sensor activation judgment: Front oxygen (A/F) sensor full activation is not complete, or front oxygen (A/F) sensor half activation is not complete.
- A/F main learning: Not allowed to calculate the A/F main learning compensation factor.
- Compensation when starting the engine at high temperature: Make the MIN value to be 0.3 → 0, normally.
- Purge control: Not allowed to purge.

### 9. ECM OPERATION AT DTC SETTING

Memorize the freeze frame data. (For test mode \$02)



# Diagnostic Trouble Code (DTC) Detecting Criteria

GENERAL DESCRIPTION

## AD:DTC P0137 O2 SENSOR CIRCUIT LOW VOLTAGE (BANK 1 SENSOR 2)

### 1. OUTLINE OF DIAGNOSIS

Detect the continuity NG of oxygen sensor. If the oxygen sensor voltage reading is not within the probable range considering the operating conditions, judge as NG.

### 2. COMPONENT DESCRIPTION

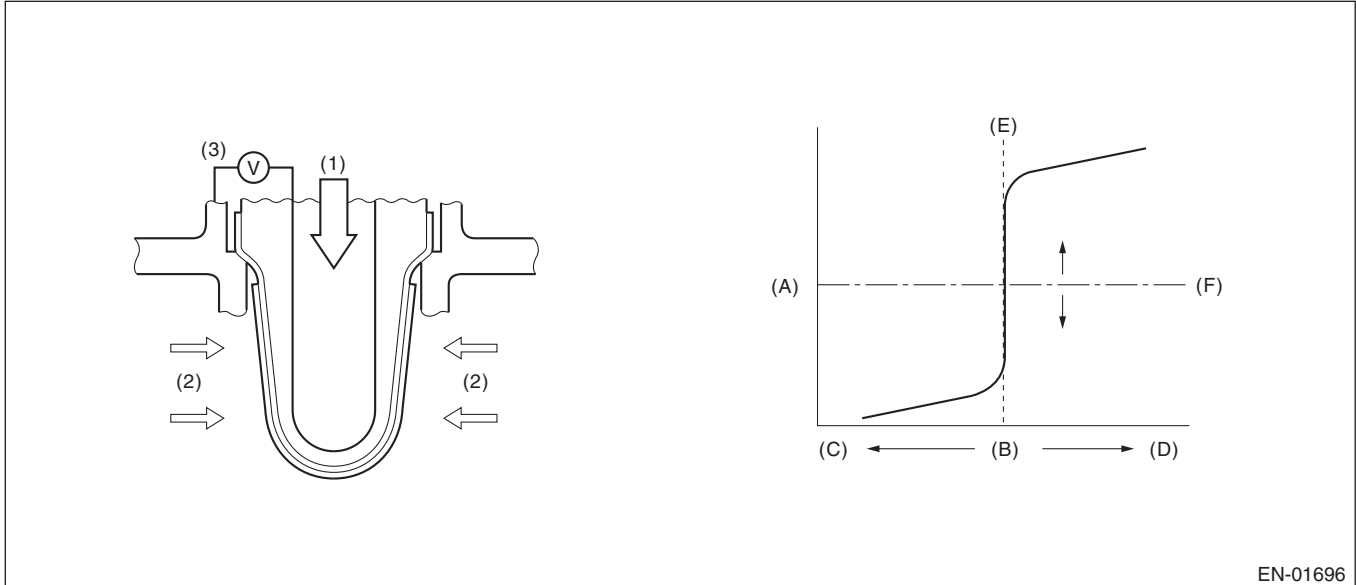

EN-01696

(A) Electromotive force

(B) Air fuel ratio

(1) Atmosphere

(C) Rich

(D) Lean

(2) Exhaust gas

(E) Theoretical air fuel ratio

(F) Comparative voltage

(3) Electromotive force

# Diagnostic Trouble Code (DTC) Detecting Criteria

## GENERAL DESCRIPTION

### 3. ENABLE CONDITION

#### Used only for abnormality judgment

Secondary Parameters	Enable Conditions
High side	
Secondary air injection system	Not in operation
Closed loop control with the oxygen sensor	In operation
Misfire detection during 200 revs.	< 5 times
Front oxygen (A/F) sensor compensation coefficient	Not in limit value
Battery voltage	> 10.9 V
Low side 1	
Secondary air injection system	Not in operation
Closed loop control with the oxygen sensor	In operation
Misfire detection during 200 revs.	< 5 times
Front oxygen (A/F) sensor compensation coefficient	Not in limit value
Battery voltage	> 10.9 V
Amount of intake air	≥ 10 g (0.35 oz)/second
Low side 2	
Secondary air injection system	Not in operation
Closed loop control with the oxygen sensor	In operation
Misfire detection during 200 revs.	< 5 times
Front oxygen (A/F) sensor compensation coefficient	Not in limit value
Battery voltage	> 10.9 V
Amount of intake air	< 10 g (0.35 oz)/second
Current continuation time of the rear oxygen sensor heater	25 seconds or more
Low side 3	
Secondary air injection system	Not in operation
Closed loop control with the oxygen sensor	In operation
Misfire detection during 200 revs.	< 5 times
Front oxygen (A/F) sensor compensation coefficient	Not in limit value
Battery voltage	> 10.9 V
Amount of intake air	< 10 g (0.35 oz)/second
Current continuation time of the rear oxygen sensor heater	25 seconds or more
Fuel cut	Experienced

#### Used only for normality judgment

Secondary Parameters	Enable Condition
Secondary air injection system	Not in operation
Closed loop control with the oxygen sensor	In operation
Misfire detection during 200 revs.	< 5 times
Front oxygen (A/F) sensor compensation coefficient	Not in limit value
Battery voltage	> 10.9 V

### 4. GENERAL DRIVING CYCLE

After starting the engine, perform the diagnosis in series while the engine is in a constant operating condition.

# Diagnostic Trouble Code (DTC) Detecting Criteria

GENERAL DESCRIPTION

## 5. DIAGNOSTIC METHOD

### Abnormality Judgment

Judge as NG if the continuous time when the following conditions are established exceeds the predetermined time, and judge as OK if it doesn't.

### Judgment Value

Malfunction Criteria	Threshold Value	DTC
High side Maximum output voltage without continuity	$\geq 1200$ mV	P0138
Low side Minimum output voltage without continuity	$< 30$ mV	P0137

### Time Needed for Diagnosis

High side: 2.5 seconds

Low side 1: 20 seconds

Low side 2: 40 seconds

Low side 3: Refer to the Map.

### Map

Fuel Cut Time (Seconds)	Time Needed for Diagnosis (Seconds)
0	40
2	40
10	60

**Malfunction Indicator Light Illumination:** Illuminates when malfunction occurs in 2 continuous driving cycles.

## 6. DTC CLEAR CONDITION

- When the OK idling cycle is completed 40 times in a row
- When "Clear Memory" is performed

## 7. MALFUNCTION INDICATOR LIGHT CLEAR CONDITION

- When the OK driving cycle is completed 3 times in a row
- When "Clear Memory" is performed

## 8. FAIL SAFE

Sub feedback control: Not allowed.

## 9. ECM OPERATION AT DTC SETTING

Memorize the freeze frame data. (For test mode \$02)

## AE:DTC P0138 O2 SENSOR CIRCUIT HIGH VOLTAGE (BANK 1 SENSOR 2)

### 1. OUTLINE OF DIAGNOSIS

NOTE:

For the detection conditions, refer to DTC P0137. <Ref. to GD(H4DOTC)-65, DTC P0137 O2 SENSOR CIRCUIT LOW VOLTAGE (BANK 1 SENSOR 2), Diagnostic Trouble Code (DTC) Detecting Criteria.>

# Diagnostic Trouble Code (DTC) Detecting Criteria

## GENERAL DESCRIPTION

### AF:DTC P0139 O2 SENSOR CIRCUIT SLOW RESPONSE (BANK 1 SENSOR 2)

#### 1. OUTLINE OF DIAGNOSIS

Detect the slow response of the oxygen sensor.

Judge as NG if either the rich to lean response diagnosis or lean to rich response diagnosis is NG, and judge as OK if both are OK.

[Rich → lean diagnosis response]

1. Measure the response time for oxygen sensor output changes when the A/F ratio changes to rich to lean. If the measured response time is larger than the threshold value, it is NG. If it is smaller, it is OK.

2. Judge as NG when the oxygen sensor voltage is large (rich) when recovering from a deceleration fuel cut.

[Lean → rich diagnosis response]

1. Measure the response time for oxygen sensor output changes when the A/F ratio changes to lean to rich. If the measured response time is larger than the threshold value, it is NG.

2. Judge as NG when the oxygen sensor voltage remains small when recovering from a deceleration fuel cut.

#### DIAGNOSTIC METHOD

Measure the response time of the output change of the oxygen sensor when the A/F ratio changes to rich to lean. And Judge as NG when the measured response time is larger than the threshold value.

#### 2. COMPONENT DESCRIPTION

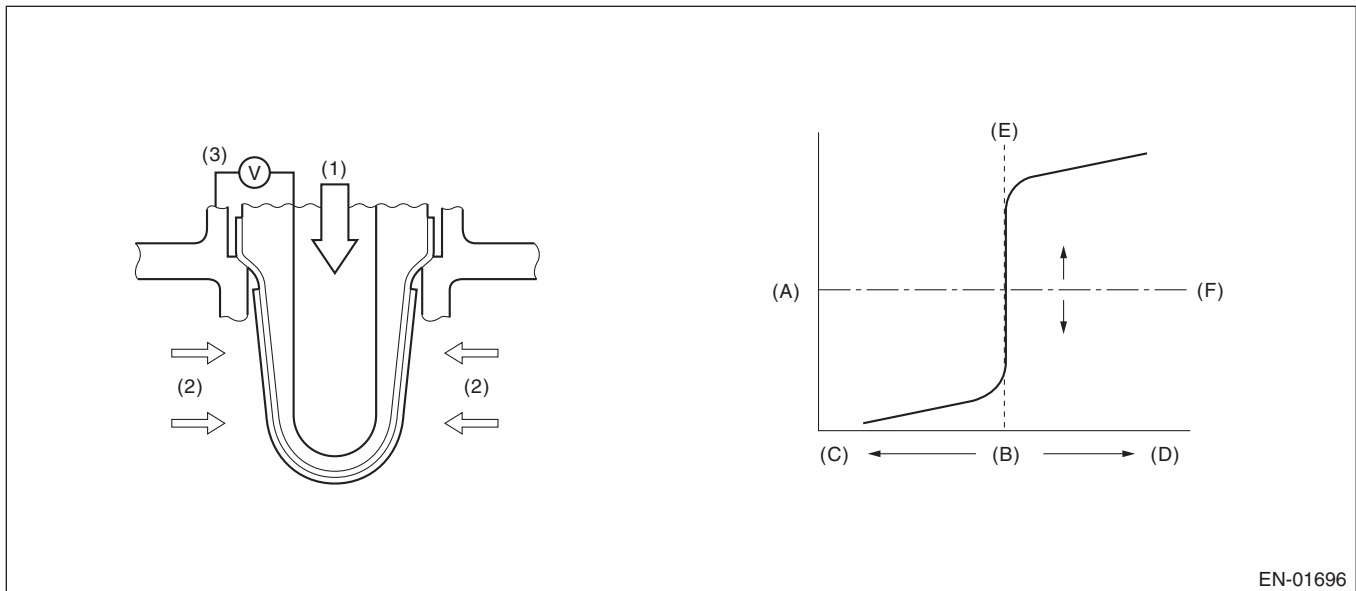

EN-01696

- (1) Atmosphere
- (2) Exhaust gas
- (3) Electromotive force

- (A) Electromotive force
- (B) Air fuel ratio
- (C) Rich

- (D) Lean
- (E) Theoretical air fuel ratio
- (F) Comparative voltage

#### 3. ENABLE CONDITION

- Rich → lean diagnosis response

Secondary Parameters	Enable Condition
Battery voltage	> 10.9 V
A/F sub feedback control condition	Complete
Deceleration fuel cut time is 5 seconds or more.	Experienced
After fuel cut	≥ 2 sec.
Rear oxygen heater current calculation time	≥ 60 sec.
Rear oxygen heater current continuous time	≥ 30 sec.
Estimated catalyst layer temperature	≥ 400 °C (752°F)

# Diagnostic Trouble Code (DTC) Detecting Criteria

GENERAL DESCRIPTION

## 4. GENERAL DRIVING CYCLE

Perform the diagnosis only once when deceleration fuel cut occurs after rapid acceleration. (Pay attention to the oxygen sensor voltage to decide on the timing of the deceleration.)

## 5. DIAGNOSTIC METHOD

When the oxygen sensor output voltage changes from 0.55 V (rich) to 0.15 V (lean), calculate the minimum response time for output change between 0.5 V and 0.2 V for the judgment criteria.

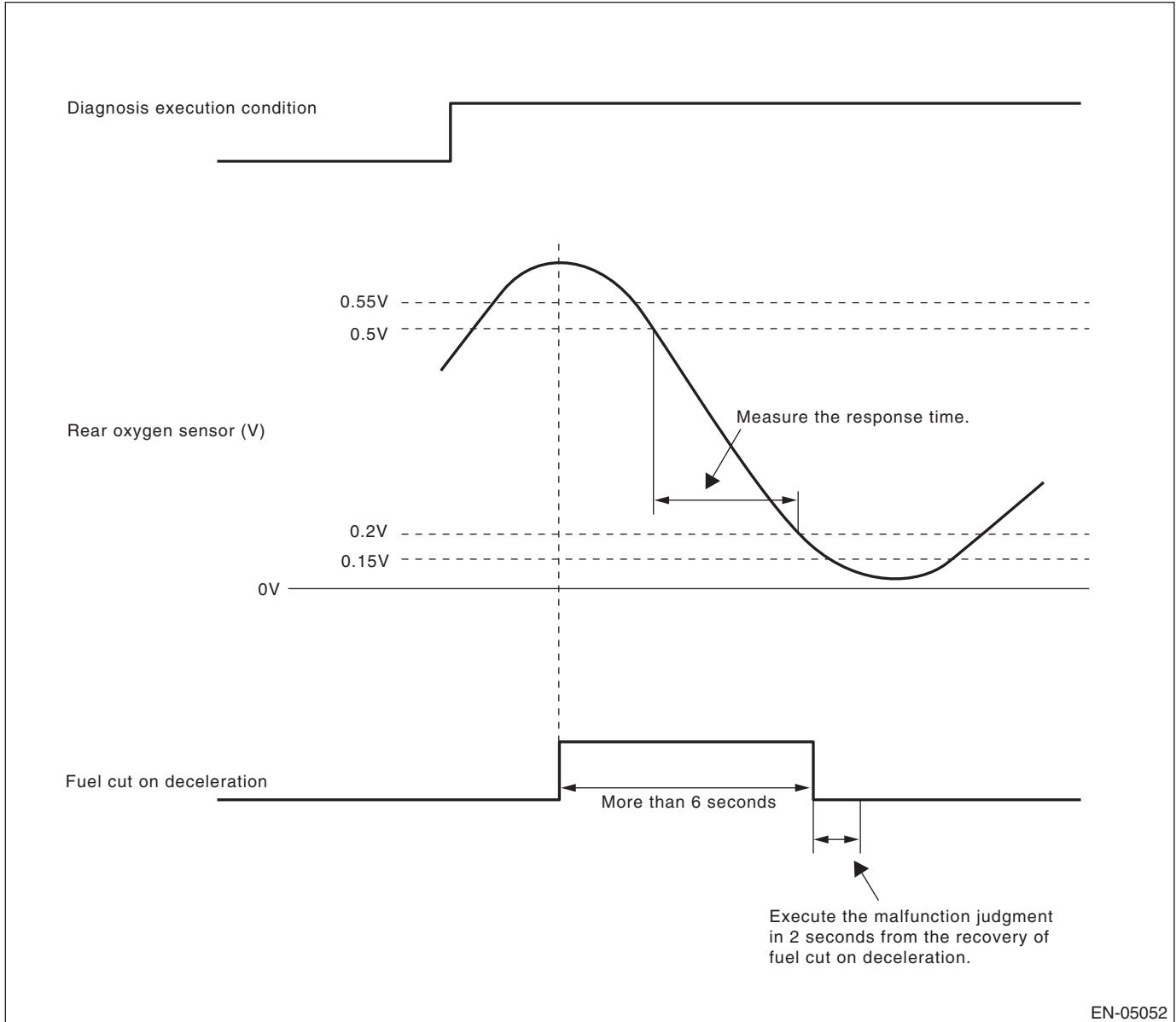

### Abnormality Judgment

1) Judge as NG when the judgment value is larger than the threshold value after deceleration fuel cut.  
Response time (diagnostic value) > threshold value → abnormal

#### NOTE:

Variation time of rear oxygen sensor output voltage is short during fuel shut-off in deceleration. Carry out the NG judgment only after the fuel shut-off in deceleration. Even without deceleration fuel cut, judge as OK if the value is below the threshold.

When the deceleration fuel cut time is more than 6 seconds, judge as NG if the following criteria are met 2 seconds after recovering from the deceleration fuel cut.

# Diagnostic Trouble Code (DTC) Detecting Criteria

## GENERAL DESCRIPTION

2) Judge as NG when the oxygen sensor voltage at recovery from a deceleration fuel cut is large. If the fuel cut time in a deceleration fuel cut is long (more than 6 s), and even after recovering from a deceleration fuel cut, the oxygen sensor voltage is high (0.55 V or more), judge as NG.

### Judgment Value

Malfunction Criteria	Threshold Value
Shortest time change from rich (0.5 V O <sub>2</sub> output) to lean (0.2 V) if voltage reduces from 0.55 V to 0.15 V.	> 0.837 seconds
Time at over 0.55 V	> 2 seconds

**Time Needed for Diagnosis:** 1 time

**Malfunction Indicator Light Illumination:** Illuminates when malfunction occurs in 2 continuous driving cycles.

### Normality Judgment

1) Regardless of a deceleration fuel cut, if the response time (diagnostic value) when the oxygen sensor voltage has changed from rich to lean is shorter than the threshold value (judgment value), judge as a normal condition.

Response time (diagnostic value)  $\leq$  threshold value  $\rightarrow$  normal

2) Normality judgement is not to be performed.

Judge as OK when the criteria below are met.

### Judgment Value

Malfunction Criteria	Threshold Value
Shortest time change from rich (0.5 V O <sub>2</sub> output) to lean (0.2 V) if voltage reduces from 0.55 V to 0.15 V.	$\leq$ 0.837 sec.

## 6. DTC CLEAR CONDITION

- When the OK idling cycle is completed 40 times in a row
- When "Clear Memory" is performed

## 7. MALFUNCTION INDICATOR LIGHT CLEAR CONDITION

- When the OK driving cycle is completed 3 times in a row
- When "Clear Memory" is performed

## 8. FAIL SAFE

Sub feedback control: Not allowed.

## 9. ECM OPERATION AT DTC SETTING

- Memorize the freeze frame data. (For test mode \$02)
- Memorize the diagnostic value and trouble standard value. (For test mode \$06)

## 10. ENABLE CONDITION

- Lean  $\rightarrow$  rich response diagnosis

Secondary Parameters	Enable Conditions
Battery voltage	> 10.9 V
A/F main feedback control condition	Completed
Deceleration fuel cut $\geq$ 5 seconds	Experienced
After fuel cut	$\geq$ 2 sec.
Current calculation time of the rear oxygen sensor heater	$\geq$ 60 sec.
Current continuation time of the rear oxygen sensor heater	$\geq$ 30 sec.

# Diagnostic Trouble Code (DTC) Detecting Criteria

GENERAL DESCRIPTION

## 11. GENERAL DRIVING CYCLE

Perform the diagnosis only once when deceleration fuel cut occurs after rapid acceleration. (Pay attention to the oxygen sensor voltage for the timing of the deceleration.)

## 12. DIAGNOSTIC METHOD

Calculate the minimum value of 0.3 V to 0.5 V output change response time as judgment value, when the oxygen sensor output voltage changes from 0.25 V (lean) to 0.55 V (rich).

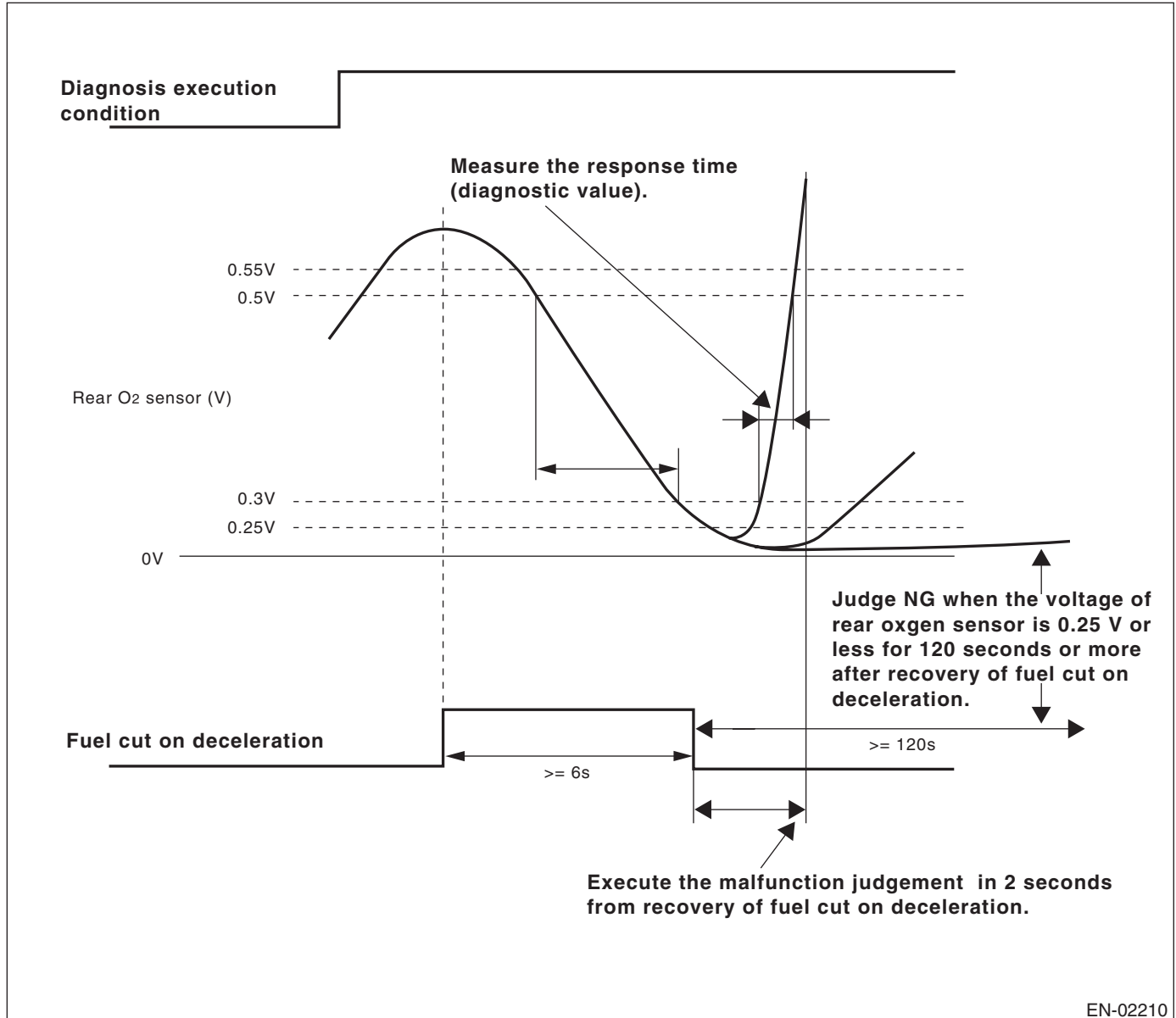

# Diagnostic Trouble Code (DTC) Detecting Criteria

## GENERAL DESCRIPTION

---

### Abnormality Judgment

1) Judge as NG when the judgment value is larger than the threshold value after deceleration fuel cut.

Response time (diagnostic value) > threshold value → abnormal

2) If the oxygen sensor voltage is small after recovering from a deceleration fuel cut, and remains small, judge as NG.

### Judgment Value

Malfunction Criteria	Threshold Value
Shortest time change from lean (0.3 V O <sub>2</sub> output) to rich (0.5 V) when voltage drops from 0.5 V to 0.25 V.	> 2 seconds
Time at less than 0.25 V	> 120 seconds

**Time Needed for Diagnosis:** 1 time

**Malfunction Indicator Light Illumination:** Illuminates when malfunction occurs in 2 continuous driving cycles.

### Normality Judgment

1) Regardless of a deceleration fuel cut, if the response time (diagnostic value) when the oxygen sensor voltage has changed from rich to lean is shorter than the threshold value (judgment value), judge as a normal condition.

Response time (diagnostic value) ≤ threshold value → normal

2) Do not judge as a normal condition.

Judge as OK when the criteria below are met.

### Judgment Value

Malfunction Criteria	Threshold Value
Shortest time change from lean (0.3 V O <sub>2</sub> output) to rich (0.5 V) when voltage drops from 0.55 V to 0.25 V.	≤ 2 sec.

## 13.DTC CLEAR CONDITION

- When the OK idling cycle is completed 40 times in a row
- When "Clear Memory" is performed

## 14.MALFUNCTION INDICATOR LIGHT CLEAR CONDITION

- When the OK driving cycle is completed 3 times in a row
- When "Clear Memory" is performed

## 15.FAIL SAFE

Sub feedback control: Not allowed.

## 16.ECM OPERATION AT DTC SETTING

- Memorize the freeze frame data. (For test mode \$02)
- Memorize the diagnostic value and trouble standard value. (For test mode \$06)



# Diagnostic Trouble Code (DTC) Detecting Criteria

GENERAL DESCRIPTION

## AG:DTC P0140 O2 SENSOR CIRCUIT NO ACTIVITY DETECTED (BANK 1 SENSOR 2)

### 1. OUTLINE OF DIAGNOSIS

Detect abnormalities in the rear oxygen sensor output property.

By referring to the intake air amount, engine coolant temperature, main feedback control, deceleration fuel cut and other operating conditions, if the rear oxygen sensor voltage should be moving under those conditions but is showing a low voltage, this is judged as a Low side NG. If the voltage is high, it is judged as a High side NG.

When either Low side or High side is NG, this is judged as an rear oxygen sensor property NG.

### 2. ENABLE CONDITION

Secondary Parameters	Enable Conditions
Engine coolant temperature	$\geq 70^{\circ}\text{C}$ (158°F)
Target output voltage of rear oxygen sensor	$\geq 0.6\text{ V}$
Air intake amount	10 g (0.35 oz)/seconds or more
Battery voltage	$> 10.9\text{ V}$
Closed loop with the oxygen sensor	In operation
Misfire detection during 200 revs.	5 times or less
Front oxygen (A/F) sensor compensation coefficient	Not in limit value
Deceleration fuel cut of 5 seconds or more	Experienced

### 3. GENERAL DRIVING CYCLE

Perform the diagnosis only once after engine warm-up.

### 4. DIAGNOSTIC METHOD

#### Abnormality Judgment

When the following conditions are established, it is NG.

#### Judgment Value

Malfunction Criteria	Threshold Value
Maximum output voltage, low side	$< 550\text{ mV}$
Minimum output voltage, high side	$> 250\text{ mV}$

**Time Needed for Diagnosis:** 200 seconds

**Malfunction Indicator Light Illumination:** Illuminates when malfunction occurs in 2 continuous driving cycles.

#### Normality Judgment

When the following conditions are established, it is OK.

#### Judgment Value

Malfunction Criteria	Threshold Value
Maximum output voltage, low side	$\geq 550\text{ mV}$
Minimum output voltage, high side	$\leq 250\text{ mV}$

### 5. DTC CLEAR CONDITION

- When the OK idling cycle is completed 40 times in a row
- When "Clear Memory" is performed

# Diagnostic Trouble Code (DTC) Detecting Criteria

## GENERAL DESCRIPTION

---

### 6. MALFUNCTION INDICATOR LIGHT CLEAR CONDITION

- When the OK driving cycle is completed 3 times in a row
- When “Clear Memory” is performed

### 7. FAIL SAFE

None

### 8. ECM OPERATION AT DTC SETTING

- Memorize the freeze frame data. (For test mode \$02)
- Memorize the diagnostic value and trouble standard value. (For test mode \$06)

## AH:DTC P0171 SYSTEM TOO LEAN (BANK 1)

### 1. OUTLINE OF DIAGNOSIS

Detect fuel system malfunction by the amount of main feedback control.

### FUEL SYSTEM DIAGNOSIS

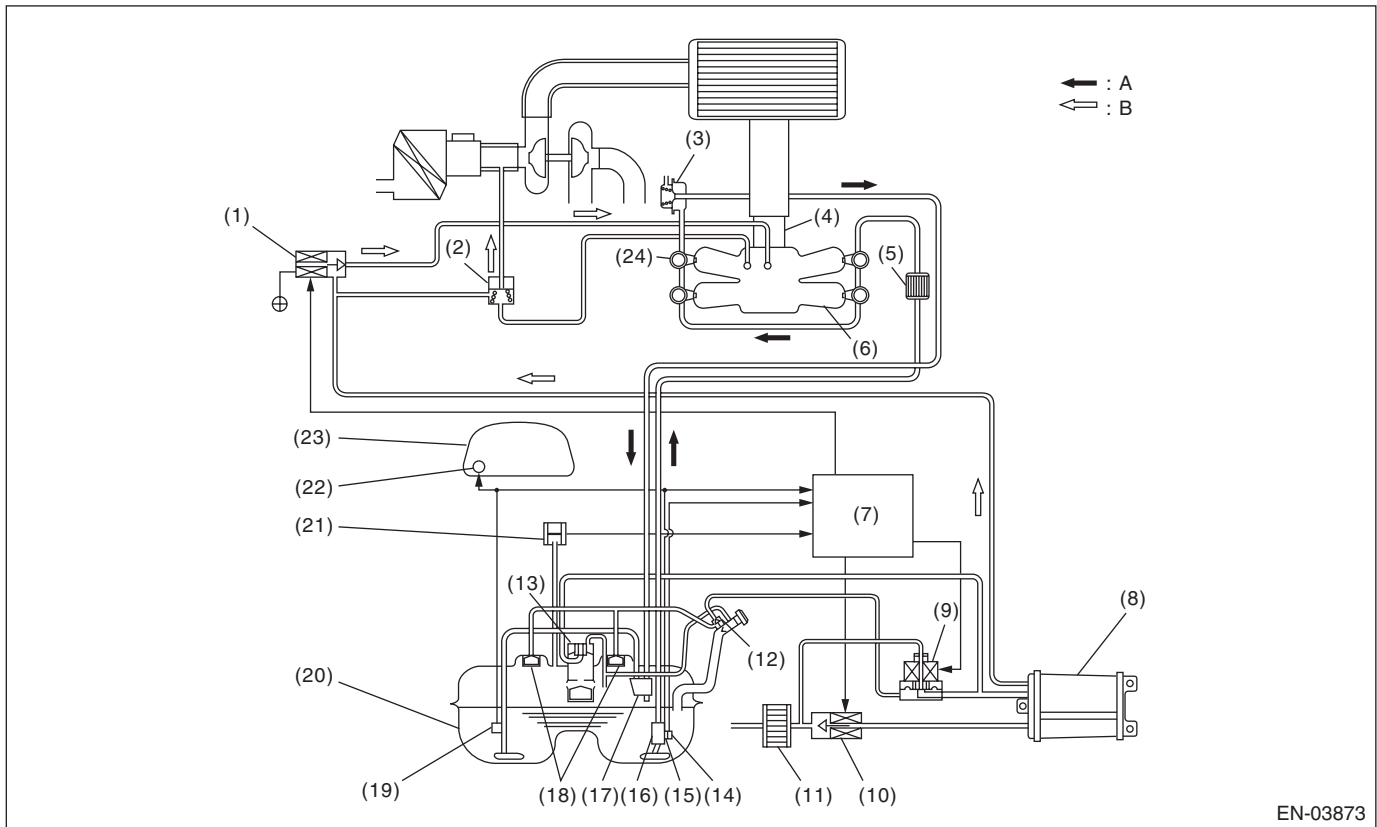

- |                                     |                                |
|-------------------------------------|--------------------------------|
| (1) Purge control solenoid valve    | (14) Fuel temperature sensor   |
| (2) Purge valve                     | (15) Fuel level sensor         |
| (3) Pressure regulator              | (16) Fuel pump                 |
| (4) Throttle body                   | (17) Jet pump                  |
| (5) Fuel filter                     | (18) Fuel cut valve            |
| (6) Intake manifold                 | (19) Fuel sub level sensor     |
| (7) Engine control module (ECM)     | (20) Fuel tank                 |
| (8) Canister                        | (21) Fuel tank pressure sensor |
| (9) Pressure control solenoid valve | (22) Fuel gauge                |
| (10) Drain valve                    | (23) Combination meter         |
| (11) Drain filter                   | (24) Fuel injector             |
| (12) Shut-off valve                 | (A) Fuel line                  |
| (13) Vent valve                     | (B) Vaporized fuel line        |

### Diagnostic Method

Fuel system is diagnosed by comparing the target air fuel ratio calculated by ECM with the actual air fuel ratio measured by sensor.

# Diagnostic Trouble Code (DTC) Detecting Criteria

## GENERAL DESCRIPTION

### 2. ENABLE CONDITION

Secondary Parameters	Enable Conditions
A/F main learning system	In operation
Engine coolant temperature	$\geq 70^{\circ}\text{C}$ (158°F)
Engine load	$\geq$ Value from Map 5
Intake air change during 0.5 engine revs.	$\leq 0.02$ g/rev

#### Map 5

engine speed (rpm)	idling	800	1200	1600	2000	2400	2800	3200	3600	4000	4400
Measured value (g(oz)/rev)	Non-turbo	0.228 (0.008)	0.22 (0.0078)	0.22 (0.0078)	0.22 (0.0078)	0.228 (0.008)	0.23 0.0081	0.234 (0.0083)	0.242 (0.0085)	0.250 (0.0088)	0.250 (0.0088)

### 3. GENERAL DRIVING CYCLE

Perform the diagnosis continuously at idling or at a constant speed after warming up the engine.

### 4. DIAGNOSTIC METHOD

#### Abnormality Judgment

Compare the diagnosed value (fsobd) with the threshold value, and if a condition where the malfunction criteria below are met continues for more than 50 seconds, judge that there is a fault in the fuel system.

#### Judgment Value

Malfunction Criteria	Threshold Value
$\text{fsobd} = (\text{sglmd} - \text{tglm da}) + \text{faf} + \text{flaf}$ where, sglmd = measured lambda tglm da = target lambda faf = main feedback compensation coefficient every 64 milliseconds flaf = main feedback learning compensation coefficient	$\geq \text{fsobdL1}$ See Map 4 fsobdL1 = lean side threshold value of fsobd

#### Map 4 Threshold value for fuel system malfunction criteria

Amount of air (g(oz)/s)	0	2.4 (0.085)	4.7 (0.166)	7 (0.247)	9.4 (0.332)	11.7 (0.413)	14.1 (0.497)
fsobdL1 (%)	40	40	36.9	32.0	27.0	26.5	26.5

**Time Needed for Diagnosis:** 10 seconds  $\times$  5 time

**Malfunction Indicator Light Illumination:** Illuminates when malfunction occurs in 2 continuous driving cycles.

#### Normality Judgment

Judge as OK when the malfunction criteria below are completed for 10 seconds or more.

#### Judgment Value

Malfunction Criteria	Threshold Value
$\text{fsobd} = (\text{sglmd} - \text{tglm da}) + \text{faf} + \text{flaf}$	$< 19\%$

### 5. DTC CLEAR CONDITION

- When the OK idling cycle is completed 40 times in a row
- When "Clear Memory" is performed

### 6. MALFUNCTION INDICATOR LIGHT CLEAR CONDITION

- When similar driving conditions are repeated 3 times and the result is OK.
- When "Clear Memory" is performed

# Diagnostic Trouble Code (DTC) Detecting Criteria

GENERAL DESCRIPTION

---

## 7. FAIL SAFE

Rich side malfunction

- Purge control solenoid valve control: Not allowed to purge.
- Heavy fuel judgment control: Not allowed to carry out the heavy judgment.

## 8. ECM OPERATION AT DTC SETTING

Memorize the freeze frame data. (For test mode \$02)

# Diagnostic Trouble Code (DTC) Detecting Criteria

## GENERAL DESCRIPTION

### AI: DTC P0172 SYSTEM TOO RICH (BANK 1)

#### 1. OUTLINE OF DIAGNOSIS

Detect fuel system malfunction by the amount of main feedback control.

#### FUEL SYSTEM DIAGNOSIS

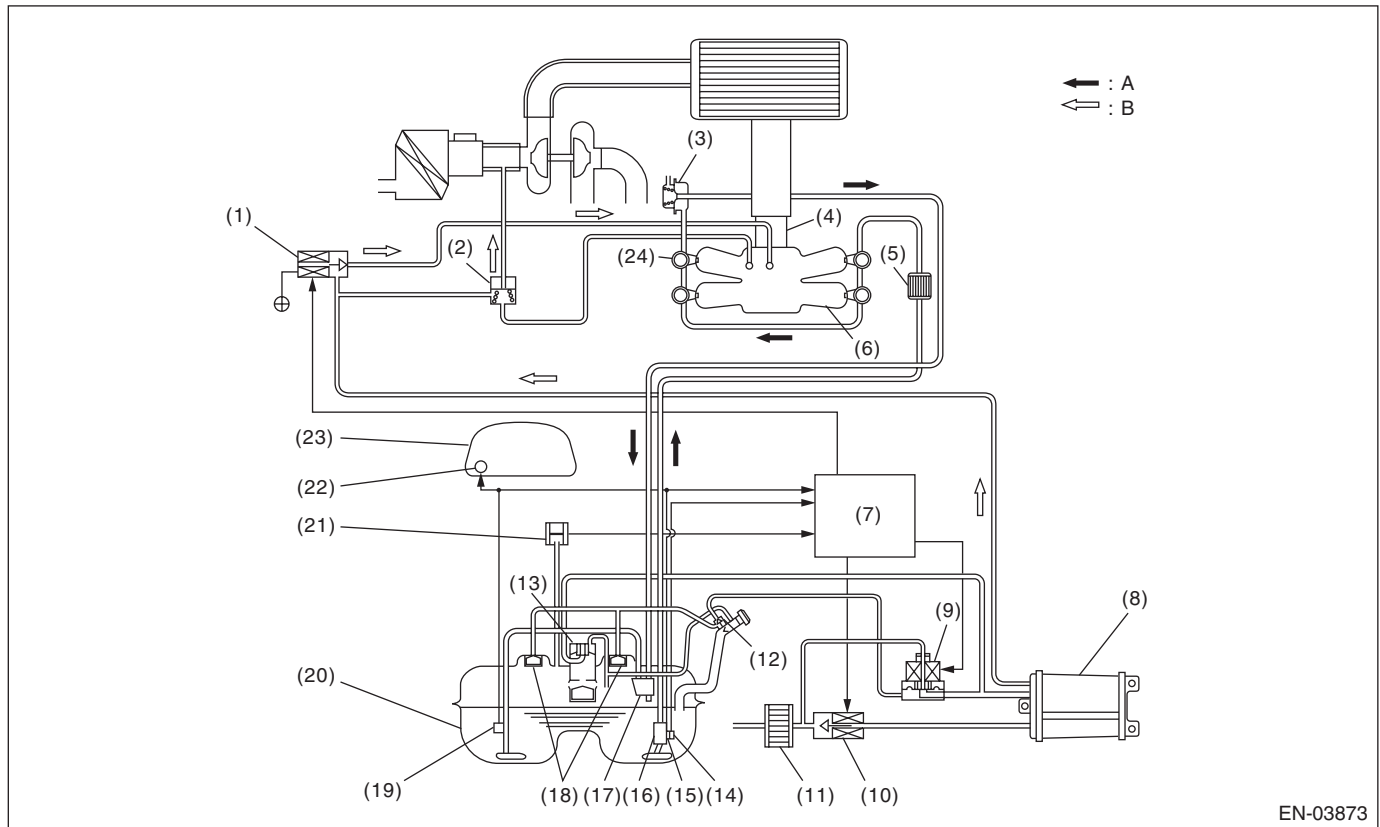

EN-03873

- |                                     |                                |
|-------------------------------------|--------------------------------|
| (1) Purge control solenoid valve    | (14) Fuel temperature sensor   |
| (2) Purge valve                     | (15) Fuel level sensor         |
| (3) Pressure regulator              | (16) Fuel pump                 |
| (4) Throttle body                   | (17) Jet pump                  |
| (5) Fuel filter                     | (18) Fuel cut valve            |
| (6) Intake manifold                 | (19) Fuel sub level sensor     |
| (7) Engine control module (ECM)     | (20) Fuel tank                 |
| (8) Canister                        | (21) Fuel tank pressure sensor |
| (9) Pressure control solenoid valve | (22) Fuel gauge                |
| (10) Drain valve                    | (23) Combination meter         |
| (11) Drain filter                   | (24) Fuel injector             |
| (12) Shut-off valve                 | (A) Fuel line                  |
| (13) Vent valve                     | (B) Vaporized fuel line        |

#### Diagnostic Method

Fuel system is diagnosed by comparing the target air fuel ratio calculated by ECM with the actual air fuel ratio measured by sensor.

# Diagnostic Trouble Code (DTC) Detecting Criteria

GENERAL DESCRIPTION

## 2. ENABLE CONDITION

Secondary Parameters	Enable Conditions
A/F main learning system	In operation
Engine coolant temperature	$\geq 70^{\circ}\text{C}$ (158°F)
Engine load	$\geq$ Value from Map 5
Intake air change during 0.5 engine revs.	$\leq 0.02$ g/rev
Learning value of EVAP conc. during purge	$\leq 0.1$
Cumulative time of canister purge after engine start	20 seconds or more
Continuous period after canister purge starting	30 seconds or more

### Map 5

Engine speed (rpm)	idling	800	1200	1600	2000	2400	2800	3200	3600	4000	4400
Measured value (g(oz)/rev)	Non-turbo	0.228 (0.008)	0.22 (0.0078)	0.22 (0.0078)	0.22 (0.0078)	0.228 (0.008)	0.23 0.0081	0.234 (0.0083)	0.242 (0.0085)	0.250 (0.0088)	0.250 (0.0088)

## 3. GENERAL DRIVING CYCLE

Perform the diagnosis continuously at idling or at a constant speed after warming up the engine.

## 4. DIAGNOSTIC METHOD

### Abnormality Judgment

Compare the diagnosed value (fsobd) with the threshold value, and if a condition where the malfunction criteria below are met continues for more than 50 seconds, judge that there is a fault in the fuel system.

### Judgment Value

Malfunction Criteria	Threshold Value
$\text{fsobd} = (\text{sglmd} - \text{tglm da}) + \text{faf} + \text{flaf}$ where, sglmd = measured lambda tglm da = target lambda faf = Main feedback compensation coefficient (Per 64 milliseconds) flaf = main feedback learning compensation coefficient	$\leq \text{fsobdR1}$ See Map 4 fsobdR1 = rich side threshold value of fsobd

### Map 4 Threshold value for fuel system malfunction criteria

Amount of air (g(oz)/s)	0	2.4(0.085)	4.7(0.166)	7(0.247)	9.4(0.332)	11.7(0.413)	14.1(0.497)
fsobdR1 (%)	-40	-40	-36.9	-32.0	-27.0	-27.0	-27.0

**Time Needed for Diagnosis:** 10 seconds  $\times$  5 time

**Malfunction Indicator Light Illumination:** Illuminates when malfunction occurs in 2 continuous driving cycles.

### Normality Judgment

Judge as OK when the malfunction criteria below continues for 10 seconds.

### Judgment Value

Malfunction Criteria	Threshold Value
$\text{fsobd} = (\text{sglmd} - \text{tglm da}) + \text{faf} + \text{flaf}$	$\geq -20\%$

## 5. DTC CLEAR CONDITION

- When the OK idling cycle is completed 40 times in a row
- When "Clear Memory" is performed

# Diagnostic Trouble Code (DTC) Detecting Criteria

## GENERAL DESCRIPTION

---

### 6. MALFUNCTION INDICATOR LIGHT CLEAR CONDITION

- When similar driving conditions are repeated 3 times and the result is OK.
- When “Clear Memory” is performed

### 7. FAIL SAFE

Rich side malfunction

- Purge control solenoid valve control: Not allowed to purge.
- Heavy fuel judgment control: Not allowed to carry out the heavy judgment.

### 8. ECM OPERATION AT DTC SETTING

Memorize the freeze frame data. (For test mode \$02)



# Diagnostic Trouble Code (DTC) Detecting Criteria

GENERAL DESCRIPTION

## AJ:DTC P0181 FUEL TEMPERATURE SENSOR "A" CIRCUIT RANGE/ PERFORMANCE

### 1. OUTLINE OF DIAGNOSIS

Detect faults in the fuel temperature sensor output properties.

Diagnosis is performed in two methods; drift diagnosis and stuck diagnosis. If either is NG, judge as NG. If both are OK, Judge as OK and clear the NG.

#### DRIFT DIAGNOSIS

Normally fuel temperature is lower than engine coolant temperature. When the fuel temperature becomes higher than the engine coolant temperature, the range is considered to be shifted, and judged as NG.

### 2. COMPONENT DESCRIPTION

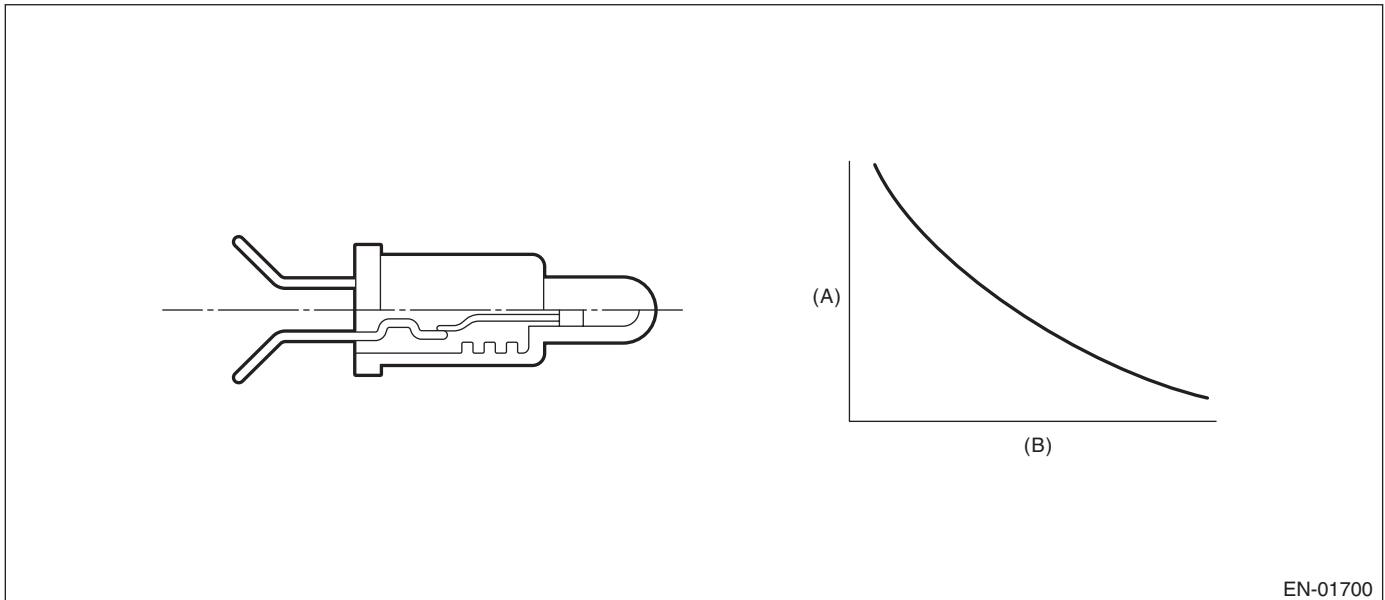

(A) Resistance value ( $\Omega$ )

(B) Temperature  $^{\circ}\text{C}$  ( $^{\circ}\text{F}$ )

### 3. ENABLE CONDITION

Secondary Parameters	Enable Conditions
None	

### 4. GENERAL DRIVING CYCLE

Always perform the diagnosis continuously.

# Diagnostic Trouble Code (DTC) Detecting Criteria

## GENERAL DESCRIPTION

---

### 5. DIAGNOSTIC METHOD

#### Abnormality Judgment

Judge as NG when the continuous time of meeting the malfunction criteria below becomes 120 seconds or more.

#### Judgment Value

Malfunction Criteria	Threshold Value
Fuel level	$\geq 9 \text{ l}$ (2.38 US gal, 1.98 Imp gal)
After engine starting	20 seconds or more
Engine coolant temperature — engine coolant temperature at engine starting	$> 10^{\circ}\text{C}$ (18°F)
Fuel temperature – Engine coolant temperature	$\geq 10^{\circ}\text{C}$ (18°F)
Battery voltage	$> 10.9 \text{ V}$

**Time Needed for Diagnosis:** 120 seconds

**Malfunction Indicator Light Illumination:** Illuminates when malfunction occurs in 2 continuous driving cycles.

#### Normality Judgment

Judge as OK when the criteria below are met.

#### Judgment Value

Malfunction Criteria	Threshold Value
Fuel level	$\geq 9 \text{ l}$ (2.38 US gal, 1.98 Imp gal)
After engine starting	20 seconds or more
Engine coolant temperature — engine coolant temperature at engine starting	$> 10^{\circ}\text{C}$ (18°F)
Fuel temperature – Engine coolant temperature	$< 10^{\circ}\text{C}$ (18°F)
Battery voltage	$> 10.9 \text{ V}$
Engine coolant temperature	$< 70^{\circ}\text{C}$ (158°F)

#### Stuck Diagnosis

As the engine warms up (cumulative amount of intake air after starting is large), if the fuel temperature which should rise does not, determine as being stuck and NG.

### 6. ENABLE CONDITION

Secondary Parameters	Enable Conditions
After engine starting	20 seconds or more
Battery voltage	$> 10.9 \text{ V}$

### 7. GENERAL DRIVING CYCLE

Always perform diagnosis continuously after 20 seconds or more have passed since the engine started.

# Diagnostic Trouble Code (DTC) Detecting Criteria

GENERAL DESCRIPTION

## 8. DIAGNOSTIC METHOD

### Abnormality Judgment

Judge as NG when the malfunction criteria below are met.

### Judgment Value

Malfunction Criteria	Threshold Value
Accumulated amount of intake air	≥ 550 kg (1212.8 lb)
Fuel temperature difference between Max. and Min.	< 3°C (5.4°F)

**Time Needed for Diagnosis:** Undetermined

**Malfunction Indicator Light Illumination:** Illuminates when malfunction occurs in 2 continuous driving cycles.

### Normality Judgment

Judge as OK when the criteria below are met.

### Judgment Value

Malfunction Criteria	Threshold Value
Accumulated amount of intake air	≥ 550 kg (1212.8 lb)
Fuel temperature difference between Max. and Min.	≥ 3°C (5.4°F)

## 9. DTC CLEAR CONDITION

- When the OK idling cycle is completed 40 times in a row
- When "Clear Memory" is performed

## 10.MALFUNCTION INDICATOR LIGHT CLEAR CONDITION

- When the OK driving cycle is completed 3 times in a row
- When "Clear Memory" is performed

## 11.FAIL SAFE

None

## 12.ECM OPERATION AT DTC SETTING

Memorize the freeze frame data. (For test mode \$02)

# Diagnostic Trouble Code (DTC) Detecting Criteria

## GENERAL DESCRIPTION

### AK:DTC P0182 FUEL TEMPERATURE SENSOR "A" CIRCUIT LOW INPUT

#### 1. OUTLINE OF DIAGNOSIS

Detect the open or short circuit of fuel temperature sensor.

Judge as NG if it is out of specification.

#### 2. COMPONENT DESCRIPTION

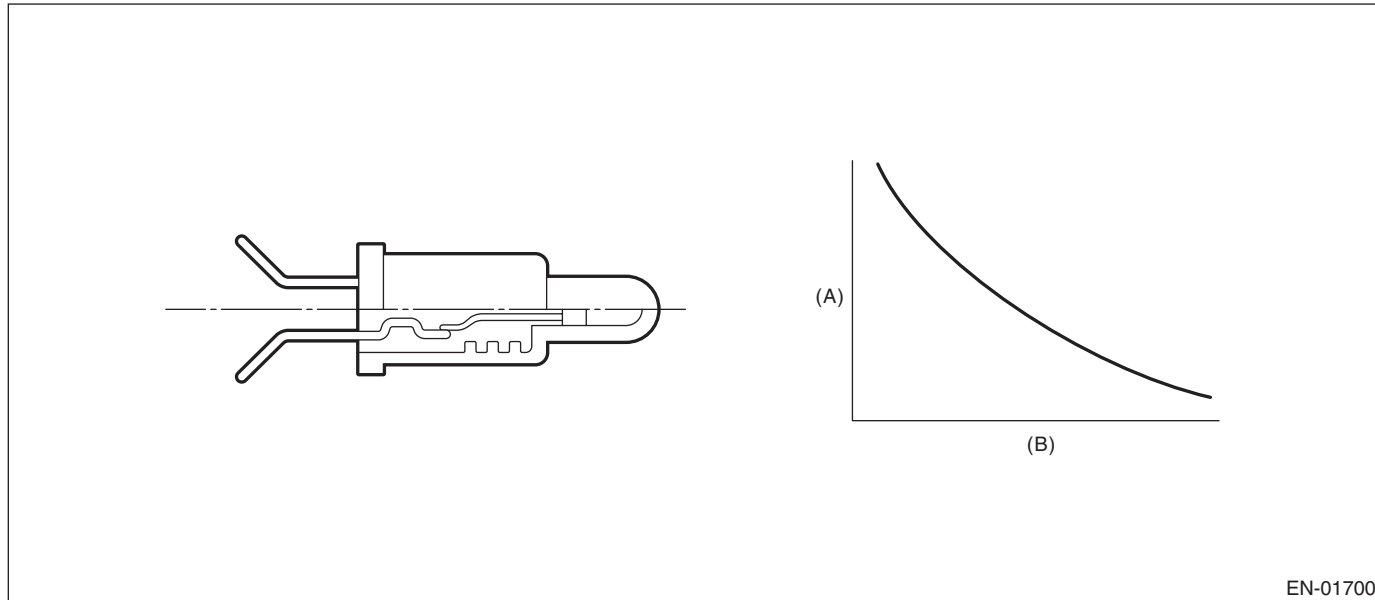

(A) Resistance value ( $\Omega$ )

(B) Temperature  $^{\circ}\text{C}$  ( $^{\circ}\text{F}$ )

#### 3. ENABLE CONDITION

Secondary Parameters	Enable Conditions
None	

#### 4. GENERAL DRIVING CYCLE

Always perform the diagnosis continuously.

#### 5. DIAGNOSTIC METHOD

##### Abnormality Judgment

Judge as NG when the continuous time of meeting the malfunction criteria below becomes 2.5 seconds or more.

##### Judgment Value

Malfunction Criteria	Threshold Value
Output voltage	$< 0.1646 \text{ V}$
Battery voltage	$\geq 10.9 \text{ V}$

**Time Needed for Diagnosis:** 2.5 seconds

**Malfunction Indicator Light Illumination:** Illuminates as soon as a malfunction occurs.

##### Normality Judgment

Judge as OK and clear the NG when the malfunction criteria below are met.

##### Judgment Value

Malfunction Criteria	Threshold Value
Output voltage	$\geq 0.1646 \text{ V}$
Battery voltage	$\geq 10.9 \text{ V}$

# Diagnostic Trouble Code (DTC) Detecting Criteria

GENERAL DESCRIPTION

---

## 6. DTC CLEAR CONDITION

- When the OK idling cycle is completed 40 times in a row
- When "Clear Memory" is performed

## 7. MALFUNCTION INDICATOR LIGHT CLEAR CONDITION

- When the OK driving cycle is completed 3 times in a row
- When "Clear Memory" is performed

## 8. FAIL SAFE

None

## 9. ECM OPERATION AT DTC SETTING

Memorize the freeze frame data. (For test mode \$02)

# Diagnostic Trouble Code (DTC) Detecting Criteria

## GENERAL DESCRIPTION

### AL:DTC P0183 FUEL TEMPERATURE SENSOR "A" CIRCUIT HIGH INPUT

#### 1. OUTLINE OF DIAGNOSIS

Detect the open or short circuit of fuel temperature sensor.  
Judge as NG if it is out of specification.

#### 2. COMPONENT DESCRIPTION

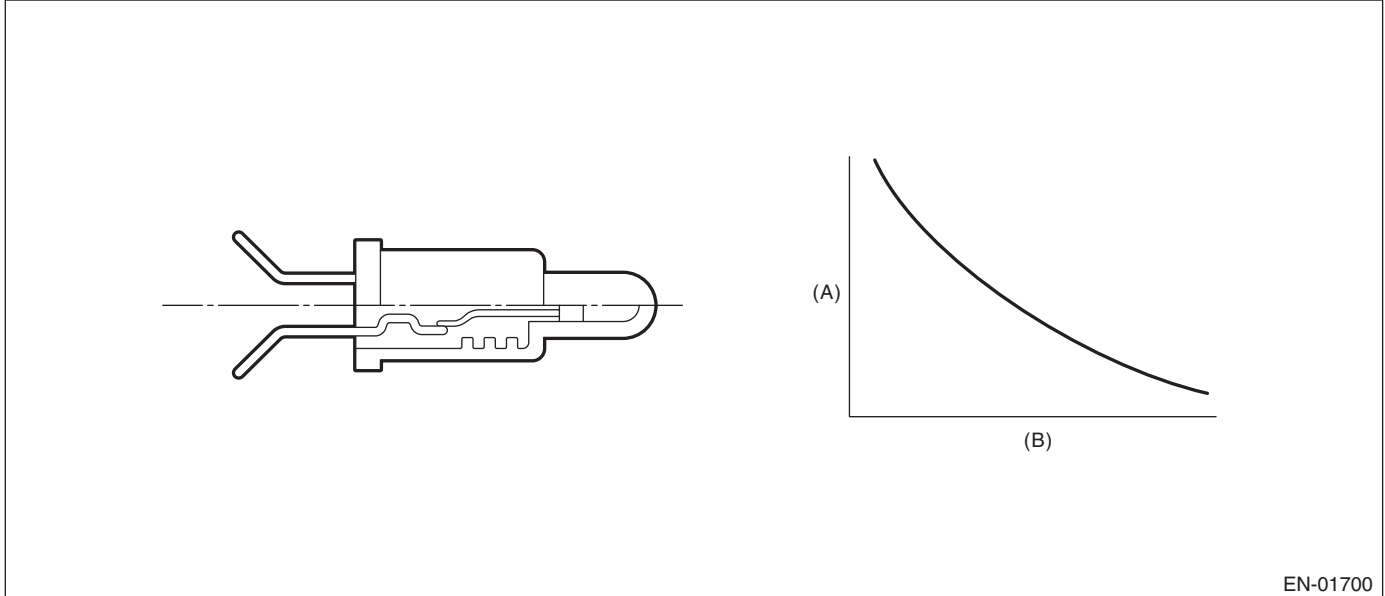

EN-01700

(A) Resistance value ( $\Omega$ )

(B) Temperature  $^{\circ}\text{C}$  ( $^{\circ}\text{F}$ )

#### 3. ENABLE CONDITION

Secondary Parameters	Enable Conditions
None	

#### 4. GENERAL DRIVING CYCLE

Always perform the diagnosis continuously.

#### 5. DIAGNOSTIC METHOD

##### Abnormality Judgment

Judge as NG when the continuous time of meeting the malfunction criteria below becomes 2.5 seconds or more.

##### Judgment Value

Malfunction Criteria	Threshold Value
Output voltage	$\geq 4.72 \text{ V}$
Battery voltage	$\geq 10.9 \text{ V}$

**Time Needed for Diagnosis:** 2.5 seconds

**Malfunction Indicator Light Illumination:** Illuminates as soon as a malfunction occurs.

##### Normality Judgment

Judge as OK and clear the NG when the malfunction criteria below are met.

##### Judgment Value

Malfunction Criteria	Threshold Value
Output voltage	$< 4.72 \text{ V}$
Battery voltage	$\geq 10.9 \text{ V}$

# Diagnostic Trouble Code (DTC) Detecting Criteria

GENERAL DESCRIPTION

---

## 6. DTC CLEAR CONDITION

- When the OK idling cycle is completed 40 times in a row
- When "Clear Memory" is performed

## 7. MALFUNCTION INDICATOR LIGHT CLEAR CONDITION

- When the OK driving cycle is completed 3 times in a row
- When "Clear Memory" is performed

## 8. FAIL SAFE

None

## 9. ECM OPERATION AT DTC SETTING

Memorize the freeze frame data. (For test mode \$02)

# Diagnostic Trouble Code (DTC) Detecting Criteria

## GENERAL DESCRIPTION

### AM:DTC P0222 THROTTLE/PEDAL POSITION SENSOR/SWITCH “B” CIRCUIT LOW

#### 1. OUTLINE OF DIAGNOSIS

Detect the open or short circuit of throttle position sensor 2.  
Judge as NG if it is out of specification.

#### 2. COMPONENT DESCRIPTION

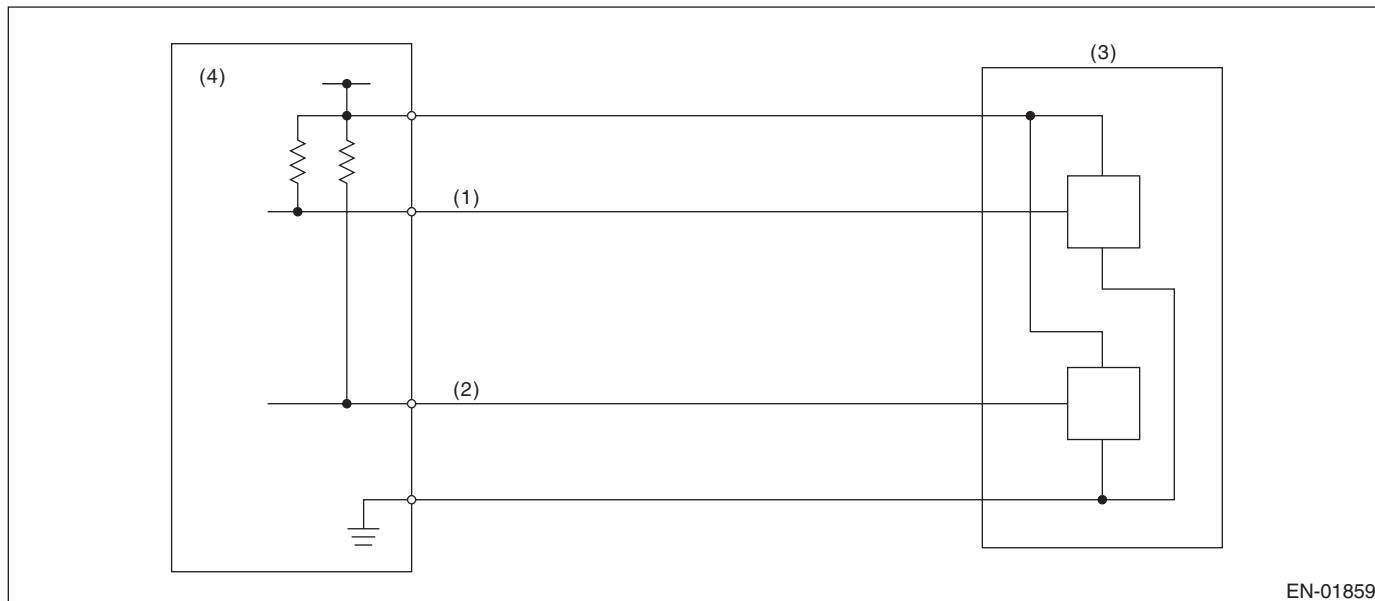

- (1) Throttle position sensor 1 signal
- (2) Throttle position sensor 2 signal
- (3) Throttle position sensor
- (4) Engine control module (ECM)

#### 3. ENABLE CONDITION

Secondary Parameters	Enable Conditions
Ignition switch	ON

#### 4. GENERAL DRIVING CYCLE

Always perform the diagnosis continuously.

#### 5. DIAGNOSTIC METHOD

Judge as OK and clear the NG when the malfunction criteria below are met.

##### Judgment Value

Malfunction Criteria	Threshold Value
Sensor 1 input voltage	> 0.224 V

**Time Needed for Diagnosis:** 24 milliseconds

**Malfunction Indicator Light Illumination:** Illuminates as soon as a malfunction occurs.

#### 6. DTC CLEAR CONDITION

- When the OK idling cycle is completed 40 times in a row
- When “Clear Memory” is performed (Only with engine stopped)

#### 7. MALFUNCTION INDICATOR LIGHT CLEAR CONDITION

- When the OK driving cycle is completed 3 times in a row
- When “Clear Memory” is performed (Only with engine stopped)



## Diagnostic Trouble Code (DTC) Detecting Criteria

GENERAL DESCRIPTION

---

### 8. FAIL SAFE

Stop the continuity to the electronic throttle control motor. (Throttle opening is fixed to 6°.)

### 9. ECM OPERATION AT DTC SETTING

Memorize the freeze frame data. (For test mode \$02)

# Diagnostic Trouble Code (DTC) Detecting Criteria

## GENERAL DESCRIPTION

### AN:DTC P0223 THROTTLE/PEDAL POSITION SENSOR/SWITCH “B” CIRCUIT HIGH

#### 1. OUTLINE OF DIAGNOSIS

Detect the open or short circuit of throttle position sensor 2.

Judge as NG if it is out of specification.

#### 2. COMPONENT DESCRIPTION

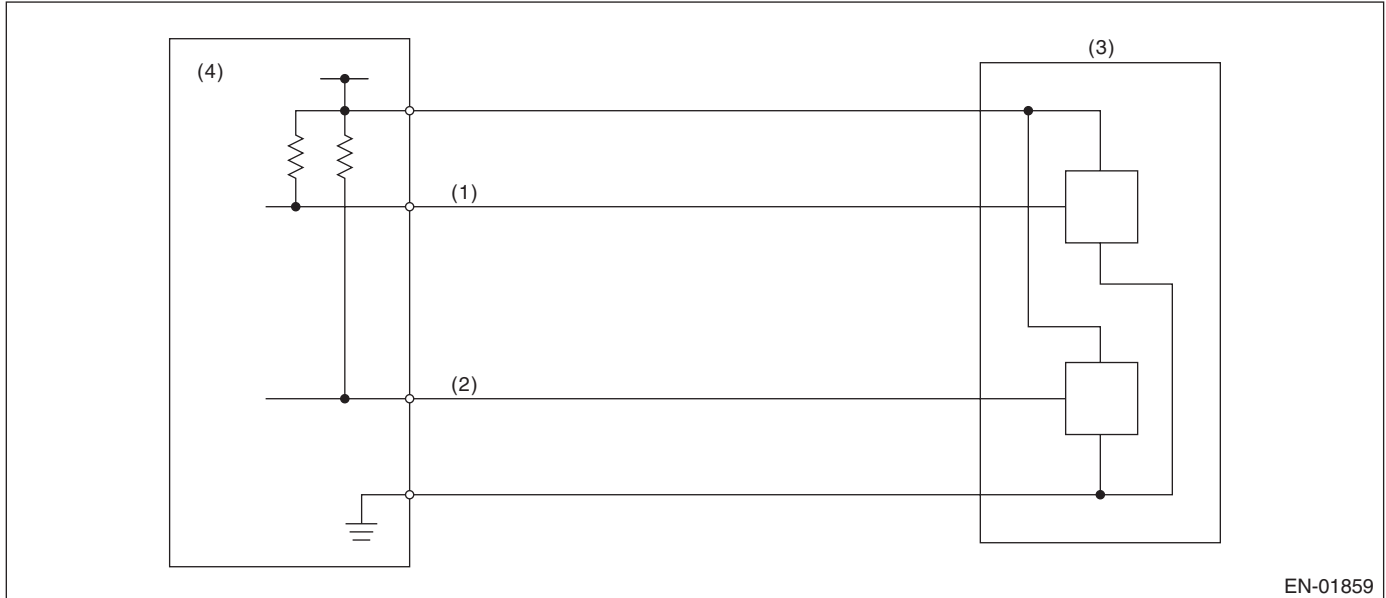

- (1) Throttle position sensor 1 signal
- (2) Throttle position sensor 2 signal
- (3) Throttle position sensor
- (4) Engine control module (ECM)

#### 3. ENABLE CONDITION

Secondary Parameters	Enable Conditions
Ignition switch	ON

#### 4. GENERAL DRIVING CYCLE

Always perform the diagnosis continuously.

#### 5. DIAGNOSTIC METHOD

Judge as OK and clear the NG when the malfunction criteria below are met.

##### Judgment Value

Malfunction Criteria	Threshold Value
Sensor 1 input voltage	< 4.851 V

**Time Needed for Diagnosis:** 24 milliseconds

**Malfunction Indicator Light Illumination:** Illuminates as soon as a malfunction occurs.

#### 6. DTC CLEAR CONDITION

- When the OK idling cycle is completed 40 times in a row
- When “Clear Memory” is performed (Only with engine stopped)

#### 7. MALFUNCTION INDICATOR LIGHT CLEAR CONDITION

- When the OK driving cycle is completed 3 times in a row
- When “Clear Memory” is performed (Only with engine stopped)

## Diagnostic Trouble Code (DTC) Detecting Criteria

GENERAL DESCRIPTION

---

### **8. FAIL SAFE**

Stop the continuity to the electronic throttle control motor. (Throttle opening is fixed to 6°.)

### **9. ECM OPERATION AT DTC SETTING**

Memorize the freeze frame data. (For test mode \$02)

# Diagnostic Trouble Code (DTC) Detecting Criteria

## GENERAL DESCRIPTION

### AO:DTC P0230 FUEL PUMP PRIMARY CIRCUIT

#### 1. OUTLINE OF DIAGNOSIS

Detect the malfunction of fuel pump control unit.

Judge as NG when the NG signal is sent through a diagnostic line coming from the fuel pump control unit.

Fuel pump control unit detects the open or short circuit malfunction for each line, and then sends NG signals if one of them is found NG.

#### 2. COMPONENT DESCRIPTION

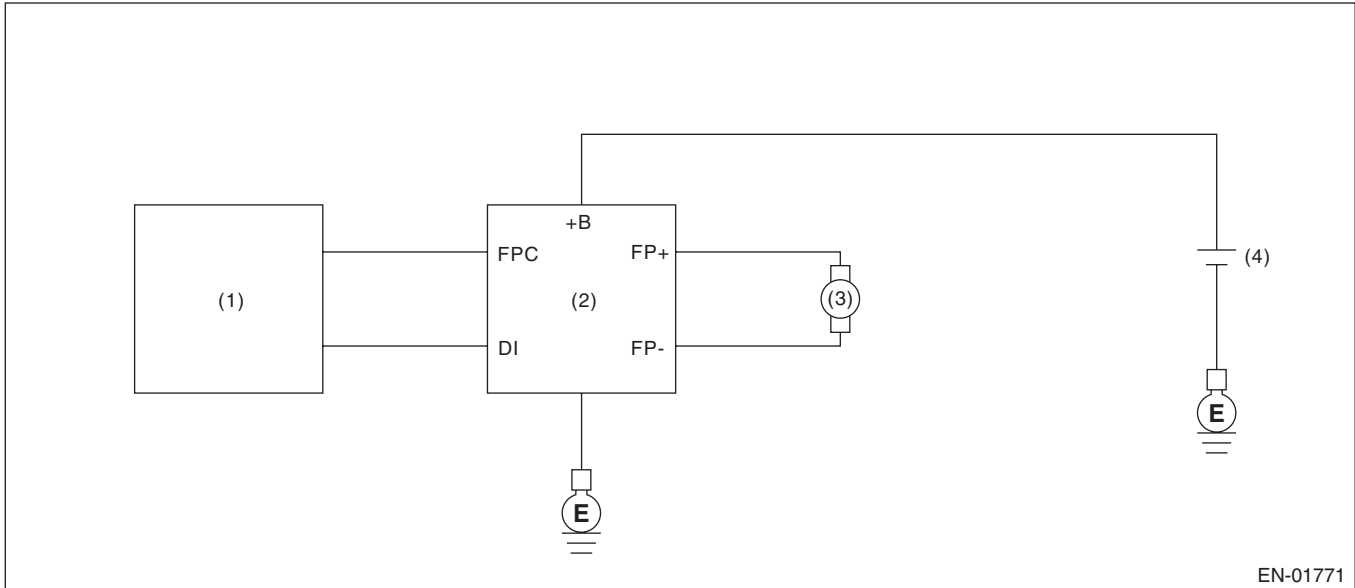

- (1) Engine control module (ECM)
- (2) Fuel pump control unit
- (3) Fuel pump
- (4) Battery

#### 3. ENABLE CONDITION

Secondary Parameters	Enable Conditions
None	

#### 4. GENERAL DRIVING CYCLE

Always perform the diagnosis continuously.

# Diagnostic Trouble Code (DTC) Detecting Criteria

GENERAL DESCRIPTION

## 5. DIAGNOSTIC METHOD

### Abnormality Judgment

Judge as NG when the continuous time of meeting the malfunction criteria below becomes 2.5 seconds or more.

### Judgment Value

Malfunction Criteria	Threshold Value
Battery voltage	$\geq 8$ V
After engine starting	30 seconds or more
Fuel pump control	ON
Fuel pump control unit output diagnosis signal	Low
Fuel level	$\geq 10$ ℓ (2.64 US gal, 2.2 Imp gal)

**Time Needed for Diagnosis:** 2.5 seconds

**Malfunction Indicator Light Illumination:** Illuminates when malfunction occurs in 2 continuous driving cycles.

### Normality Judgment

Judge as OK and clear the NG when the malfunction criteria below are met.

### Judgment Value

Malfunction Criteria	Threshold Value
Battery voltage	$\geq 8$ V
After engine starting	30 seconds or more
Fuel pump control	ON
Fuel pump control unit output diagnosis signal	High

## 6. DTC CLEAR CONDITION

- When the OK idling cycle is completed 40 times in a row
- When "Clear Memory" is performed

## 7. MALFUNCTION INDICATOR LIGHT CLEAR CONDITION

- When the OK driving cycle is completed 3 times in a row
- When "Clear Memory" is performed

## 8. FAIL SAFE

OFF setting may be needed depending on the NG portion.

## 9. ECM OPERATION AT DTC SETTING

Memorize the freeze frame data. (For test mode \$02)

# Diagnostic Trouble Code (DTC) Detecting Criteria

## GENERAL DESCRIPTION

### AP:DTC P0244 TURBO/SUPER CHARGER WASTEGATE SOLENOID “A” RANGE/PERFORMANCE

#### 1. OUTLINE OF DIAGNOSIS

Detect the malfunction of wastegate control solenoid valve function.  
Judge NG when becoming high wastegate pressure.

#### 2. COMPONENT DESCRIPTION

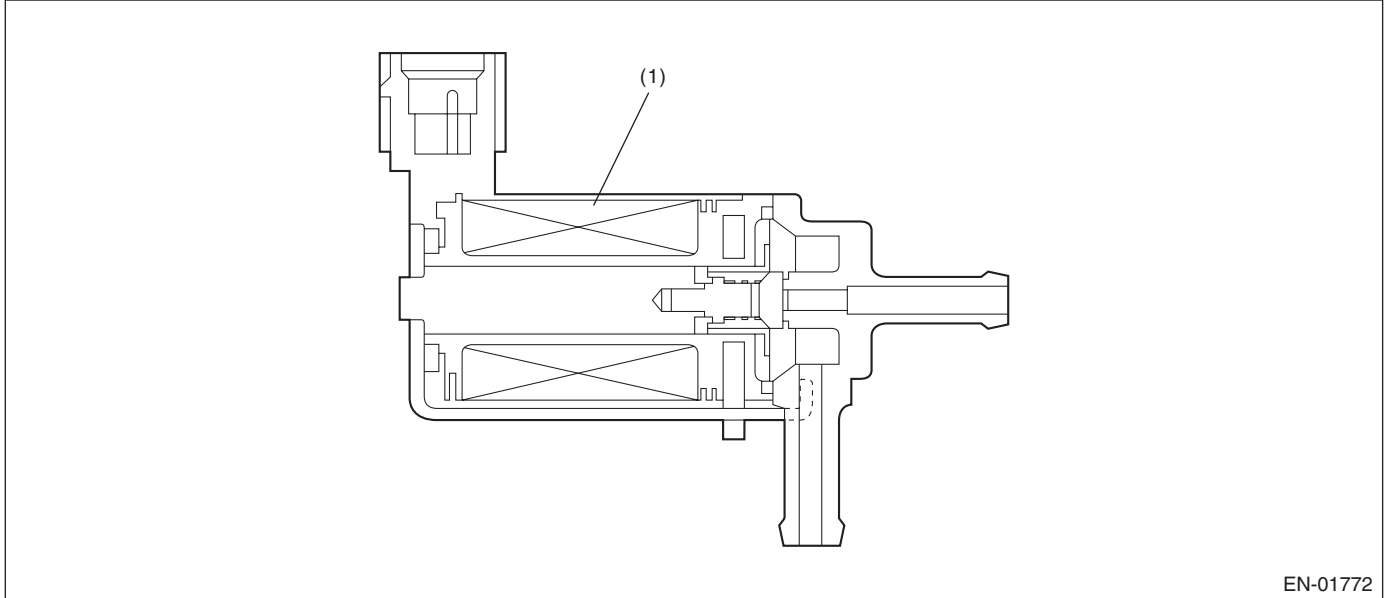

(1) Coil

#### 3. ENABLE CONDITION

Secondary Parameters	Enable Conditions
None	

#### 4. GENERAL DRIVING CYCLE

Always perform the diagnosis continuously.

# Diagnostic Trouble Code (DTC) Detecting Criteria

GENERAL DESCRIPTION

## 5. DIAGNOSTIC METHOD

### Abnormality Judgment

Judge as NG when the continuous time of meeting the malfunction criteria below becomes 1 second or more.

### Judgment Value

Malfunction Criteria	Threshold Value
Intake manifold pressure	≥ Map 10

### Map 10

Atmosphere pressure (kPa (mmHg, inHg))	58.7 (440, 17.3)	67.2 (504, 19.8)	75.7 (568, 22.4)	84.2 (632, 24.9)	92.8 (696, 27.4)	101.3 (760, 29.9)
NG pressure (kPa (mmHg, inHg))	142.4 (1068, 42.1)	156.2 (1172, 46.1)	170.2 (1277, 50.3)	184.1 (1381, 54.4)	198.0 (1485, 58.5)	207.9 (1560, 61.4)
OK pressure (kPa (mmHg, inHg))	120.0 (900, 35.4)	113.8 (1004, 33.6)	147.8 (1109, 43.7)	161.7 (1213, 47.8)	175.6 (1317, 51.9)	185.6 (1392, 54.8)

**Time Needed for Diagnosis:** 1 second

**Malfunction Indicator Light Illumination:** Illuminates as soon as a malfunction occurs.

### Normality Judgment

Judge as OK and clear the NG when the malfunction criteria below are met.

### Judgment Value

Malfunction Criteria	Threshold Value
Intake manifold pressure	< Map 10

## 6. DTC CLEAR CONDITION

- When the OK idling cycle is completed 40 times in a row
- When "Clear Memory" is performed

## 7. MALFUNCTION INDICATOR LIGHT CLEAR CONDITION

- When the OK driving cycle is completed 3 times in a row
- When "Clear Memory" is performed

## 8. FAIL SAFE

None

## 9. ECM OPERATION AT DTC SETTING

Memorize the freeze frame data. (For test mode \$02)

# Diagnostic Trouble Code (DTC) Detecting Criteria

## GENERAL DESCRIPTION

### AQ:DTC P0245 TURBO/SUPER CHARGER WASTEGATE SOLENOID "A" LOW

#### 1. OUTLINE OF DIAGNOSIS

Detect the open or short circuit of wastegate control solenoid valve.

Judge NG when the terminal output voltage remains Low during outputting the duty signal.

#### 2. COMPONENT DESCRIPTION

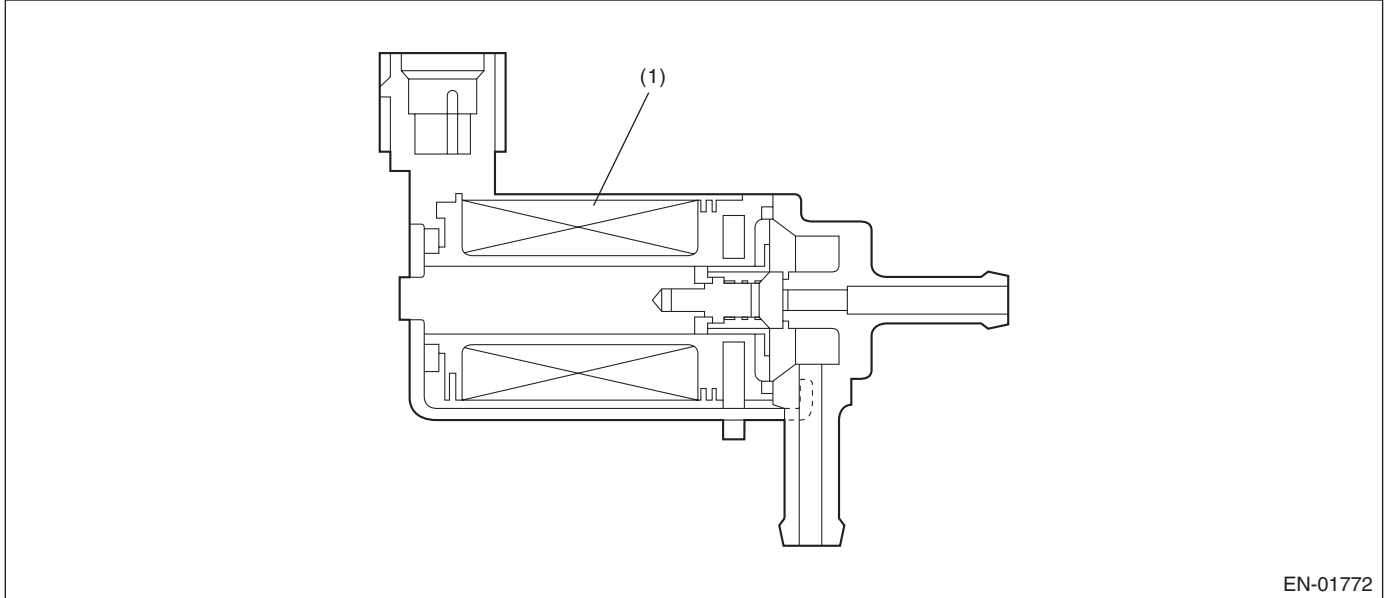

EN-01772

(1) Coil

#### 3. ENABLE CONDITION

Secondary Parameters	Enable Conditions
Battery voltage	> 10.9 V
After engine starting	1 second or more

#### 4. GENERAL DRIVING CYCLE

Perform the diagnosis continuously after starting the engine.



# Diagnostic Trouble Code (DTC) Detecting Criteria

GENERAL DESCRIPTION

## 5. DIAGNOSTIC METHOD

### Abnormality Judgment

Judge NG when the continuous time of meeting the malfunction criteria below becomes more than 655 milliseconds.

### Judgment Value

Malfunction Criteria	Threshold Value
Terminal output	Low
Duty ratio for turbocharged pressure control	< 75%

**Time Needed for Diagnosis:** 655 milliseconds

**Malfunction Indicator Light Illumination:** Illuminates as soon as a malfunction occurs.

### Normality Judgment

Judge as OK and clear the NG when the malfunction criteria below are met.

### Judgment Value

Malfunction Criteria	Threshold Value
Terminal output voltage	High

## 6. DTC CLEAR CONDITION

- When the OK idling cycle is completed 40 times in a row
- When "Clear Memory" is performed

## 7. MALFUNCTION INDICATOR LIGHT CLEAR CONDITION

- When the OK driving cycle is completed 3 times in a row
- When "Clear Memory" is performed

## 8. FAIL SAFE

None

## 9. ECM OPERATION AT DTC SETTING

Memorize the freeze frame data. (For test mode \$02)

# Diagnostic Trouble Code (DTC) Detecting Criteria

## GENERAL DESCRIPTION

### AR:DTC P0246 TURBO/SUPER CHARGER WASTEGATE SOLENOID "A" HIGH

#### 1. OUTLINE OF DIAGNOSIS

Detect the open or short circuit of wastegate control solenoid valve.

Judge NG when the terminal output voltage remains High during outputting the duty signal.

#### 2. COMPONENT DESCRIPTION

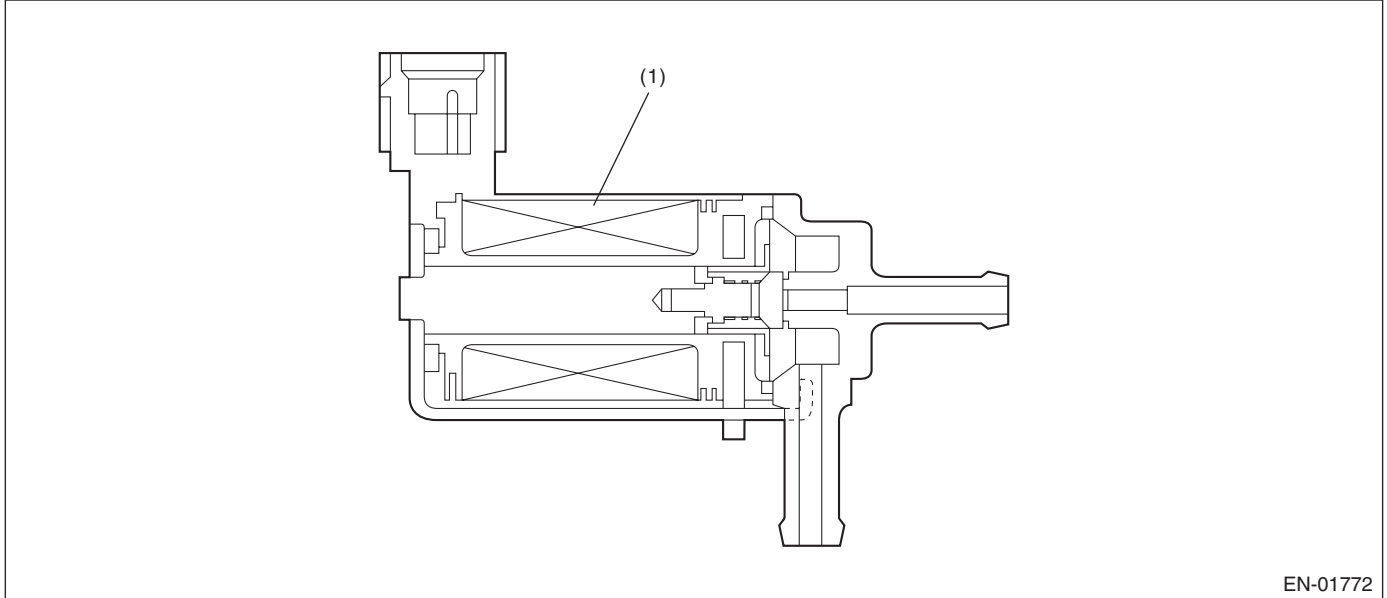

(1) Coil

#### 3. ENABLE CONDITION

Secondary Parameters	Enable Conditions
Battery voltage	> 10.9 V
After engine starting	1 second or more

#### 4. GENERAL DRIVING CYCLE

Perform the diagnosis continuously after starting the engine.

# Diagnostic Trouble Code (DTC) Detecting Criteria

GENERAL DESCRIPTION

## 5. DIAGNOSTIC METHOD

### Abnormality Judgment

Judge NG when the continuous time of meeting the malfunction criteria below becomes more than 655 milliseconds.

### Judgment Value

Malfunction Criteria	Threshold Value
Terminal output	High
Duty ratio for turbocharged pressure control	> 25%

**Time Needed for Diagnosis:** 655 milliseconds

**Malfunction Indicator Light Illumination:** Illuminates as soon as a malfunction occurs.

### Normality Judgment

Judge as OK and clear the NG when the malfunction criteria below are met.

### Judgment Value

Malfunction Criteria	Threshold Value
Terminal output voltage	Low

## 6. DTC CLEAR CONDITION

- When the OK idling cycle is completed 40 times in a row
- When "Clear Memory" is performed

## 7. MALFUNCTION INDICATOR LIGHT CLEAR CONDITION

- When the OK driving cycle is completed 3 times in a row
- When "Clear Memory" is performed

## 8. FAIL SAFE

None

## 9. ECM OPERATION AT DTC SETTING

Memorize the freeze frame data. (For test mode \$02)

# Diagnostic Trouble Code (DTC) Detecting Criteria

## GENERAL DESCRIPTION

### AS:DTC P0301 CYLINDER 1 MISFIRE DETECTED

#### 1. OUTLINE OF DIAGNOSIS

Detect the presence of misfire occurrence. (Revolution fluctuation method)

Monitoring misfire which influences exhaust deterioration (1.5 times of FTP) and catalyst damage is made obligatory by the law. Misfire affecting these two has two patterns below.

- Intermittent misfire (The same cylinder misfires in random, or different cylinders misfire in random.): FTP 1.5 times misfire
- Every time misfire (The same cylinder misfires every time.): FTP 1.5 times misfire, Catalyst damage misfire

The following detecting methods are adopted for these detection.

1) Intermittent misfire: FTP 1.5 times misfire

- 180° Interval Difference Method (MT: 1,800 rpm or less; AT: None)
- 360° Interval Difference Method (whole range)
- 720° Interval Difference Method (3,000 rpm or more)

2) Misfire every time: FTP 1.5 times misfire, Catalyst damage misfire

- 360° Interval Difference Method

#### 2. ENABLE CONDITION

Secondary Parameters	Enable Conditions
Time for keep completing all secondary parameters	1 second or more
Intake manifold pressure change during 0.5 engine revs.	< 13.3 kPa (100 mmHg, 3.93 inHg (MT model)) < 13.3 kPa (100 mmHg, 3.93 inHg (AT model))
Engine speed change	< 1,000 rpm/32 milliseconds
Throttle position change during 16 milliseconds	< 14°
Fuel shut-off function	Not in operation
Atmosphere pressure	≥ 75.0 kPa (563 mmHg, 22.2 inHg)
Fuel level	≥ 9 ℓ (2.38 US gal, 1.98 Imp gal)
Evaporative system leak check	Not in operation
Engine speed	500 — 6500 rpm
Intake manifold pressure	> Value of map 3 or more
Battery voltage	≥ 8 V

#### Map 3

##### MT model

##### Vehicle Speed < 64.4 km/h (40 MPH)

rpm	700	1000	1500	2000	2500	3000	3500	4000	4500	5000	5500	6000	6500	6700
kPa	25.1	24.8	23.3	24.7	24.0	25.6	28.8	30.0	31.6	32.5	37.1	41.9	36.9	51.1
(mmHg, inHg)	(188, 7.40)	(186, 7.32)	(175, 6.89)	(185, 7.30)	(180, 7.09)	(192, 7.56)	(216, 8.51)	(225, 8.86)	(237, 9.33)	(244, 9.60)	(278, 10.96)	(314, 12.4)	(352, 10.90)	(383, 15.1)

##### Vehicle Speed ≥ 64.4 km/h (40 MPH)

rpm	700	1000	1500	2000	2500	3000	3500	4000	4500	5000	5500	6000	6500	6700
kPa	25.1	24.8	23.3	24.7	24.0	25.6	28.8	30.0	31.6	32.5	37.1	41.9	36.9	51.1
(mmHg, inHg)	(188, 7.40)	(186, 7.32)	(175, 6.89)	(185, 7.30)	(180, 7.09)	(192, 7.56)	(216, 8.51)	(225, 8.86)	(237, 9.33)	(244, 9.60)	(278, 10.96)	(314, 12.4)	(352, 10.90)	(383, 15.1)

##### AT model

rpm	700	1000	1500	2000	2500	3000	3500	4000	4500	5000	5500	6000	6500	6700
kPa	26.3	24.7	23.6	26.7	27.3	26.1	29.5	31.3	32.7	34.1	38.2	44.0	49.5	53.3
(mmHg, inHg)	(197, 7.76)	(185, 7.28)	(177, 6.97)	(200, 7.89)	(205, 8.07)	(196, 7.72)	(221.5, 8.72)	(235, 9.25)	(245.5, 9.67)	(256, 10.08)	(286.5, 11.28)	(330, 13.0)	(371.5, 14.63)	(400, 15.74)

# Diagnostic Trouble Code (DTC) Detecting Criteria

GENERAL DESCRIPTION

## 3. GENERAL DRIVING CYCLE

- If conditions are met, detect misfire from idling to high rotation.
- Perform the diagnosis continuously.

## 4. DIAGNOSTIC METHOD

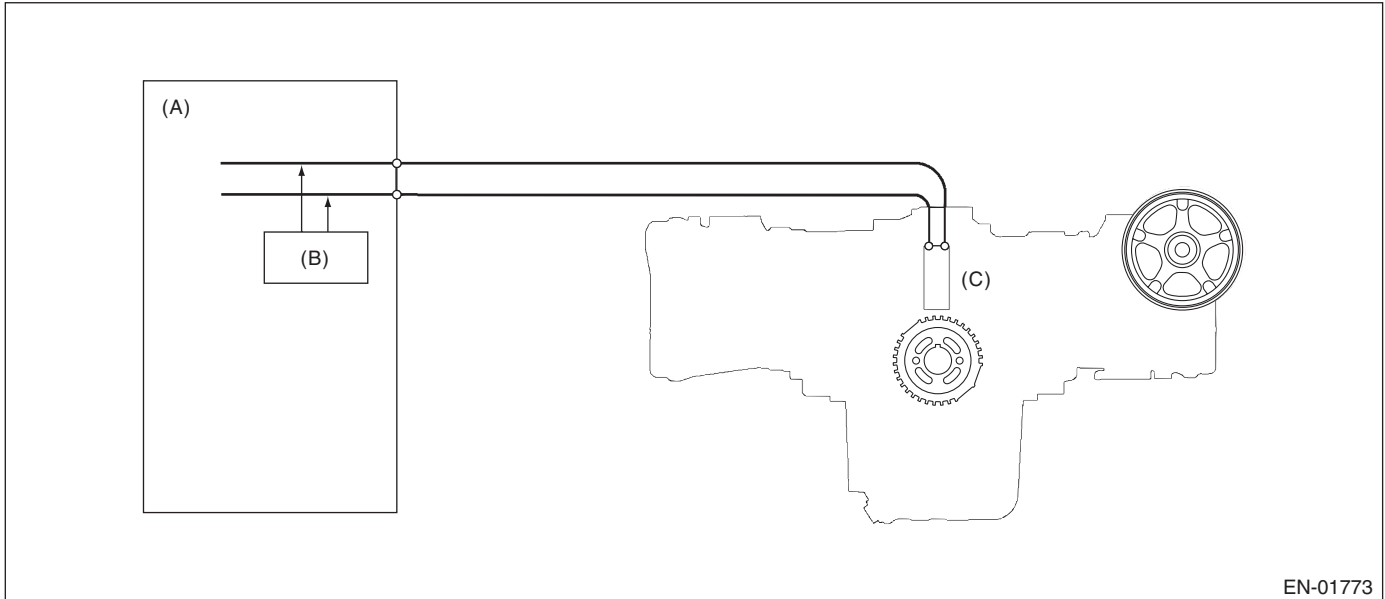

EN-01773

- (A) Engine control module (ECM)
- (B) Diagnosis circuit
- (C) Crankshaft position sensor

When a misfire occurs, the engine speed will decreased and the crankshaft position speed will change. Calculate the interval difference value (diagnostic value) from crankshaft position speed by the following formula, and judge whether a misfire is occurring or not comparing the calculated result with judgment value. Counting the number of misfires, if the misfire ratio is higher during 1000 rev. or 200 rev., Judge corresponding cylinders as NG.

Diagnostic value calculation (Calculate from angle speed) →	Misfire detection every single ignition (Compare diagnostic value with judgment value) →	NG judgment (Misfire occurrence judgment required by the law) (Compare number of misfire with judgment)
	<ul style="list-style-type: none"> <li>• 180° Interval Method</li> <li>• 360° Interval Method</li> <li>• 720° Interval Method</li> </ul>	<ul style="list-style-type: none"> <li>• FTP 1.5 times misfire NG judgment</li> <li>• Catalyst damage misfire NG judgment</li> </ul>

# Diagnostic Trouble Code (DTC) Detecting Criteria

## GENERAL DESCRIPTION

As shown in the following figure, pick a cylinder as the standard and name it omg 0. And the former crankshaft position speed is named omg 1, the second former crankshaft position speed is named omg 2, the third is named omg 3, etc.

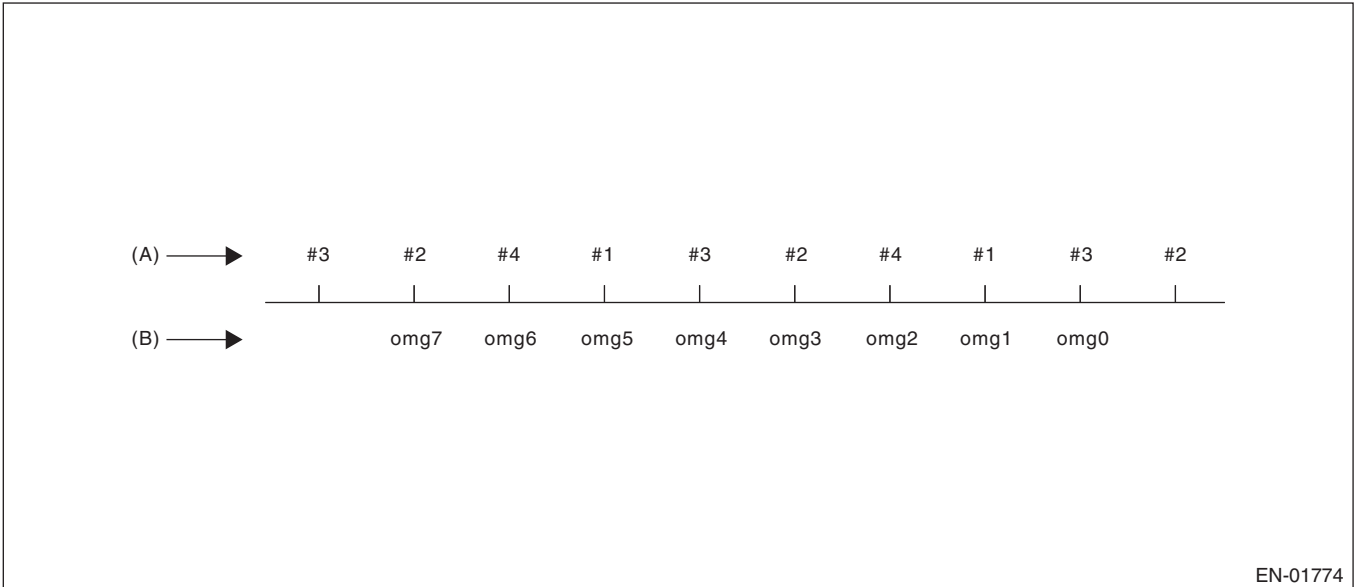

EN-01774

(A) Ignition order

(B) Crankshaft position speed

## 180° Interval Difference Method

Diagnostic value  $domg\ 180 = (omg\ 1 - omg\ 0) - (omg\ 7 - omg\ 1)/6$

Judge as a misfire in the following cases.

- $domg\ 180 >$  judgment value of positive side
  - $domg\ 180 \leq$  judgment value of negative side
- (Judgment value before 180°CA)

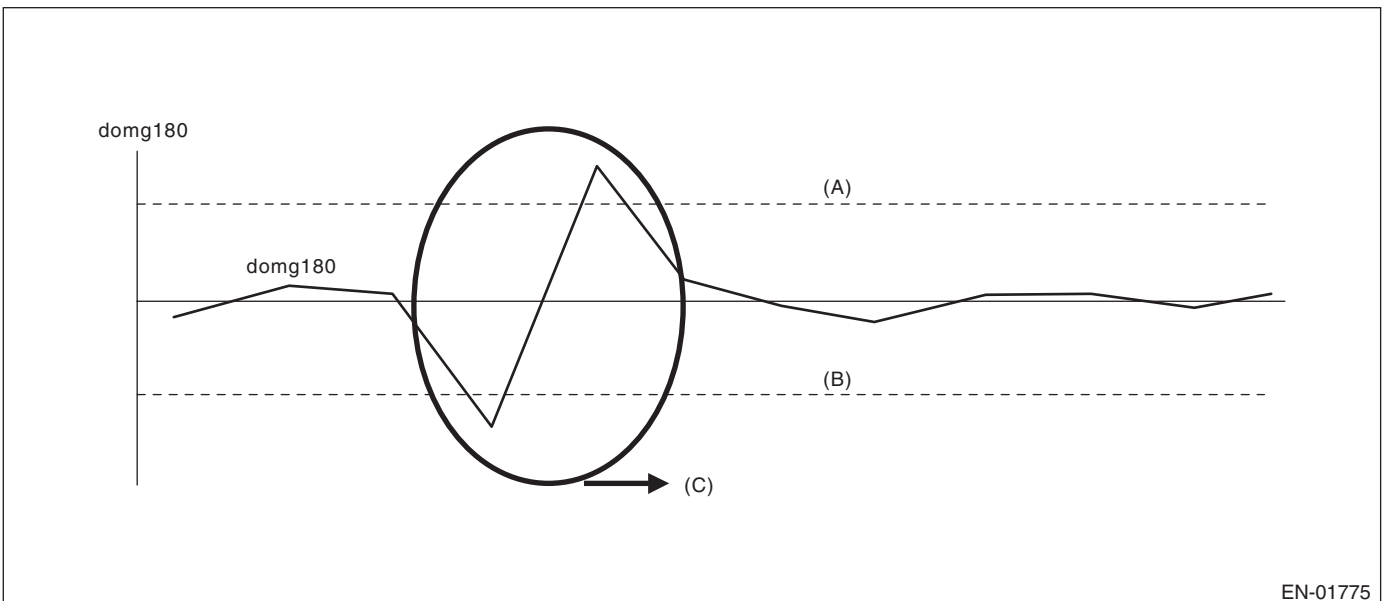

EN-01775

(A) Threshold value (judgment value of the positive side)

(B) Threshold value (judgment value of the negative side)

(C) Judged as a misfire

# Diagnostic Trouble Code (DTC) Detecting Criteria

GENERAL DESCRIPTION

## 360° Interval Difference Method

Diagnostic value	$\text{domg } 360 = (\text{omg } 1 - \text{omg } 0) - (\text{omg } 4 - \text{omg } 3)$
Misfire judgment	$\text{domg } 360 > \text{Judgment value} \rightarrow \text{Judge as misfire}$

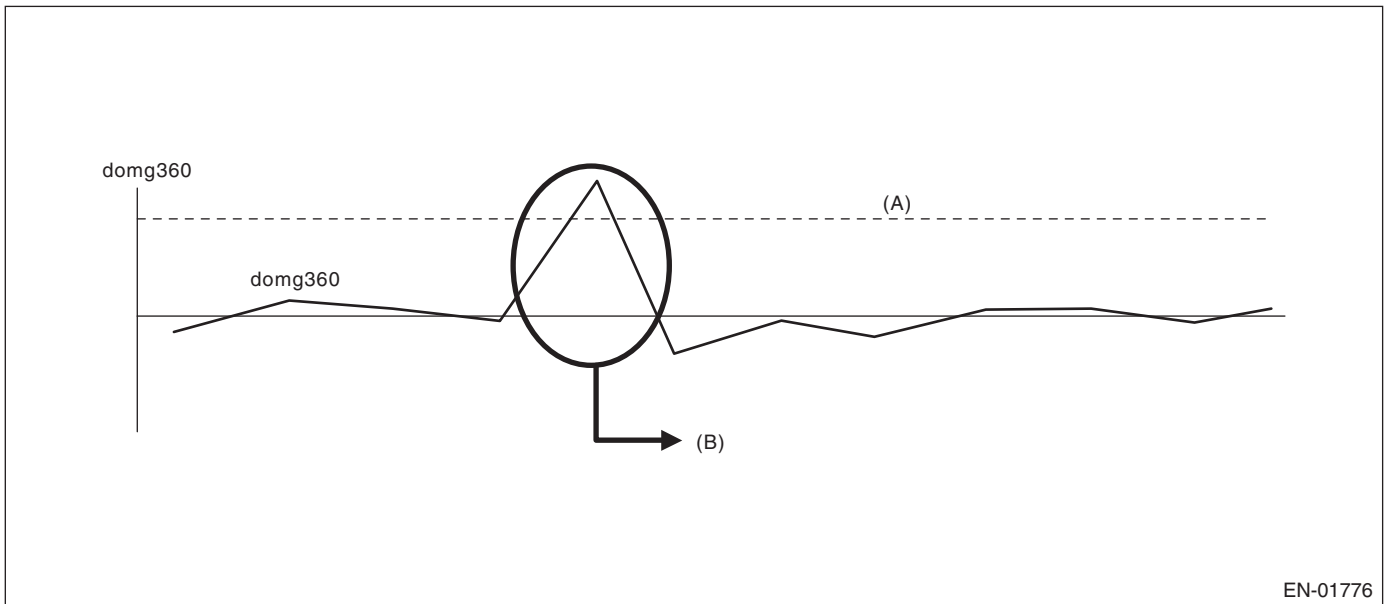

- (A) Threshold value
- (B) Judged as a misfire

## 720° Interval Difference Method

Diagnostic value	$\text{domg } 720 = (\text{omg } 1 - \text{omg } 0) - (\text{omg } 7 - \text{omg } 6)$
Misfire judgment	$\text{domg } 720 > \text{Judgment value} \rightarrow \text{Judge as misfire}$

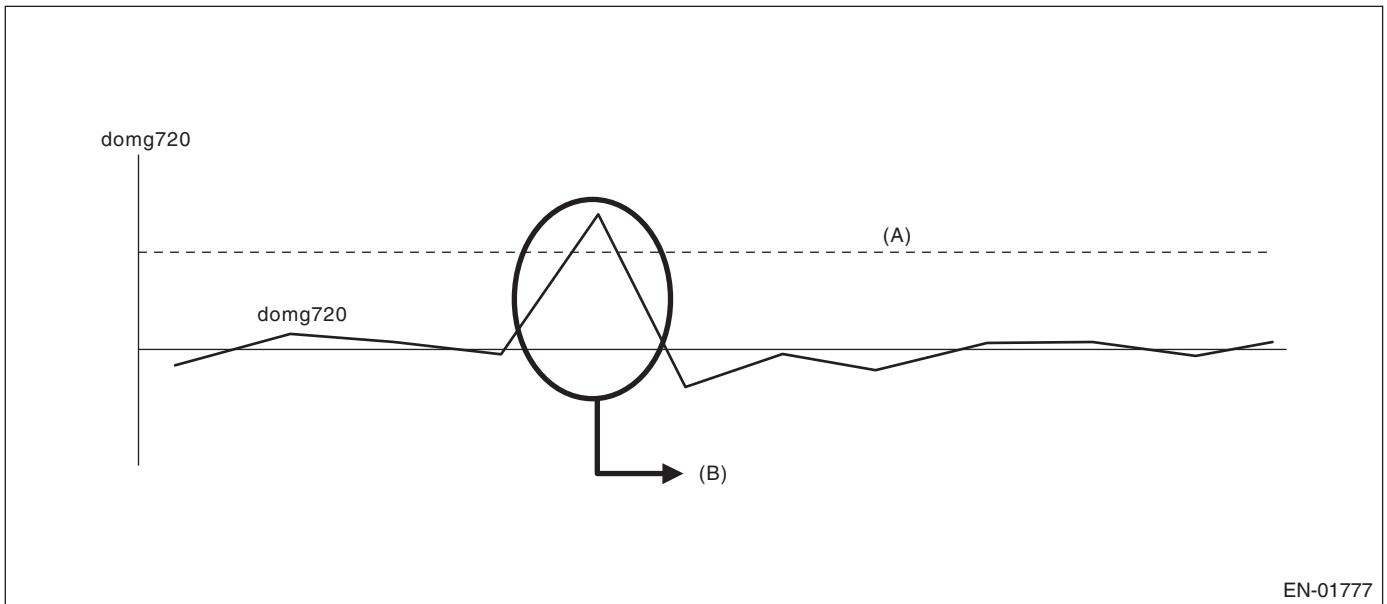

- (A) Threshold value
- (B) Judged as a misfire

# Diagnostic Trouble Code (DTC) Detecting Criteria

## GENERAL DESCRIPTION

### FTP 1.5 times misfire (Misfire occurrence level which influences exhaust gas)

**Judgment Value (Judge that malfunction occurs when the misfire ratio is high in 1000 engine revs.)**

Malfunction Criteria	Threshold Value
FTP emission diagnostic value	> 1.0 % in 1000 revs.

**Time Needed for Diagnosis:** 1000 revs.

**Malfunction Indicator Light Illumination:** Illuminates when malfunction occurs in 2 continuous driving cycles.

### Catalyst damage misfire (Misfire occurrence level damaging catalyst)

**Judgment Value (Judge that malfunction occurs when the misfire ratio is high in 200 engine revs. (400 ignitions))**

Malfunction Criteria	Threshold Value
Catalyst damage misfire judgment value	See Map 1

### Map 1 Fault criteria threshold for misfire which would result in catalyst damage

%	AIR INTAKE (g/rev.)										
	0.2	0.4	0.6	0.8	1.0	1.2	1.4	1.6	1.8	2.0	
ENGINE SPEED (rpm)	1000	37.0	32.0	28.5	26.0	23.0	21.3	21.3	-	-	-
	1500	35.0	29.5	25.5	22.5	21.3	21.3	21.3	18.0	-	-
	2000	32.0	22.5	22.5	18.3	14.5	10.8	10.0	9.0	8.0	5.0
	2500	29.0	21.8	14.3	11.3	9.8	9.0	8.5	8.0	7.5	5.0
	3000	27.0	21.8	14.5	9.8	9.0	9.0	8.0	7.5	7.0	5.0
	3500	24.5	18.5	10.8	6.8	5.8	5.5	5.0	5.0	5.0	5.0
	4000	-	15.3	10.0	6.8	5.5	5.0	5.0	5.0	5.0	5.0
	4500	-	13.8	8.5	6.3	5.0	5.0	5.0	5.0	5.0	-
	5000	-	13.8	8.5	5.8	5.0	5.0	5.0	5.0	5.0	-
	5500	-	13.5	8.3	5.5	5.0	5.0	5.0	5.0	5.0	-
	6000	-	13.0	8.0	5.3	5.0	5.0	5.0	5.0	5.0	-
	6500	-	12.5	7.5	5.0	5.0	5.0	5.0	5.0	-	-
	6700	-	12.3	7.3	5.0	5.0	5.0	5.0	5.0	-	-

EN-02282

These figures indicate the misfire rate (%) in 400 ignitions; for example, 22.5 (%) means 400 (ignition) × 22.5 (%) = 90 (ignition) misfires. This value or more is judged as a misfire.

**Time Needed for Diagnosis:** 200 revs.

**Malfunction Indicator Light Illumination:** Illuminates as soon as a malfunction occurs.

## 5. DTC CLEAR CONDITION

- When the OK idling cycle is completed 40 times in a row
- When "Clear Memory" is performed

## 6. MALFUNCTION INDICATOR LIGHT CLEAR CONDITION

- When a similar driving cycle is established 3 times in a row
- When "Clear Memory" is performed



# Diagnostic Trouble Code (DTC) Detecting Criteria

GENERAL DESCRIPTION

---

## 7. FAIL SAFE

None

## 8. ECM OPERATION AT DTC SETTING

Memorize the freeze frame data. (For test mode \$02)

### **AT:DTC P0302 CYLINDER 2 MISFIRE DETECTED**

NOTE:

For the diagnostic procedure, refer to DTC P0301. <Ref. to GD(H4DOTC)-100, DTC P0301 CYLINDER 1 MISFIRE DETECTED, Diagnostic Trouble Code (DTC) Detecting Criteria.>

### **AU:DTC P0303 CYLINDER 3 MISFIRE DETECTED**

NOTE:

For the diagnostic procedure, refer to DTC P0301. <Ref. to GD(H4DOTC)-100, DTC P0301 CYLINDER 1 MISFIRE DETECTED, Diagnostic Trouble Code (DTC) Detecting Criteria.>

### **AV:DTC P0304 CYLINDER 4 MISFIRE DETECTED**

NOTE:

For the diagnostic procedure, refer to DTC P0301. <Ref. to GD(H4DOTC)-100, DTC P0301 CYLINDER 1 MISFIRE DETECTED, Diagnostic Trouble Code (DTC) Detecting Criteria.>

# Diagnostic Trouble Code (DTC) Detecting Criteria

## GENERAL DESCRIPTION

### AW:DTC P0327 KNOCK SENSOR 1 CIRCUIT LOW (BANK 1 OR SINGLE SENSOR)

#### 1. OUTLINE OF DIAGNOSIS

Detect the open or short circuit of knock sensor.  
Judge as NG if it is out of specification.

#### 2. COMPONENT DESCRIPTION

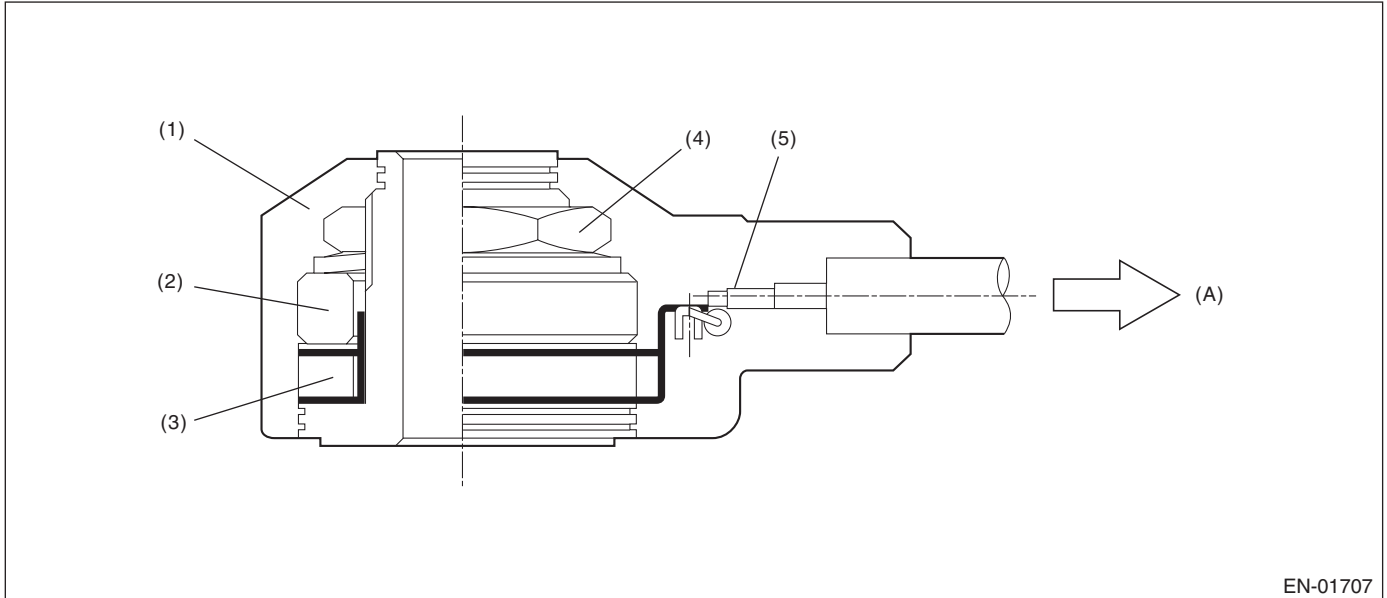

- (1) Case
- (2) Weight
- (3) Piezoelectric element
- (4) Nut
- (5) Resistance

(A) To knock sensor harness

#### 3. ENABLE CONDITION

Secondary Parameters	Enable Conditions
None	

#### 4. GENERAL DRIVING CYCLE

Always perform the diagnosis continuously.

# Diagnostic Trouble Code (DTC) Detecting Criteria

GENERAL DESCRIPTION

## 5. DIAGNOSTIC METHOD

### Abnormality Judgment

Judge as NG when the continuous time of meeting the malfunction criteria below becomes 1 second or more.

### Judgment Value

Malfunction Criteria	Threshold Value
Output voltage	< 0.238 V
Ignition switch	ON

**Time Needed for Diagnosis:** 1 second

**Malfunction Indicator Light Illumination:** Illuminates as soon as a malfunction occurs.

### Normality Judgment

Judge as OK and clear the NG when the malfunction criteria below are met.

### Judgment Value

Malfunction Criteria	Threshold Value
Output voltage	$\geq 0.238$ V
Ignition switch	ON

## 6. DTC CLEAR CONDITION

- When the OK idling cycle is completed 40 times in a row
- When "Clear Memory" is performed

## 7. MALFUNCTION INDICATOR LIGHT CLEAR CONDITION

- When the OK driving cycle is completed 3 times in a row
- When "Clear Memory" is performed

## 8. FAIL SAFE

Knock compensation:

- Knock compensation final advance/delay angle value = knock compensation value + whole learning compensation value + portional learning compensation value
- When normal: Knock compensation value = Fixed at 0°C.A.
- Failure: Knock compensation value = -5°C.A. (5°C.A retard)
- Whole learning compensation coefficient update not allowed.
- Portional learning zone compensation value calculation not allowed.

## 9. ECM OPERATION AT DTC SETTING

Memorize the freeze frame data. (For test mode \$02)

# Diagnostic Trouble Code (DTC) Detecting Criteria

## GENERAL DESCRIPTION

### AX:DTC P0328 KNOCK SENSOR 1 CIRCUIT HIGH (BANK 1 OR SINGLE SENSOR)

#### 1. OUTLINE OF DIAGNOSIS

Detect the open or short circuit of knock sensor.  
Judge as NG if it is out of specification.

#### 2. COMPONENT DESCRIPTION

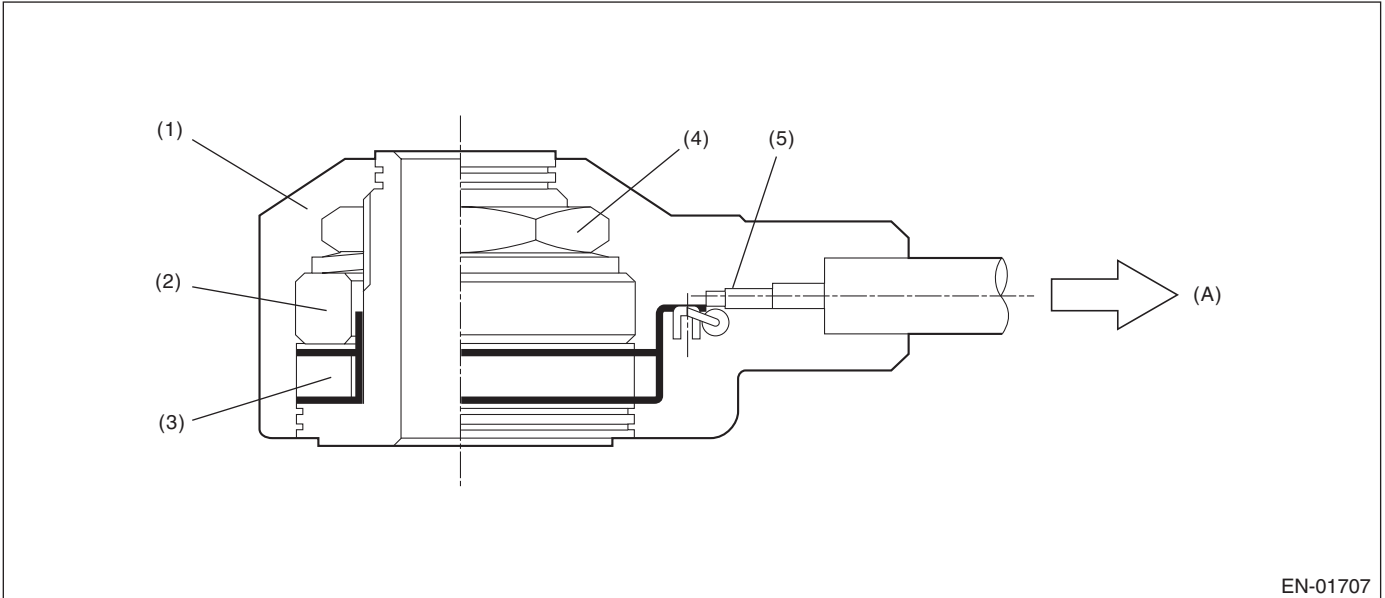

- (1) Case
- (2) Weight
- (3) Piezoelectric element
- (4) Nut
- (5) Resistance

(A) To knock sensor harness

#### 3. ENABLE CONDITION

Secondary Parameters	Enable Conditions
None	

#### 4. GENERAL DRIVING CYCLE

Always perform the diagnosis continuously.

# Diagnostic Trouble Code (DTC) Detecting Criteria

GENERAL DESCRIPTION

## 5. DIAGNOSTIC METHOD

### Abnormality Judgment

Judge as NG when the continuous time of meeting the malfunction criteria below becomes 1 second or more.

### Judgment Value

Malfunction Criteria	Threshold Value
Output voltage	$\geq 4.714$ V
Ignition switch	ON

**Time Needed for Diagnosis:** 1 second

**Malfunction Indicator Light Illumination:** Illuminates as soon as a malfunction occurs.

### Normality Judgment

Judge as OK and clear the NG when the malfunction criteria below are met.

### Judgment Value

Malfunction Criteria	Threshold Value
Output voltage	$< 4.714$ V
Ignition switch	ON

## 6. DTC CLEAR CONDITION

- When the OK idling cycle is completed 40 times in a row
- When "Clear Memory" is performed

## 7. MALFUNCTION INDICATOR LIGHT CLEAR CONDITION

- When the OK driving cycle is completed 3 times in a row
- When "Clear Memory" is performed

## 8. FAIL SAFE

Knock compensation:

- Knock compensation final advance/delay angle value = knock compensation value + whole learning compensation value + portional learning compensation value
- When normal: Knock compensation value = Fixed at 0°C.A.
- Failure: Knock compensation value = -5°C.A. (5°C.A retard)
- Whole learning compensation coefficient update not allowed.
- Portional learning zone compensation value calculation not allowed.

## 9. ECM OPERATION AT DTC SETTING

Memorize the freeze frame data. (For test mode \$02)

# Diagnostic Trouble Code (DTC) Detecting Criteria

## GENERAL DESCRIPTION

### AY:DTC P0335 CRANKSHAFT POSITION SENSOR "A" CIRCUIT

#### 1. OUTLINE OF DIAGNOSIS

Detect the open or short circuit of the crankshaft position sensor.

Judge as NG when the crank signal is not input even though the starter was turned on.

#### 2. COMPONENT DESCRIPTION

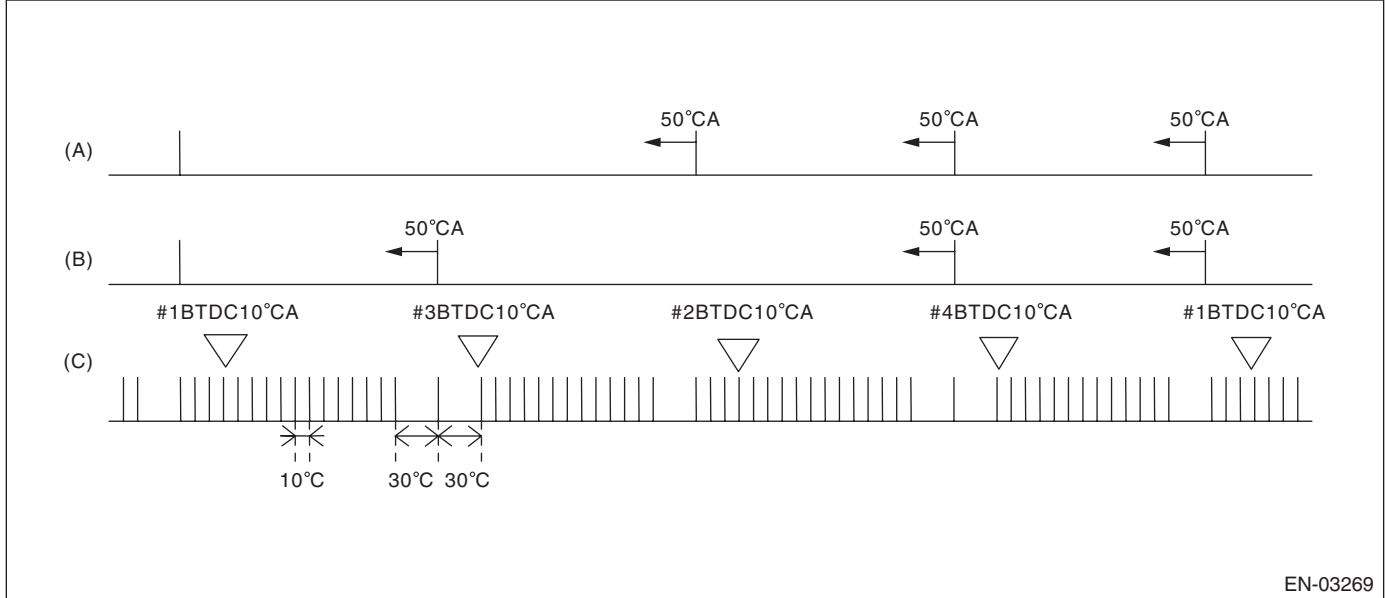

- (A) Camshaft signal (RH)
- (B) Camshaft signal (LH)
- (C) Crankshaft signal

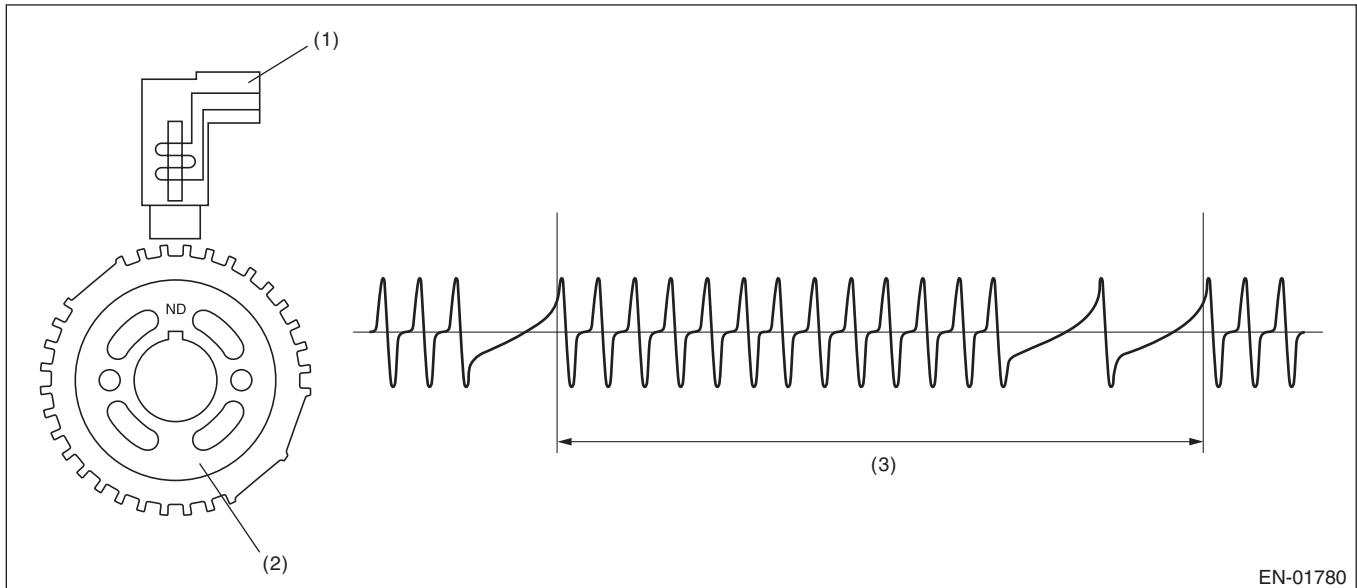

- (1) Crankshaft position sensor
- (2) Crank sprocket
- (3) Crankshaft half-turn

#### 3. ENABLE CONDITION

Secondary Parameters	Enable Conditions
None	

# Diagnostic Trouble Code (DTC) Detecting Criteria

GENERAL DESCRIPTION

## 4. GENERAL DRIVING CYCLE

Always perform the diagnosis continuously.

## 5. DIAGNOSTIC METHOD

### Abnormality Judgment

Judge as NG when the continuous time of meeting the malfunction criteria below becomes more than 3 seconds.

### Judgment Value

Malfunction Criteria	Threshold Value
Starter switch	ON
Crankshaft position sensor signal	Not detected
Battery voltage	$\geq 8 \text{ V}$

**Time Needed for Diagnosis:** 3 seconds

**Malfunction Indicator Light Illumination:** Illuminates as soon as a malfunction occurs.

### Normality Judgment

Judge as OK when the continuous time while meeting the malfunction criteria below is 3 seconds or more.

### Judgment Value

Malfunction Criteria	Threshold Value
Crankshaft position sensor signal	Input exists
Battery voltage	$\geq 8 \text{ V}$

## 6. DTC CLEAR CONDITION

- When the OK idling cycle is completed 40 times in a row
- When "Clear Memory" is performed

## 7. MALFUNCTION INDICATOR LIGHT CLEAR CONDITION

- When the OK driving cycle is completed 3 times in a row
- When "Clear Memory" is performed

## 8. FAIL SAFE

None

## 9. ECM OPERATION AT DTC SETTING

Memorize the freeze frame data. (For test mode \$02)

# Diagnostic Trouble Code (DTC) Detecting Criteria

## GENERAL DESCRIPTION

### AZ:DTC P0336 CRANKSHAFT POSITION SENSOR "A" CIRCUIT RANGE/ PERFORMANCE

#### 1. OUTLINE OF DIAGNOSIS

Detect for faults in crankshaft position sensor output properties.

Judge as NG when there is a problem in the number of crankshaft signals for every revolution.

#### 2. COMPONENT DESCRIPTION

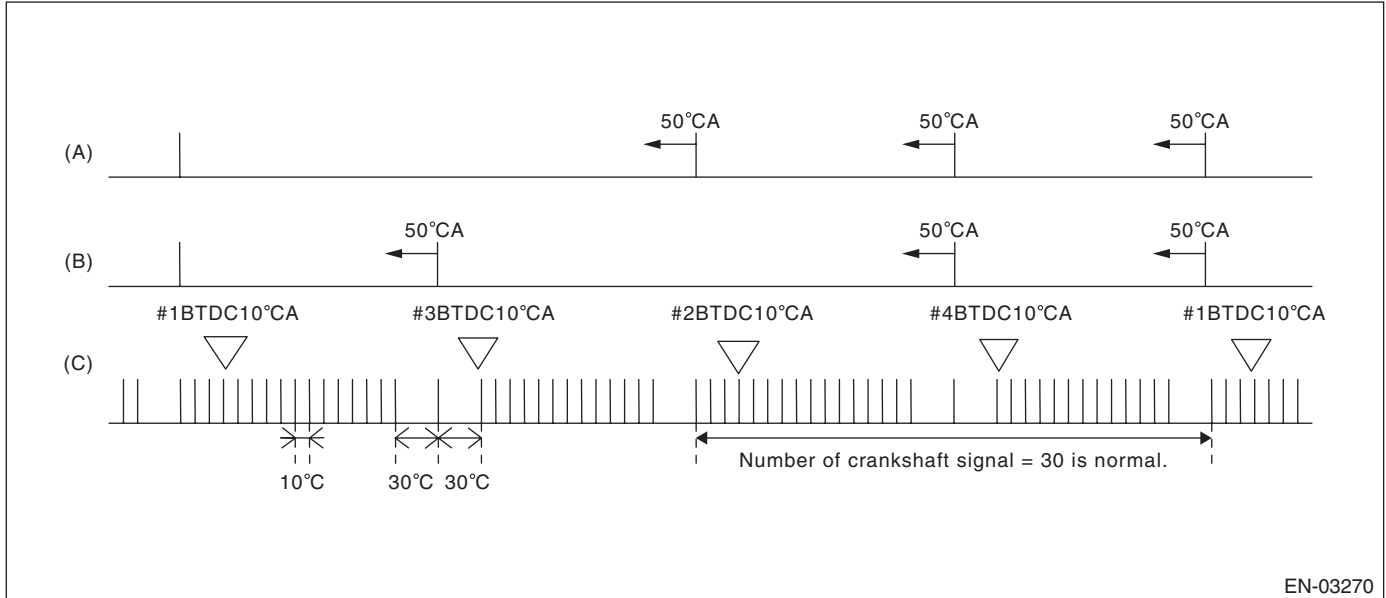

- (A) Camshaft signal (RH)
- (B) Camshaft signal (LH)
- (C) Crankshaft signal

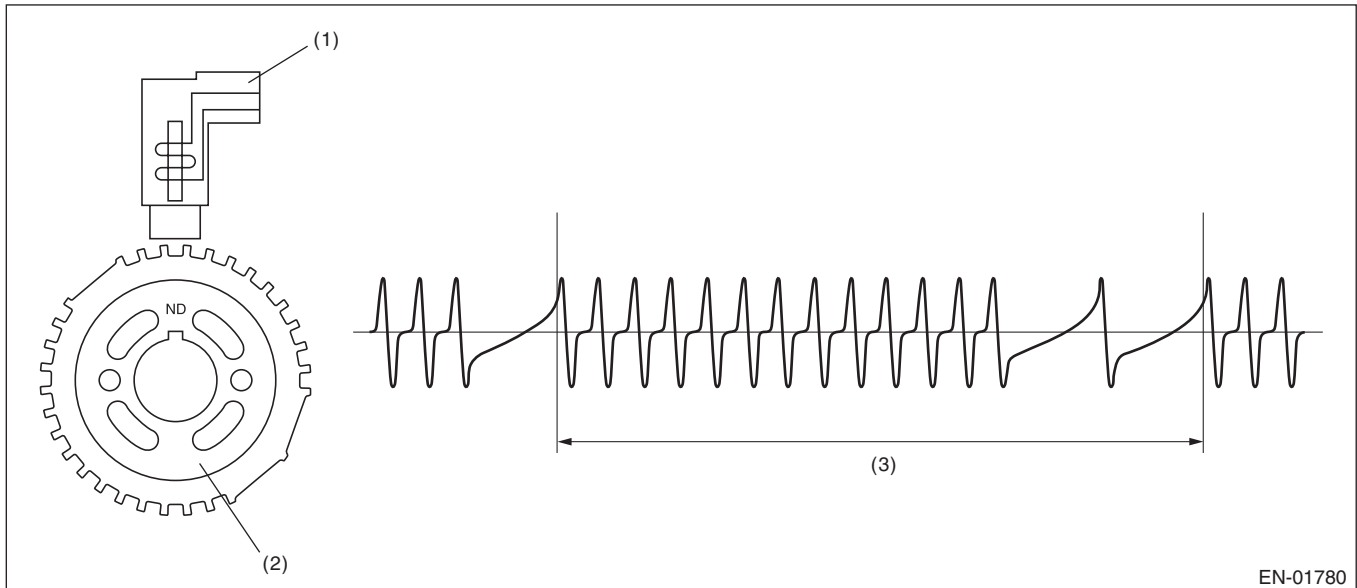

- (1) Crankshaft position sensor
- (2) Crank sprocket
- (3) Crankshaft half-turn



# Diagnostic Trouble Code (DTC) Detecting Criteria

GENERAL DESCRIPTION

## 3. ENABLE CONDITION

Secondary Parameters	Enable Conditions
Battery voltage	$\geq 8$ V
Engine speed	$< 3000$ rpm

## 4. GENERAL DRIVING CYCLE

Perform the diagnosis continuously under 3000 rpm engine speed.

## 5. DIAGNOSTIC METHOD

### Abnormality Judgment

Judge as NG when all the malfunction criteria below are completed more than 10 times in a row.

### Judgment Value

Malfunction Criteria	Threshold Value
Cylinder number identification	Completed
Number of crankshaft position sensor signal during 1 rev.	Not = 30

**Time Needed for Diagnosis:** 10 engine revs.

**Malfunction Indicator Light Illumination:** Illuminates when malfunction occurs in 2 continuous driving cycles.

### Normality Judgment

Judge as OK and clear the NG when all the malfunction criteria below are met.

### Judgment Value

Malfunction Criteria	Threshold Value
Cylinder number distinction	Completed
Number of crankshaft position sensor signal during 1 rev.	= 30

## 6. DTC CLEAR CONDITION

- When the OK idling cycle is completed 40 times in a row
- When "Clear Memory" is performed

## 7. MALFUNCTION INDICATOR LIGHT CLEAR CONDITION

- When the OK driving cycle is completed 3 times in a row
- When "Clear Memory" is performed

## 8. FAIL SAFE

None

## 9. ECM OPERATION AT DTC SETTING

Memorize the freeze frame data. (For test mode \$02)

# Diagnostic Trouble Code (DTC) Detecting Criteria

## GENERAL DESCRIPTION

### BA:DTC P0340 CAMSHAFT POSITION SENSOR "A" CIRCUIT (BANK 1 OR SINGLE SENSOR)

#### 1. OUTLINE OF DIAGNOSIS

Detect the open or short circuit of the camshaft position sensor.  
Judge as NG when the number of camshaft signals remains abnormal.

#### 2. COMPONENT DESCRIPTION

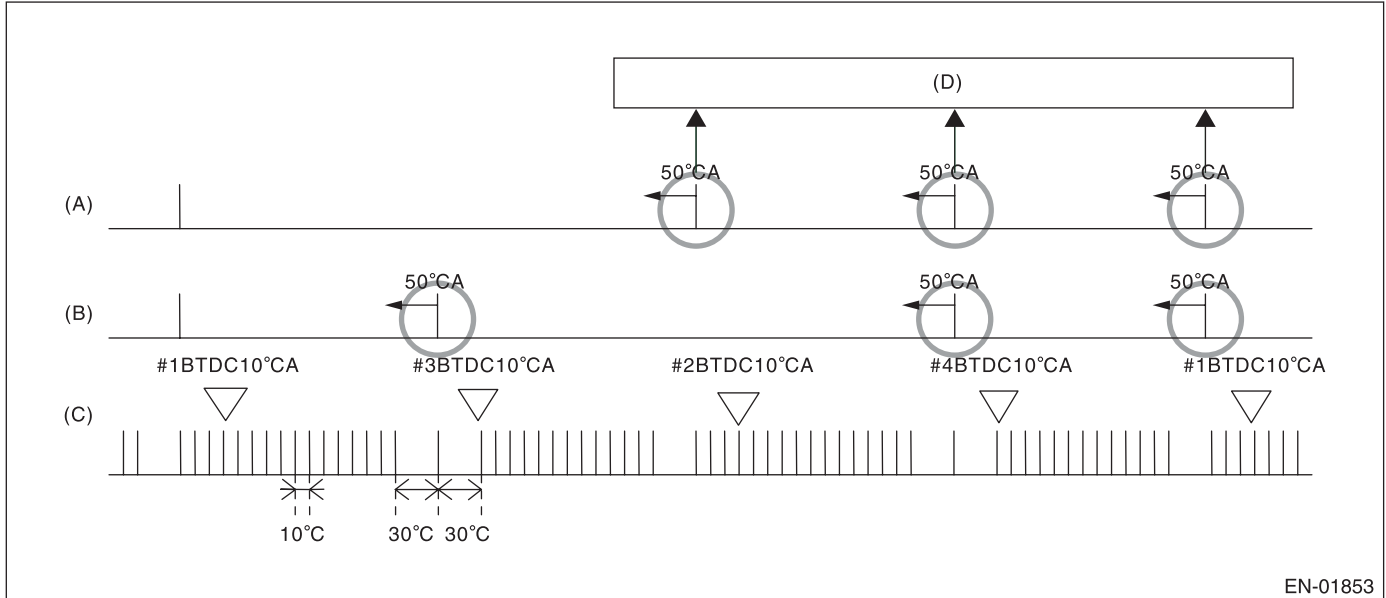

EN-01853

- (A) Camshaft signal (RH)
- (B) Camshaft signal (LH)
- (C) Crankshaft signal
- (D) Number of camshaft position signals = When normal, there will be 3 cam signals for every 2 engine revolutions.

#### 3. ENABLE CONDITION

Secondary Parameters	Enable Conditions
Voltage	≥ 8 V

#### 4. GENERAL DRIVING CYCLE

Always perform the diagnosis continuously.

# Diagnostic Trouble Code (DTC) Detecting Criteria

GENERAL DESCRIPTION

## 5. DIAGNOSTIC METHOD

### Abnormality Judgment

When normal, there should be 3 cam signals per 2 engine revolutions. If a condition where it is not 3 times continues, It is judged as NG.

When the engine speed is over 100 rpm, if the following conditions are established it is judged as NG. Judge as OK and clear the NG when the following criteria are not established.

### Judgment Value

Malfunction Criteria	Threshold Value
Number of camshaft sensor signals during 2 revs.	Not = 3
Engine speed	≥ 600 rpm

**Time Needed for Diagnosis:** 100 revs.

**Malfunction Indicator Light Illumination:** Illuminates as soon as a malfunction occurs.

### Normality Judgment

Judge as OK and clear the NG when the following criteria are established.

### Judgment Value

Malfunction Criteria	Threshold Value
Number of camshaft angle sensor signals during 2 revs.	3

## 6. DTC CLEAR CONDITION

- When the OK idling cycle is completed 40 times in a row
- When "Clear Memory" is performed

## 7. MALFUNCTION INDICATOR LIGHT CLEAR CONDITION

- When the OK driving cycle is completed 3 times in a row
- When "Clear Memory" is performed

## 8. FAIL SAFE

- Ignition timing whole learning compensation:
  - Enter the initial value (whole learning compensation factor = 0.5, Variable amount of whole learning compensation factor = 0.25) to the whole learning compensation factor and variable amount of whole learning compensation factor when IG OFF, and then make the whole learning incomplete.
  - Enter the initial value (whole learning compensation factor = 0.5, Variable amount of whole learning compensation factor = 0.25) to the whole learning compensation factor and variable amount of whole learning compensation factor when making a normality judgment from abnormality judgment, and then make the whole learning incomplete.
- Ignition timing partial learning compensation:
  - Enter the initial value (0°CA) to the compensation value of partial learning zone with IG OFF.
  - Enter the initial value (0°CA) to the compensation value of the partial learning zone when making a normality judgment → abnormality judgment.
- AVCS control:
  - Maximum timing retard learning is not complete or maximum timing retard learning completion is not experienced.
  - ⇒ ISC feedback compensation: Do not perform the AVCS actual timing advance compensation.
  - Make the OCV driving Duty to be the given value (9.36%).

## 9. ECM OPERATION AT DTC SETTING

Memorize the freeze frame data. (For test mode \$02)

### BB:DTC P0345 CAMSHAFT POSITION SENSOR "A" CIRCUIT (BANK 2)

NOTE:

For diagnostic procedure, refer to DTC P0340. <Ref. to GD(H4DOTC)-114, DTC P0340 CAMSHAFT POSITION SENSOR "A" CIRCUIT (BANK 1 OR SINGLE SENSOR), Diagnostic Trouble Code (DTC) Detecting Criteria.>

# Diagnostic Trouble Code (DTC) Detecting Criteria

## GENERAL DESCRIPTION

---

### BC:DTC P0410 SECONDARY AIR INJECTION SYSTEM

#### 1. OUTLINE OF DIAGNOSIS

Detect NG of the secondary air supply pipe pressure, secondary air supply pipe pressure pulse, and secondary air piping flow.

#### 2. ENABLE CONDITION

Secondary Parameters	Enable Conditions
Estimate ambient temperature	4.4°C (39.92°F)
Battery voltage	7 V
Atmosphere pressure	563 mmHg
Engine	In operation
Pump supply pressure check	
Amount of intake air	≥ 2 g (0.07 oz)/sec.
Secondary air pump	In operation
Combination valve	One bank is open. (Except when both banks are open.)
Pulse check with one combination valve closed	
Diagnosable range	≥ 1 (Refer to Map10)
After fuel cut	≥ 500 milliseconds
Pulse check with both combination valves closed	
Engine load	≥ 0.2 g (0.007 oz)/rev
After fuel cut	≥ 500 milliseconds
Pressure check when switching combination valve	
Amount of intake air	≥ 2 g (0.07 oz)/sec. and ≤ 20 g (0.7 oz)/sec.
Engine speed	< 4000 rpm
After fuel cut	≥ 500 milliseconds

#### 3. GENERAL DRIVING CYCLE

Perform diagnosis while secondary pump is operating

## 4. DIAGNOSTIC METHOD

Measure secondary air supply pipe pressure, secondary air supply pipe pressure pulse, and secondary air piping flow.

### **Pump supply pressure check**

Perform the functional diagnosis of the system by checking the increased pressure value when the secondary air pump is ON in relation to the pressure value when the pump is OFF.

### **Pulse check with one combination valve closed**

When the right combination valve is closed, perform diagnosis of the left combination valve for stuck closed by supply piping pressure pulse.

When the left combination valve is closed, perform diagnosis of the right combination valve for stuck closed by supply piping pressure pulse.

### **Pulse check with both combination valves closed**

When both left and right combination valves are closed, perform the diagnosis of both left and right combination valves for stuck opened by supply pipe pressure pulse. Determine which valve is stuck opened by comparing secondary air flow rate with right combination valve closed and secondary air flow rate with left combination valve closed.

### **Pressure check when switching combination valve**

When the right combination valve is switched from closed position to open position, perform the diagnosis of the right combination valve for the stuck closed by change of the supply pipe pressure.

When the left combination valve is switched from open position to closed position, perform the diagnosis of the left combination valve for the stuck closed by change of the supply pipe pressure.

### **Check for excessive air flow**

Perform the diagnosis of the secondary air system for air flow error by the secondary air flow rate with the right combination valve closed and secondary air flow rate with the left combination valve closed.

# Diagnostic Trouble Code (DTC) Detecting Criteria

## GENERAL DESCRIPTION

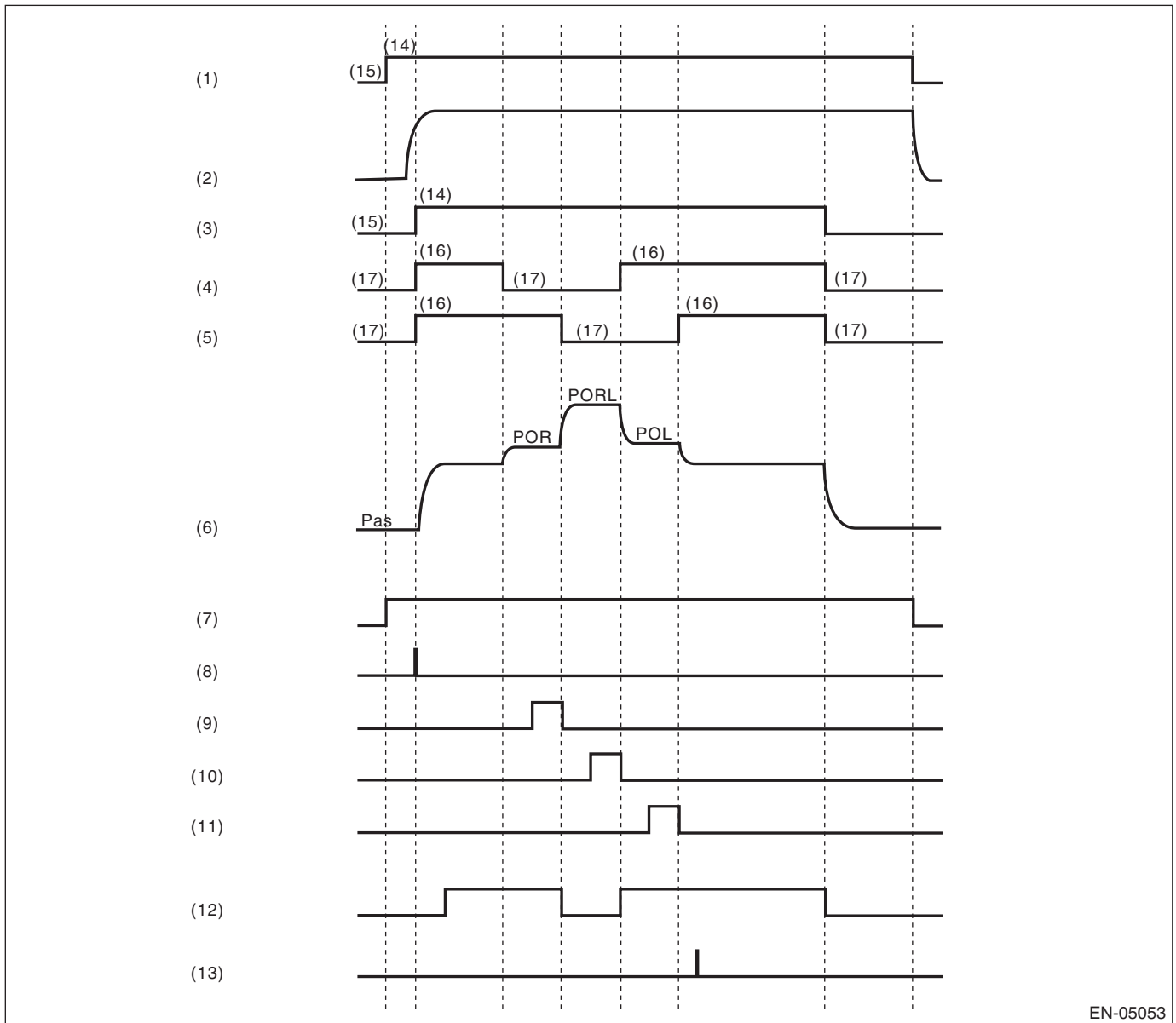

EN-05053

- |  |   |  |
|--|---|--|
| (1) IG   | (8) Atmospheric pressure before secondary air control (Pas) measurement | (12) Pump supply pressure check (judgment) |
| (2) Ne   | (9) Right bank shut off pressure (POR) measurement                      | (13) Flow amount check (judgment)          |
| (3) Secondary air pump drive condition         | (10) Both bank shut off pressure (PURL) measurement                     | (14) ON                                    |
| (4) E-COMB valve (Right) condition             | (11) Left bank shut off pressure (POL) measurement                      | (15) OFF                                   |
| (5) E-COMB valve (Left) condition              |   | (16) Open                                  |
| (6) Secondary air supply piping pressure (psi) |   | (17) Close                                 |
| (7) Diagnosis execution conditions             |   |  |

# Diagnostic Trouble Code (DTC) Detecting Criteria

GENERAL DESCRIPTION

## Judgment Value

### Pump supply pressure check

When the secondary air pump is switched from OFF to ON, the pump supply pressure should increase. Judge as NG when the pressure does not increase.

If the following conditions are met, judge as NG. If the following conditions are not met, judge as OK, and clear the NG.

Malfunction Criteria	Threshold Value	DTC
Secondary air supply pipe pressure (after atmospheric pressure compensation)	< 1 kPa (7 mmHg, 0.3 inHg)	P0410

### Pulse check with one combination valve closed

Calculate the voltage pulse of the pump supply piping pressure when the right combination valve is closed and left combination valve is open. The integrated value should be large because the left combination valve is open and there are pulses of the pump supply piping pressure. If the value is small, diagnose the left combination valve as stuck closed.

If the following conditions are met, judge as NG. If the following conditions are not met, judge as OK, and clear the NG.

Malfunction Criteria	Threshold Value	DTC
Integrated value of pulse when the right combination valve is closed	< Value of Map 1	P2443

Calculate the voltage pulse of the pump supply piping pressure when the left combination valve is closed and right combination valve is open. The integrated value should be large because the right combination valve is open and there are pulses of the pump supply piping pressure. If the value is small, diagnose the right combination valve as stuck closed.

If the following conditions are met, judge as NG. If the following conditions are not met, judge as OK, and clear the NG.

Malfunction Criteria	Threshold Value	DTC
Integrated value of pulse when the left combination valve is closed	< Value of Map 2	P2441

### Pulse check with both combination valves closed

Calculate the voltage pulse of the pump supply piping pressure when both left and right combination valves are closed. The integrated value should be small because both combination valves are closed and there are no pulse of supply piping pressure. If the integrated value is large, diagnose either of left or right combination valves as stuck open.

Determine which valve is stuck opened by comparing secondary air flow rate with right combination valve closed and secondary air flow rate with left combination valve closed. The flow rate of combination valve that is stuck open will be high.

If the following conditions are met, judge as NG. If the following conditions are not met, judge as OK, and clear the NG.

Malfunction Criteria	Threshold Value	DTC
Integrated value of pulse when both left and right combination valves are closed	> Value of Map 3	P2440
Flow rate when the right bank is closed (value of Map 4)	≥ Flow rate when the left bank is closed (value of Map 5)	
Integrated value of pulse when both left and right combination valves are closed	> Map 3	P2442
Flow rate when the left bank is closed (value of Map 5)	> Flow rate when the right bank is closed (value of Map 4)	

## Diagnostic Trouble Code (DTC) Detecting Criteria

### GENERAL DESCRIPTION

#### Pressure check when switching combination valve

When the left combination valve is switched from open position to closed position, the supply pipe pressure should change. If the value change little, diagnose the left combination valve as stuck closed.

If the following conditions are met, judge as NG. If the following conditions are not met, judge as OK, and clear the NG.

Malfunction Criteria	Threshold Value	DTC
Changed value when the left combination valve is switched	< Value of Map 6	P2443

When the right combination valve is switched from closed position to open position, the supply pipe pressure should change. If the value change little, diagnose the right combination valve as stuck closed.

If the following conditions are met, judge as NG. If the following conditions are not met, judge as OK, and clear the NG.

Malfunction Criteria	Threshold Value	DTC
Changed value when the right combination valve is switched	< Value of Map 7	P2441

#### Check for excessive air flow

If the secondary air flow rate when the right combination valve is closed, or the secondary air flow rate when the left combination valve is closed becomes too large, diagnose as secondary air system air flow error.

Malfunction Criteria	Threshold Value	DTC
Flow rate when the right bank is closed (value of Map 4) or Flow rate when the left bank is closed (value of Map 4)	> Map 8  > Map 9	P0411
Voltage when PORL is measured – voltage when POR is measured	≤ 4 V	
Voltage when PORL is measured – voltage when POL is measured	≤ 4 V	

PORL: Both bank shut off pressure  
 POR: Right bank shut off pressure  
 POL: Left bank shut off pressure



# Diagnostic Trouble Code (DTC) Detecting Criteria

GENERAL DESCRIPTION

## Map 1

Engine speed (rpm) Amount of intake air (g (oz)/s)	1000	1500	2000	2100	4000
15 (0.53)	2	2	2	1.04	1.04
20 (0.71)	2	2	2	1.04	1.04
25 (0.88)	2	2	2	1.04	1.04
30 (1.06)	1.04	2	1.6	1.04	1.04
35 (1.23)	1.04	1.8	1.3	1.04	1.04
(V)					

## Map 2

Engine speed (rpm) Amount of intake air (g (oz)/s)	1000	1500	2000	2100	4000
15 (0.53)	2	2	2	1.04	1.04
20 (0.71)	2	2	2	1.04	1.04
25 (0.88)	2	2	2	1.04	1.04
30 (1.06)	1.04	1.04	1.04	1.04	1.04
35 (1.23)	1.04	1.04	1.04	1.04	1.04
(V)					

## Map 3

Intake air (g (oz)/rev)	0.1 (0.004 )	0.3 (0.011 )	0.35 (0.012 )	1 (0.04)
Threshold value (V)	12	12	4	4

# Diagnostic Trouble Code (DTC) Detecting Criteria

## GENERAL DESCRIPTION

### Map 4

Secondary air pressure in the pipe when both comb. valve is closing kPa (mmHg, inHg) Secondary air pressure in the pipe when LH comb. valve is closing kPa (mmHg, inHg)	69.3 (520, 20.47)	74.7 (560, 22.06)	80.0 (600, 23.63)	85.3 (640, 25.19)	90.7 (680, 26.79)	96.0 (720, 28.35)	101.3 (760, 29.92)	106.7 (800, 31.51)	112.0 (840, 33.08)	117.3 (880, 34.64)	122.7 (920, 36.24)	128.0 (960, 37.80)	133.3 (1000, 39.37)	138.7 (1040, 40.96)	144.0 (1080, 42.53)	149.3 (1120, 44.09)
69.3 (520, 20.47)	0	200	400	600	800	1000	1200	1400	1600	1800	2000	2200	2400	2400	2400	2400
74.7 (560, 22.06)	-200	0	200	400	600	800	1000	1200	1400	1600	1800	2000	2200	2400	2400	2400
80.0 (600, 23.63)	-400	-200	0	200	400	600	800	1000	1200	1400	1600	1800	2000	2200	2400	2400
85.3 (640, 25.19)	-600	-400	-200	0	200	400	600	800	1000	1200	1400	1600	1800	2000	2200	2400
90.7 (680, 26.79)	-800	-600	-400	-200	0	200	400	600	800	1000	1200	1400	1600	1800	2000	2200
96.0 (720, 28.35)	-1000	-800	-600	-400	-200	0	200	400	600	800	1000	1200	1400	1600	1800	2000
101.3 (760, 29.92)	-1200	-1000	-800	-600	-400	-200	0	200	400	600	800	1000	1200	1400	1600	1800
106.7 (800, 31.51)	-1400	-1200	-1000	-800	-600	-400	-200	0	200	400	600	800	1000	1200	1400	1600
112.0 (840, 33.08)	-1600	-1400	-1200	-1000	-800	-600	-400	-200	0	200	400	600	800	1000	1200	1400
117.3 (880, 34.64)	-1800	-1600	-1400	-1200	-1000	-800	-600	-400	-200	0	200	400	600	800	1000	1200
122.7 (920, 36.24)	-2000	-1800	-1600	-1400	-1200	-1000	-800	-600	-400	-200	0	200	400	600	800	1000
128.0 (960, 37.80)	-2200	-2000	-1800	-1600	-1400	-1200	-1000	-800	-600	-400	-200	0	200	400	600	800
133.3 (1000, 39.37)	-2400	-2200	-2000	-1800	-1600	-1400	-1200	-1000	-800	-600	-400	-200	0	200	400	600
138.7 (1040, 40.96)	-2400	-2400	-2200	-2000	-1800	-1600	-1400	-1200	-1000	-800	-600	-400	-200	0	200	400
144.0 (1080, 42.53)	-2400	-2400	-2400	-2200	-2000	-1800	-1600	-1400	-1200	-1000	-800	-600	-400	-200	0	200
149.3 (1120, 44.09)	-2400	-2400	-2400	-2400	-2200	-2000	-1800	-1600	-1400	-1200	-1000	-800	-600	-400	-200	0
(L/min)																

# Diagnostic Trouble Code (DTC) Detecting Criteria

GENERAL DESCRIPTION

## Map 5

Secondary air pressure in the pipe when both comb. valve is closing kPa (mmHg, inHg) Secondary air pressure in the pipe when RH comb. valve is closing kPa (mmHg, inHg)	69.3 (520, 20.47)	74.7 (560, 22.06)	80.0 (600, 23.63)	85.3 (640, 25.19)	90.7 (680, 26.79)	96.0 (720, 28.35)	101.3 (760, 29.92)	106.7 (800, 31.51)	112.0 (840, 33.08)	117.3 (880, 34.64)	122.7 (920, 36.24)	128.0 (960, 37.80)	133.3 (1000, 39.37)	138.7 (1040, 40.96)	144.0 (1080, 42.53)	149.3 (1120, 44.09)
69.3 (520, 20.47)	0	200	400	600	800	1000	1200	1400	1600	1800	2000	2200	2400	2400	2400	2400
74.7 (560, 22.06)	-200	0	200	400	600	800	1000	1200	1400	1600	1800	2000	2200	2400	2400	2400
80.0 (600, 23.63)	-400	-200	0	200	400	600	800	1000	1200	1400	1600	1800	2000	2200	2400	2400
85.3 (640, 25.19)	-600	-400	-200	0	200	400	600	800	1000	1200	1400	1600	1800	2000	2200	2400
90.7 (680, 26.79)	-800	-600	-400	-200	0	200	400	600	800	1000	1200	1400	1600	1800	2000	2200
96.0 (720, 28.35)	-1000	-800	-600	-400	-200	0	200	400	600	800	1000	1200	1400	1600	1800	2000
101.3 (760, 29.92)	-1200	-1000	-800	-600	-400	-200	0	200	400	600	800	1000	1200	1400	1600	1800
106.7 (800, 31.51)	-1400	-1200	-1000	-800	-600	-400	-200	0	200	400	600	800	1000	1200	1400	1600
112.0 (840, 33.08)	-1600	-1400	-1200	-1000	-800	-600	-400	-200	0	200	400	600	800	1000	1200	1400
117.3 (880, 34.64)	-1800	-1600	-1400	-1200	-1000	-800	-600	-400	-200	0	200	400	600	800	1000	1200
122.7 (920, 36.24)	-2000	-1800	-1600	-1400	-1200	-1000	-800	-600	-400	-200	0	200	400	600	800	1000
128.0 (960, 37.80)	-2200	-2000	-1800	-1600	-1400	-1200	-1000	-800	-600	-400	-200	0	200	400	600	800
133.3 (1000, 39.37)	-2400	-2200	-2000	-1800	-1600	-1400	-1200	-1000	-800	-600	-400	-200	0	200	400	600
138.7 (1040, 40.96)	-2400	-2400	-2200	-2000	-1800	-1600	-1400	-1200	-1000	-800	-600	-400	-200	0	200	400
144.0 (1080, 42.53)	-2400	-2400	-2400	-2200	-2000	-1800	-1600	-1400	-1200	-1000	-800	-600	-400	-200	0	200
149.3 (1120, 44.09)	-2400	-2400	-2400	-2400	-2200	-2000	-1800	-1600	-1400	-1200	-1000	-800	-600	-400	-200	0

(L/min)

# Diagnostic Trouble Code (DTC) Detecting Criteria

## GENERAL DESCRIPTION

### Map 6

Amount of intake air when LH comb. valve switches (g (oz)/s) Battery voltage when LH comb. valve switches (V)	10 (0.35)	12.5 (0.441)	15 (0.53)	17.5 (0.617)	20 (0.71)
11	0.05	0.05	0.04	0.03	0.03
12	0.05	0.05	0.05	0.05	0.04
13	0.05	0.05	0.05	0.05	0.05
14	0.05	0.05	0.05	0.05	0.05
(V)					

### Map 7

Amount of intake air when RH comb. valve switches (g (oz)/s) Battery voltage when RH comb. valve switches (V)	10 (0.35)	12.5 (0.441)	15 (0.53)	17.5 (0.617)	20 (0.71)
11	0.05	0.05	0.04	0.03	0.03
12	0.05	0.05	0.05	0.05	0.04
13	0.05	0.05	0.05	0.05	0.05
14	0.05	0.05	0.05	0.05	0.05
(V)					

### Map 8

Amount of intake air when POR is measuring (g (oz)/s) Battery voltage when POR measuring (V)	2 (0.07)	4 (0.14)	6 (0.21)	8 (0.28)	10 (0.35)	12 (0.42)	14 (0.49)	16 (0.56)	18 (0.63)
10.5	290	290	290	290	290	290	290	290	290
11.5	330	330	330	330	330	330	330	330	330
12.5	370	370	370	370	370	370	370	370	370
13.5	420	420	420	420	420	420	420	420	420
14.5	470	470	470	470	470	470	470	470	470
15.5	520	520	520	520	520	520	520	520	520
(L/min)									

### Map 9

Amount of intake air when POL is measuring (g (oz)/s) Battery voltage when POL measuring (V)	2 (0.07)	4 (0.14)	6 (0.21)	8 (0.28)	10 (0.35)	12 (0.42)	14 (0.49)	16 (0.56)	18 (0.63)
10.5	290	290	290	290	290	290	290	290	290
11.5	330	330	330	330	330	330	330	330	330
12.5	370	370	370	370	370	370	370	370	370
13.5	420	420	420	420	420	420	420	420	420
14.5	470	470	470	470	470	470	470	470	470
15.5	520	520	520	520	520	520	520	520	520
(L/min)									

# Diagnostic Trouble Code (DTC) Detecting Criteria

GENERAL DESCRIPTION

## Map 10

Amount of intake air (g (oz)/s) Engine speed (rpm)	10 (0.35)	15 (0.53)	35 (1.23)	50 (1.76)
500	0	1	1	0
1000	0	1	1	0
4000	0	1	1	0
5000	0	0	0	0

**Time Needed for Diagnosis:** 10 seconds

**Malfunction Indicator Light Illumination:** Illuminates when malfunction occurs in 2 continuous driving cycles.

### 5. DTC CLEAR CONDITION

- When the OK idling cycle is completed 40 times in a row
- When "Clear Memory" is performed

### 6. MALFUNCTION INDICATOR LIGHT CLEAR CONDITION

- When the OK driving cycle is completed 3 times in a row
- When "Clear Memory" is performed

### 7. FAIL SAFE

None

### 8. ECM OPERATION AT DTC SETTING

- Memorize the freeze frame data. (For test mode \$02)
- Memorize the diagnostic value and trouble standard value. (For test mode \$06)

## **BD:DTC P0411 SECONDARY AIR INJECTION SYSTEM INCORRECT FLOW DETECTED**

NOTE:

For the diagnostic procedure, refer to DTC P0410. <Ref. to GD(H4DOTC)-116, DTC P0410 SECONDARY AIR INJECTION SYSTEM, Diagnostic Trouble Code (DTC) Detecting Criteria.>

# Diagnostic Trouble Code (DTC) Detecting Criteria

## GENERAL DESCRIPTION

---

### BE:DTC P0413 SECONDARY AIR INJECTION SYSTEM SWITCHING VALVE "A" CIRCUIT OPEN

#### 1. OUTLINE OF DIAGNOSIS

Judge as NG when the ECM output level differs from the actual terminal level.

#### 2. ENABLE CONDITION

Secondary Parameters	Enable Conditions
None	

#### 3. GENERAL DRIVING CYCLE

Always perform the diagnosis continuously.

#### 4. DIAGNOSTIC METHOD

##### Abnormality Judgment

When the continuous time with following conditions being established exceeds 2.5 seconds, it is judged as NG.

##### Judgment Value

Malfunction Criteria	Threshold Value
Battery voltage	≥ 10.9 V
Ignition	ON
Terminal output voltage when ECM outputs OFF signal	Low

**Time Needed for Diagnosis:** 2.5 seconds

**Malfunction Indicator Light Illumination:** Illuminates as soon as a malfunction occurs.

##### Normality Judgment

Judge as OK when the following conditions are established, and clear the NG.

##### Judgment Value

Malfunction Criteria	Threshold Value
Battery voltage	≥ 10.9 V
Ignition	ON
Terminal output voltage when ECM outputs OFF signal	High

#### 5. DTC CLEAR CONDITION

- When the OK idling cycle is completed 40 times in a row
- When "Clear Memory" is performed

#### 6. MALFUNCTION INDICATOR LIGHT CLEAR CONDITION

- When the OK driving cycle is completed 3 times in a row
- When "Clear Memory" is performed

#### 7. FAIL SAFE

None

#### 8. ECM OPERATION AT DTC SETTING

Memorize the freeze frame data. (For test mode \$02)

# Diagnostic Trouble Code (DTC) Detecting Criteria

GENERAL DESCRIPTION

## BF:DTC P0414 SECONDARY AIR INJECTION SYSTEM SWITCHING VALVE "A" CIRCUIT SHORTED

### 1. OUTLINE OF DIAGNOSIS

Judge as NG when the ECM output level differs from the actual terminal level.

### 2. ENABLE CONDITION

Secondary Parameters	Enable Conditions
None	

### 3. GENERAL DRIVING CYCLE

Always perform the diagnosis continuously.

### 4. DIAGNOSTIC METHOD

#### Abnormality Judgment

When the continuous time with following conditions being established exceeds 2.5 seconds, it is judged as NG.

#### Judgment Value

Malfunction Criteria	Threshold Value
Battery voltage	$\geq 10.9$ V
Ignition	ON
Terminal output voltage when ECM outputs ON signal	High

**Time Needed for Diagnosis:** 2.5 seconds

**Malfunction Indicator Light Illumination:** Illuminates as soon as a malfunction occurs.

#### Normality Judgment

Judge as OK when the following conditions are established, and clear the NG.

#### Judgment Value

Malfunction Criteria	Threshold Value
Battery voltage	$\geq 10.9$ V
Ignition	ON
Terminal output voltage when ECM outputs ON signal	Low

### 5. DTC CLEAR CONDITION

- When the OK idling cycle is completed 40 times in a row
- When "Clear Memory" is performed

### 6. MALFUNCTION INDICATOR LIGHT CLEAR CONDITION

- When the OK driving cycle is completed 3 times in a row
- When "Clear Memory" is performed

### 7. FAIL SAFE

None

### 8. ECM OPERATION AT DTC SETTING

Memorize the freeze frame data. (For test mode \$02)

## Diagnostic Trouble Code (DTC) Detecting Criteria

### GENERAL DESCRIPTION

---

#### **BG:DTC P0416 SECONDARY AIR INJECTION SYSTEM SWITCHING VALVE “B” CIRCUIT OPEN**

**NOTE:**

For the diagnostic procedure, refer to DTC P0413. <Ref. to GD(H4DOTC)-126, DTC P0413 SECONDARY AIR INJECTION SYSTEM SWITCHING VALVE “A” CIRCUIT OPEN, Diagnostic Trouble Code (DTC) Detecting Criteria.>

#### **BH:DTC P0417 SECONDARY AIR INJECTION SYSTEM SWITCHING VALVE “B” CIRCUIT SHORTED**

**NOTE:**

For the diagnostic procedure, refer to DTC P0414. <Ref. to GD(H4DOTC)-127, DTC P0414 SECONDARY AIR INJECTION SYSTEM SWITCHING VALVE “A” CIRCUIT SHORTED, Diagnostic Trouble Code (DTC) Detecting Criteria.>



# Diagnostic Trouble Code (DTC) Detecting Criteria

GENERAL DESCRIPTION

## BI: DTC P0418 SECONDARY AIR INJECTION SYSTEM CONTROL "A" CIRCUIT OPEN

### 1. OUTLINE OF DIAGNOSIS

Judge as NG when the ECM output level differs from the actual terminal level.

### 2. ENABLE CONDITION

Secondary Parameters	Enable Conditions
None	

### 3. GENERAL DRIVING CYCLE

Always perform the diagnosis continuously.

### 4. DIAGNOSTIC METHOD

#### Abnormality Judgment

When the continuous time with following conditions being established exceeds 2.5 seconds, it is judged as NG.

#### Judgment Value

Malfunction Criteria	Threshold Value
Battery voltage	$\geq 10.9$ V
Ignition	ON
Terminal output voltage when ECM outputs OFF signal	Low

**Time Needed for Diagnosis:** 2.5 seconds

**Malfunction Indicator Light Illumination:** Illuminates as soon as a malfunction occurs.

#### Normality Judgment

Judge as OK when the following conditions are established, and clear the NG.

#### Judgment Value

Malfunction Criteria	Threshold Value
Battery voltage	$\geq 10.9$ V
Ignition	ON
Terminal output voltage when ECM outputs OFF signal	High

### 5. DTC CLEAR CONDITION

- When the OK idling cycle is completed 40 times in a row
- When "Clear Memory" is performed

### 6. MALFUNCTION INDICATOR LIGHT CLEAR CONDITION

- When the OK driving cycle is completed 3 times in a row
- When "Clear Memory" is performed

### 7. FAIL SAFE

None

### 8. ECM OPERATION AT DTC SETTING

Memorize the freeze frame data. (For test mode \$02)

# Diagnostic Trouble Code (DTC) Detecting Criteria

## GENERAL DESCRIPTION

### BJ:DTC P0420 CATALYST SYSTEM EFFICIENCY BELOW THRESHOLD (BANK 1)

#### 1. OUTLINE OF DIAGNOSIS

Detect the deterioration of the catalyst function.

Though the rear oxygen sensor output would change slowly with a new catalyst, the sensor output with a deteriorated catalyst becomes high and the inversion time is shortened.

For this reason, the catalyst diagnosis is carried out by monitoring the rear oxygen sensor output and comparing it with the front oxygen A/F sensor output.

#### 2. COMPONENT DESCRIPTION

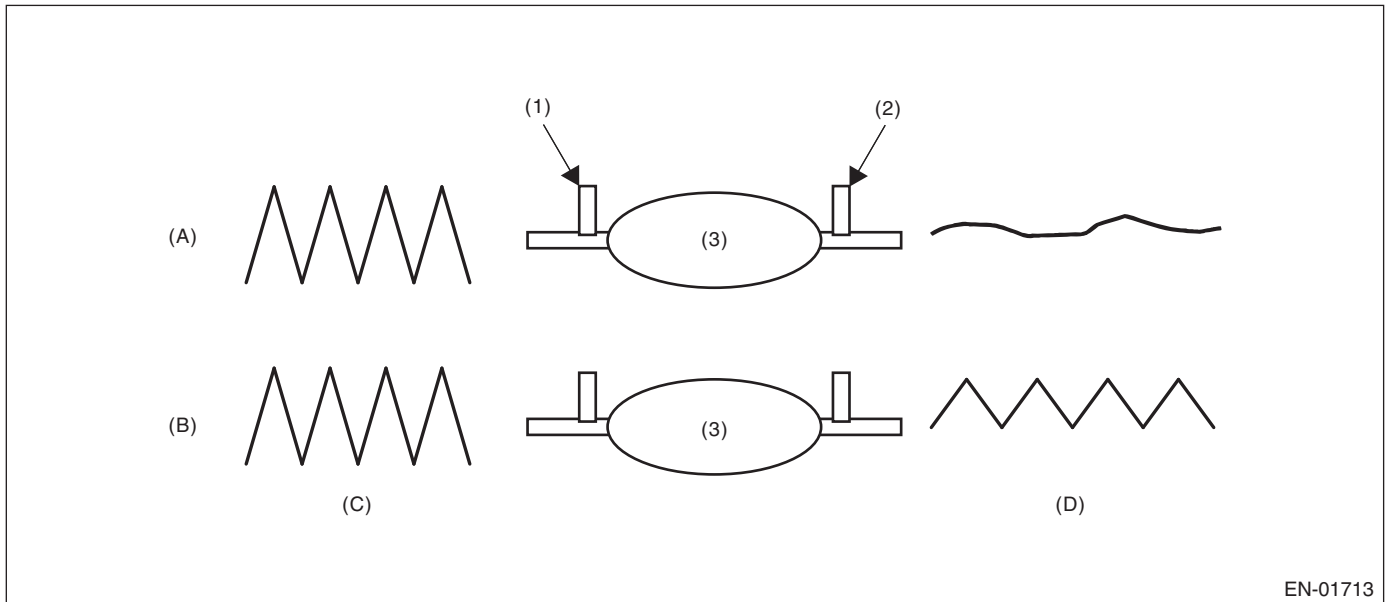

EN-01713

- (1) Front oxygen (A/F) sensor
- (2) Rear oxygen sensor
- (3) Catalytic converter

- (A) Normal
- (B) Deterioration
- (C) Output waveform from the front oxygen (A/F) sensor
- (D) Output waveform from the rear oxygen sensor

#### 3. ENABLE CONDITION

Secondary Parameters	Enable Conditions
Battery voltage	> 10.9 V
Atmosphere pressure	> 75.0 kPa (563 mmHg, 22.2 inHg)
Engine coolant temperature	≥ 70°C (158°F)
Misfire detection during 200 revs.	< 5 times
Learning value of evaporation gas density	< 0.20
Sub feedback	In operation
Evaporative system diagnosis	Not in operation
Time of difference (< 0.10) between actual and target lambda	1000 milliseconds or more
Vehicle speed	≥ 70 km/h (47 MPH)
Amount of intake air	12 — 40 g/s
Engine load change every 0.5 engine revs.	< 0.02 g/rev
Rear oxygen output change from lower than to higher than 600 mV	Experienced after fuel cut
After engine starting	≥ 235 sec.
Accumulative time of canister purge operation after engine starting	≥ 19.9 sec.
Estimated catalyst layer temperature	≥ 580°C (1076°F)

# Diagnostic Trouble Code (DTC) Detecting Criteria

GENERAL DESCRIPTION

## 4. GENERAL DRIVING CYCLE

After warm-up, perform the diagnosis only once at a constant 75 km/h (47 MPH).

## 5. DIAGNOSTIC METHOD

After the execution criterias are established, calculate the output fluctuation value of front oxygen (A/F) sensor and output fluctuation value of rear oxygen sensor. Calculate the diagnosis value when the front oxygen (A/F) sensor output fluctuation value is more than specified value. A/F response properties and diagnosis values are parameters for the judgment value.

Judge as NG when the malfunction criteria below are met. Judge as OK if the criteria below are not met.

### Judgment Value

Malfunction Criteria	Threshold Value
Accumulated variation of rear oxygen sensor output voltage per 32 milliseconds divided by lambda accumulated variation of the front oxygen (A/F) sensor per 32 milliseconds	$\geq 12.6$

**Time Needed for Diagnosis:** 33 — 55 seconds

**Malfunction Indicator Light Illumination:** Illuminates when malfunction occurs in 2 continuous driving cycles.

## 6. DTC CLEAR CONDITION

- When the OK idling cycle is completed 40 times in a row
- When “Clear Memory” is performed

## 7. MALFUNCTION INDICATOR LIGHT CLEAR CONDITION

- When the OK driving cycle is completed 3 times in a row
- When “Clear Memory” is performed

## 8. FAIL SAFE

None

## 9. ECM OPERATION AT DTC SETTING

- Memorize the freeze frame data. (For test mode \$02)
- Memorize the diagnostic value and trouble standard value. (For test mode \$06)

## BK:DTC P0441 EVAPORATIVE EMISSION SYSTEM INCORRECT PURGE FLOW

### NOTE:

For the diagnostic procedure, refer to DTC P0442. <Ref. to GD(H4DOTC)-132, DTC P0442 EVAPORATIVE EMISSION CONTROL SYSTEM LEAK DETECTED (SMALL LEAK), Diagnostic Trouble Code (DTC) Detecting Criteria.>

# Diagnostic Trouble Code (DTC) Detecting Criteria

## GENERAL DESCRIPTION

### BL:DTC P0442 EVAPORATIVE EMISSION CONTROL SYSTEM LEAK DETECTED (SMALL LEAK)

#### 1. OUTLINE OF DIAGNOSIS

Check if there is a leakage in fuel system or not, and perform the function diagnosis of valve.

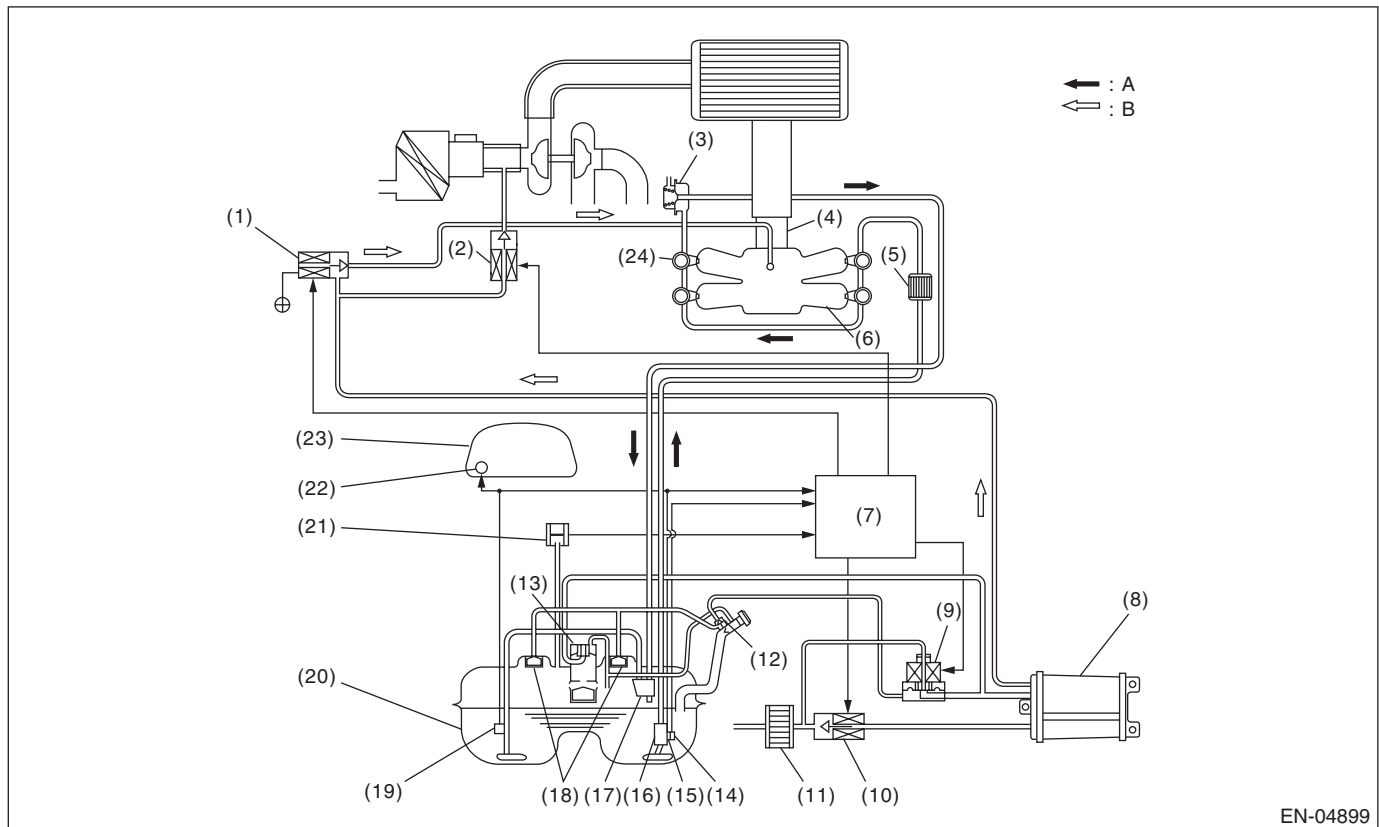

- |                                     |                                |
|-------------------------------------|--------------------------------|
| (1) Purge control solenoid valve    | (14) Fuel temperature sensor   |
| (2) Purge control solenoid valve 2  | (15) Fuel level sensor         |
| (3) Pressure regulator              | (16) Fuel pump                 |
| (4) Throttle body                   | (17) Jet pump                  |
| (5) Fuel filter                     | (18) Fuel cut valve            |
| (6) Intake manifold                 | (19) Fuel sub level sensor     |
| (7) Engine control module (ECM)     | (20) Fuel tank                 |
| (8) Canister                        | (21) Fuel tank pressure sensor |
| (9) Pressure control solenoid valve | (22) Fuel gauge                |
| (10) Drain valve                    | (23) Combination meter         |
| (11) Drain filter                   | (24) Fuel injector             |
| (12) Shut-off valve                 | (A) Fuel line                  |
| (13) Vent valve                     | (B) Vaporized fuel line        |

In this system diagnosis, check for leakage and valve function is conducted by changing the fuel tank pressure and monitoring the pressure change using the fuel tank pressure sensor. When in 0.04 inch diagnosis, perform in the order of mode Z → mode A → mode B → mode C and mode D; When in 0.02 inch diagnosis, perform in the order of mode A → mode B → mode C → mode D and mode E.

# Diagnostic Trouble Code (DTC) Detecting Criteria

GENERAL DESCRIPTION

## 0.04-INCH DIAGNOSIS

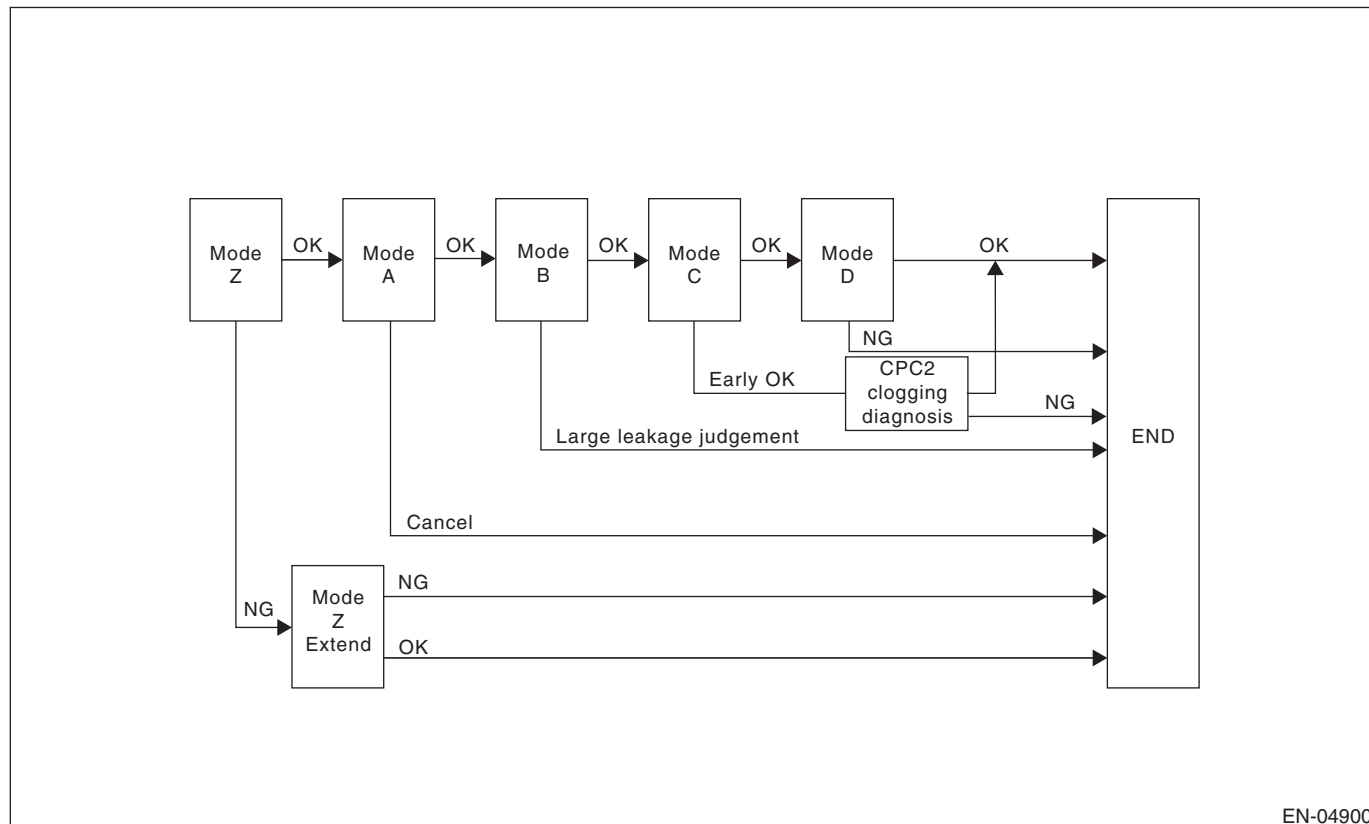

EN-04900

Mode	Mode Description	Diagnosis Period
Mode Z (Purge control solenoid valve opening failure diagnosis)	Perform purge control solenoid valve opening failure diagnosis from the size of tank pressure variation from diagnosis start.	3 — 16 seconds
Mode A (Estimated evaporation amount)	Calculate the tank pressure change amount (P1).	10 seconds
Mode B (Sealed negative pressure, large leakage judgement)	Decrease the pressure in the tank to the target value by introducing the intake manifold pressure to the fuel tank. If the tank pressure cannot be reduced, it is diagnosed as large leak.	5 — 25 seconds
Mode C (Pressure increase check, advanced OK judgment)	Wait until the tank pressure returns to the target (start level of P2 calculation). If the tank pressure does not become the value, make advanced OK judgment.	1 — 15 seconds
Mode D (Negative pressure variation measurement, evaporation leakage diagnosis)	Calculate the tank pressure variation (P2), and obtain the diagnostic value using P1 found in Mode A. Perform the evaporation diagnosis using the diagnostic value.	10 seconds
Blockage diagnosis of purge control solenoid 2	Depending on the amount of change in tank inner pressure during and after mode C end, perform blockage diagnosis of purge control solenoid 2.	3 seconds

# Diagnostic Trouble Code (DTC) Detecting Criteria

## GENERAL DESCRIPTION

### Mode Table for Evaporative Emission Control System Diagnosis

Mode	Tank internal pressure under normal conditions	Diagnostic item	DTC
Mode Z	Roughly the same as atmospheric pressure (Same as 0 kPa (0 mmHg, 0 inHg))	Purge control solenoid valve is judged to be open.	P0457
Mode A	Pressure is in proportion to amount of evaporative emission.		
Mode B	Negative pressure is formed due to intake manifold negative pressure.	Large leak	P0457
Mode C	Reaches target pressure		None
Mode D	Pressure change is small.	EVAP system large leak determination. [1.0 mm (0.04 in)]	P0442

### 0.02-inch Diagnosis

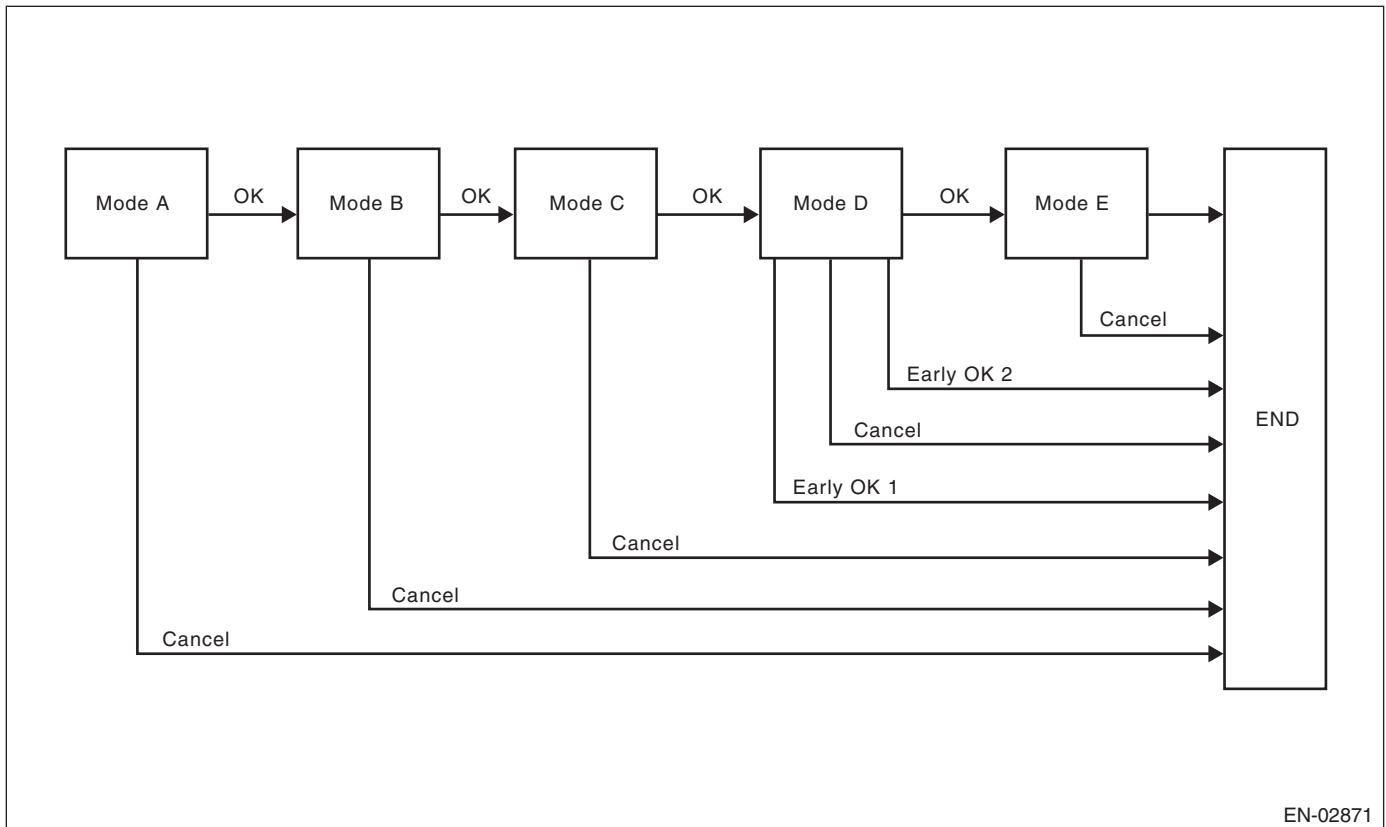

EN-02871

Mode	Mode Description	Diagnosis Period
Mode A (0 point compensation)	When the pressure in the tank is high, wait until it returns to 0 point (Near 0 mmHg).	0 — 12 seconds
Mode B (Negative pressure introduced)	Decrease the pressure in the tank to the target value by introducing the intake manifold pressure to the fuel tank.	0 — 27 seconds
Mode C (Negative pressure maintained)	Wait until the tank pressure returns to the target (start level of P2 calculation).	0 — 20 seconds
Mode D (Negative pressure change calculated)	Calculate the time it takes for the tank pressure to return to the P2 calculation complete pressure. If the tank pressure does not return to the P2 calculation complete pressure, make advanced OK judgment.	0 — 200 seconds
Mode E (Evaporation generated amount calculated)	Calculate the amount of evaporation (P1).	0 — 280 seconds

## 2. COMPONENT DESCRIPTION

### Pressure control solenoid valve

PCV controls the fuel tank pressure to be equal to the atmospheric air pressure. Normally, the solenoid is set to OFF. And the valve opens and closes mechanically in accordance with the pressure difference between tank and atmospheric air, or tank and canister.

The valve is forcibly opened by setting the solenoid to ON at the time of diagnosis.

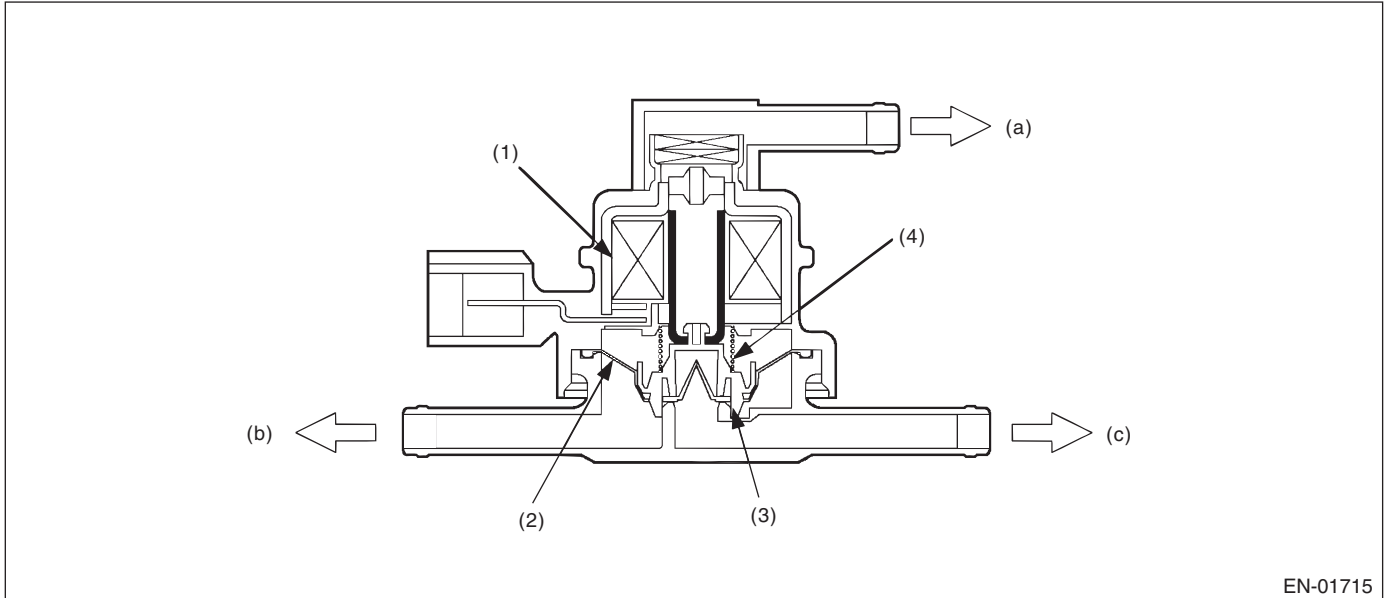

- (1) Solenoid
- (2) Diaphragm

- (3) Valve
- (4) Spring

- (a) Atmosphere pressure
- (b) Fuel tank
- (c) Canister

# Diagnostic Trouble Code (DTC) Detecting Criteria

## GENERAL DESCRIPTION

### Valve Operation and Air Flow

In the figure below, divided by the diaphragm, the part above X is charged with atmospheric air pressure, and the part below X is charged with tank pressure. Also, the part above Y is charged with tank pressure, and the part below Y is charged with canister pressure.

If the atmospheric air pressure port is A, tank pressure port is B, and canister pressure port is C, the air flows according to pressure difference from each port as shown in the table below.

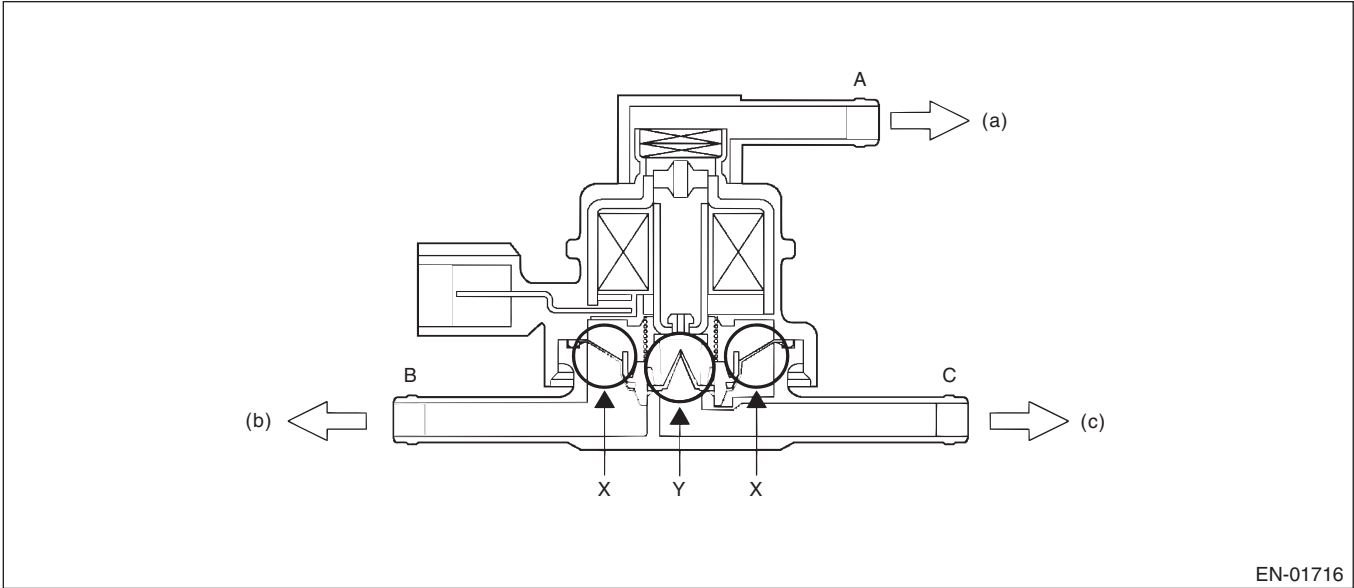

(a) Atmosphere pressure

(b) Fuel tank

(c) Canister

Condition of pressure	Flow
A < B (solenoid OFF)	B → C
B < C (solenoid OFF)	C → B
Solenoid ON	B ↔ C

### When A < B (Solenoid OFF)

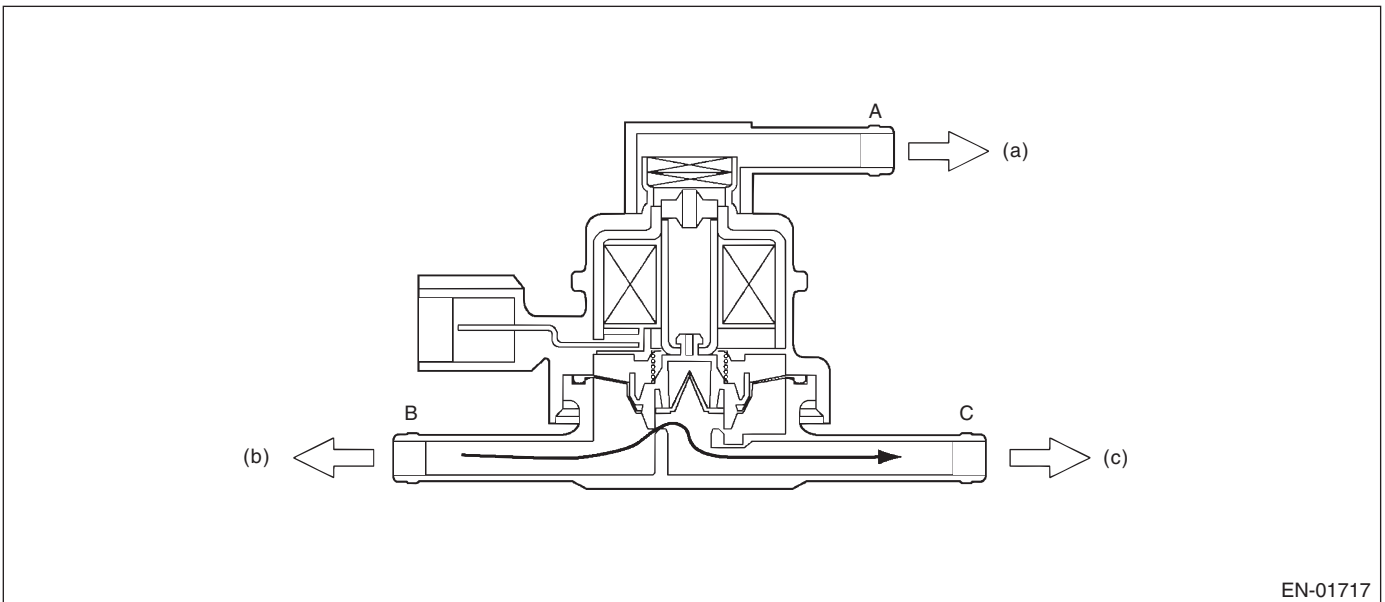

(a) Atmosphere pressure

(b) Fuel tank

(c) Canister



# Diagnostic Trouble Code (DTC) Detecting Criteria

GENERAL DESCRIPTION

## When $B < C$ (Solenoid OFF)

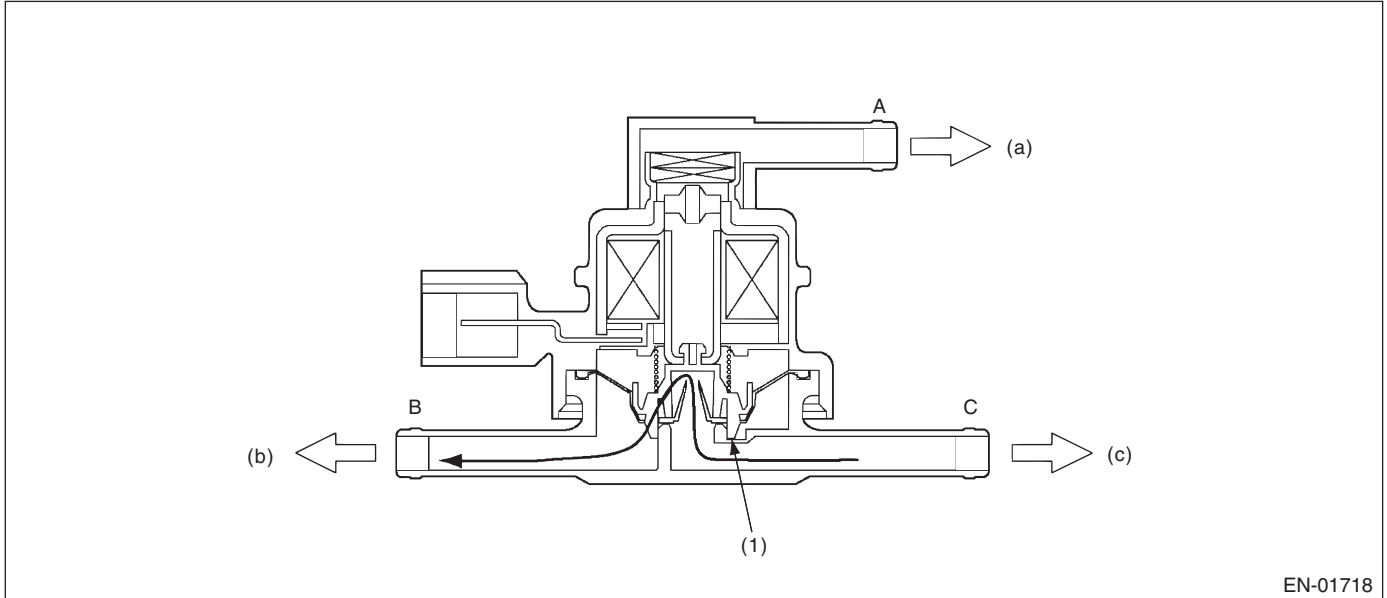

EN-01718

- (1) Valve
- (a) Atmosphere pressure
- (b) Fuel tank
- (c) Canister

## When Solenoid is ON

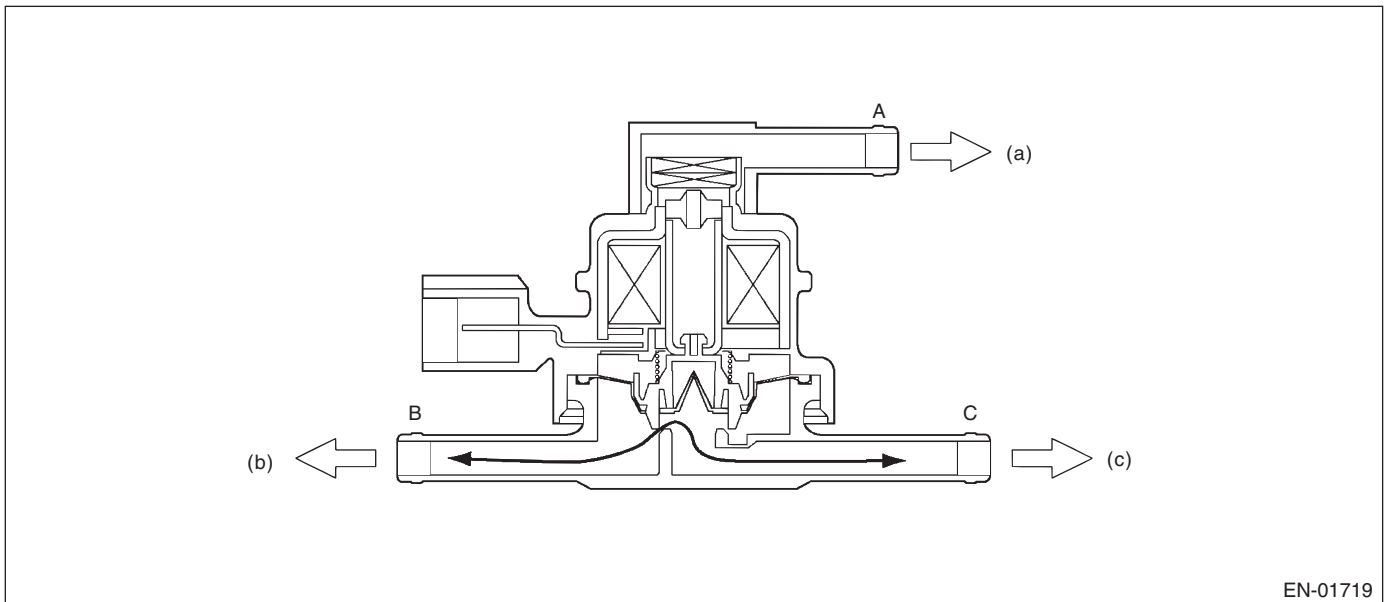

EN-01719

- (a) Atmosphere pressure
- (b) Fuel tank
- (c) Canister

# Diagnostic Trouble Code (DTC) Detecting Criteria

## GENERAL DESCRIPTION

### Drain valve

Drain valve controls the ambient air to be introduced to the canister.

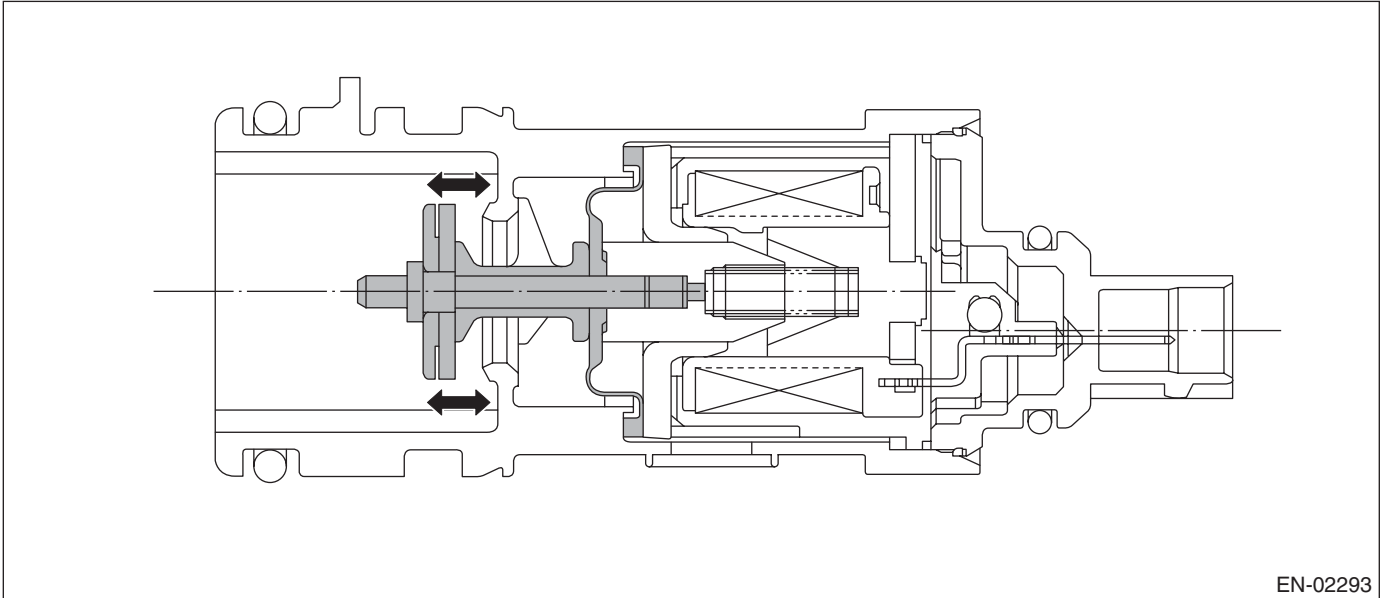

EN-02293

## 3. ENABLE CONDITION

### 0.04-inch Diagnosis

Secondary Parameters	Enable Conditions
Battery voltage	$\geq 10.9$ V
Barometric pressure	$\geq 75.0$ kPa (563 mmHg, 22.2 inHg)
Total time of canister purge operation	120 seconds or more
After engine starting	856 seconds or more
Learning value of evaporation gas density	$\leq 0.04$
Engine speed	1050 — 6500 rpm
Fuel tank pressure	$\geq -1.4$ kPa (-10.7 mmHg, -0.42 inHg)
Intake manifold vacuum (relative pressure)	$< -13.3$ kPa (-100 mmHg, -3.94 inHg)
Vehicle speed	$\geq 32$ km/h (19.9 MPH)
Fuel level	9 — 51 $\varnothing$ (2.38 — 13.47 US gal, 1.98 — 11.22 Imp gal)
Closed air/fuel ratio control	In operation
Fuel temperature	-10 — 45°C (14 — 113°F)
Intake air temperature	$\geq -10$ °C (14°F)
Pressure change per second	$< 0.23$ kPa (1.7 mmHg, 0.07 inHg)
Minimum pressure change value every one second — Maximum pressure change value every one second	$< 0.23$ kPa (1.7 mmHg, 0.07 inHg)
Change of fuel level	$< 2.5$ $\varnothing$ /128 milliseconds (0.66 US gal/128 milliseconds, 0.55 Imp gal/128 milliseconds)
Air fuel ratio	0.76 — 1.25

# Diagnostic Trouble Code (DTC) Detecting Criteria

GENERAL DESCRIPTION

## 0.02-inch Diagnosis

Secondary Parameters	Enable Condition
(At starting a diagnosis)	
Evap. diagnosis	Incomplete
Battery voltage	$\geq 10.9$ V
Atmosphere pressure	$\geq 75.0$ kPa (563 mmHg, 22.2 inHg)
Time since last incomplete diagnosis event of 0.02-inch leakage	
When cancelling in mode A	$> 120$ seconds
When cancelling in other than mode A	$> 600$ seconds
Total time of canister purge operation	120 seconds or more
After engine starting	770 seconds or more
Fuel temperature	$-10 - 70^{\circ}\text{C}$ ( $14 - 158^{\circ}\text{F}$ )
Fuel level	$9 - 51 \varnothing$ (2.38 — 13.47 US gal, 1.98 — 11.22 Imp gal)
Intake manifold vacuum (relative pressure)	$< -13.3$ kPa ( $-100$ mmHg, $-3.93$ inHg)
Fuel tank pressure	$-0.67 - 1.43$ kPa ( $-5 - 10.7$ mmHg, $-0.20 - 0.42$ inHg)
Vehicle speed	$\geq 68$ km/h (42 MPH)
Closed air/fuel ratio control	In operation
Engine speed	550 — 6000 rpm
(During diagnosis)	
Change of fuel level	$\leq$ Value from Map
Pressure change every one second	$< 0.06$ kPa (0.44 mmHg, 0.02 inHg)
Minimum pressure change value every one second – Maximum pressure change value every one second	$< 0.07$ kPa (0.51 mmHg, 0.02 inHg)
Pressure change in tank every second	$\leq 0.1$ kPa (0.75 mmHg, 0.03 inHg)
Atmospheric pressure change (Mode D)	$-0.47 - 0.32$ kPa ( $-3.5 - 2.4$ mmHg, $-0.14 - 0.09$ inHg)
Atmospheric pressure change (Mode E)	$-0.32 - 0.32$ kPa ( $-2.4 - 2.4$ mmHg, $-0.09 - 0.09$ inHg)

## Map

Fuel level ( $\varnothing$ , US gal, Imp gal)	0	10, 2.64, 2.2	20, 5.28, 4.4	30, 7.93, 6.6	40, 10.57, 8.8	50, 13.21, 11	60, 15.85, 13.2
Change ( $\varnothing$ , US gal, Imp gal)	4.2, 1.11, 0.92	4.2, 1.11, 0.92	4.1, 1.08, 0.9	4.0, 1.06, 0.88	3.9, 1.03, 0.86	3.8, 1.0, 0.84	3.8, 1.0, 0.84

## 4. GENERAL DRIVING CYCLE

### 0.04-inch Diagnosis

- Perform the diagnosis only once in 856 seconds or more after starting the engine, at a constant speed of 32 km/h (19.9 MPH) or more.
- Pay attention to the fuel temperature and fuel level.

### 0.02-inch Diagnosis

- Perform the diagnosis after 770 seconds or more after starting the engine, at a constant engine speed of 68 km/h (42 MPH) or higher, to judge as NG or OK.
- If judgment cannot be made, repeat the diagnosis.
- Be careful of the remaining fuel level.

# Diagnostic Trouble Code (DTC) Detecting Criteria

## GENERAL DESCRIPTION

### 5. DIAGNOSTIC METHOD

#### Purge control solenoid valve stuck open fault diagnosis

DTC

P0457 Evaporative Emission Control System Leak Detected (Fuel Cap Loose/Off)

#### Purpose of Mode Z

When performing the leakage diagnosis of EVAP system, the purge control solenoid valve must operate normally. Therefore, mode Z is used to diagnose the purge control solenoid valve stuck open condition. Note that if a purge control solenoid valve stuck open fault is detected, the EVAP system leakage diagnosis is cancelled.

Diagnostic Method

Purge control solenoid valve functional diagnosis is performed by monitoring the tank pressure in mode Z.

#### Normality Judgment

Judge OK and change to Mode A when the criteria below are completed in 3 seconds after Mode Z started.

#### Judgment Value

Malfunction Criteria	Threshold Value	DTC
(Tank pressure when Mode Z started) – (Tank pressure when Mode Z finished)	$\leq 0.4$ kPa (3 mmHg, 0.12 inHg)	P0457

#### Normal

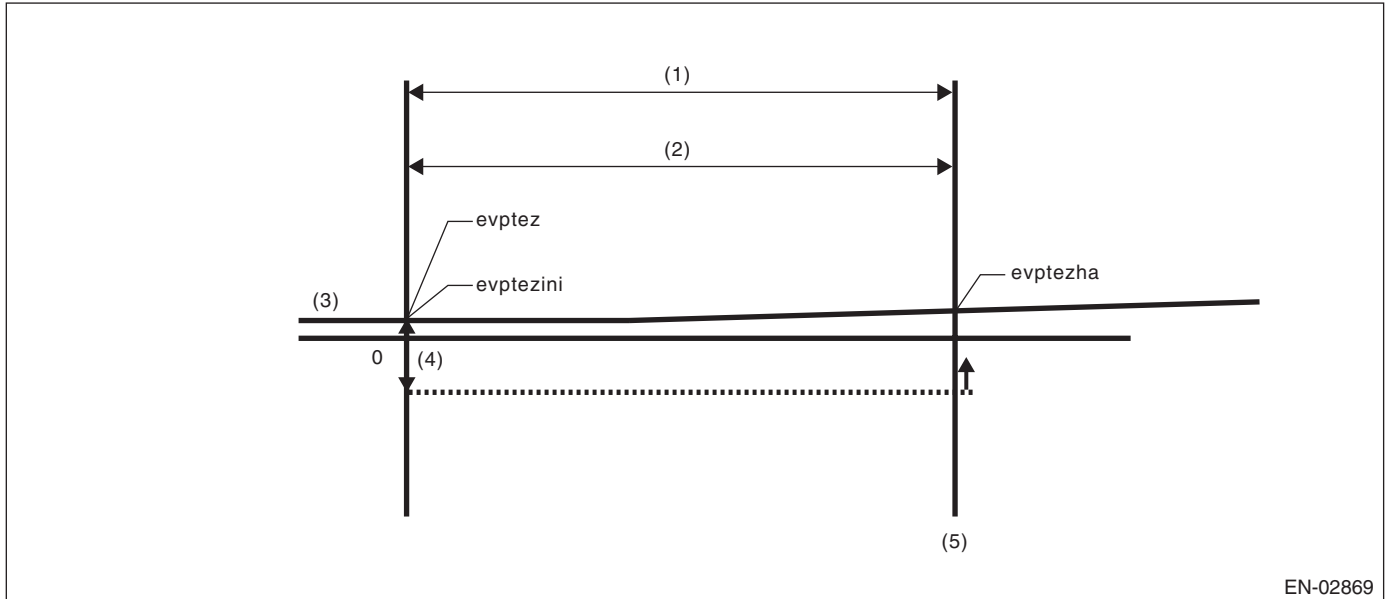

EN-02869

- |               |                                   |                 |
|---------------|-----------------------------------|-----------------|
| (1) Mode Z    | (3) Fuel tank pressure            | (5) OK judgment |
| (2) 3 seconds | (4) 0.4 kPa (3.0 mmHg, 0.12 inHg) |                 |

- $evptez - evptezha \leq 0.4$  kPa (3.0 mmHg, 0.12 inHg)
- $evptezini - evptezha \leq 0.4$  kPa (3.0 mmHg, 0.12 inHg)

Judge as normal when both calculations are established.

# Diagnostic Trouble Code (DTC) Detecting Criteria

GENERAL DESCRIPTION

## Abnormality Judgment

If OK judgment cannot be made, extend Mode Z 16 seconds more, and judge as NG when all the criteria below are completed after 16 seconds.

## Judgment Value

Malfunction Criteria	Threshold Value	DTC
(Tank pressure when Mode Z started) – (Tank pressure when Mode Z finished)	> 0.6 kPa (4.5 mmHg, 0.18 inHg)	P0457
Tank pressure when Mode Z started	≤ 1.43 kPa (10.7 mmHg, 0.42 inHg)	
2 ℓ or more fuel must remain in a static (not sloshing) condition for more than:	≥ 40 sec.	

**Time Needed for Diagnosis:** 16 seconds

**Malfunction Indicator Light Illumination:** Illuminates when malfunction occurs in 2 continuous driving cycles.

When judgment for purge control solenoid valve stuck open NG is made, end the evaporative diagnosis. Cancel the evaporative diagnosis when the OK/NG judgment for purge control solenoid valve stuck open cannot be made in Mode Z.

# Diagnostic Trouble Code (DTC) Detecting Criteria

## GENERAL DESCRIPTION

### Purge Control Solenoid Valve Open Fixation

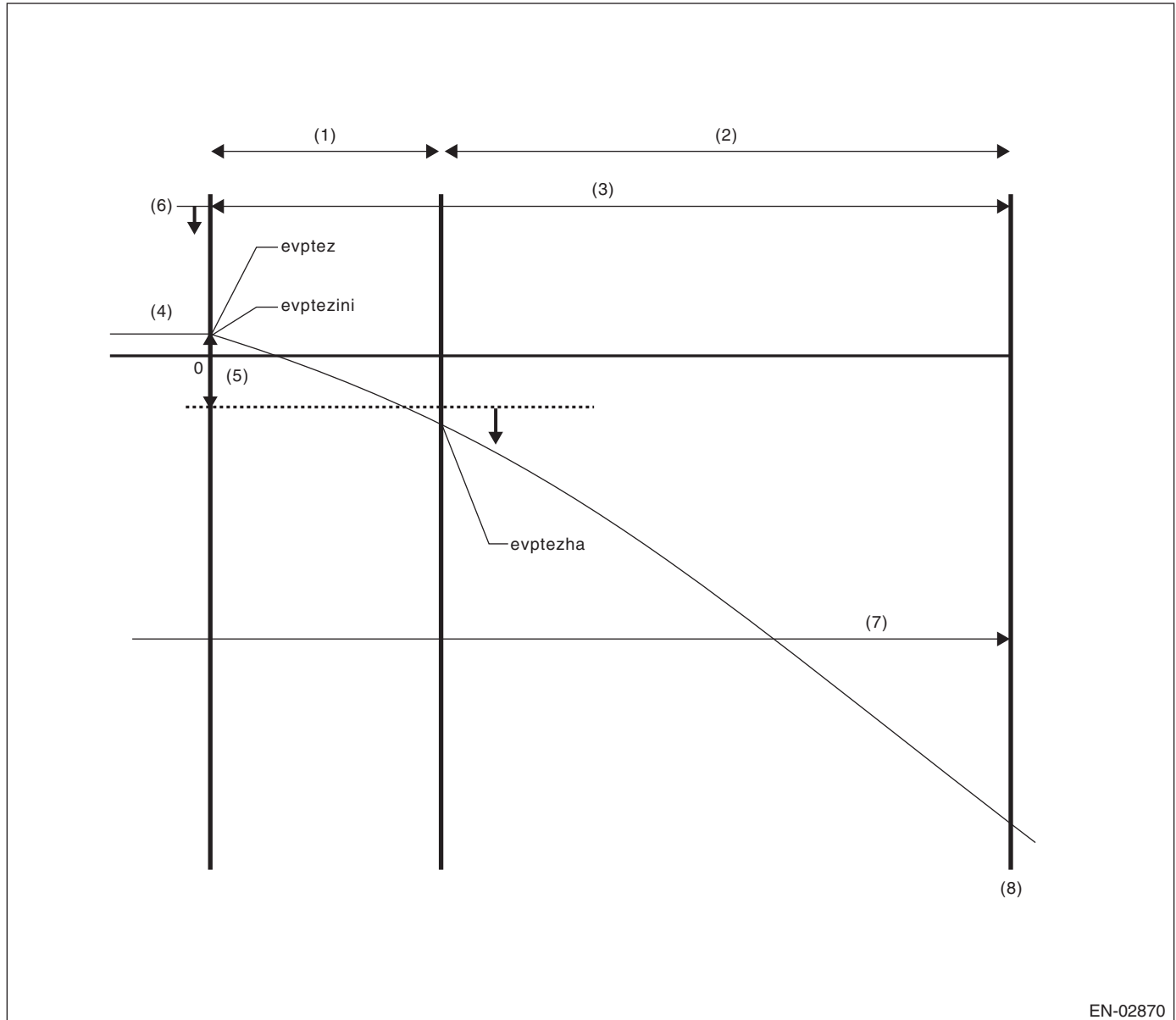

EN-02870

- |                     |                                     |                                     |
|---------------------|-------------------------------------|-------------------------------------|
| (1) Mode Z          | (4) Fuel tank pressure              | (7) No fuel sloshing for 40 seconds |
| (2) Extended mode Z | (5) 0.87 kPa (6.5 mmHg, 0.26 inHg)  | (8) NG judgment                     |
| (3) 16 seconds      | (6) 1.43 kPa (10.7 mmHg, 0.42 inHg) |                                     |

- $evptezini, evptez \leq 1.43 \text{ kPa (10.7 mmHg, 0.42 inHg)}$
  - $evptez - evptezha \leq 0.87 \text{ kPa (6.5 mmHg, 0.26 inHg)}$
  - $evptezini - evptezha \leq 0.87 \text{ kPa (6.5 mmHg, 0.26 inHg)}$
  - No fuel sloshing of over 2  $\varnothing$  (0.53 US gal, 0.44 Imp gal) for 40 seconds or more.
- Judge as normal when all are established.

### Leak Diagnosis

DTC

P0442 CPC Solenoid Function (Blocked)

P0442 Evaporative Emission Control System Leak Detected (Small Leak)

P0457 Evaporative Emission Control System Leak Detected (Fuel Cap Loose/Off)

# Diagnostic Trouble Code (DTC) Detecting Criteria

GENERAL DESCRIPTION

## Diagnostic method

- The diagnostic method consists of creating a sealed vacuum in the fuel tank and then determining the presence of leakage from the speed at which the tank internal pressure returns to atmospheric pressure.
- The diagnosis is divided into the following five phases.

### Mode A: (Estimated evaporation gas amount)

Calculate the tank pressure change amount (P1) when using mode A. After calculating P1, switch to mode B.

### Mode B: (Negative pressure sealed)

Introduce negative pressure in the intake manifold to the tank.

Approximately 0 → -1.4 kPa (0 → -10.5 mmHg, 0 → -0.41 inHg)

When the pressure above (desired negative pressure) is reached, enters Mode C.

In this case, if the tank pressure does not reach the target negative pressure, judge that there is a large leakage (10 seconds or 25 seconds) in the system and terminate the evaporative emission control system diagnosis.

### Abnormality Judgment

Judge as NG (large leak) when the criteria below are met.

### Judgment Value

Malfunction Criteria	Threshold Value	DTC
Time to reach target negative pressure Or mode B time (Min. pressure value in tank when in mode B) – (Tank pressure when mode B started)	≥ 25 sec. ≥ 10 sec. > -0.5 kPa (-4 mmHg, -0.16 inHg)	P0457

### Mode C: (Check pressure rise)

Stop the introduction of negative pressure. (Wait until the tank pressure returns to the start level of P2 calculation.)

Change to Mode D when the tank pressure returns to the start level of P2 calculation.

Judge immediate OK and perform the blockage diagnosis of purge control solenoid 2 when it does not return in spite of spending the specified time.

Tank pressure when starting calculation of P2	Time for advanced OK judgment
-1.3 kPa (-9.75 mmHg, -0.38 inHg)	15 seconds

### Mode D: (Measure amount of negative pressure change)

Monitor the tank pressure change amount when using mode D. In this case, the tank pressure increases (nears atmospheric pressure), because evaporation occurs. However, if any leakage exists, the pressure increases additionally in proportion to this leakage. The pressure variation of this tank is P2.

After calculating P2, perform a small leak diagnosis according to the items below.

### When Mode D is ended

Assign tank variations measured in Mode A and Mode D; P1 and P2, to the formula below, judge small leaks in the system. If the measured judgment value exceeds the threshold value, it is judged to be a malfunction.

### Purge control solenoid valve 2 blockage diagnosis

Perform the purge control solenoid valve 2 blockage diagnosis according to the gap value of tank pressure from the end of mode C to afterwards.

Malfunction Criteria	Threshold Value	DTC
Tank pressure change after mode C completion.	3 seconds < 0.115 kPa (0.86 mmHg, 0.034 inHg)	P0441

# Diagnostic Trouble Code (DTC) Detecting Criteria

## GENERAL DESCRIPTION

### Abnormality Judgment

Judge as NG when the criteria below are met and judge as OK and clear NG when not met.

### Judgment Value

Malfunction Criteria	Threshold Value	DTC
P2 – 1.5 × P1 P2: Tank pressure that changes every 16 seconds in mode D P1: Tank pressure that changes every 16 seconds in mode A	> Value from Map 7 * Threshold value: Map (Remaining Fuel vs Tank temperature)	P0442

\* 1.5: Evaporation amount compensation value when below negative pressure (Amount of evaporation occurrence increases as a vacuum condition increases.)

### Map 7 Malfunction criteria limit for evaporation diagnosis

Fuel temperature vs Fuel level	5°C (41°F)	15°C (59°F)	25°C (77°F)	35°C (95°F)	45°C (113°F)
0 ℓ (0 US gal, 0 Imp gal)	0.49 kPa (3.68 mmHg, 0.14 inHg)	0.49 kPa (3.68 mmHg, 0.14 inHg)	0.53 kPa (3.95 mmHg, 0.16 inHg)	0.54 kPa (4.07 mmHg, 0.16 inHg)	0.56 kPa (4.17 mmHg, 0.16 inHg)
10 ℓ (2.64 US gal, 2.2 Imp gal)	0.49 kPa (3.68 mmHg, 0.14 inHg)	0.49 kPa (3.68 mmHg, 0.14 inHg)	0.53 kPa (3.95 mmHg, 0.16 inHg)	0.54 kPa (4.07 mmHg, 0.16 inHg)	0.56 kPa (4.17 mmHg, 0.16 inHg)
20 ℓ (5.28 US gal, 4.4 Imp gal)	0.50 kPa (3.77 mmHg, 0.15 inHg)	0.51 kPa (3.79 mmHg, 0.15 inHg)	0.53 kPa (4.01 mmHg, 0.16 inHg)	0.56 kPa (4.17 mmHg, 0.16 inHg)	0.57 kPa (4.27 mmHg, 0.17 inHg)
30 ℓ (7.93 US gal, 6.6 Imp gal)	0.51 kPa (3.85 mmHg, 0.15 inHg)	0.52 kPa (3.9 mmHg, 0.15 inHg)	0.54 kPa (4.06 mmHg, 0.16 inHg)	0.57 kPa (4.27 mmHg, 0.17 inHg)	0.60 kPa (4.48 mmHg, 0.18 inHg)
40 ℓ (10.57 US gal, 8.8 Imp gal)	0.65 kPa (4.88 mmHg, 0.19 inHg)	0.65 kPa (4.9 mmHg, 0.19 inHg)	0.66 kPa (4.98 mmHg, 0.20 inHg)	0.71 kPa (5.32 mmHg, 0.21 inHg)	0.76 kPa (5.73 mmHg, 0.23 inHg)
50 ℓ (13.21 US gal, 11.0 Imp gal)	0.794 kPa (5.96 mmHg, 0.235 inHg)	0.794 kPa (5.96 mmHg, 0.235 inHg)	0.794 kPa (5.96 mmHg, 0.235 inHg)	0.85 kPa (6.38 mmHg, 0.25 inHg)	0.88 kPa (6.6 mmHg, 0.26 inHg)
60 ℓ (15.85 US gal, 13.2 Imp gal)	0.794 kPa (5.96 mmHg, 0.235 inHg)	0.794 kPa (5.96 mmHg, 0.235 inHg)	0.794 kPa (5.96 mmHg, 0.235 inHg)	0.85 kPa (6.38 mmHg, 0.25 inHg)	0.88 kPa (6.6 mmHg, 0.26 inHg)

**Time Needed for Diagnosis:** 30 — 100 seconds

**Malfunction Indicator Light Illumination:** Illuminates when malfunction occurs in 2 continuous driving cycles.



# Diagnostic Trouble Code (DTC) Detecting Criteria

GENERAL DESCRIPTION

## Leak Diagnosis

DTC

P0456 Evaporative Emission Control System Leak Detected (very small leak)

Diagnostic method

- The diagnostic method consists of creating a sealed vacuum in the fuel tank and then determining the presence of leakage from the speed at which the tank internal pressure returns to atmospheric pressure.
- The diagnosis is divided into the following five phases.

### Mode A: (0 point compensation)

When the pressure in the tank is high, wait until it returns to 0 point (Near 0 mmHg.). Shift to mode B when returned to the 0 point. Cancel the diagnosis when 0 point does not return in the specified time.

### Mode B: (Negative pressure introduced)

Introduce negative pressure in the intake manifold to the tank.

Approximately 0 → -2.0 kPa (0 → -15 mmHg, 0 → -0.59 inHg)

When the pressure above (desired negative pressure) is reached, enters Mode C.

When the tank internal pressure does not reach the target vacuum pressure, the diagnosis is cancelled.

### Mode C: (Negative pressure maintained)

Stop the introduction of negative pressure. (Wait until the tank pressure returns to the start level of P2 calculation.)

Change to Mode D either when the tank pressure returns to the start level of P2 calculation, or when the pre-determined amount of time has passed.

### Mode D: (Calculate the amount of negative pressure change)

Monitor the tank pressure in mode D, calculate (P2) the pressure change in the tank, and measure the time (evpdset) for the tank pressure to return when calculation of P2 is completed. Shift to Mode E when the tank pressure returns to the end level of P2 calculation. If it does not return to the P2 calculation end tank internal pressure after the predetermined amount of time has passed, make advanced OK judgment or cancel the diagnosis.

## Normality Judgment

Judge as OK when the criteria below are met.

## Judgment Value

Malfunction Criteria	Threshold Value
Advanced OK judgment 1	
Mode D time	≥ 30 sec.
Tank internal pressure	≤ -1.8 kPa (-13.4 mmHg, -0.53 inHg)
Advanced OK judgment 2	
Mode D time	≥ 200 sec.
P2	≤ 0.9 — 1.3 kPa (7 — 9.6 mmHg, 0.28 — 0.38 inHg)

### Mode E: (Evaporation occurrence amount calculation)

Calculate the change of tank pressure with the time evpdset to judge as NG/OK according to the value of P1. (ambiguous determination acceptable).

# Diagnostic Trouble Code (DTC) Detecting Criteria

## GENERAL DESCRIPTION

### Abnormality Judgment

Judge as NG when the malfunction criteria below are met.

### Judgment Value

Malfunction Criteria	Threshold Value
P1	< Value from Map 7 * Threshold value: Map (Remaining fuel vs evpdset)

### Map 7 Malfunction criteria limit for evaporation diagnosis

Time (evpdset) vs Fuel level	0 seconds	30 seconds	80 seconds	100 seconds	150 seconds	200 seconds
0 ℓ (0 US gal, 0 Imp gal)	0 kPa (0 mmHg, 0 inHg)	0.21 kPa (1.6 mmHg, 0.06 inHg)	0.29 kPa (2.2 mmHg, 0.09 inHg)	0.29 kPa (2.2 mmHg, 0.09 inHg)	0.29 kPa (2.2 mmHg, 0.09 inHg)	0.29 kPa (2.2 mmHg, 0.09 inHg)
10 ℓ (2.64 US gal, 2.2 Imp gal)	0 kPa (0 mmHg, 0 inHg)	0.21 kPa (1.6 mmHg, 0.06 inHg)	0.29 kPa (2.2 mmHg, 0.09 inHg)	0.29 kPa (2.2 mmHg, 0.09 inHg)	0.29 kPa (2.2 mmHg, 0.09 inHg)	0.29 kPa (2.2 mmHg, 0.09 inHg)
30 ℓ (7.93 US gal, 6.6 Imp gal)	0 kPa (0 mmHg, 0 inHg)	0.21 kPa (1.6 mmHg, 0.06 inHg)	0.29 kPa (2.2 mmHg, 0.09 inHg)	0.29 kPa (2.2 mmHg, 0.09 inHg)	0.29 kPa (2.2 mmHg, 0.09 inHg)	0 kPa (0 mmHg, 0 inHg)
50 ℓ (13.21 US gal, 11.0 Imp gal)	0 kPa (0 mmHg, 0 inHg)	0.24 kPa (1.8 mmHg, 0.07 inHg)	0.29 kPa (2.2 mmHg, 0.09 inHg)	0.29 kPa (2.2 mmHg, 0.09 inHg)	0 kPa (0 mmHg, 0 inHg)	0 kPa (0 mmHg, 0 inHg)
60 ℓ (15.85 US gal, 13.2 Imp gal)	0 kPa (0 mmHg, 0 inHg)	0.24 kPa (1.8 mmHg, 0.07 inHg)	0.29 kPa (2.2 mmHg, 0.09 inHg)	0.29 kPa (2.2 mmHg, 0.09 inHg)	0 kPa (0 mmHg, 0 inHg)	0 kPa (0 mmHg, 0 inHg)
70 ℓ (18.49 US gal, 15.4 Imp gal)	0 kPa (0 mmHg, 0 inHg)	0.24 kPa (1.8 mmHg, 0.07 inHg)	0.29 kPa (2.2 mmHg, 0.09 inHg)	0.29 kPa (2.2 mmHg, 0.09 inHg)	0 kPa (0 mmHg, 0 inHg)	0 kPa (0 mmHg, 0 inHg)
80 ℓ (21.14 US gal, 17.6 Imp gal)	0 kPa (0 mmHg, 0 inHg)	0.24 kPa (1.8 mmHg, 0.07 inHg)	0.29 kPa (2.2 mmHg, 0.09 inHg)	0.29 kPa (2.2 mmHg, 0.09 inHg)	0 kPa (0 mmHg, 0 inHg)	0 kPa (0 mmHg, 0 inHg)

### Normality Judgment

Judge as OK when the criteria below are met.

### Judgment Value

Malfunction Criteria	Threshold Value
P1	> Value from Map 8 * Threshold value: Map (Remaining fuel vs evpdset)

# Diagnostic Trouble Code (DTC) Detecting Criteria

GENERAL DESCRIPTION

## Map 8 Fault criteria limit for Evaporative emission control system diagnosis

Time (evpdset) vs Fuel level	0 seconds	30 seconds	80 seconds	100 seconds	150 seconds	200 seconds
0 ℓ (0 US gal, 0 Imp gal)	0.16 kPa (1.2 mmHg, 0.05 inHg)	0.37 kPa (2.8 mmHg, 0.11 inHg)	0.45 kPa (3.4 mmHg, 0.13 inHg)	0.45 kPa (3.4 mmHg, 0.13 inHg)	0.45 kPa (3.4 mmHg, 0.13 inHg)	0.45 kPa (3.4 mmHg, 0.13 inHg)
10 ℓ (2.64 US gal, 2.2 Imp gal)	0.16 kPa (1.2 mmHg, 0.05 inHg)	0.37 kPa (2.8 mmHg, 0.11 inHg)	0.45 kPa (3.4 mmHg, 0.13 inHg)	0.45 kPa (3.4 mmHg, 0.13 inHg)	0.45 kPa (3.4 mmHg, 0.13 inHg)	0.45 kPa (3.4 mmHg, 0.13 inHg)
30 ℓ (7.93 US gal, 6.6 Imp gal)	0.16 kPa (1.2 mmHg, 0.05 inHg)	0.37 kPa (2.8 mmHg, 0.11 inHg)	0.45 kPa (3.4 mmHg, 0.13 inHg)	0.45 kPa (3.4 mmHg, 0.13 inHg)	0.45 kPa (3.4 mmHg, 0.13 inHg)	0.45 kPa (3.4 mmHg, 0.13 inHg)
50 ℓ (13.21 US gal, 11.0 Imp gal)	0.16 kPa (1.2 mmHg, 0.05 inHg)	0.40 kPa (3.0 mmHg, 0.12 inHg)	0.45 kPa (3.4 mmHg, 0.13 inHg)	0.45 kPa (3.4 mmHg, 0.13 inHg)	0.45 kPa (3.4 mmHg, 0.13 inHg)	0.45 kPa (3.4 mmHg, 0.13 inHg)
60 ℓ (15.85 US gal, 13.2 Imp gal)	0.16 kPa (1.2 mmHg, 0.05 inHg)	0.40 kPa (3.0 mmHg, 0.12 inHg)	0.45 kPa (3.4 mmHg, 0.13 inHg)	0.45 kPa (3.4 mmHg, 0.13 inHg)	0.45 kPa (3.4 mmHg, 0.13 inHg)	0.45 kPa (3.4 mmHg, 0.13 inHg)
70 ℓ (18.49 US gal, 15.4 Imp gal)	0.16 kPa (1.2 mmHg, 0.05 inHg)	0.40 kPa (3.0 mmHg, 0.12 inHg)	0.45 kPa (3.4 mmHg, 0.13 inHg)	0.45 kPa (3.4 mmHg, 0.13 inHg)	0.45 kPa (3.4 mmHg, 0.13 inHg)	0.45 kPa (3.4 mmHg, 0.13 inHg)
80 ℓ (21.14 US gal, 17.6 Imp gal)	0.16 kPa (1.2 mmHg, 0.05 inHg)	0.40 kPa (3.0 mmHg, 0.12 inHg)	0.45 kPa (3.4 mmHg, 0.13 inHg)	0.45 kPa (3.4 mmHg, 0.13 inHg)	0.45 kPa (3.4 mmHg, 0.13 inHg)	0.45 kPa (3.4 mmHg, 0.13 inHg)

**Time Needed for Diagnosis:** 65 — 516 seconds

**Malfunction Indicator Light Illumination:** Illuminates when malfunction occurs in 2 continuous driving cycles.

### 6. DTC CLEAR CONDITION

- When the OK idling cycle is completed 40 times in a row
- When “Clear Memory” is performed

### 7. MALFUNCTION INDICATOR LIGHT CLEAR CONDITION

- When the OK driving cycle is completed 3 times in a row
- When “Clear Memory” is performed

### 8. FAIL SAFE

None

### 9. ECM OPERATION AT DTC SETTING

- Memorize the freeze frame data. (For test mode \$02)
- Memorize the diagnostic value and trouble standard value. (For test mode \$06)

# Diagnostic Trouble Code (DTC) Detecting Criteria

## GENERAL DESCRIPTION

### BM:DTC P0447 EVAPORATIVE EMISSION CONTROL SYSTEM VENT CONTROL CIRCUIT OPEN

#### 1. OUTLINE OF DIAGNOSIS

Detect open or short circuit of the drain valve.

Judge as NG when the ECM output level differs from the actual terminal level.

#### 2. COMPONENT DESCRIPTION

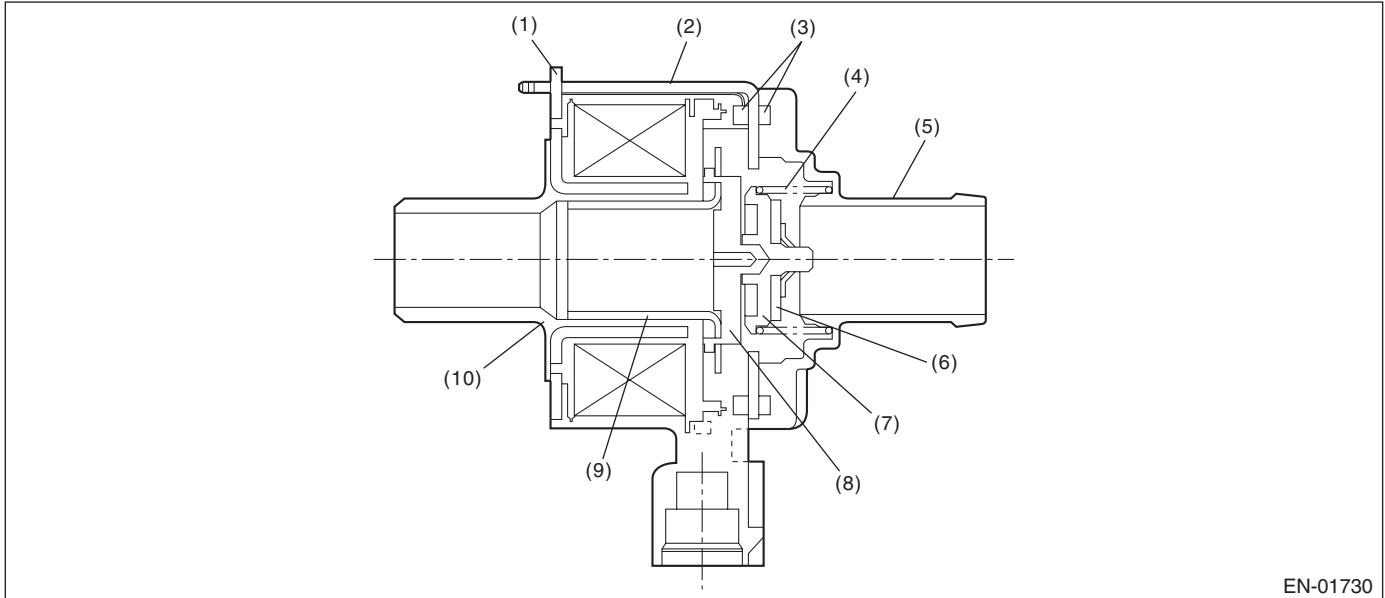

EN-01730

- (1) Magnetic plate
- (2) Yoke
- (3) Packing
- (4) Spring
- (5) Valve seat

- (6) Valve
- (7) Plate
- (8) Retainer
- (9) Movable core
- (10) Bobbin

#### 3. ENABLE CONDITION

Secondary Parameters	Enable Conditions
None	

#### 4. GENERAL DRIVING CYCLE

Always perform the diagnosis continuously.

# Diagnostic Trouble Code (DTC) Detecting Criteria

GENERAL DESCRIPTION

## 5. DIAGNOSTIC METHOD

### Abnormality Judgment

Judge as NG when the continuous time of meeting the malfunction criteria below becomes more than 2.5 seconds.

### Judgment Value

Malfunction Criteria	Threshold Value
Ignition switch	ON
Battery voltage	$\geq 10.9$ V
After engine starting	1 second or more
Terminal output voltage when ECM outputs OFF signal	Low

**Time Needed for Diagnosis:** 2.5 seconds

**Malfunction Indicator Light Illumination:** Illuminates as soon as a malfunction occurs.

### Normality Judgment

Judge as OK and clear the NG when all the malfunction criteria below are met.

### Judgment Value

Malfunction Criteria	Threshold Value
Ignition switch	ON
Battery voltage	$\geq 10.9$ V
After engine starting	1 second or more
Terminal output voltage when ECM outputs OFF signal	High

## 6. DTC CLEAR CONDITION

- When the OK idling cycle is completed 40 times in a row
- When "Clear Memory" is performed

## 7. MALFUNCTION INDICATOR LIGHT CLEAR CONDITION

- When the OK driving cycle is completed 3 times in a row
- When "Clear Memory" is performed

## 8. FAIL SAFE

Pressure control solenoid valve control: Open the pressure control solenoid valve.

## 9. ECM OPERATION AT DTC SETTING

Memorize the freeze frame data. (For test mode \$02)

# Diagnostic Trouble Code (DTC) Detecting Criteria

## GENERAL DESCRIPTION

### BN:DTC P0448 EVAPORATIVE EMISSION CONTROL SYSTEM VENT CONTROL CIRCUIT SHORTED

#### 1. OUTLINE OF DIAGNOSIS

Detect open or short circuit of the drain valve.

Judge as NG when the ECM output level differs from the actual terminal level.

#### 2. COMPONENT DESCRIPTION

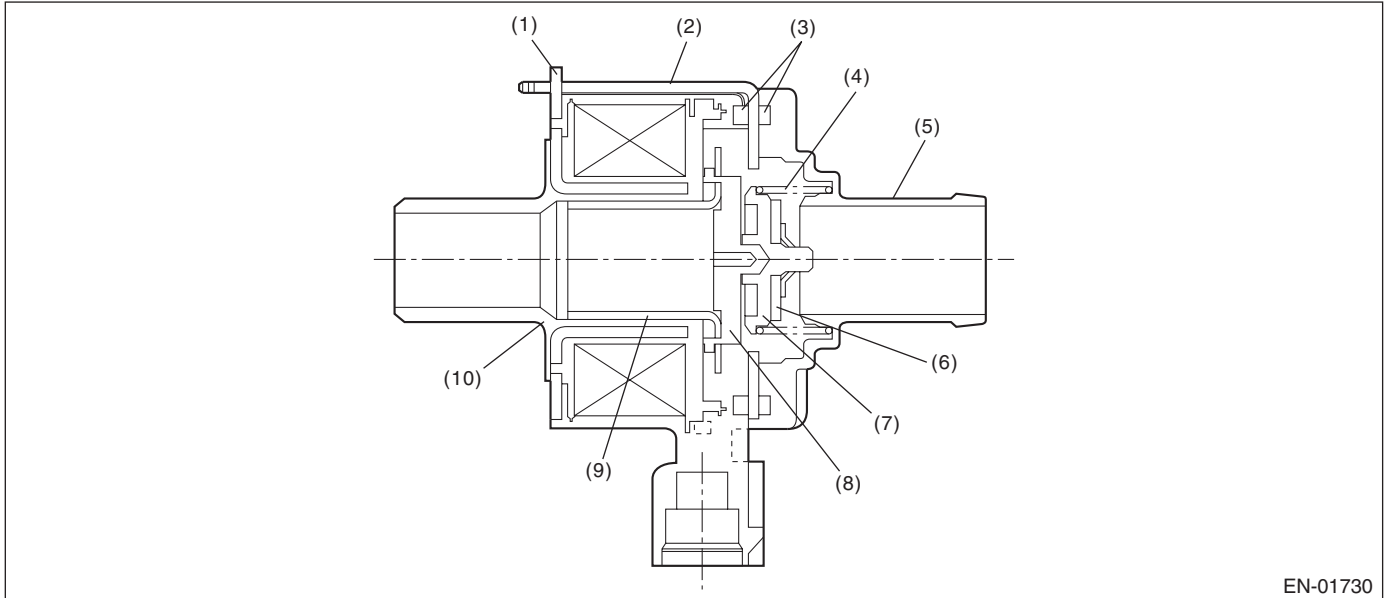

- (1) Magnetic plate
- (2) Yoke
- (3) Packing
- (4) Spring
- (5) Valve seat

- (6) Valve
- (7) Plate
- (8) Retainer
- (9) Movable core
- (10) Bobbin

#### 3. ENABLE CONDITION

Secondary Parameters	Enable Conditions
None	

#### 4. GENERAL DRIVING CYCLE

Always perform the diagnosis continuously.

# Diagnostic Trouble Code (DTC) Detecting Criteria

GENERAL DESCRIPTION

## 5. DIAGNOSTIC METHOD

### Abnormality Judgment

Judge as NG when the continuous time of meeting the malfunction criteria below becomes more than 2.5 seconds.

### Judgment Value

Malfunction Criteria	Threshold Value
Ignition switch	ON
Battery voltage	$\geq 10.9$ V
After engine starting	1 second or more
Terminal output voltage when ECM outputs ON signal	High

**Time Needed for Diagnosis:** 2.5 seconds

**Malfunction Indicator Light Illumination:** Illuminates as soon as a malfunction occurs.

### Normality Judgment

Judge as OK and clear the NG when all the malfunction criteria below are met.

### Judgment Value

Malfunction Criteria	Threshold Value
Ignition switch	ON
Battery voltage	$\geq 10.9$ V
After engine starting	1 second or more
Terminal output voltage when ECM outputs ON signal	Low

## 6. DTC CLEAR CONDITION

- When the OK idling cycle is completed 40 times in a row
- When "Clear Memory" is performed

## 7. MALFUNCTION INDICATOR LIGHT CLEAR CONDITION

- When the OK driving cycle is completed 3 times in a row
- When "Clear Memory" is performed

## 8. FAIL SAFE

Pressure control solenoid valve control: Open the pressure control solenoid valve.

## 9. ECM OPERATION AT DTC SETTING

Memorize the freeze frame data. (For test mode \$02)

# Diagnostic Trouble Code (DTC) Detecting Criteria

## GENERAL DESCRIPTION

### BO:DTC P0451 EVAPORATIVE EMISSION CONTROL SYSTEM PRESSURE SENSOR

#### 1. OUTLINE OF DIAGNOSIS

Detect the tank pressure sensor output property abnormality.

Judge NG when there is no pressure variation, which should exist in the tank, considering the engine status.

#### 2. COMPONENT DESCRIPTION

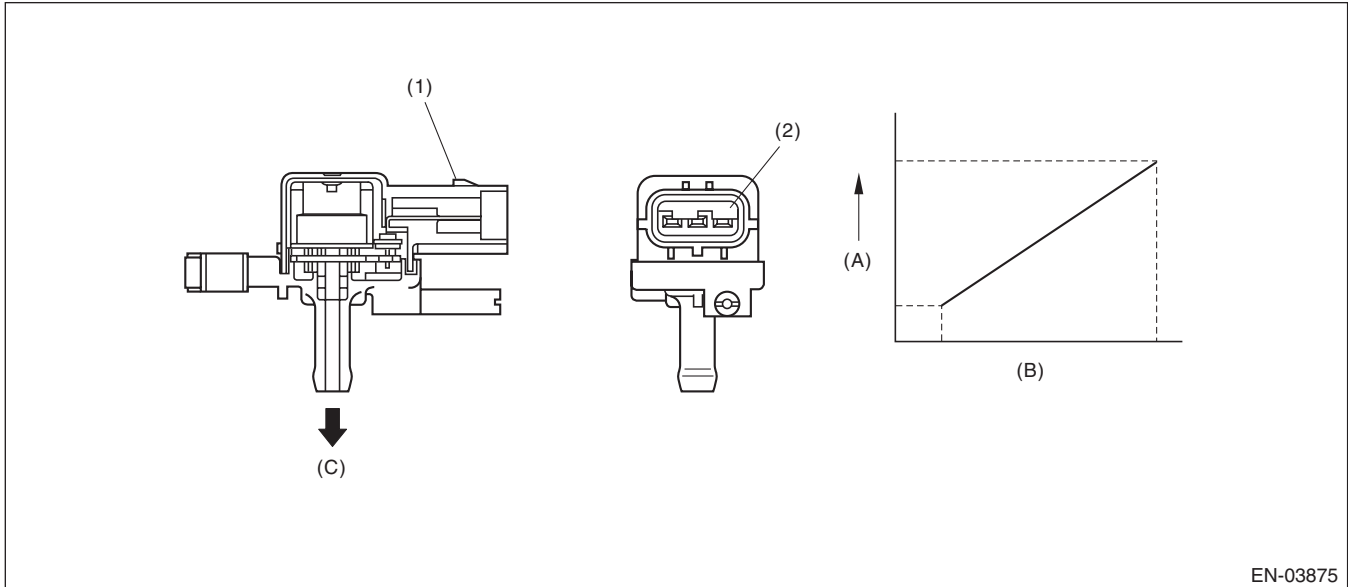

- (1) Connector
- (2) Terminal

- (A) Output voltage
- (B) Input voltage
- (C) To fuel tank

#### 3. ENABLE CONDITION

Secondary Parameters	Enable Conditions
After engine starting	60 seconds or more
Fuel level	$\geq 9 \text{ l}$ (2.38 US gal, 1.98 Imp gal)
Fuel temperature	$< 35^{\circ}\text{C}$ ( $95^{\circ}\text{F}$ )
Battery voltage	$\geq 10.9 \text{ V}$
Atmospheric pressure	$> 75.0 \text{ kPa}$ (563 mmHg, 22.2 inHg)
Purge control solenoid valve ON/OFF	Experienced

#### 4. GENERAL DRIVING CYCLE

- Perform the diagnosis continuously after 60 seconds or more have passed since the engine started.
- Be sure to check the fuel level and fuel temperature.



# Diagnostic Trouble Code (DTC) Detecting Criteria

GENERAL DESCRIPTION

## 5. DIAGNOSTIC METHOD

### Abnormality Judgment

Judge as NG when the malfunction criteria below are met.

### Judgment Value

Malfunction Criteria	Threshold Value
Number of times that the difference between the Max. fuel level and Min. fuel level every 60 seconds is 2 ℓ (0.53 US gal, 0.44 Imp gal) or more (with enable condition completed)	≥ 16 times
Maximum – Minimum tank pressure (with enable condition completed)	< 0.05 kPa (0.375 mmHg, 0.01 inHg)
Maximum – Minimum fuel temperature (with enable condition completed)	≥ 7°C (12.6°F)

If the maximum value – minimum value for the fuel level is less than 2 ℓ every 60 seconds, extend 60 seconds more and make judgment with the maximum and minimum values for the fuel level in 120 seconds. If a difference does not appear though the time was extended 60 seconds, extend the time (180, 240, 300 seconds) and continue the judgment. If the maximum value – minimum value for the fuel level is 5 liters or more, the diagnosis counter counts up.

**Time Needed for Diagnosis:** 1 minute × 16 times or more

**Malfunction Indicator Light Illumination:** Illuminates when malfunction occurs in 2 continuous driving cycles.

### Normality Judgment

Judge as OK and clear the NG when the malfunction criteria below are met.

### Judgment Value

Malfunction Criteria	Threshold Value
Maximum – Minimum tank pressure	≥ 0.05 kPa (0.375 mmHg, 0.01 inHg)

## 6. DTC CLEAR CONDITION

- When the OK idling cycle is completed 40 times in a row
- When “Clear Memory” is performed

## 7. MALFUNCTION INDICATOR LIGHT CLEAR CONDITION

- When the OK driving cycle is completed 3 times in a row
- When “Clear Memory” is performed

## 8. FAIL SAFE

Purge control solenoid valve control: Not allowed to purge fixed mode.

## 9. ECM OPERATION AT DTC SETTING

Memorize the freeze frame data. (For test mode \$02)

# Diagnostic Trouble Code (DTC) Detecting Criteria

## GENERAL DESCRIPTION

### BP:DTC P0452 EVAPORATIVE EMISSION CONTROL SYSTEM PRESSURE SENSOR LOW INPUT

#### 1. OUTLINE OF DIAGNOSIS

Detect the open or short circuit of the fuel tank pressure sensor.  
Judge as NG if it is out of specification.

#### 2. COMPONENT DESCRIPTION

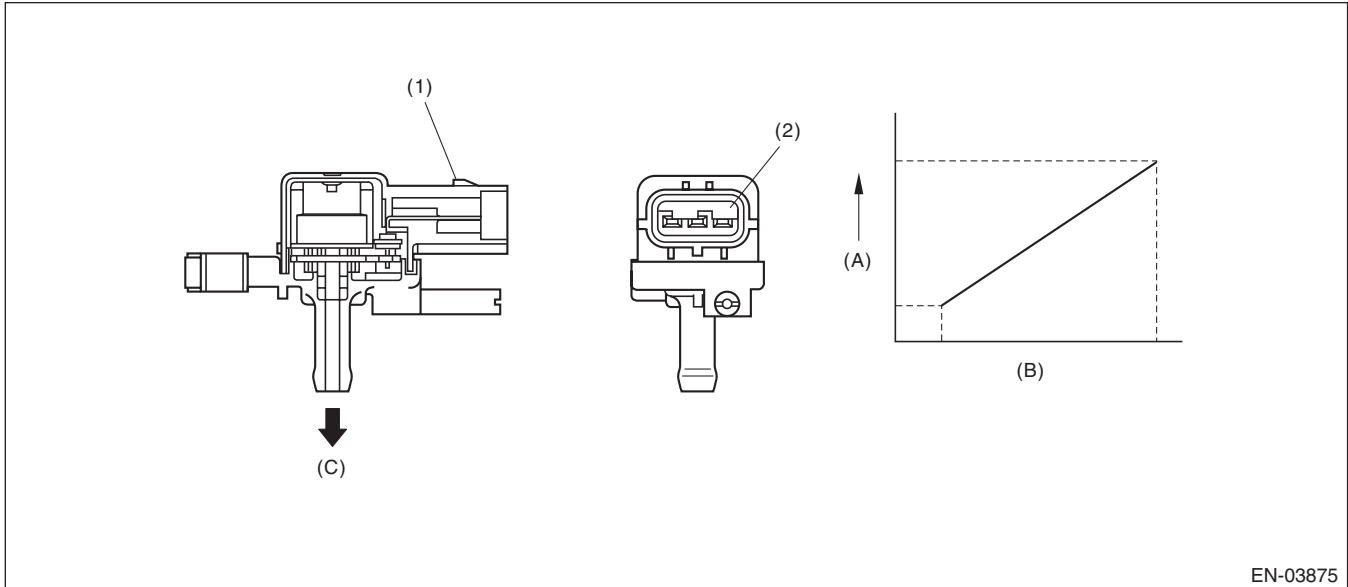

- (1) Connector
- (2) Terminal

- (A) Output voltage
- (B) Input voltage
- (C) To fuel tank

#### 3. ENABLE CONDITION (USED WITH HIGH SIDE NORMAL/ABNORMALITY JUDGMENT ONLY)

Secondary Parameters	Enable Condition
Battery voltage	$\geq 10.9 \text{ V}$

#### 4. GENERAL DRIVING CYCLE

Always perform the diagnosis continuously.

# Diagnostic Trouble Code (DTC) Detecting Criteria

GENERAL DESCRIPTION

## 5. DIAGNOSTIC METHOD

### Abnormality Judgment

Judge as NG when the continuous time of meeting the malfunction criteria below becomes 15 seconds or more.

### Judgment Value

Malfunction Criteria	Threshold Value
Fuel tank pressure	< -6.82 kPa (-56.15 mmHg, -2.01 inHg)

**Time Needed for Diagnosis:** 15 seconds

**Malfunction Indicator Light Illumination:** Illuminates as soon as a malfunction occurs.

### Normality Judgment

Judge as OK when the criteria below are met.

### Judgment Value

Malfunction Criteria	Threshold Value
Fuel tank pressure	≥ -6.82 kPa (-56.15 mmHg, -2.01 inHg)
Feedback lambda coefficient	≥ 0.9

## 6. DTC CLEAR CONDITION

- When the OK idling cycle is completed 40 times in a row
- When "Clear Memory" is performed

## 7. MALFUNCTION INDICATOR LIGHT CLEAR CONDITION

- When the OK driving cycle is completed 3 times in a row
- When "Clear Memory" is performed

## 8. FAIL SAFE

Purge control solenoid valve control: Not allowed to purge fixed mode.

## 9. ECM OPERATION AT DTC SETTING

Memorize the freeze frame data. (For test mode \$02)

# Diagnostic Trouble Code (DTC) Detecting Criteria

## GENERAL DESCRIPTION

### BQ:DTC P0453 EVAPORATIVE EMISSION CONTROL SYSTEM PRESSURE SENSOR HIGH INPUT

#### 1. OUTLINE OF DIAGNOSIS

Detect the open or short circuit of the fuel tank pressure sensor.  
Judge as NG if it is out of specification.

#### 2. COMPONENT DESCRIPTION

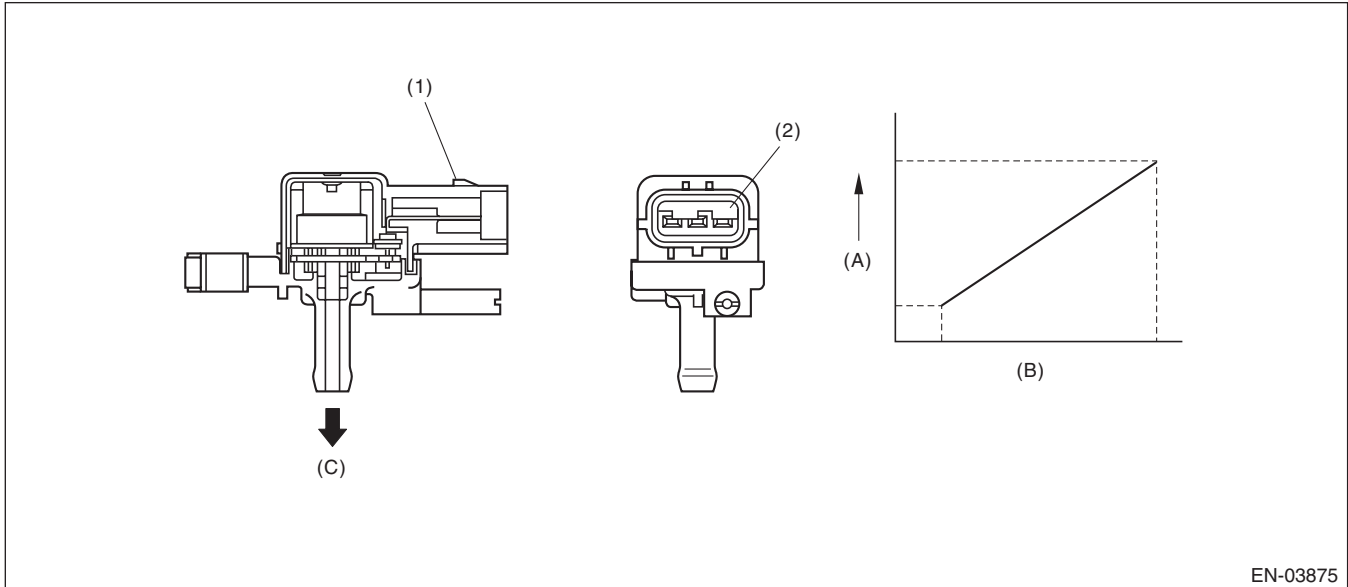

- (1) Connector
- (2) Terminal

- (A) Output voltage
- (B) Input voltage
- (C) To fuel tank

#### 3. ENABLE CONDITION

Secondary Parameters	Enable Conditions
Vehicle speed	$\geq 2$ km/h (1.24 MPH)
All conditions of EVAP canister purge	Complete
Learning value of evaporation gas density	$\leq 0.08$
Main feedback compensation coefficient	$\geq 0.9$
Battery voltage	$\geq 10.9$ V

#### 4. GENERAL DRIVING CYCLE

Perform the diagnosis continually when purging.

# Diagnostic Trouble Code (DTC) Detecting Criteria

GENERAL DESCRIPTION

## 5. DIAGNOSTIC METHOD

### Abnormality Judgment

Judge as NG when the continuous time of meeting the malfunction criteria below becomes 15 seconds or more.

### Judgment Value

Malfunction Criteria	Threshold Value
Fuel tank pressure	≥ 7.98 kPa (59.85 mmHg, 2.36 inHg)
Fuel temperature	< 35°C (95°F)
Atmospheric pressure	≥ 75.0 kPa (563 mmHg, 22.2 inHg)

**Time Needed for Diagnosis:** 15 seconds

**Malfunction Indicator Light Illumination:** Illuminates as soon as a malfunction occurs.

### Normality Judgment

Judge as OK when the criteria below are met.

### Judgment Value

Malfunction Criteria	Threshold Value
Fuel tank pressure	< 7.98 kPa (59.85 mmHg, 2.36 inHg)

## 6. DTC CLEAR CONDITION

- When the OK idling cycle is completed 40 times in a row
- When "Clear Memory" is performed

## 7. MALFUNCTION INDICATOR LIGHT CLEAR CONDITION

- When the OK driving cycle is completed 3 times in a row
- When "Clear Memory" is performed

## 8. FAIL SAFE

Purge control solenoid valve control: Not allowed to purge fixed mode.

## 9. ECM OPERATION AT DTC SETTING

Memorize the freeze frame data. (For test mode \$02)

### **BR:DTC P0456 EVAPORATIVE EMISSION CONTROL SYSTEM LEAK DETECTED (VERY SMALL LEAK)**

NOTE:

For the detection conditions, refer to DTC P0442 "EVAPORATIVE EMISSION CONTROL SYSTEM LEAK DETECTED (SMALL LEAK)". <Ref. to GD(H4DOTC)-132, DTC P0442 EVAPORATIVE EMISSION CONTROL SYSTEM LEAK DETECTED (SMALL LEAK), Diagnostic Trouble Code (DTC) Detecting Criteria.>

### **BS:DTC P0457 EVAPORATIVE EMISSION CONTROL SYSTEM LEAK DETECTED (FUEL CAP LOOSE/OFF)**

NOTE:

For the detection conditions, refer to DTC P0442 "EVAPORATIVE EMISSION CONTROL SYSTEM LEAK DETECTED (SMALL LEAK)". <Ref. to GD(H4DOTC)-132, DTC P0442 EVAPORATIVE EMISSION CONTROL SYSTEM LEAK DETECTED (SMALL LEAK), Diagnostic Trouble Code (DTC) Detecting Criteria.>

# Diagnostic Trouble Code (DTC) Detecting Criteria

## GENERAL DESCRIPTION

### BT:DTC P0458 EVAPORATIVE EMISSION SYSTEM PURGE CONTROL VALVE CIRCUIT LOW

#### 1. OUTLINE OF DIAGNOSIS

Detect open or short circuit of the purge control solenoid valve.

Judge as NG when the ECM output level differs from the actual terminal level.

#### 2. COMPONENT DESCRIPTION

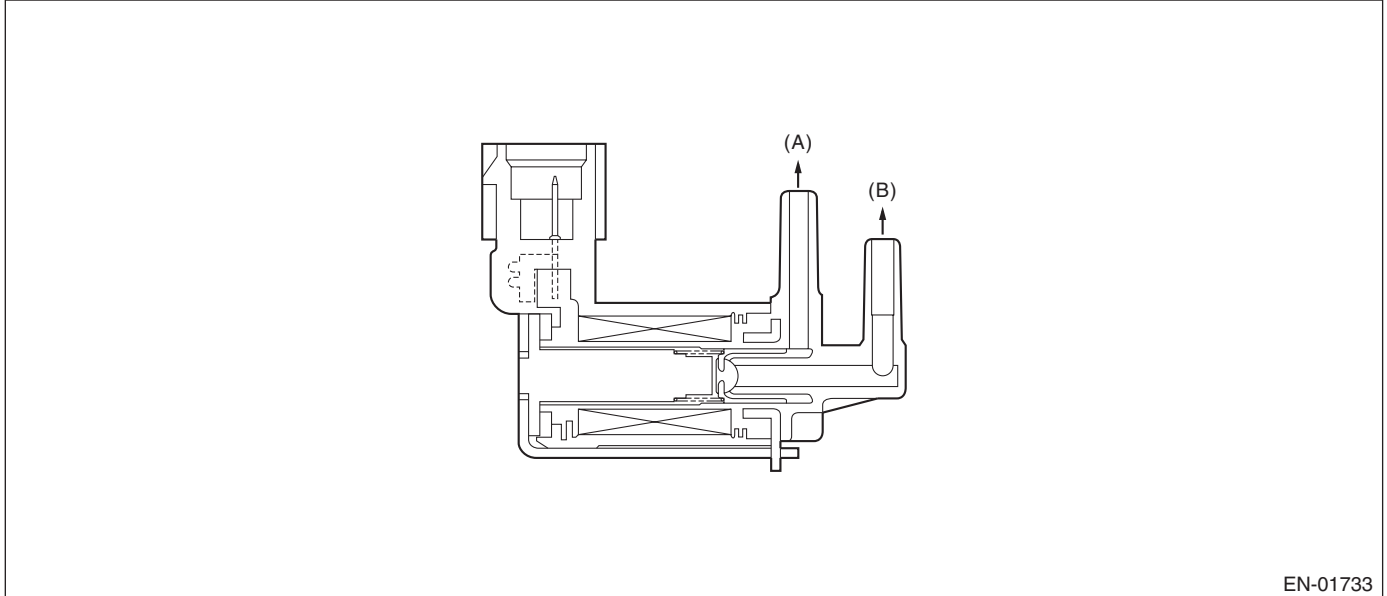

(A) To canister

(B) To intake manifold

#### 3. ENABLE CONDITION

Secondary Parameters	Enable Conditions
Ignition switch	ON
Battery voltage	$\geq 10.9 \text{ V}$
After engine starting	1 second or more

#### 4. GENERAL DRIVING CYCLE

Always perform the diagnosis after starting the engine.

# Diagnostic Trouble Code (DTC) Detecting Criteria

GENERAL DESCRIPTION

## 5. DIAGNOSTIC METHOD

### Abnormality Judgment

Judge as NG when the malfunction criteria below are met.

### Judgment Value

Malfunction Criteria	Threshold Value
Continuous time with the following conditions established:	$\geq 2.5$ sec.
Duty ratio of "ON"	$< 75\%$
Terminal output voltage	Low

**Time Needed for Diagnosis:** 2.5 seconds

**Malfunction Indicator Light Illumination:** Illuminates when malfunction occurs in 2 continuous driving cycles.

### Normality Judgment

Judge as OK and clear the NG when the malfunction criteria below are met.

### Judgment Value

Malfunction Criteria	Threshold Value
Terminal output voltage	High

## 6. DTC CLEAR CONDITION

- When the OK idling cycle is completed 40 times in a row
- When "Clear Memory" is performed

## 7. MALFUNCTION INDICATOR LIGHT CLEAR CONDITION

- When the OK driving cycle is completed 3 times in a row
- When "Clear Memory" is performed

## 8. FAIL SAFE

None

## 9. ECM OPERATION AT DTC SETTING

Memorize the freeze frame data. (For test mode \$02)

# Diagnostic Trouble Code (DTC) Detecting Criteria

## GENERAL DESCRIPTION

### BU:DTC P0459 EVAPORATIVE EMISSION SYSTEM PURGE CONTROL VALVE CIRCUIT HIGH

#### 1. OUTLINE OF DIAGNOSIS

Detect open or short circuit of the purge control solenoid valve.

Judge as NG when the ECM output level differs from the actual terminal level.

#### 2. COMPONENT DESCRIPTION

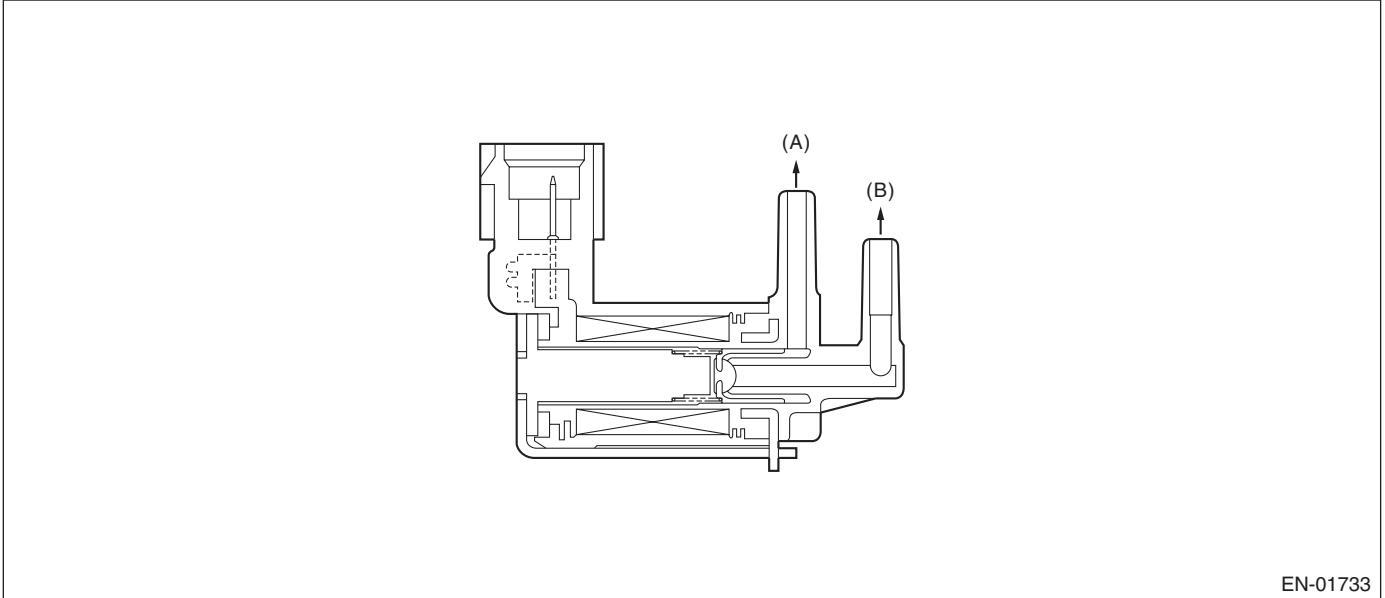

(A) To canister

(B) To intake manifold

#### 3. ENABLE CONDITION

Secondary Parameters	Enable Conditions
Ignition switch	ON
Battery voltage	$\geq 10.9 \text{ V}$
After engine starting	1 second or more

#### 4. GENERAL DRIVING CYCLE

Always perform the diagnosis after starting the engine.



# Diagnostic Trouble Code (DTC) Detecting Criteria

GENERAL DESCRIPTION

## 5. DIAGNOSTIC METHOD

### Abnormality Judgment

Judge as NG when the malfunction criteria below are met.

### Judgment Value

Malfunction Criteria	Threshold Value
Continuous time with the following conditions established:	≥ 2.5 sec.
Duty ratio of "ON"	≥ 25%
Terminal output voltage	High

**Time Needed for Diagnosis:** 2.5 seconds

**Malfunction Indicator Light Illumination:** Illuminates when malfunction occurs in 2 continuous driving cycles.

### Normality Judgment

Judge as OK and clear the NG when the malfunction criteria below are met.

### Judgment Value

Malfunction Criteria	Threshold Value
Terminal output voltage	Low

## 6. DTC CLEAR CONDITION

- When the OK idling cycle is completed 40 times in a row
- When "Clear Memory" is performed

## 7. MALFUNCTION INDICATOR LIGHT CLEAR CONDITION

- When the OK driving cycle is completed 3 times in a row
- When "Clear Memory" is performed

## 8. FAIL SAFE

None

## 9. ECM OPERATION AT DTC SETTING

Memorize the freeze frame data. (For test mode \$02)

# Diagnostic Trouble Code (DTC) Detecting Criteria

## GENERAL DESCRIPTION

### BV:DTC P0461 FUEL LEVEL SENSOR "A" CIRCUIT RANGE/PERFORMANCE

#### 1. OUTLINE OF DIAGNOSIS

Detect malfunctions of the fuel level sensor output property.

If the fuel level does not vary in a particular driving condition / engine condition where it should, judge as NG.

#### 2. COMPONENT DESCRIPTION

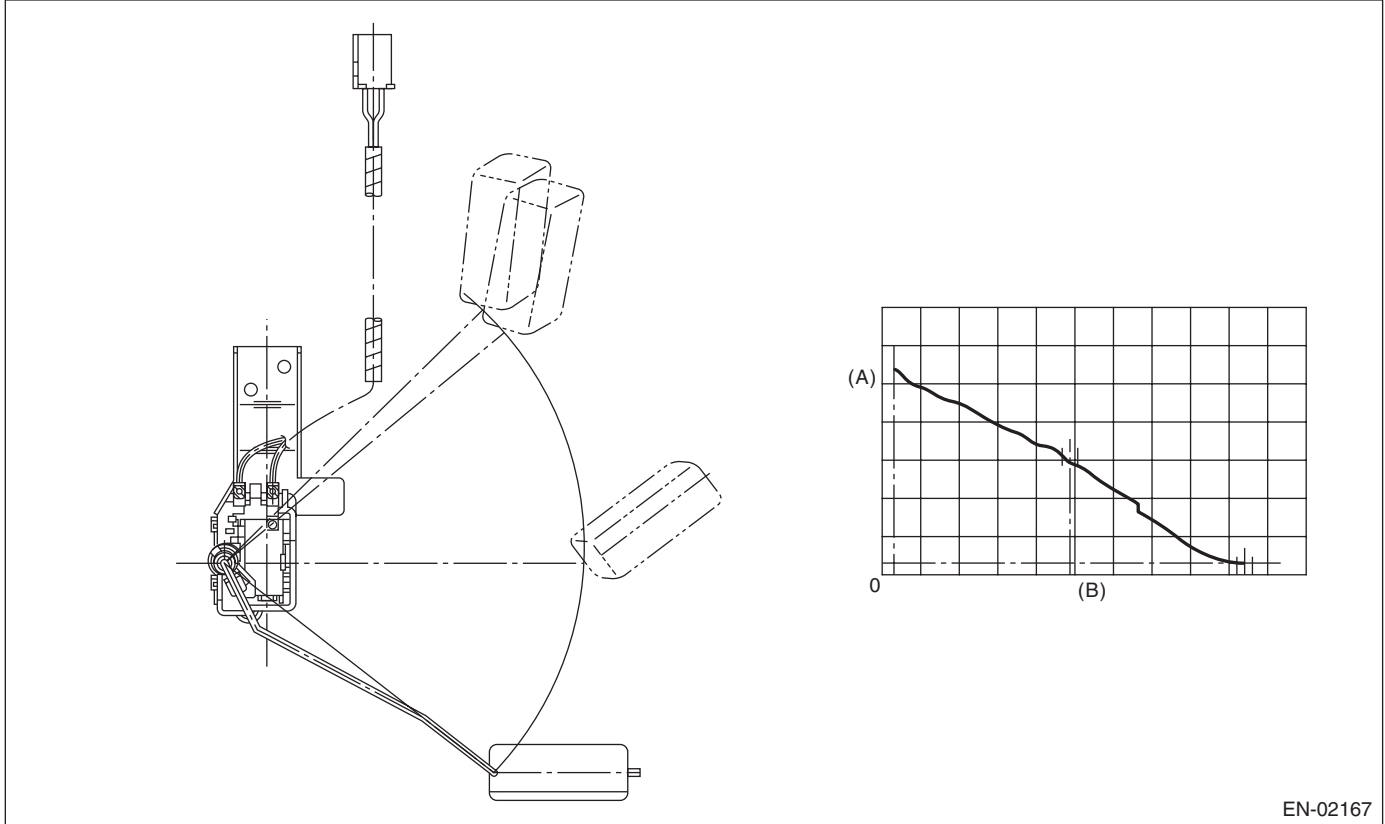

(A) Fuel level (L)

(B) Resistance ( $\Omega$ )

#### 3. ENABLE CONDITION

Secondary Parameters	Enable Conditions
None	

#### 4. GENERAL DRIVING CYCLE

Always perform the diagnosis continuously.

# Diagnostic Trouble Code (DTC) Detecting Criteria

GENERAL DESCRIPTION

## 5. DIAGNOSTIC METHOD

### Abnormality Judgment

Judge as NG when the malfunction criteria below are met.

### Judgment Value

Malfunction Criteria	Threshold Value
Accumulated amount of intake air	> 331 kg (729.8 lb)
Max. – Min. values of fuel level output	< 2.6 ℓ (0.69 US gal, 0.57 Imp gal)
Battery voltage	≥ 10.9 V
After engine starting	10 seconds or more

**Time Needed for Diagnosis:** Undetermined

**Malfunction Indicator Light Illumination:** Illuminates when malfunction occurs in 2 continuous driving cycles.

### Normality Judgment

Judge as OK and clear the NG when the malfunction criteria below are met.

### Judgment Value

Malfunction Criteria	Threshold Value
Accumulated amount of intake air	> 331 kg (729.8 lb)
Max. – Min. values of fuel level output	≥ 2.6 ℓ (0.69 US gal, 0.57 Imp gal)
Battery voltage	≥ 10.9 V
After engine starting	10 seconds or more

## 6. DTC CLEAR CONDITION

- When the OK idling cycle is completed 40 times in a row
- When “Clear Memory” is performed

## 7. MALFUNCTION INDICATOR LIGHT CLEAR CONDITION

- When the OK driving cycle is completed 3 times in a row
- When “Clear Memory” is performed

## 8. FAIL SAFE

None

## 9. ECM OPERATION AT DTC SETTING

Memorize the freeze frame data. (For test mode \$02)

# Diagnostic Trouble Code (DTC) Detecting Criteria

## GENERAL DESCRIPTION

### BW:DTC P0462 FUEL LEVEL SENSOR "A" CIRCUIT LOW

#### 1. OUTLINE OF DIAGNOSIS

Detect the open or short circuit of fuel level sensor. Judge as NG if it is out of specification.

#### 2. COMPONENT DESCRIPTION

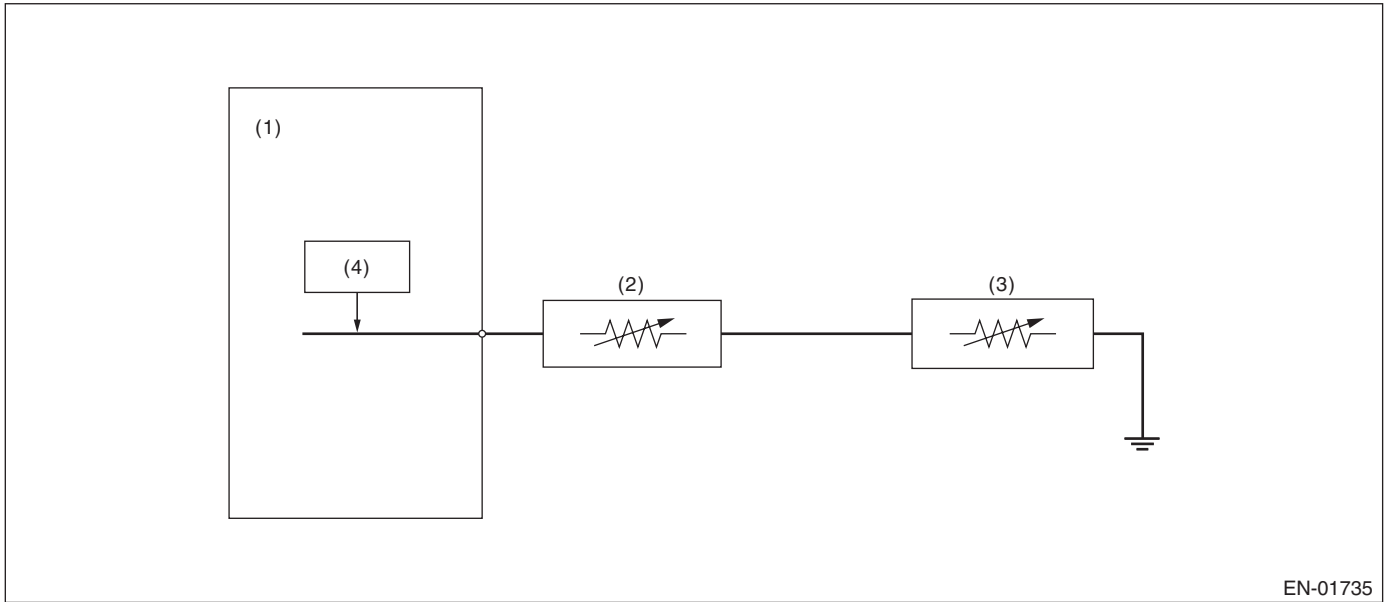

- (1) Engine control module (ECM)
- (2) Fuel level sensor
- (3) Fuel sub level sensor
- (4) Detecting circuit

#### 3. ENABLE CONDITION

Secondary Parameters	Enable Conditions
None	

#### 4. GENERAL DRIVING CYCLE

Always perform the diagnosis continuously.

# Diagnostic Trouble Code (DTC) Detecting Criteria

GENERAL DESCRIPTION

## 5. DIAGNOSTIC METHOD

### Abnormality Judgment

Judge as NG when the continuous time of meeting the malfunction criteria below becomes more than time needed for diagnosis (2.5 seconds).

### Judgment Value

Malfunction Criteria	Threshold Value
Ignition switch	ON
Battery voltage	$\geq 10.9$ V
After engine starting	3 seconds or more
Output voltage	$< 0.035$ V

**Time Needed for Diagnosis:** 2.5 seconds

**Malfunction Indicator Light Illumination:** Illuminates when malfunction occurs in 2 continuous driving cycles.

### Normality Judgment

Judge as OK and clear the NG when the malfunction criteria below are met.

### Judgment Value

Malfunction Criteria	Threshold Value
Ignition switch	ON
Battery voltage	$\geq 10.9$ V
After engine starting	3 seconds or more
Output voltage	$\geq 0.035$ V

## 6. DTC CLEAR CONDITION

- When the OK idling cycle is completed 40 times in a row
- When "Clear Memory" is performed

## 7. MALFUNCTION INDICATOR LIGHT CLEAR CONDITION

- When the OK driving cycle is completed 3 times in a row
- When "Clear Memory" is performed

## 8. FAIL SAFE

None

## 9. ECM OPERATION AT DTC SETTING

Memorize the freeze frame data. (For test mode \$02)

# Diagnostic Trouble Code (DTC) Detecting Criteria

## GENERAL DESCRIPTION

### BX:DTC P0463 FUEL LEVEL SENSOR "A" CIRCUIT HIGH

#### 1. OUTLINE OF DIAGNOSIS

Detect the open or short circuit of fuel level sensor.  
Judge as NG if it is out of specification.

#### 2. COMPONENT DESCRIPTION

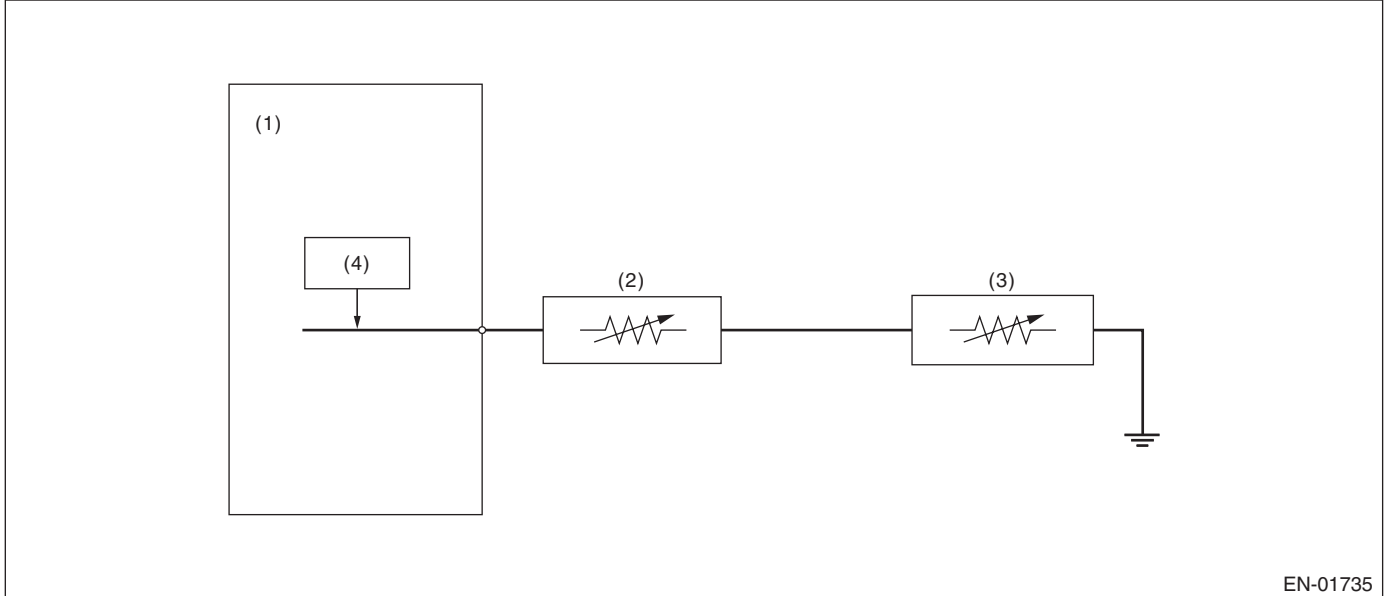

- (1) Engine control module (ECM)
- (2) Fuel level sensor
- (3) Fuel sub level sensor
- (4) Detecting circuit

#### 3. ENABLE CONDITION

Secondary Parameters	Enable Conditions
None	

#### 4. GENERAL DRIVING CYCLE

Always perform the diagnosis continuously.

# Diagnostic Trouble Code (DTC) Detecting Criteria

GENERAL DESCRIPTION

## 5. DIAGNOSTIC METHOD

### Abnormality Judgment

Judge as NG when the continuous time of meeting the malfunction criteria below exceeds the time required for diagnosis (10 seconds).

### Judgment Value

Malfunction Criteria	Threshold Value
Ignition switch	ON
Battery voltage	$\geq 10.9$ V
After engine starting	3 seconds or more
Output voltage	$\geq 4.911$ V

**Time Needed for Diagnosis:** 10 seconds

**Malfunction Indicator Light Illumination:** Illuminates when malfunction occurs in 2 continuous driving cycles.

### Normality Judgment

Judge as OK and clear the NG when the malfunction criteria below are met.

### Judgment Value

Malfunction Criteria	Threshold Value
Ignition switch	ON
Battery voltage	$\geq 10.9$ V
After engine starting	3 seconds or more
Output voltage	$< 4.911$ V

## 6. DTC CLEAR CONDITION

- When the OK idling cycle is completed 40 times in a row
- When "Clear Memory" is performed

## 7. MALFUNCTION INDICATOR LIGHT CLEAR CONDITION

- When the OK driving cycle is completed 3 times in a row
- When "Clear Memory" is performed

## 8. FAIL SAFE

None

## 9. ECM OPERATION AT DTC SETTING

Memorize the freeze frame data. (For test mode \$02)

# Diagnostic Trouble Code (DTC) Detecting Criteria

## GENERAL DESCRIPTION

---

### BY:DTC P0464 FUEL LEVEL SENSOR CIRCUIT INTERMITTENT

#### 1. OUTLINE OF DIAGNOSIS

Detect the unstable output faults from the fuel level sensor caused by noise. Judge as NG when the max. value and cumulative value of output voltage variation of the fuel level sensor is larger than the threshold value.

#### 2. ENABLE CONDITION

Malfunction Criteria	Threshold Value
Engine speed	≥ 500 rpm
After engine starting	1 second or more
Ignition switch	ON
Battery voltage	> 10.9 V
Idle switch	ON
Fuel level	9 — 51 ℓ (2.38 — 13.47 US gal, 1.98 — 11.22 Imp gal)
Vehicle speed = 0 km/h (0 MPH)	10 seconds or more

#### 3. GENERAL DRIVING CYCLE

- Always perform the diagnosis continuously at idle speed.
- Pay attention to the fuel level.



# Diagnostic Trouble Code (DTC) Detecting Criteria

GENERAL DESCRIPTION

## 4. DIAGNOSTIC METHOD

Calculate the Max. value (delflmax) and cumulative value (sumfl) of output voltage variation of fuel level sensor during 12.8 seconds. Judge it normal when both max. and cumulative values are not over the threshold value. Otherwise, when either of them is over the threshold value, the diagnosis counter counts up. Judge as NG if the counter indicated 4 counts.

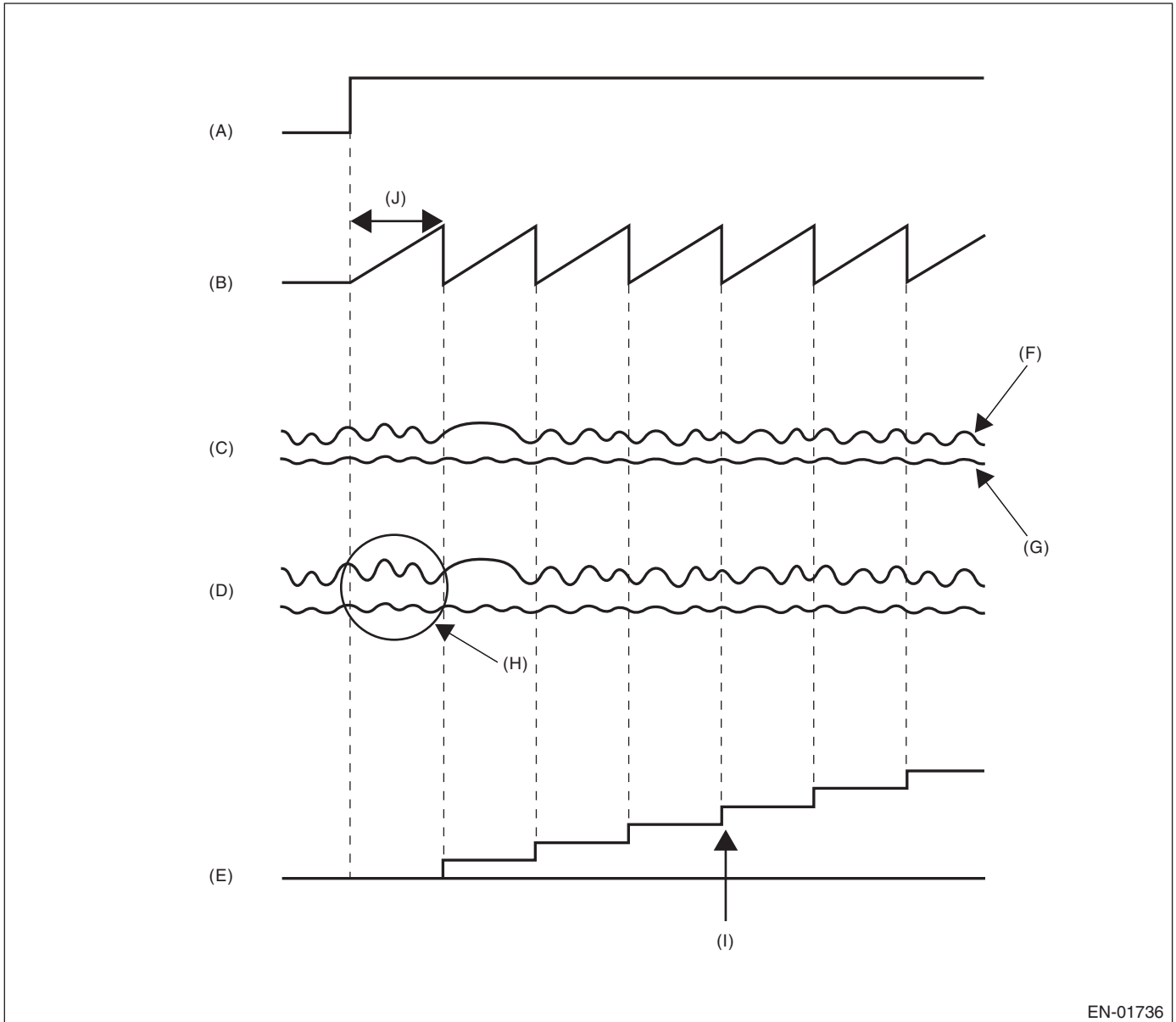

EN-01736

- |                                 |   |
|---------------------------------|---|
| (A) Diagnosis condition         | (G) Normal  |
| (B) Diagnosis period            | (H) The values of DVFLMAX and SUMVFL are regarded as maximum. |
| (C) Fuel level sensor A/D value | (I) NG 4 at counts  |
| (D) Fuel level output voltage   | (J) 12.8 seconds  |
| (E) Diagnosis counter           |   |
| (F) Malfunction                 |   |

# Diagnostic Trouble Code (DTC) Detecting Criteria

## GENERAL DESCRIPTION

---

### Abnormality Judgment

Judge as NG when the malfunction criteria below are met.

#### Judgment Value

Malfunction Criteria	Threshold Value
Total times of the condition reaching follows, DELFLMAX $\geq$ 0.228 V or SUMFL $\geq$ 21.8 V DELFLMAX is Max. deviation of sensor output during 12.8 seconds SUMFL: Integrated value of sensor output deviation in 12.8 seconds	$\geq$ 4 times

The diagnosis counter does not count up when the following conditions are completed within 12.8 seconds.

Maximum value – minimum value of change of tank pressure for 12.8 seconds	$\geq$ 0.05 kPa (0.375 mmHg, 0.01 inHg)
Maximum value – minimum value of battery voltage for 12.8 seconds	$\geq$ 0.465 V

**Time required for diagnosis:** 12.8 seconds  $\times$  4 times

**Malfunction Indicator Light Illumination:** Illuminates when malfunction occurs in 2 continuous driving cycles.

### Normality Judgment

Judge as OK and clear the NG when the malfunction criteria below are met.

#### Judgment Value

Malfunction Criteria	Threshold Value
DELFLMAX SUMFL DELFLMAX is Max. deviation of sensor output during 12.8 seconds SUMFL: Integrated value of sensor output deviation in 12.8 seconds	< 0.228 V < 21.8 V

## 5. DTC CLEAR CONDITION

- When the OK idling cycle is completed 40 times in a row
- When "Clear Memory" is performed

## 6. MALFUNCTION INDICATOR LIGHT CLEAR CONDITION

- When the OK driving cycle is completed 3 times in a row
- When "Clear Memory" is performed

## 7. FAIL SAFE

None

## 8. ECM OPERATION AT DTC SETTING

Memorize the freeze frame data. (For test mode \$02)

## BZ:DTC P0483 FAN RATIONALITY CHECK

### 1. OUTLINE OF DIAGNOSIS

Detect the function abnormality of the radiator fan.

Judge as NG when the engine coolant temperature slowly decreases even when the radiator fan is rotating.

### 2. ENABLE CONDITION

Diagnostic enable condition is established if the radiator fan changes from OFF → ON when all of the conditions below are met.

When one of the conditions below is not met, the diagnostic enable condition is not established.

Secondary Parameters	Enable Conditions
Engine speed	550 — 950 rpm
Idle switch	ON
Vehicle speed	0 km/h (0 MPH)
Battery voltage	≥ 10.9 V

### 3. GENERAL DRIVING CYCLE

Always perform the diagnosis continuously at idle speed.

### 4. DIAGNOSTIC METHOD

#### Abnormality Judgment

Judge as NG when the continuous time of meeting the malfunction criteria below becomes more than 5 minutes.

#### Judgment Value

Malfunction Criteria	Threshold Value
Engine coolant temperature	≥ 95°C (203°F)
Radiator fan	OFF → ON
Engine coolant temperature	Does not decrease

**Time Needed for Diagnosis:** 5 minutes

**Malfunction Indicator Light Illumination:** Illuminates when malfunction occurs in 2 continuous driving cycles.

#### Normality Judgment

Judge as OK and clear the NG when the malfunction criteria below are met.

#### Judgment Value

Malfunction Criteria	Threshold Value
Radiator fan	OFF → ON
Engine coolant temperature	Decreases

### 5. DTC CLEAR CONDITION

- When the OK idling cycle is completed 40 times in a row
- When “Clear Memory” is performed

### 6. MALFUNCTION INDICATOR LIGHT CLEAR CONDITION

- When the OK driving cycle is completed 3 times in a row
- When “Clear Memory” is performed

### 7. FAIL SAFE

None

### 8. ECM OPERATION AT DTC SETTING

Memorize the freeze frame data. (For test mode \$02)

# Diagnostic Trouble Code (DTC) Detecting Criteria

## GENERAL DESCRIPTION

---

### CA:DTC P0502 VEHICLE SPEED SENSOR “A” CIRCUIT LOW INPUT

#### 1. OUTLINE OF DIAGNOSIS

Detect the open or short circuit of vehicle speed. Judge NG when low vehicle speed (0 km/h (0 MPH)) remains whereas it seemed to be in a usual driving speed.

#### 2. ENABLE CONDITION

Secondary Parameters	Enable Conditions
Engine speed	< 4000 rpm
Fuel cut in decel.	In operation
Battery voltage	≥ 10.9 V

#### 3. GENERAL DRIVING CYCLE

Perform diagnosis continually during a deceleration fuel cut, at less than 4000 rpm.

#### 4. DIAGNOSTIC METHOD

##### Abnormality Judgment

Judge as NG when the continuous time of meeting the malfunction criteria below becomes 4 seconds or more.

##### Judgment Value

Malfunction Criteria	Threshold Value
Vehicle speed	< 1

**Time Needed for Diagnosis:** 4 seconds

**Malfunction Indicator Light Illumination:** Illuminates as soon as a malfunction occurs.

##### Normality Judgment

Judge as OK and clear the NG when all of the following criteria are established.

Malfunction Criteria	Threshold Value
Vehicle speed	≥ 1
Starter switch	OFF
Starter switch ON → OFF time	≥ 3 sec.

#### 5. DTC CLEAR CONDITION

- When the OK idling cycle is completed 40 times in a row
- When “Clear Memory” is performed

#### 6. MALFUNCTION INDICATOR LIGHT CLEAR CONDITION

- When the OK driving cycle is completed 3 times in a row
- When “Clear Memory” is performed

#### 7. FAIL SAFE

- Accelerator sensor signal process: Not allowed fully closed point learning. (Hold previous value)
- Vehicle speed sensor signal process: Vehicle speed = 10 km/h (6.21 MPH)
- Fuel cut control: Not allowed vehicle speed 0 km/h (0 MPH) fuel cut. Normally the high vehicle speed fuel cut performs on “and” of vehicle speed condition and engine speed, but perform the fuel cut only on engine speed condition (4,800 rpm or more).
- ISC control: Open loop compensation is set to (1 g/s). Not allowed ISC feedback volume calculation.
- Air conditioner control: Not allowed air conditioner cut at accelerating.
- Radiator fan control: Both main and sub fan are in High driving.
- Gear ratio judgment: Control as fixed in sixth gear
- Tumble generator valve control: Open the tumble generator valve.

#### 8. ECM OPERATION AT DTC SETTING

Memorize the freeze frame data. (For test mode \$02)

# Diagnostic Trouble Code (DTC) Detecting Criteria

GENERAL DESCRIPTION

## CB:DTC P0503 VEHICLE SPEED SENSOR “A” INTERMITTENT/ERRATIC/HIGH

### 1. OUTLINE OF DIAGNOSIS

Detect the open or short circuit of vehicle speed. Judge NG when high vehicle speed (300 km/h (186.4 MPH) or more) remains whereas it seemed to be in a usual driving speed.

### 2. ENABLE CONDITION

Secondary Parameters	Enable Conditions
Engine speed	< 4000 rpm
Fuel cut in decel.	In operation
Battery voltage	≥ 10.9 V

### 3. GENERAL DRIVING CYCLE

Perform diagnosis continually during a deceleration fuel cut, at less than 4000 rpm.

### 4. DIAGNOSTIC METHOD

#### Abnormality Judgment

Judge as NG when the continuous time of meeting the malfunction criteria below becomes 4 seconds or more.

#### Judgment Value

Malfunction Criteria	Threshold Value
Vehicle speed	≥ 300

**Time Needed for Diagnosis:** 4 seconds

**Malfunction Indicator Light Illumination:** Illuminates as soon as a malfunction occurs.

#### Normality Judgment

Judge as OK and clear the NG when all of the following criteria are established.

Malfunction Criteria	Threshold Value
Vehicle speed	< 300 km/h (186.4 MPH)
Starter switch	OFF
Starter switch ON → OFF time	≥ 3 sec.

### 5. DTC CLEAR CONDITION

- When the OK idling cycle is completed 40 times in a row
- When “Clear Memory” is performed

### 6. MALFUNCTION INDICATOR LIGHT CLEAR CONDITION

- When the OK driving cycle is completed 3 times in a row
- When “Clear Memory” is performed

### 7. FAIL SAFE

- Accelerator sensor signal process: Not allowed fully closed point learning. (Hold previous value)
- Vehicle speed sensor signal process: Vehicle speed = 10 km/h (6.21 MPH)
- Fuel cut control: Not allowed vehicle speed 0 km/h (0 MPH) fuel cut. Normally the high vehicle speed fuel cut performs on “and” of vehicle speed condition and engine speed, but perform the fuel cut only on engine speed condition (4,800 rpm or more).
- ISC control: Open loop compensation is set to (1 g/s). Not allowed ISC feedback volume calculation.
- Air conditioner control: Not allowed air conditioner cut at accelerating.
- Radiator fan control: Both main and sub fan are in High driving.
- Gear ratio judgment: Control as fixed in sixth gear
- Tumble generator valve control: Open the tumble generator valve.

### 8. ECM OPERATION AT DTC SETTING

Memorize the freeze frame data. (For test mode \$02)

# Diagnostic Trouble Code (DTC) Detecting Criteria

## GENERAL DESCRIPTION

### CC:DTC P0506 IDLE AIR CONTROL SYSTEM RPM LOWER THAN EXPECTED

#### 1. OUTLINE OF DIAGNOSIS

Detect the malfunction that actual engine speed is not close to target engine speed during idling. Judge as NG when actual engine speed is not close to target engine speed during idling.

#### 2. ENABLE CONDITION

Secondary Parameters	Enable Conditions
Engine coolant temperature	$\geq 70^{\circ}\text{C}$ (158°F)
Battery voltage	$\geq 10.9\text{ V}$
Atmospheric pressure	$> 75.0\text{ kPa}$ (563 mmHg, 22.2 inHg)
Fuel level	$\geq 9\text{ l}$ (2.38 US gal, 1.98 Imp gal)
After engine starting	10 seconds or more
Feedback in ISC	In operation
Lambda value	0.90 — 1.1
After air condition switching ON-OFF, OFF-ON	5 seconds or more
After intake manifold pressure changes more than 4 kPa (30 mmHg, 1.2 inHg).	$> 5\text{ sec.}$
After neutral switch ON-OFF change	$> 5\text{ sec.}$
Vehicle speed	0 km/h (0 MPH)

#### 3. GENERAL DRIVING CYCLE

After 10 seconds from engine starting, perform diagnosis continuously at idling after warming up.

#### 4. DIAGNOSTIC METHOD

##### Abnormality Judgment

Judge as NG when the continuous time of meeting the malfunction criteria below is 10 seconds  $\times$  3 times.

##### Judgment Value

Malfunction Criteria	Threshold Value
Actual — Target engine speed	$< -100\text{ rpm}$
Feedback value for ISC	Max.

**Time Needed for Diagnosis:** 10 seconds  $\times$  3 time

**Malfunction Indicator Light Illumination:** Illuminates when malfunction occurs in 2 continuous driving cycles.

##### Normality Judgment

Judge as OK and clear NG when the continuous time of meeting the malfunction criteria below becomes more than 10 seconds.

##### Judgment Value

Malfunction Criteria	Threshold Value
Actual — Target engine speed	$\geq -100\text{ rpm}$

#### 5. DTC CLEAR CONDITION

- When the OK idling cycle is completed 40 times in a row
- When “Clear Memory” is performed

#### 6. MALFUNCTION INDICATOR LIGHT CLEAR CONDITION

- When the OK driving cycle is completed 3 times in a row
- When “Clear Memory” is performed

# Diagnostic Trouble Code (DTC) Detecting Criteria

GENERAL DESCRIPTION

---

## 7. FAIL SAFE

- Judgment of heavy fuel: Not allowed to make the judgment of heavy fuel.
- Knock compensation:
  - Knock compensation final advance/delay angle value = knock compensation value + whole learning compensation value + portional learning compensation value
  - When normal: Knock compensation value = Fixed at 0°CA.
  - Failure: Knock compensation value ≠ Fixed at 0°CA. (When knock: Max. 12°CA retard)
  - Whole learning compensation coefficient update not allowed.
  - Portional learning zone compensation value calculation not allowed.

## 8. ECM OPERATION AT DTC SETTING

Memorize the freeze frame data. (For test mode \$02)

# Diagnostic Trouble Code (DTC) Detecting Criteria

## GENERAL DESCRIPTION

### CD:DTC P0507 IDLE AIR CONTROL SYSTEM RPM HIGHER THAN EXPECTED

#### 1. OUTLINE OF DIAGNOSIS

Detect the malfunction that actual engine speed is not close to target engine speed during idling. Judge as NG when actual engine speed is not close to target engine speed during idling.

#### 2. ENABLE CONDITION

Secondary Parameters	Enable Conditions
Engine coolant temperature	≥ 70°C (158°F)
Battery voltage	≥ 10.9 V
Atmospheric pressure	> 75.0 kPa (563 mmHg, 22.2 inHg)
Fuel level	≥ 9 ℓ (2.38 US gal, 1.98 Imp gal)
After engine starting	10 seconds or more
Feedback in ISC	In operation
Lambda value	0.90 — 1.1
After air condition switching ON-OFF, OFF-ON	5 seconds or more
After intake manifold pressure changes more than 4 kPa (30 mmHg, 1.2 inHg).	> 5 sec.
After neutral switch ON-OFF change	> 5 sec.
Vehicle speed	0 km/h (0 MPH)

#### 3. GENERAL DRIVING CYCLE

After 10 seconds from engine starting, perform diagnosis continuously at idling after warming up.

#### 4. DIAGNOSTIC METHOD

##### Abnormality Judgment

Judge as NG when the continuous time of meeting the malfunction criteria below is 10 seconds × 3 times.

##### Judgment Value

Malfunction Criteria	Threshold Value
Actual – Target engine speed	≥ 200 rpm
Feedback value for ISC	Min.

**Time Needed for Diagnosis:** 10 seconds × 3 time

**Malfunction Indicator Light Illumination:** Illuminates when malfunction occurs in 2 continuous driving cycles.

##### Normality Judgment

Judge as OK and clear NG when the continuous time of meeting the malfunction criteria below becomes more than 10 seconds.

##### Judgment Value

Malfunction Criteria	Threshold Value
Actual – Target engine speed	< 200 rpm

#### 5. DTC CLEAR CONDITION

- When the OK idling cycle is completed 40 times in a row
- When “Clear Memory” is performed

#### 6. MALFUNCTION INDICATOR LIGHT CLEAR CONDITION

- When the OK driving cycle is completed 3 times in a row
- When “Clear Memory” is performed



# Diagnostic Trouble Code (DTC) Detecting Criteria

GENERAL DESCRIPTION

---

## 7. FAIL SAFE

- Judgment of heavy fuel: Not allowed to make the judgment of heavy fuel.
- Knock compensation:
  - Knock compensation final advance/delay angle value = knock compensation value + whole learning compensation value + portional learning compensation value
  - When normal: Knock compensation value = Fixed at 0°CA.
  - Failure: Knock compensation value ≠ Fixed at 0°CA. (When knock: Max. 12°CA retard)
  - Whole learning compensation coefficient update not allowed.
  - Portional learning zone compensation value calculation not allowed.

## 8. ECM OPERATION AT DTC SETTING

Memorize the freeze frame data. (For test mode \$02)

# Diagnostic Trouble Code (DTC) Detecting Criteria

## GENERAL DESCRIPTION

---

### CE:DTC P0512 STARTER REQUEST CIRCUIT

#### 1. OUTLINE OF DIAGNOSIS

Detect the open or short circuit of starter SW.

Judge ON NG when the starter SW signal remains ON.

Judge OFF NG when the engine starts without starter experience.

#### 2. ENABLE CONDITION

Secondary Parameters	Enable Conditions
None	

#### 3. GENERAL DRIVING CYCLE

Always perform the diagnosis continuously.

#### 4. DIAGNOSTIC METHOD

##### Abnormality Judgment

Judge as ON NG when the continuous time of meeting the malfunction criteria below becomes more than 3 minutes.

##### Judgment Value

Malfunction Criteria	Threshold Value
Engine speed	> 500 rpm
Starter OFF signal	Not detected
Battery voltage	> 8 V

**Time Needed for Diagnosis:** 180 seconds

**Malfunction Indicator Light Illumination:** Illuminates when malfunction occurs in 2 continuous driving cycles.

##### Normality Judgment

Judge ON OK and clear the NG when the malfunction criteria below are met.

##### Judgment Value

Malfunction Criteria	Threshold Value
Starter switch	OFF
Battery voltage	> 8 V

#### 5. DTC CLEAR CONDITION

- When the OK idling cycle is completed 40 times in a row
- When "Clear Memory" is performed

#### 6. MALFUNCTION INDICATOR LIGHT CLEAR CONDITION

- When the OK driving cycle is completed 3 times in a row
- When "Clear Memory" is performed

#### 7. FAIL SAFE

None

#### 8. ECM OPERATION AT DTC SETTING

Memorize the freeze frame data. (For test mode \$02)

# Diagnostic Trouble Code (DTC) Detecting Criteria

GENERAL DESCRIPTION

## CF:DTC P0513 INCORRECT IMMOBILIZER KEY

### 1. OUTLINE OF DIAGNOSIS

DTC	Item	OUTLINE OF DIAGNOSIS
P0513	Incorrect Immobilizer Key	Incorrect immobilizer key (Use of unregistered key in IMMCM)
P1570	Antenna	Faulty antenna
P1571	Reference Code Incompatibility	Reference code incompatibility between IMMCM and ECM
P1572	IMM Circuit Failure (Except Antenna Circuit)	Communication failure between IMMCM and ECM
P1574	Key Communication Failure	Failure of IMMCM to verify key (transponder) ID code or transponder failure
P1576	EGI Control Module EEPROM	ECM malfunctioning
P1577	IMM Control Module EEPROM	IMMCM malfunctioning

### 2. ENABLE CONDITION

When starting the engine.

### 3. GENERAL DRIVING CYCLE

Perform the diagnosis only after starting the engine.

### 4. DIAGNOSTIC METHOD

Judge as NG when the conditions of the diagnosis outline above are established.

# Diagnostic Trouble Code (DTC) Detecting Criteria

## GENERAL DESCRIPTION

---

### CG:DTC P0519 IDLE AIR CONTROL SYSTEM PERFORMANCE

#### 1. OUTLINE OF DIAGNOSIS

Detect the malfunction that engine speed increases more than that in normal condition during idling.

#### 2. ENABLE CONDITION

Secondary Parameters	Enable Conditions
Battery voltage	$\geq 10.9$ V
Feedback in ISC	In operation
Vehicle speed	$< 4$ km/h (2.49 MPH)
After engine starting	1 second or more

#### 3. GENERAL DRIVING CYCLE

Perform the diagnosis continuously if the vehicle speed at less than 4 km/h (2.49 MPH).

#### 4. DIAGNOSTIC METHOD

##### Abnormality Judgment

Judge as NG when the continuous time of meeting the all malfunction criteria below becomes more than 2 seconds.

##### Judgment Value

Malfunction Criteria	Threshold Value
Engine speed — targeted engine speed	$\geq 1500$ rpm
Feedback value for ISC	$\leq 0\%$
Engine speed change every 180 degree engine revs.	$\geq -5$ rpm

**Time Needed for Diagnosis:** 2 seconds

**Malfunction Indicator Light Illumination:** Illuminates as soon as a malfunction occurs.

##### Normality Judgment

Judge as OK and clear NG when the continuous time of meeting the malfunction criteria below becomes more than 5 seconds.

##### Judgment Value

Malfunction Criteria	Threshold Value
Engine speed — targeted engine speed	$< 200$ rpm

#### 5. DTC CLEAR CONDITION

- When the OK idling cycle is completed 40 times in a row
- When "Clear Memory" is performed

#### 6. MALFUNCTION INDICATOR LIGHT CLEAR CONDITION

- When the OK driving cycle is completed 3 times in a row
- When "Clear Memory" is performed

#### 7. FAIL SAFE

Fuel cut: Cuts off fuel for only #1 and #2 cylinders, or for all cylinders according to vehicle speed, engine speed, and throttle position.

#### 8. ECM OPERATION AT DTC SETTING

Memorize the freeze frame data. (For test mode \$02)

## CH:DTC P0600 SERIAL COMMUNICATION LINK

### 1. OUTLINE OF DIAGNOSIS

Detect malfunction of CAN communication.

Judge as NG when CAN communication is not established, CAN communication with AT is not established, and the data from the AT is not normal.

### 2. COMPONENT DESCRIPTION

ECM and TCM are connected by high speed CAN.

#### *(Common Specifications)*

***CAN Protocol 2.0 B (Active)***

***Frame Format: 11 Bit ID Frame (Standard Frame)***

#### *(High speed CAN)*

***Conforms to ISO11898***

***Communication Speed: 500 kbps***

### 3. ENABLE CONDITION

Secondary Parameters	Enable Conditions
Battery voltage	≥ 10.9 V
Starter switch	OFF
Engine	run

### 4. GENERAL DRIVING CYCLE

Perform the diagnosis continuously after starting the engine.

### 5. DIAGNOSTIC METHOD

#### Abnormality Judgment

Judge as NG when either of the following conditions is established.

Judge as OK and clear the NG when the continuous time when all of the following criteria are established is more than the predetermined time (1 second).

#### Judgment Value

Malfunction Criteria	Threshold Value
bus off flag or warning flag	set
ID is not received from the TCM	= 500 milliseconds

**Time Needed for Diagnosis:** 1 second

**Malfunction Indicator Light Illumination:** Illuminates as soon as a malfunction occurs.

### 6. DTC CLEAR CONDITION

- When the OK idling cycle is completed 40 times in a row
- When "Clear Memory" is performed

### 7. MALFUNCTION INDICATOR LIGHT CLEAR CONDITION

- When the OK driving cycle is completed 3 times in a row
- When "Clear Memory" is performed

### 8. FAIL SAFE

None

### 9. ECM OPERATION AT DTC SETTING

Memorize the freeze frame data. (For test mode \$02)

# Diagnostic Trouble Code (DTC) Detecting Criteria

## GENERAL DESCRIPTION

---

### CI: DTC P0604 INTERNAL CONTROL MODULE RANDOM ACCESS MEMORY (RAM) ERROR

#### 1. OUTLINE OF DIAGNOSIS

Detect the malfunction of microcomputer (RAM).

Zero clear all normal RAM areas with the initial routine, and judge as NG when the sum of all added RAM after clearing is other than zero.

#### 2. ENABLE CONDITION

Secondary Parameters	Enable Conditions
Ignition switch	OFF → ON

Diagnosis with the initial routine.

#### 3. GENERAL DRIVING CYCLE

Perform the diagnosis as soon as the ignition switch is turned to ON.

#### 4. DIAGNOSTIC METHOD

Judge as NG when the criteria below are met and judge as OK when not met, and clear the NG.

##### Judgment Value

Malfunction Criteria	Threshold Value
Sum of RAM data after data clear	Cannot be read.

**Time Needed for Diagnosis:** Undetermined

**Malfunction Indicator Light Illumination:** Illuminates as soon as a malfunction occurs.

#### 5. DTC CLEAR CONDITION

- When the OK idling cycle is completed 40 times in a row
- When "Clear Memory" is performed

#### 6. MALFUNCTION INDICATOR LIGHT CLEAR CONDITION

- When the OK driving cycle is completed 3 times in a row
- When "Clear Memory" is performed

#### 7. FAIL SAFE

None

#### 8. ECM OPERATION AT DTC SETTING

Memorize the freeze frame data. (For test mode \$02)

## CJ:DTC P0605 INTERNAL CONTROL MODULE READ ONLY MEMORY (ROM) ERROR

### 1. OUTLINE OF DIAGNOSIS

Judge as NG when SUM value of ROM is outside the standard value.

### 2. ENABLE CONDITION

Secondary Parameters	Enable Conditions
Ignition switch	ON

### 3. GENERAL DRIVING CYCLE

Always perform the diagnosis continuously.

### 4. DIAGNOSTIC METHOD

#### Abnormality Judgment

Judge as NG when the continuous time of meeting the malfunction criteria below becomes 0.5 seconds or more.

#### Judgment Value

Malfunction Criteria	Threshold Value
SUM value of ROM	Specification

**Time Needed for Diagnosis:** Undetermined

**Malfunction Indicator Light Illumination:** Illuminates as soon as a malfunction occurs.

### 5. DTC CLEAR CONDITION

- When the OK idling cycle is completed 40 times in a row
- When "Clear Memory" is performed (Only with engine stopped)

### 6. MALFUNCTION INDICATOR LIGHT CLEAR CONDITION

- When the OK driving cycle is completed 3 times in a row
- When "Clear Memory" is performed (Only with engine stopped)

### 7. FAIL SAFE

Stop the continuity to the electronic throttle control motor. (Throttle opening is fixed to 6°.)

### 8. ECM OPERATION AT DTC SETTING

- Memorize the freeze frame data. (For test mode \$02)

# Diagnostic Trouble Code (DTC) Detecting Criteria

## GENERAL DESCRIPTION

### CK:DTC P0607 CONTROL MODULE PERFORMANCE

#### 1. OUTLINE OF DIAGNOSIS

Judge as NG when either the following is completed.

- When the read value of throttle position sensor 1 signal is mismatched between main CPU and sub CPU.
- When the read value of accelerator pedal position sensor 1 signal is mismatched between main CPU and sub CPU.
- When the sub CPU operates abnormally.
- When the communication between main CPU  $\leftrightarrow$  sub CPU is abnormal.
- When the input amplifier circuit of throttle position sensor 1 is abnormal.
- When the cruise control cannot be canceled correctly.
- When the signal of brake SW1 and 2 is mismatched.
- When the directed angle from the main CPU is abnormal.

#### 2. COMPONENT DESCRIPTION

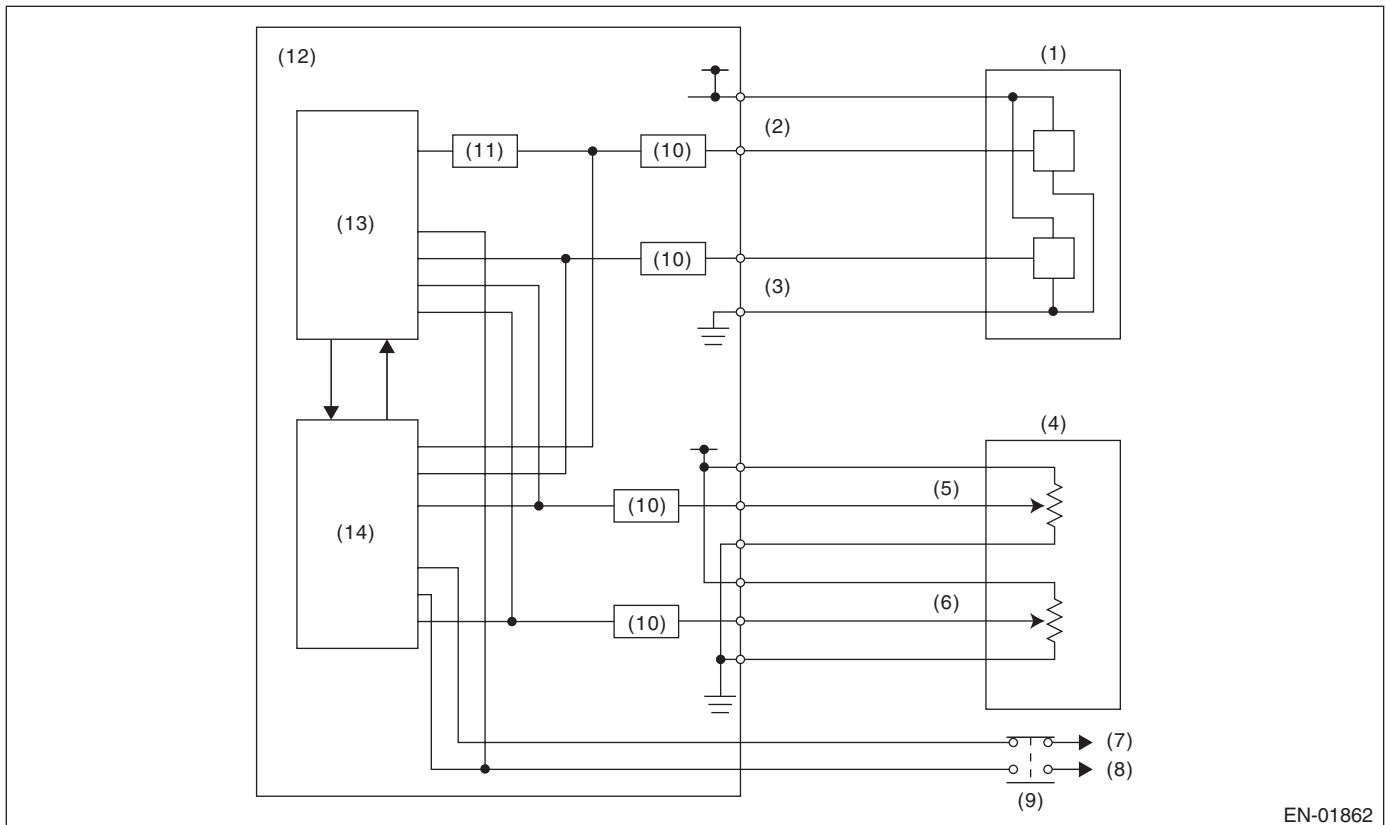

EN-01862

- |   |                                  |
|---|----------------------------------|
| (1) Throttle position sensor            | (8) Stop light                   |
| (2) Throttle position sensor 1          | (9) Brake switch                 |
| (3) Throttle position sensor 2          | (10) I/F circuit                 |
| (4) Accelerator pedal position sensor   | (11) Amplifier circuit           |
| (5) Accelerator pedal position sensor 1 | (12) Engine control module (ECM) |
| (6) Accelerator pedal position sensor 2 | (13) Sub CPU                     |
| (7) Battery                             | (14) Main CPU                    |



# Diagnostic Trouble Code (DTC) Detecting Criteria

GENERAL DESCRIPTION

## 3. ENABLE CONDITION

Secondary Parameters	Enable Conditions
(1) Ignition switch	ON
(2) Ignition switch	ON
(3) None	—
(4) None	—
(5) Throttle opening angle	
(6) Brake switch (only with cruise control)	ON
(7) None	—

## 4. GENERAL DRIVING CYCLE

- (1) — (4): Always perform the diagnosis continuously.  
(5): Always perform the diagnosis continuously when idling.  
(6): Perform the diagnosis when the brake pedal is depressed.  
(7): Always perform the diagnosis continuously.

## 5. DIAGNOSTIC METHOD

Judge as OK and clear the NG when the malfunction criteria below are met.

### Judgment Value

Malfunction Criteria	Threshold Value
1. Difference of CPU on reading value of throttle position sensor signal	Within 0.858 V
2. Difference of CPU on read value of accelerator pedal position sensor signal	Within 0.042 V
3. WD pulse from sub CPU	WD pulse occur
4. Communication between CPU	Possible to communicate
5. Difference of signal on connection of amplifier	Within X $4\pm 3^\circ$
6. Cruise control cancel signal at brake ON	Cruise control cancel signal ON
7. Brake switch 1, 2 signal	SW 1 and 2 are matched

### Time Needed for Diagnosis:

1. 250 milliseconds
2. 250 milliseconds
3. 200 milliseconds
4. 200 milliseconds
5. 24 milliseconds
6. 250 milliseconds
7. 200 milliseconds

**Malfunction Indicator Light Illumination:** Illuminates as soon as a malfunction occurs.

## 6. DTC CLEAR CONDITION

- When the OK idling cycle is completed 40 times in a row
- When "Clear Memory" is performed

## 7. MALFUNCTION INDICATOR LIGHT CLEAR CONDITION

- When the OK driving cycle is completed 3 times in a row
- When "Clear Memory" is performed

## 8. FAIL SAFE

Stop the continuity to the electronic throttle control motor. (Throttle opening is fixed to  $6^\circ$ .)

## 9. ECM OPERATION AT DTC SETTING

Memorize the freeze frame data. (For test mode \$02)

# Diagnostic Trouble Code (DTC) Detecting Criteria

## GENERAL DESCRIPTION

### CL:DTC P0638 THROTTLE ACTUATOR CONTROL RANGE/PERFORMANCE (BANK 1)

#### 1. OUTLINE OF DIAGNOSIS

Judge as NG when the target opening angle and actual opening angle is mismatched or the current to motor is more than specified duty for specified time continuously.

#### 2. COMPONENT DESCRIPTION

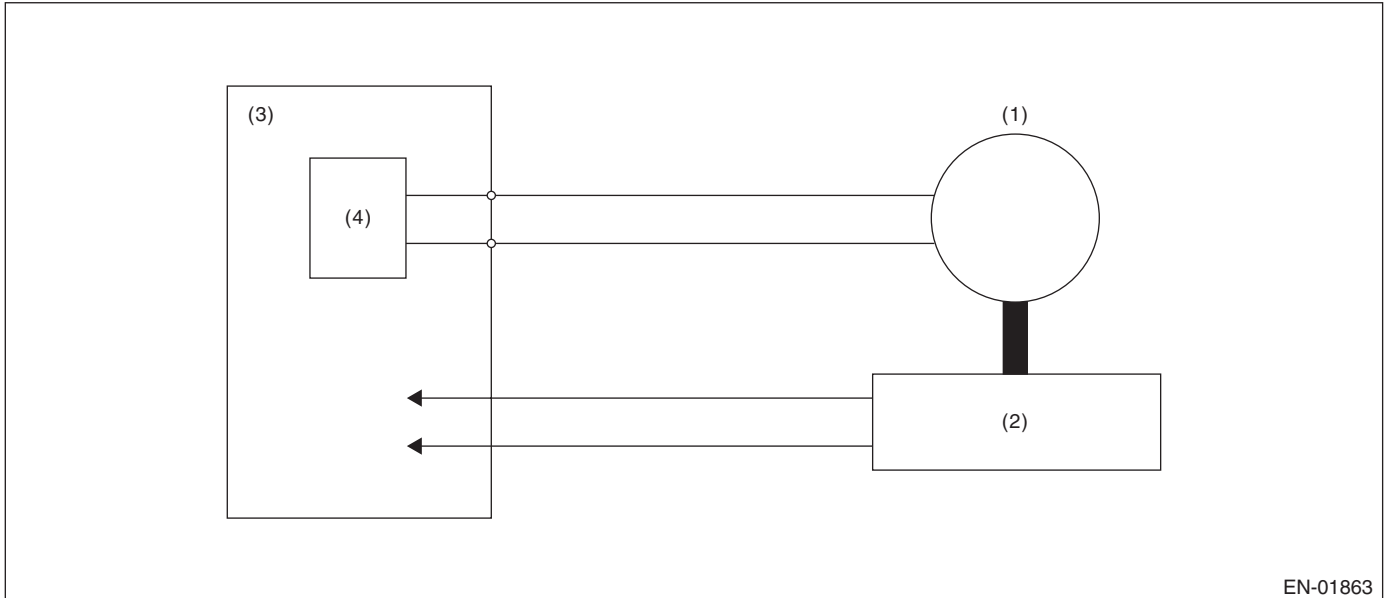

- (1) Motor
- (2) Throttle position sensor
- (3) Engine control module (ECM)
- (4) Drive circuit

#### 3. ENABLE CONDITION

Secondary Parameters	Enable Conditions
Ignition switch	ON
Normal operation of electric throttle control	ON

#### 4. GENERAL DRIVING CYCLE

Always perform the diagnosis continuously when the electric throttle control is operating.

# Diagnostic Trouble Code (DTC) Detecting Criteria

GENERAL DESCRIPTION

## 5. DIAGNOSTIC METHOD

Judge as OK and clear the NG when the malfunction criteria below are met.

### Judgment Value

Malfunction Criteria	Threshold Value
Difference between target opening angle and actual opening angle	3.5° or less
Output duty to drive circuit	95% or less

### Time Needed for Diagnosis:

- Target opening angle and actual opening angle: 250 milliseconds (For NG) 2000 milliseconds (For OK)
- Output duty to drive circuit: 2000 milliseconds

### Details of Judgment Value

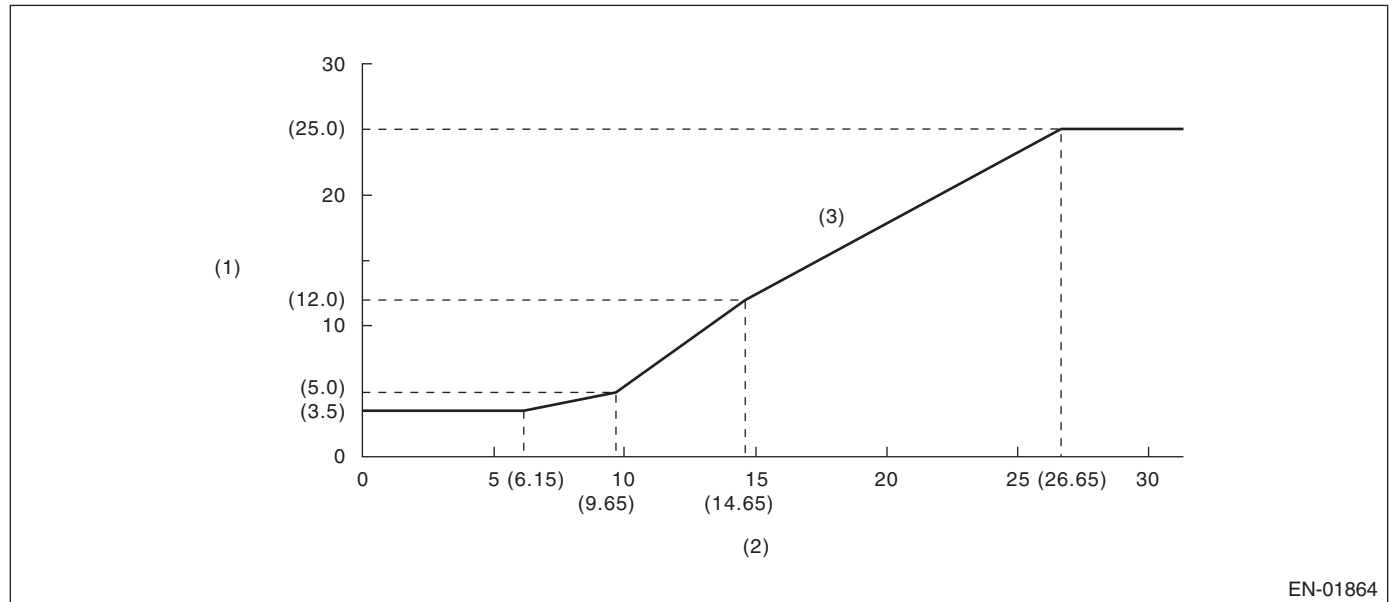

EN-01864

- (1) Difference between target opening angle and actual opening angle (°)
- (2) Target throttle opening angle (°)
- (3) NG area

# Diagnostic Trouble Code (DTC) Detecting Criteria

## GENERAL DESCRIPTION

**Details of Judgment** (The actual opening angle  $\leq$  target opening angle is always 1000 milliseconds)

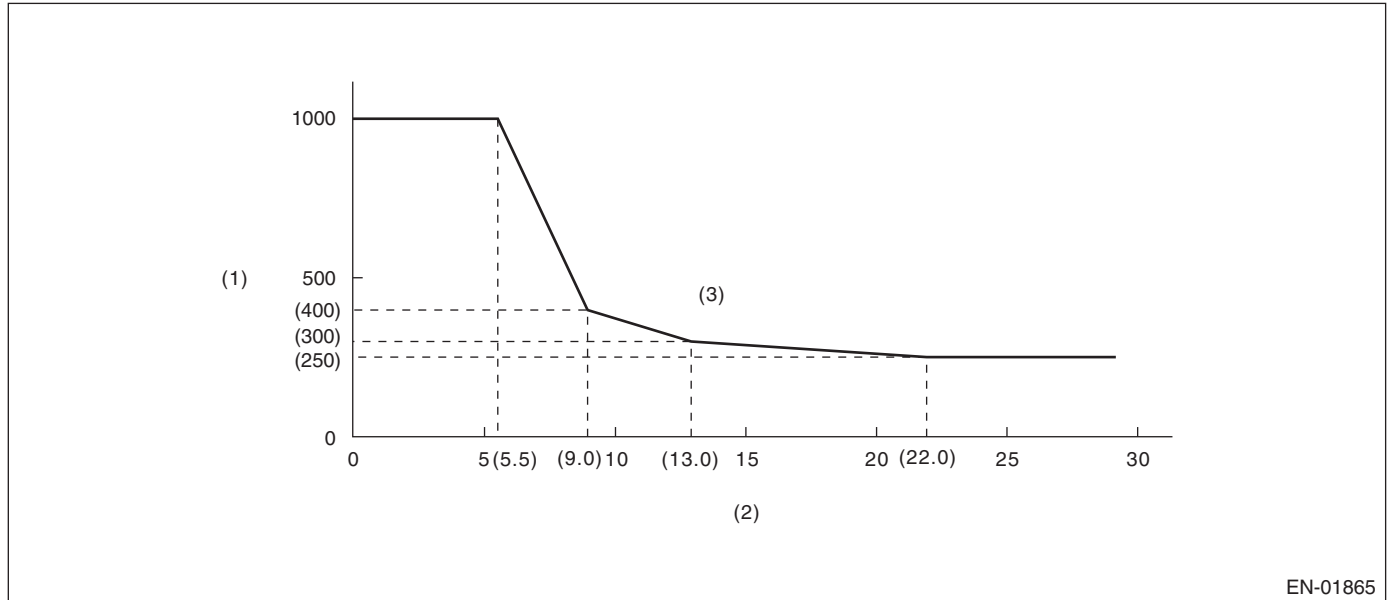

- (1) Judgment time (milliseconds)
- (2) Throttle position sensor 1 opening angle
- (3) NG area

**Malfunction Indicator Light Illumination:** Illuminates as soon as a malfunction occurs.

## 6. DTC CLEAR CONDITION

- When the OK idling cycle is completed 40 times in a row
- When "Clear Memory" is performed (Only with engine stopped)

## 7. MALFUNCTION INDICATOR LIGHT CLEAR CONDITION

- When the OK driving cycle is completed 3 times in a row
- When "Clear Memory" is performed (Only with engine stopped)

## 8. FAIL SAFE

Stop the continuity to the electronic throttle control motor. (Throttle opening is fixed to 6°.)

## 9. ECM OPERATION AT DTC SETTING

Memorize the freeze frame data. (For test mode \$02)

# Diagnostic Trouble Code (DTC) Detecting Criteria

GENERAL DESCRIPTION

## CM:DTC P0691 FAN 1 CONTROL CIRCUIT LOW

### 1. OUTLINE OF DIAGNOSIS

Detect the open/short circuit of radiator fan circuit.

Judge as NG when the ECM output level differs from the actual terminal level.

### 2. ENABLE CONDITION

Secondary Parameters	Enable Conditions
None	

### 3. GENERAL DRIVING CYCLE

Always perform the diagnosis continuously.

### 4. DIAGNOSTIC METHOD

#### Abnormality Judgment

Judge as NG when the continuous time of meeting the malfunction criteria below becomes more than 2.5 seconds.

#### Judgment Value

Malfunction Criteria	Threshold Value
After engine starting	1 second or more
Engine speed	≥ 500 rpm
Ignition switch	ON
Battery voltage	≥ 10.9 V
Terminal voltage level when ECM outputs OFF signal	Low level

**Time Needed for Diagnosis:** 2.5 seconds

**Malfunction Indicator Light Illumination:** Illuminates when malfunction occurs in 2 continuous driving cycles.

#### Normality Judgment

Judge as OK and clear the NG when the malfunction criteria below are met.

#### Judgment Value

Malfunction Criteria	Threshold Value
After engine starting	1 second or more
Engine speed	≥ 500 rpm
Ignition switch	ON
Battery voltage	≥ 10.9 V
Terminal voltage level when ECM outputs OFF signal	High level

### 5. DTC CLEAR CONDITION

- When the OK idling cycle is completed 40 times in a row
- When "Clear Memory" is performed

### 6. MALFUNCTION INDICATOR LIGHT CLEAR CONDITION

- When the OK driving cycle is completed 3 times in a row
- When "Clear Memory" is performed

### 7. FAIL SAFE

None

### 8. ECM OPERATION AT DTC SETTING

Memorize the freeze frame data. (For test mode \$02)

# Diagnostic Trouble Code (DTC) Detecting Criteria

## GENERAL DESCRIPTION

---

### CN:DTC P0692 FAN 1 CONTROL CIRCUIT HIGH

#### 1. OUTLINE OF DIAGNOSIS

Detect the open/short circuit of radiator fan circuit.

Judge as NG when the ECM output level differs from the actual terminal level.

#### 2. ENABLE CONDITION

Secondary Parameters	Enable Conditions
None	

#### 3. GENERAL DRIVING CYCLE

Always perform the diagnosis continuously.

#### 4. DIAGNOSTIC METHOD

##### Abnormality Judgment

Judge as NG when the continuous time of meeting the malfunction criteria below becomes more than 2.5 seconds.

##### Judgment Value

Malfunction Criteria	Threshold Value
After engine starting	1 second or more
Engine speed	≥ 500 rpm
Ignition switch	ON
Battery voltage	≥ 10.9 V
Terminal voltage level when ECM outputs ON signal	High level

**Time Needed for Diagnosis:** 2.5 seconds

**Malfunction Indicator Light Illumination:** Illuminates when malfunction occurs in 2 continuous driving cycles.

##### Normality Judgment

Judge as OK and clear the NG when the malfunction criteria below are met.

##### Judgment Value

Malfunction Criteria	Threshold Value
After engine starting	1 second or more
Engine speed	≥ 500 rpm
Ignition switch	ON
Battery voltage	≥ 10.9 V
Terminal voltage level when ECM outputs ON signal	Low level

#### 5. DTC CLEAR CONDITION

- When the OK idling cycle is completed 40 times in a row
- When "Clear Memory" is performed

#### 6. MALFUNCTION INDICATOR LIGHT CLEAR CONDITION

- When the OK driving cycle is completed 3 times in a row
- When "Clear Memory" is performed

#### 7. FAIL SAFE

None

#### 8. ECM OPERATION AT DTC SETTING

Memorize the freeze frame data. (For test mode \$02)

# Diagnostic Trouble Code (DTC) Detecting Criteria

GENERAL DESCRIPTION

## CO:DTC P0700 TRANSMISSION CONTROL SYSTEM (MIL REQUEST)

### 1. OUTLINE OF DIAGNOSIS

CAN communication is established with AT and, judge as NG when there is a MIL lighting request.

### 2. ENABLE CONDITION

Secondary Parameters	Enable Conditions
Battery voltage	$\geq 10.9$ V

### 3. GENERAL DRIVING CYCLE

Always perform the diagnosis continuously.

### 4. DIAGNOSTIC METHOD

Judge as NG when the continuous time of meeting the malfunction criteria below becomes longer than the predetermined amount of time (2.5 seconds).

Judge as OK and clear the NG when the following conditions are not met.

#### Judgment Value

Malfunction Criteria	Threshold Value
MIL lighting request from TCM	set

**Time Needed for Diagnosis:** 2.5 seconds

**Malfunction Indicator Light Illumination:** Illuminates as soon as a malfunction occurs.

### 5. DTC CLEAR CONDITION

- When the OK idling cycle is completed 40 times in a row
- When "Clear Memory" is performed

### 6. MALFUNCTION INDICATOR LIGHT CLEAR CONDITION

- When the OK driving cycle is completed 3 times in a row
- When "Clear Memory" is performed

### 7. FAIL SAFE

None

### 8. ECM OPERATION AT DTC SETTING

Memorize the freeze frame data. (For test mode \$02)

# Diagnostic Trouble Code (DTC) Detecting Criteria

## GENERAL DESCRIPTION

---

### CP:DTC P0851 PARK/NEUTRAL SWITCH INPUT CIRCUIT LOW (AT MODEL)

#### 1. OUTLINE OF DIAGNOSIS

Detect the open or short circuit of the neutral SW.

Judge NG when the ECM neutral terminal input differs from the reception data from TCM.

#### 2. ENABLE CONDITION

Secondary Parameters	Enable Conditions
Ignition switch	ON
Battery voltage	≥ 10.9 V
After engine starting	2 seconds or more
Starter switch	OFF

#### 3. GENERAL DRIVING CYCLE

Perform the diagnosis continuously in 2 seconds after starting the engine.

#### 4. DIAGNOSTIC METHOD

Judge as NG when the continuous time until meeting the malfunction criteria below becomes more than 6.5 seconds. Judge as OK and clear the NG when the malfunction criteria below are not met.

##### Judgment Value

Malfunction Criteria	Threshold Value
Neutral switch signal when park/neutral = "OFF" and any other switches = "ON" on AT	LOW (ON)

**Time Needed for Diagnosis:** 6.5 seconds

**Malfunction Indicator Light Illumination:** Illuminates when malfunction occurs in 2 continuous driving cycles.

#### 5. DTC CLEAR CONDITION

- When the OK idling cycle is completed 40 times in a row
- When "Clear Memory" is performed

#### 6. MALFUNCTION INDICATOR LIGHT CLEAR CONDITION

- When the OK driving cycle is completed 3 times in a row
- When "Clear Memory" is performed

#### 7. FAIL SAFE

None

#### 8. ECM OPERATION AT DTC SETTING

Memorize the freeze frame data. (For test mode \$02)



# Diagnostic Trouble Code (DTC) Detecting Criteria

GENERAL DESCRIPTION

## CQ:DTC P0851 NEUTRAL SWITCH INPUT CIRCUIT LOW (MT MODEL)

### 1. OUTLINE OF DIAGNOSIS

Judge the open or short circuit of the neutral SW.

Judge NG when there is no change in the neutral SW even if the driving shift was applied. (There is neutral SW ON/OFF inversion from the vehicle speed and engine speed.)

### 2. ENABLE CONDITION

Secondary Parameters	Enable Conditions
Ignition switch	ON
Battery voltage	≥ 10.9 V
After engine starting	2 seconds or more
Starter switch	OFF

### 3. GENERAL DRIVING CYCLE

Perform the diagnosis continuously in 2 seconds after starting the engine.

### 4. DIAGNOSTIC METHOD

Judge NG when the malfunction criteria below are completed 3 time or more after the neutral SW change. And clear NG if there is change in the neutral SW.

#### Judgment Value

Malfunction Criteria	Threshold Value
Neutral switch signal (while changing from a to b below)	Low continues
Driving condition change	a) to b)
a) Vehicle speed = 0 km/h (0 MPH) and engine speed 600 — 900 rpm	
b) Vehicle speed ≥ 64 km/h (39.8 MPH) and engine speed 1600 — 2550 rpm	

**Time Needed for Diagnosis:** Monitoring 3 times

**Malfunction Indicator Light Illumination:** Illuminates when malfunction occurs in 2 continuous driving cycles.

### 5. DTC CLEAR CONDITION

- When the OK idling cycle is completed 40 times in a row
- When “Clear Memory” is performed

### 6. MALFUNCTION INDICATOR LIGHT CLEAR CONDITION

- When the OK driving cycle is completed 3 times in a row
- When “Clear Memory” is performed

### 7. FAIL SAFE

Cruise control: Not allowed to command cruise control.

### 8. ECM OPERATION AT DTC SETTING

Memorize the freeze frame data. (For test mode \$02)

# Diagnostic Trouble Code (DTC) Detecting Criteria

## GENERAL DESCRIPTION

---

### CR:DTC P0852 PARK/NEUTRAL SWITCH INPUT CIRCUIT HIGH (AT MODEL)

#### 1. OUTLINE OF DIAGNOSIS

Judge the open or short circuit of the neutral SW.

Judge NG when the ECM neutral terminal input differs from the reception data from TCM.

#### 2. ENABLE CONDITION

Secondary Parameters	Enable Conditions
Ignition switch	ON
Battery voltage	≥ 10.9 V
After engine starting	2 seconds or more
Starter switch	OFF

#### 3. GENERAL DRIVING CYCLE

Perform the diagnosis continuously in 2 seconds after starting the engine.

#### 4. DIAGNOSTIC METHOD

Judge as NG when the continuous time of meeting the malfunction criteria below becomes 6.5 seconds.

Judge as OK and clear the NG when the malfunction criteria below are not met.

#### Judgment Value

Malfunction Criteria	Threshold Value
Neutral switch signal when park/neutral = "ON" and any other switches = "OFF" on AT	HIGH (OFF)

**Time Needed for Diagnosis:** 6.5 seconds

**Malfunction Indicator Light Illumination:** Illuminates when malfunction occurs in 2 continuous driving cycles.

#### 5. DTC CLEAR CONDITION

- When the OK idling cycle is completed 40 times in a row
- When "Clear Memory" is performed

#### 6. MALFUNCTION INDICATOR LIGHT CLEAR CONDITION

- When the OK driving cycle is completed 3 times in a row
- When "Clear Memory" is performed

#### 7. FAIL SAFE

None

#### 8. ECM OPERATION AT DTC SETTING

Memorize the freeze frame data. (For test mode \$02)

# Diagnostic Trouble Code (DTC) Detecting Criteria

GENERAL DESCRIPTION

## CS:DTC P0852 NEUTRAL SWITCH INPUT CIRCUIT HIGH (MT MODEL)

### 1. OUTLINE OF DIAGNOSIS

Judge the open or short circuit of the neutral SW.

Judge NG when there is no change in the neutral SW even if the driving shift was applied. (There is neutral SW ON/OFF inversion from the vehicle speed and engine speed.)

### 2. ENABLE CONDITION

Secondary Parameters	Enable Conditions
Ignition switch	ON
Battery voltage	≥ 10.9 V
After engine starting	2 seconds or more
Starter switch	OFF

### 3. GENERAL DRIVING CYCLE

Perform the diagnosis continuously in 2 seconds after starting the engine.

### 4. DIAGNOSTIC METHOD

Judge NG when the malfunction criteria below are completed 3 time or more after the neutral SW change. And clear NG if there is change in the neutral SW.

#### Judgment Value

Malfunction Criteria	Threshold Value
Neutral switch signal (while changing from a to b below)	High continues
Driving condition change	a) to b)
a) Vehicle speed = 0 km/h (0 MPH) and engine speed 600 — 900 rpm	
b) Vehicle speed ≥ 64 km/h (39.8 MPH) and engine speed 1600 — 2550 rpm	

**Time Needed for Diagnosis:** Monitoring 3 times

**Malfunction Indicator Light Illumination:** Illuminates when malfunction occurs in 2 continuous driving cycles.

### 5. DTC CLEAR CONDITION

- When the OK idling cycle is completed 40 times in a row
- When “Clear Memory” is performed

### 6. MALFUNCTION INDICATOR LIGHT CLEAR CONDITION

- When the OK driving cycle is completed 3 times in a row
- When “Clear Memory” is performed

### 7. FAIL SAFE

None

### 8. ECM OPERATION AT DTC SETTING

Memorize the freeze frame data. (For test mode \$02)

# Diagnostic Trouble Code (DTC) Detecting Criteria

## GENERAL DESCRIPTION

### CT:DTC P1152 O2 SENSOR CIRCUIT RANGE/PERFORMANCE (LOW) (BANK 1 SENSOR 1)

#### 1. OUTLINE OF DIAGNOSIS

Detect that  $\lambda$  value remains Low.

Judge as NG when lambda value is abnormal in accordance with  $\lambda$  value of front oxygen (A/F) sensor and running conditions such as vehicle speed, amount of intake air, engine coolant temperature, sub feedback control, etc.

$\lambda$  value = Actual air fuel ratio/Theoretical air fuel ratio

$\lambda > 1$ : Lean

$\lambda < 1$ : Rich

#### 2. COMPONENT DESCRIPTION

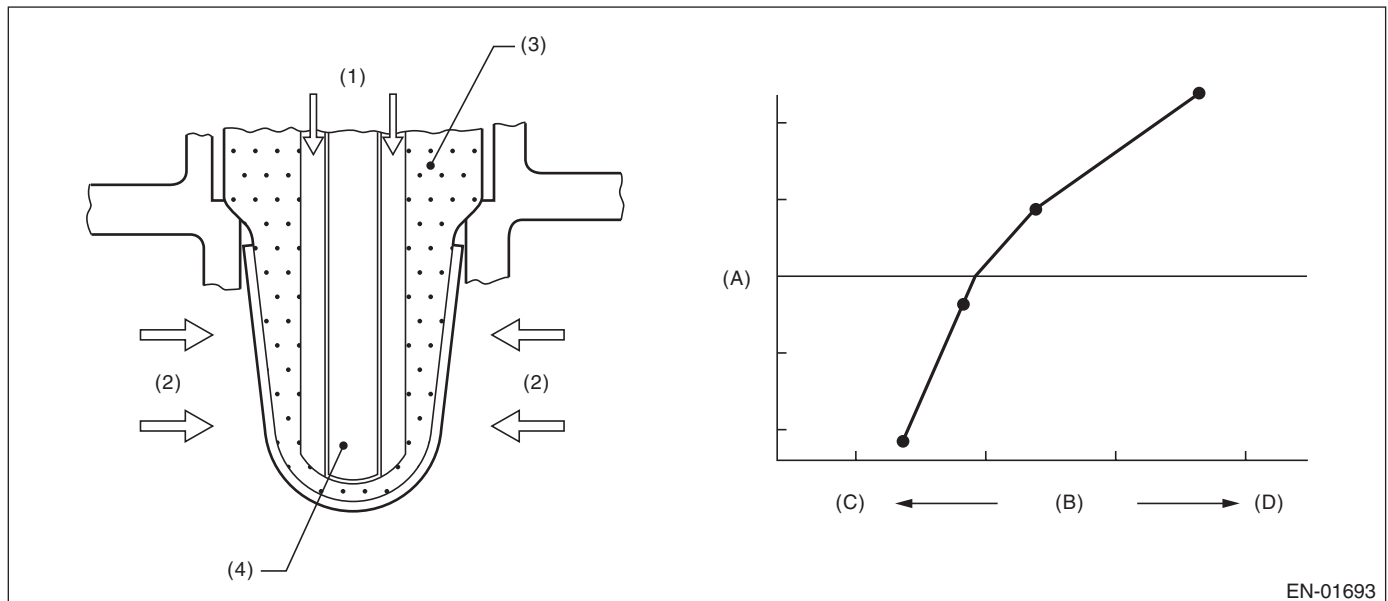

- (1) Atmosphere
- (2) Exhaust gas
- (3) ZrO<sub>2</sub>
- (4) Ceramic heater

- (A) Electromotive force
- (B) Air fuel ratio
- (C) Lean
- (D) Rich

EN-01693

# Diagnostic Trouble Code (DTC) Detecting Criteria

GENERAL DESCRIPTION

## 3. ENABLE CONDITION

Secondary Parameters	Enable Conditions
All secondary parameters enable conditions	4 seconds or more
Battery voltage	> 10.9 V
Atmosphere pressure	> 75.0 kPa (563 mmHg, 22.2 inHg)
Rear oxygen sensor sub feedback	Execution
Rear oxygen sensor output voltage – Feedback target voltage	–0.2 V — 0.1 V
or	
Rear oxygen sensor sub feedback compensation coefficient	On Min.
or	
Rear oxygen sensor sub feedback compensation coefficient	On Max.
After engine starting	60 seconds or more
Engine coolant temperature	≥ 70°C (158°F)
Vehicle speed	≥ 20 km/h (12.4 MPH)
Amount of intake air	≥ 6 g/s
Load change during 0.5 engine revs.	≤ 0.01 g/rev
Front oxygen (A/F) sensor impedance	0 — 50 Ω
Learning value of evaporation gas density	≤ 0.2
Total time of operating canister purge	20 seconds or more

## 4. GENERAL DRIVING CYCLE

Perform diagnosis continuously at a constant speed of 20 km/h (12 MPH) or more, from 60 seconds after starting the engine.

## 5. DIAGNOSTIC METHOD

Judge as NG when the continuous time of meeting the malfunction criteria below becomes more than 10 seconds. Judge as OK and clear the NG when the malfunction criteria below are not met.

### Judgment Value

Malfunction Criteria	Threshold Value
λ value when rear oxygen sensor sub feedback compensation coefficient is not at maximum limit	≤ 0.85

**Time Needed for Diagnosis:** 10 seconds

**Malfunction Indicator Light Illumination:** Illuminates when malfunction occurs in 2 continuous driving cycles.

## 6. DTC CLEAR CONDITION

- When the OK idling cycle is completed 40 times in a row
- When “Clear Memory” is performed

## 7. MALFUNCTION INDICATOR LIGHT CLEAR CONDITION

- When the OK driving cycle is completed 3 times in a row
- When “Clear Memory” is performed

## 8. FAIL SAFE

- Front oxygen (A/F) sensor main learning compensation: Not allowed to calculate.
- Correction when re-starting at high temperature: Normally minimum value 0.3 → 0.
- Purge control: Not allowed to purge.

## 9. ECM OPERATION AT DTC SETTING

Memorize the freeze frame data. (For test mode \$02)

# Diagnostic Trouble Code (DTC) Detecting Criteria

## GENERAL DESCRIPTION

### CU:DTC P1153 O2 SENSOR CIRCUIT RANGE/PERFORMANCE (HIGH) (BANK 1 SENSOR 1)

#### 1. OUTLINE OF DIAGNOSIS

Detect that  $\lambda$  value remains High.

Judge as NG when lambda value is abnormal in accordance with  $\lambda$  value of front oxygen (A/F) sensor and running conditions such as vehicle speed, amount of intake air, engine coolant temperature, sub feedback control, etc.

$\lambda$  value = Actual air fuel ratio/Theoretical air fuel ratio

$\lambda > 1$ : Lean

$\lambda < 1$ : Rich

#### 2. COMPONENT DESCRIPTION

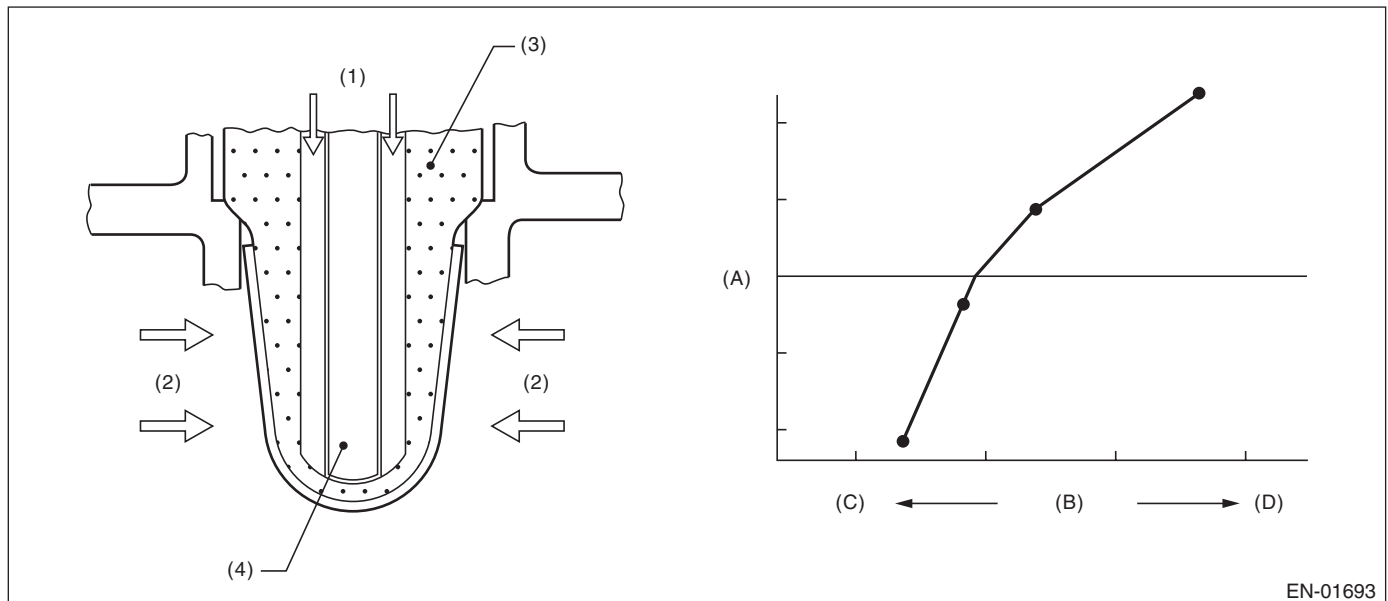

- (1) Atmosphere
- (2) Exhaust gas
- (3) ZrO<sub>2</sub>
- (4) Ceramic heater

- (A) Electromotive force
- (B) Air fuel ratio
- (C) Lean
- (D) Rich

EN-01693

# Diagnostic Trouble Code (DTC) Detecting Criteria

GENERAL DESCRIPTION

## 3. ENABLE CONDITION

Secondary Parameters	Enable Conditions
All secondary parameters enable conditions	4 seconds or more
Battery voltage	> 10.9 V
Atmospheric pressure	> 75.0 kPa (563 mmHg, 22.2 inHg)
Rear oxygen sensor sub feedback	Execution
Rear oxygen sensor output voltage – Feedback target voltage	–0.2 V — 0.1 V
or	
Rear oxygen sensor sub feedback compensation coefficient	On Min.
or	
Rear oxygen sensor sub feedback compensation coefficient	On Max.
After engine starting	60 seconds or more
Engine coolant temperature	≥ 70°C (158°F)
Vehicle speed	≥ 20 km/h (12.4 MPH)
Amount of intake air	≥ 6 g/s
Load change during 0.5 engine revs.	≤ 0.02 g/rev
Front oxygen (A/F) sensor impedance	0 — 50 Ω
Learning value of evaporation gas density	≤ 0.2
Total time of operating canister purge	20 seconds or more

## 4. GENERAL DRIVING CYCLE

Perform diagnosis continuously at a constant vehicle speed of 20 km/h (12 MPH) or more, from 60 seconds after starting the engine.

## 5. DIAGNOSTIC METHOD

Judge as NG when the continuous time of meeting the malfunction criteria below becomes more than 10 seconds. Judge as OK and clear the NG when the malfunction criteria below are not met.

### Judgment Value

Malfunction Criteria	Threshold Value
λ value when rear oxygen sensor sub feedback compensation coefficient cannot be at minimum limit	≥ 1.15

**Time Needed for Diagnosis:** 10 seconds

**Malfunction Indicator Light Illumination:** Illuminates when malfunction occurs in 2 continuous driving cycles.

## 6. DTC CLEAR CONDITION

- When the OK idling cycle is completed 40 times in a row
- When “Clear Memory” is performed

## 7. MALFUNCTION INDICATOR LIGHT CLEAR CONDITION

- When the OK driving cycle is completed 3 times in a row
- When “Clear Memory” is performed

## 8. FAIL SAFE

- Front oxygen (A/F) sensor main learning compensation: Not allowed to calculate.
- Correction when re-starting at high temperature: Normally minimum value 0.3 → 0.
- Purge control: Not allowed to purge.

## 9. ECM OPERATION AT DTC SETTING

Memorize the freeze frame data. (For test mode \$02)

# Diagnostic Trouble Code (DTC) Detecting Criteria

## GENERAL DESCRIPTION

### CV:DTC P1160 RETURN SPRING FAILURE

#### 1. OUTLINE OF DIAGNOSIS

Judge as NG when the valve does not move to the close direction with the motor power stopped and the valve open more than the default opening.

#### 2. COMPONENT DESCRIPTION

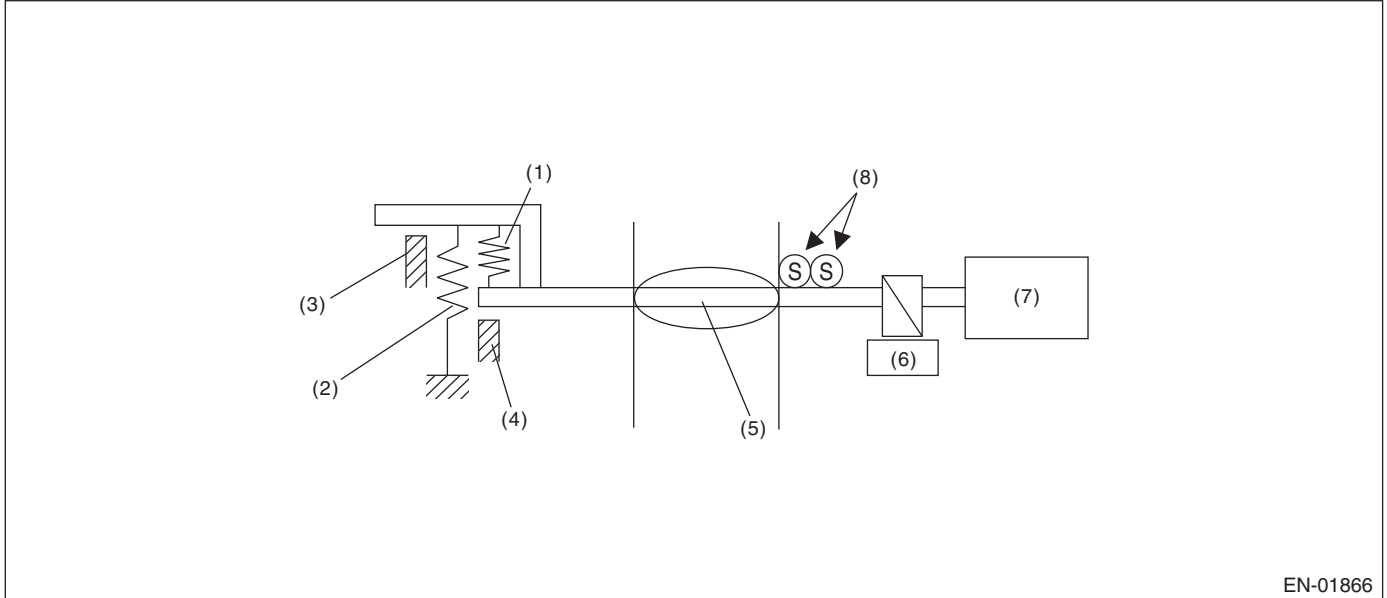

(1) Opener spring

(2) Return spring

(3) Intermediate stopper

(4) Full closed stopper

(5) Throttle valve

(6) Gear

(7) DC motor

(8) Main and sub throttle sensor

#### 3. ENABLE CONDITION

Secondary Parameters	Enable Conditions
Throttle opening angle	OFF
Motor continuity	OFF

#### 4. GENERAL DRIVING CYCLE

- Ignition switch ON → OFF
- Ignition switch OFF → ON (Only after clearing memory)

#### 5. DIAGNOSTIC METHOD

##### Abnormality Judgment

Judge as NG when the continuous time of meeting the malfunction criteria below becomes 0.6 seconds or more.

##### Judgment Value

Malfunction Criteria	Threshold Value
Opening variation after continuity is set to OFF	< 2°

**Time Needed for Diagnosis:** 600 milliseconds

**Malfunction Indicator Light Illumination:** Illuminates as soon as a malfunction occurs.



# Diagnostic Trouble Code (DTC) Detecting Criteria

GENERAL DESCRIPTION

---

## 6. DTC CLEAR CONDITION

- When the OK idling cycle is completed 40 times in a row
- When "Clear Memory" is performed (Only with engine stopped)

## 7. MALFUNCTION INDICATOR LIGHT CLEAR CONDITION

- When the OK driving cycle is completed 3 times in a row
- When "Clear Memory" is performed (Only with engine stopped)

## 8. FAIL SAFE

Throttle opening is fixed to 6°.

## 9. ECM OPERATION AT DTC SETTING

Memorize the freeze frame data. (For test mode \$02)

# Diagnostic Trouble Code (DTC) Detecting Criteria

## GENERAL DESCRIPTION

### CW:DTC P1400 FUEL TANK PRESSURE CONTROL SOLENOID VALVE CIRCUIT LOW

#### 1. OUTLINE OF DIAGNOSIS

Detect the open/short circuit of pressure control solenoid valve.

Judge as NG when ECM output level is different from actual terminal level.

#### 2. COMPONENT DESCRIPTION

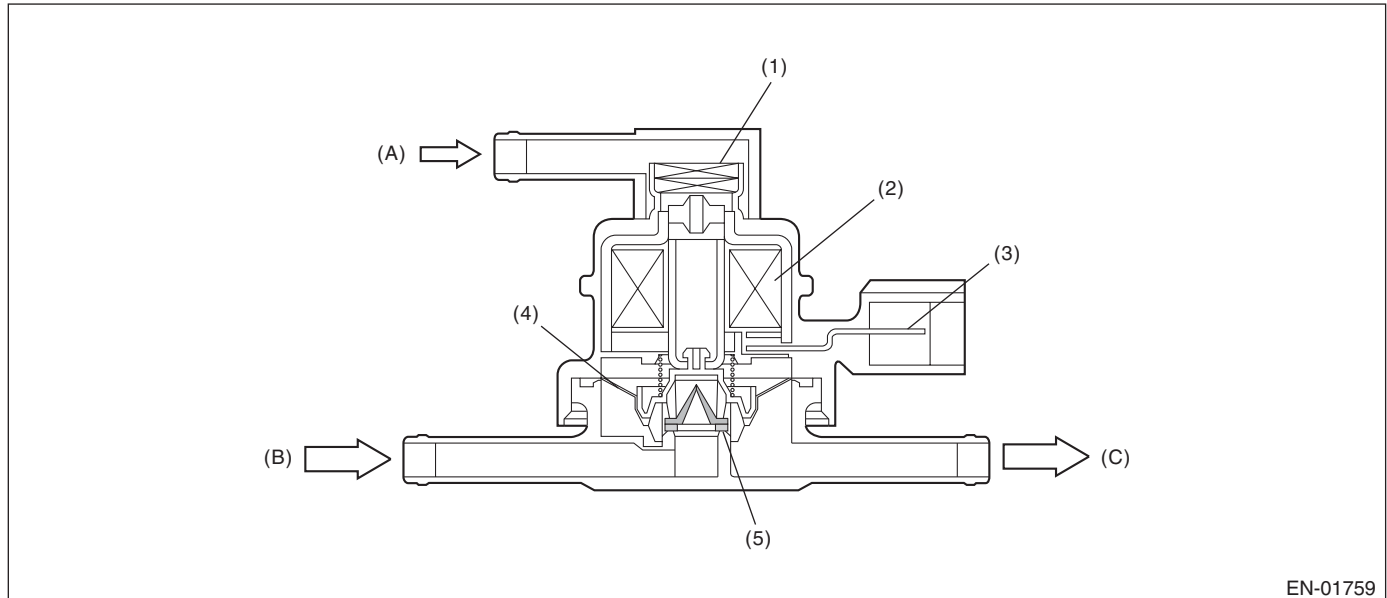

- (1) Filter
- (2) Coil
- (3) Connector terminal
- (4) Diaphragm
- (5) Valve

- (A) Atmospheric pressure
- (B) Shut-off valve
- (C) To fuel tank

#### 3. ENABLE CONDITION

Secondary Parameters	Enable Conditions
Ignition switch	ON
Battery voltage	$\geq 10.9$ V
After engine starting	1 second or more

#### 4. GENERAL DRIVING CYCLE

Always perform the diagnosis after starting the engine.

#### 5. DIAGNOSTIC METHOD

Judge as NG when the continuous time of meeting the malfunction criteria below becomes more than time needed for diagnosis (2.5 seconds). Judge as OK and clear the NG when the malfunction criteria below are not met.

##### Judgment Value

Malfunction Criteria	Threshold Value
Terminal output voltage when ECM outputs OFF signal	Low

**Time Needed for Diagnosis:** 2.5 seconds

**Malfunction Indicator Light Illumination:** Illuminates when malfunction occurs in 2 continuous driving cycles.

# Diagnostic Trouble Code (DTC) Detecting Criteria

GENERAL DESCRIPTION

---

## 6. DTC CLEAR CONDITION

- When the OK idling cycle is completed 40 times in a row
- When "Clear Memory" is performed

## 7. MALFUNCTION INDICATOR LIGHT CLEAR CONDITION

- When the OK driving cycle is completed 3 times in a row
- When "Clear Memory" is performed

## 8. FAIL SAFE

None

## 9. ECM OPERATION AT DTC SETTING

Memorize the freeze frame data. (For test mode \$02)

# Diagnostic Trouble Code (DTC) Detecting Criteria

## GENERAL DESCRIPTION

### CX:DTC P1410 SECONDARY AIR INJECTION SYSTEM SWITCHING VALVE STUCK OPEN

#### 1. OUTLINE OF DIAGNOSIS

Continually detects for a combination solenoid valve and lead valve stuck open condition. Calculate the integrated value of secondary air supply piping pressure sensor output voltage maximum/minimum values and output voltage deviation for a constant time period after engine start, and if the difference between the maximum/minimum is large and the integrated value is also large, judge as NG.

#### 2. ENABLE CONDITION

Secondary Parameters	Enable Conditions
Engine speed	< 500 rpm
After engine starting	9 seconds or more
After secondary air injection system stop	9 seconds or more
Amount of intake air	2 g (0.07 oz)/seconds or more and Less than 400 g (14.11 oz)/seconds
Battery voltage	≥ 10.9 V

#### 3. GENERAL DRIVING CYCLE

Perform diagnosis continuously after engine start with the secondary air pump stopped and with a high air flow amount.

#### 4. DIAGNOSTIC METHOD

When the solenoid and lead valves of the combination valve both are open and malfunctioning, a pulse will appear in the secondary air supply piping pressure sensor output. This pulse is tracked by the following method to detect the problem.

Calculate the maximum and minimum values of the secondary air supply piping pressure sensor output voltage, and integrated value (sum) of the output voltage deviation for kCOTIM seconds. The difference between the maximum/minimum values is compared with the threshold value, and the sum is also compared with the threshold value. If both exceed the threshold, the NG counter is counted up, and when the counter becomes kCOCOT times, an NG judgment is made. If neither exceed the threshold, or only one exceeds the threshold, it is judged as being normal.

#### Judgment Value

Malfunction Criteria	Threshold Value
Pipe inner pressure difference between Max. and Min.	≥ 0.048 V
Cumulative pipe inner pressure change per 4 milliseconds	≥ 24 V
Amount of atmospheric pressure change	< 4 mmHg

**Time Needed for Diagnosis:** 10 seconds × 2 time

**Malfunction Indicator Light Illumination:** Illuminates as soon as a malfunction occurs.

#### 5. DTC CLEAR CONDITION

- When the OK idling cycle is completed 40 times in a row
- When "Clear Memory" is performed

#### 6. MALFUNCTION INDICATOR LIGHT CLEAR CONDITION

- When the OK driving cycle is completed 3 times in a row
- When "Clear Memory" is performed

#### 7. FAIL SAFE

None

#### 8. ECM OPERATION AT DTC SETTING

Memorize the freeze frame data. (For test mode \$02)

# Diagnostic Trouble Code (DTC) Detecting Criteria

GENERAL DESCRIPTION

## CY:DTC P1418 SECONDARY AIR INJECTION SYSTEM CONTROL "A" CIRCUIT SHORTED

### 1. OUTLINE OF DIAGNOSIS

Judge as NG when the ECM output level differs from the actual terminal level.

### 2. ENABLE CONDITION

Secondary Parameters	Enable Conditions
None	

### 3. GENERAL DRIVING CYCLE

Always perform the diagnosis continuously.

### 4. DIAGNOSTIC METHOD

#### Abnormality Judgment

When the continuous time with following conditions being established exceeds 2.5 seconds, it is judged as NG.

#### Judgment Value

Malfunction Criteria	Threshold Value
Battery voltage	$\geq 10.9$ V
Ignition	ON
Terminal output voltage when ECM outputs ON signal	High

**Time Needed for Diagnosis:** 2.5 seconds

**Malfunction Indicator Light Illumination:** Illuminates as soon as a malfunction occurs.

#### Normality Judgment

Judge as OK when the following conditions are established, and clear the NG.

#### Judgment Value

Malfunction Criteria	Threshold Value
Battery voltage	$\geq 10.9$ V
Ignition	ON
Terminal output voltage when ECM outputs ON signal	Low

### 5. DTC CLEAR CONDITION

- When the OK idling cycle is completed 40 times in a row
- When "Clear Memory" is performed

### 6. MALFUNCTION INDICATOR LIGHT CLEAR CONDITION

- When the OK driving cycle is completed 3 times in a row
- When "Clear Memory" is performed

### 7. FAIL SAFE

None

### 8. ECM OPERATION AT DTC SETTING

Memorize the freeze frame data. (For test mode \$02)

# Diagnostic Trouble Code (DTC) Detecting Criteria

## GENERAL DESCRIPTION

### CZ:DTC P1420 FUEL TANK PRESSURE CONTROL SOL. VALVE CIRCUIT HIGH

#### 1. OUTLINE OF DIAGNOSIS

Detect the open/short circuit of pressure control solenoid valve.

Judge as NG when ECM output level is different from actual terminal level.

#### 2. COMPONENT DESCRIPTION

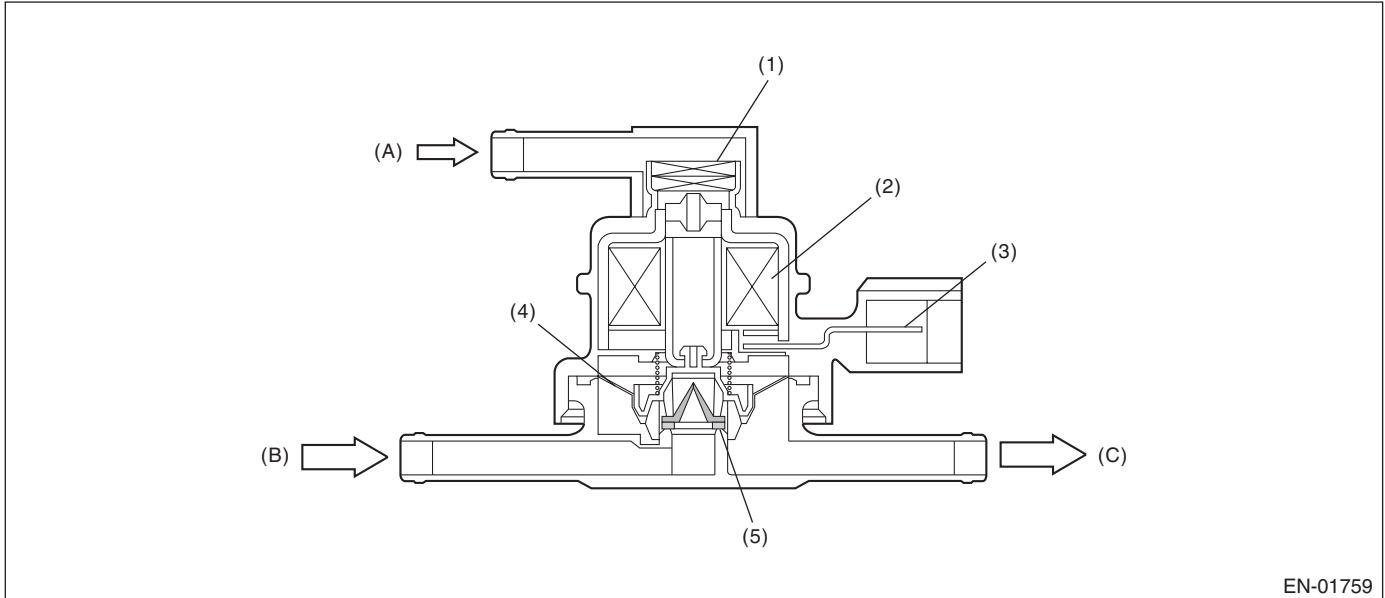

- (1) Filter
- (2) Coil
- (3) Connector terminal
- (4) Diaphragm
- (5) Valve

- (A) Atmospheric pressure
- (B) Shut-off valve
- (C) To fuel tank

#### 3. ENABLE CONDITION

Secondary Parameters	Enable Conditions
Ignition switch	ON
Battery voltage	$\geq 10.9\text{ V}$
After engine starting	1 second or more

#### 4. GENERAL DRIVING CYCLE

Always perform the diagnosis after starting the engine.

# Diagnostic Trouble Code (DTC) Detecting Criteria

GENERAL DESCRIPTION

## 5. DIAGNOSTIC METHOD

Judge as NG when the continuous time of meeting the malfunction criteria below becomes more than time needed for diagnosis (2.5 seconds). Judge as OK and clear the NG when the malfunction criteria below are not met.

### Judgment Value

Malfunction Criteria	Threshold Value
Terminal output voltage when ECM outputs ON signal	High

**Time Needed for Diagnosis:** 2.5 seconds

**Malfunction Indicator Light Illumination:** Illuminates when malfunction occurs in 2 continuous driving cycles.

## 6. DTC CLEAR CONDITION

- When the OK idling cycle is completed 40 times in a row
- When "Clear Memory" is performed

## 7. MALFUNCTION INDICATOR LIGHT CLEAR CONDITION

- When the OK driving cycle is completed 3 times in a row
- When "Clear Memory" is performed

## 8. FAIL SAFE

None

## 9. ECM OPERATION AT DTC SETTING

Memorize the freeze frame data. (For test mode \$02)

# Diagnostic Trouble Code (DTC) Detecting Criteria

## GENERAL DESCRIPTION

### DA:DTC P1443 VENT CONTROL SOLENOID VALVE FUNCTION PROBLEM

#### 1. OUTLINE OF DIAGNOSIS

Detect the abnormal function (stuck closed) of the drain valve.  
Judge as NG when fuel tank pressure is low.

#### 2. COMPONENT DESCRIPTION

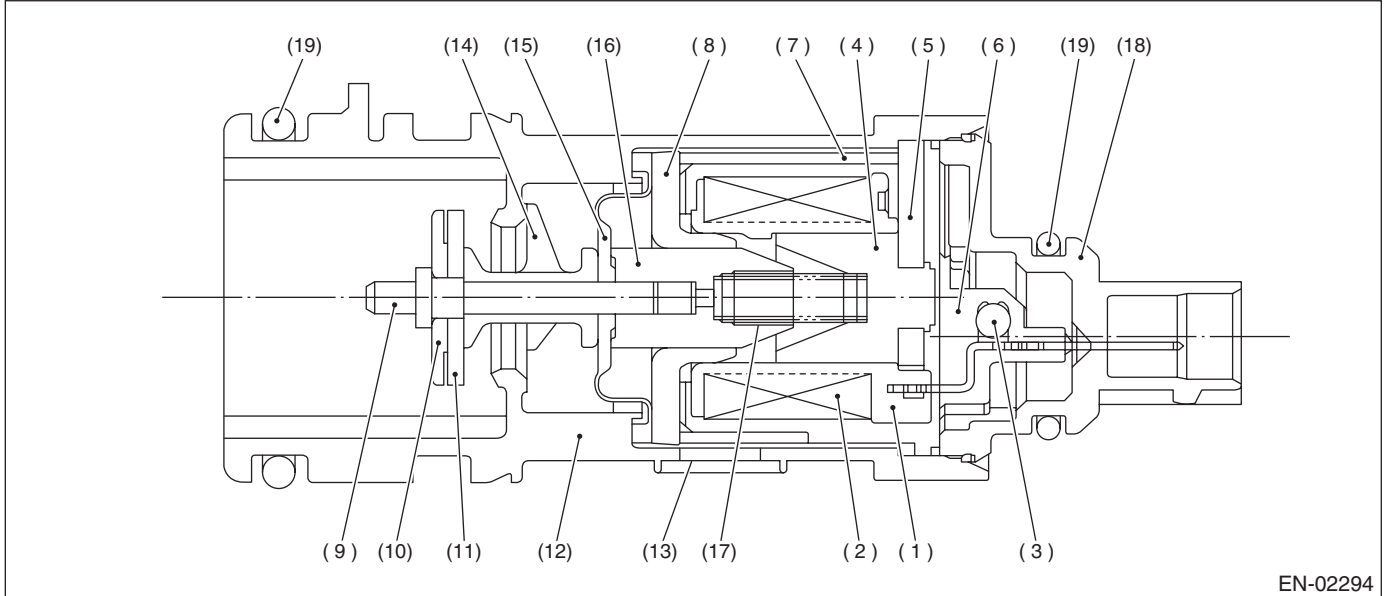

- |                 |                    |                   |
|-----------------|--------------------|-------------------|
| (1) Bobbin      | (8) Magnetic plate | (14) Retainer     |
| (2) Coil        | (9) Shaft          | (15) Diaphragm    |
| (3) Diode       | (10) Plate         | (16) Movable core |
| (4) Stator core | (11) Valve         | (17) Spring       |
| (5) End plate   | (12) Housing       | (18) Cover        |
| (6) Body        | (13) Filter        | (19) O-ring       |
| (7) Yoke        |                    |                   |

#### 3. ENABLE CONDITION

Secondary Parameters	Enable Conditions
Drain valve	Open
Battery voltage	$\geq 10.9 \text{ V}$
Atmospheric pressure	$\geq 75.0 \text{ kPa}$ (563 mmHg, 22.2 inHg)
Tank pressure when starter is OFF → ON	$-0.67 \text{ — } 1.43 \text{ kPa}$ ( $-5 \text{ — } 10.7 \text{ mmHg}$ , $-0.20 \text{ — } 0.42 \text{ inHg}$ )

#### 4. GENERAL DRIVING CYCLE

Always perform the diagnosis continuously.



# Diagnostic Trouble Code (DTC) Detecting Criteria

GENERAL DESCRIPTION

## 5. DIAGNOSTIC METHOD

### Abnormality Judgment

Judge as NG when the continuous time of meeting the malfunction criteria below becomes more than 3 seconds.

### Judgment Value

Malfunction Criteria	Threshold Value
Tank pressure	$\leq -4.0$ kPa ( $-30$ mmHg, $-1.18$ inHg)

**Time Needed for Diagnosis:** 3 seconds

**Malfunction Indicator Light Illumination:** Illuminates as soon as a malfunction occurs.

### Normality Judgment

Judge as OK and clear the NG when all the malfunction criteria below are met.

### Judgment Value

Malfunction Criteria	Threshold Value
Tank pressure	$> -4.0$ kPa ( $-30$ mmHg, $-1.18$ inHg)
Cumulative time when all of the malfunction criteria below is completed.	$\geq 30$ sec.
Purge control solenoid valve duty ratio	Not = 0
Fuel temperature	$-10$ — $45^{\circ}\text{C}$ ( $14$ — $113^{\circ}\text{F}$ )
Intake manifold relative pressure	$\leq -26.7$ kPa ( $-200$ mmHg, $-7.87$ inHg)

## 6. DTC CLEAR CONDITION

- When the OK idling cycle is completed 40 times in a row
- When "Clear Memory" is performed

## 7. MALFUNCTION INDICATOR LIGHT CLEAR CONDITION

- When the OK driving cycle is completed 3 times in a row
- When "Clear Memory" is performed

## 8. FAIL SAFE

Pressure control solenoid valve control: Open the pressure control solenoid valve.

## 9. ECM OPERATION AT DTC SETTING

Memorize the freeze frame data. (For test mode \$02)

# Diagnostic Trouble Code (DTC) Detecting Criteria

## GENERAL DESCRIPTION

### DB:DTC P1491 POSITIVE CRANKCASE VENTILATION (BLOW-BY) FUNCTION PROBLEM

#### 1. OUTLINE OF DIAGNOSIS

Detect the blow-by hose release abnormality.

Judge as NG when the diagnosis terminal voltage is high.

#### 2. COMPONENT DESCRIPTION

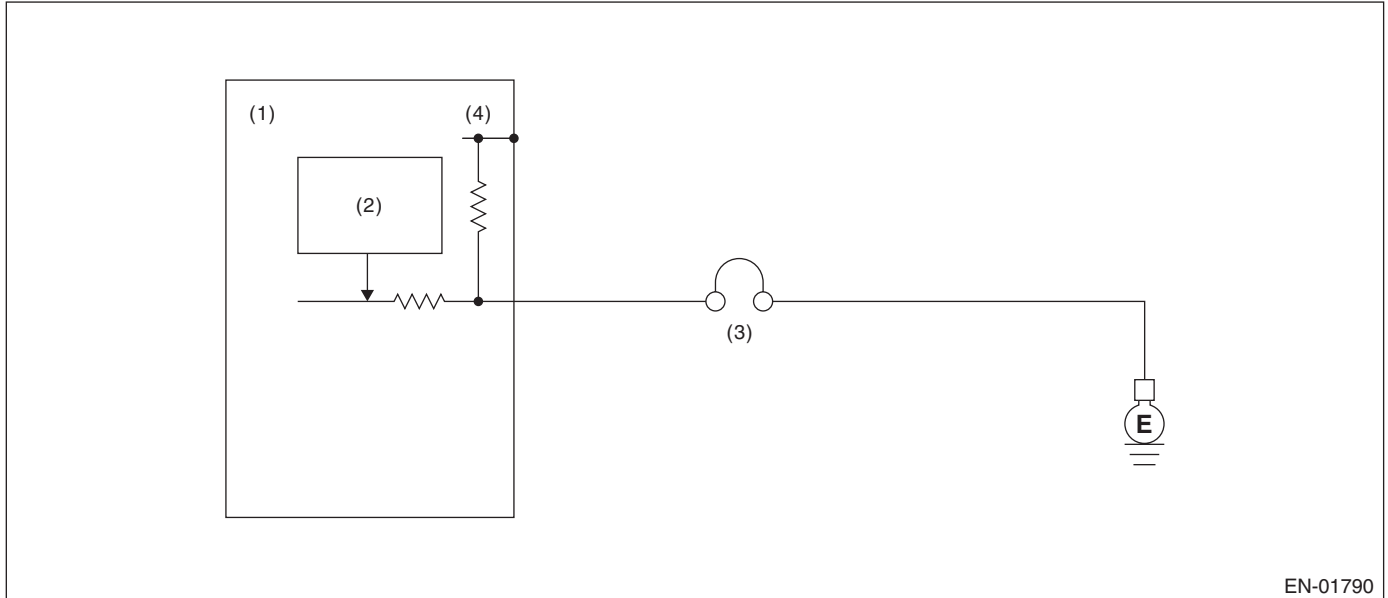

- (1) Engine control module (ECM)
- (2) Detecting circuit
- (3) PCV diagnosis connector
- (4) 5 V

#### 3. ENABLE CONDITION

Secondary Parameters	Enable Conditions
None	

#### 4. GENERAL DRIVING CYCLE

Always perform the diagnosis continuously.

# Diagnostic Trouble Code (DTC) Detecting Criteria

GENERAL DESCRIPTION

## 5. DIAGNOSTIC METHOD

### Abnormality Judgment

Judge as NG when the continuous time of meeting the malfunction criteria below becomes more than 2.5 seconds.

### Judgment Value

Malfunction Criteria	Threshold Value
Battery voltage	> 10.9 V
Positive crankcase ventilation diagnosis voltage	High
Engine speed	≥ 500 rpm

**Time Needed for Diagnosis:** 2.5 seconds

**Malfunction Indicator Light Illumination:** Illuminates as soon as a malfunction occurs.

### Normality Judgment

Judge as OK and clear the NG when the malfunction criteria below are met.

### Judgment Value

Malfunction Criteria	Threshold Value
Battery voltage	> 10.9 V
Positive crankcase ventilation diagnosis voltage	Low
Engine speed	≥ 500 rpm

## 6. DTC CLEAR CONDITION

- When the OK idling cycle is completed 40 times in a row
- When "Clear Memory" is performed

## 7. MALFUNCTION INDICATOR LIGHT CLEAR CONDITION

- When the OK driving cycle is completed 3 times in a row
- When "Clear Memory" is performed

## 8. FAIL SAFE

None

## 9. ECM OPERATION AT DTC SETTING

Memorize the diagnostic value and trouble standard value. (For test mode \$06)

# Diagnostic Trouble Code (DTC) Detecting Criteria

## GENERAL DESCRIPTION

---

### DC:DTC P1518 STARTER SWITCH CIRCUIT LOW INPUT

#### 1. OUTLINE OF DIAGNOSIS

Detect the open or short circuit of starter SW.

Judge as OFF NG when the engine starts without starter ON experience.

#### 2. ENABLE CONDITION

Secondary Parameters	Enable Conditions
None	

#### 3. GENERAL DRIVING CYCLE

Always perform the diagnosis continuously.

#### 4. DIAGNOSTIC METHOD

##### Abnormality Judgment

Judge as OFF NG when the following conditions are established.

##### Judgment Value

Malfunction Criteria	Threshold Value
Vehicle speed	< 1 km/h (0.62 MPH)
Starter ON signal	Not detected
Engine speed in 0.8 seconds or more for which the condition that engine speed is less than 500 rpm continues	≥ 500 rpm

**Time Needed for Diagnosis:** 1 second

**Malfunction Indicator Light Illumination:** Illuminates when malfunction occurs in 2 continuous driving cycles.

##### Normality Judgment

Judge as OFF OK and clear the NG when the malfunction criteria below are met.

##### Judgment Value

Malfunction Criteria	Threshold Value
Starter ON	Experienced
Starter ON diagnosis	Not diagnosed
Battery voltage	> 8 V

#### 5. DTC CLEAR CONDITION

- When the OK idling cycle is completed 40 times in a row
- When "Clear Memory" is performed

#### 6. MALFUNCTION INDICATOR LIGHT CLEAR CONDITION

- When the OK driving cycle is completed 3 times in a row
- When "Clear Memory" is performed

#### 7. FAIL SAFE

None

#### 8. ECM OPERATION AT DTC SETTING

Memorize the freeze frame data. (For test mode \$02)

## DD:DTC P1560 BACK-UP VOLTAGE CIRCUIT MALFUNCTION

### 1. OUTLINE OF DIAGNOSIS

Detect the open/short circuit of back-up power supply circuit.

Judge as NG when the backup voltage becomes smaller than the battery voltage.

### 2. ENABLE CONDITION

Secondary Parameters	Enable Conditions
None	

### 3. GENERAL DRIVING CYCLE

Always perform the diagnosis continuously.

### 4. DIAGNOSTIC METHOD

#### Abnormality Judgment

Judge as NG when the continuous time of meeting the malfunction criteria below becomes more than 2.5 seconds.

#### Judgment Value

Malfunction Criteria	Threshold Value
Voltage of back-up power supply	< Battery voltage × 0.7
Battery voltage	≥ 10.9 V

**Time Needed for Diagnosis:** 2.5 seconds

**Malfunction Indicator Light Illumination:** Illuminates as soon as a malfunction occurs.

#### Normality Judgment

Judge as OK and clear the NG when the malfunction criteria below are met.

#### Judgment Value

Malfunction Criteria	Threshold Value
Voltage of back-up power supply	≥ Battery voltage × 0.7
Battery voltage	≥ 10.9 V

### 5. DTC CLEAR CONDITION

- When the OK idling cycle is completed 40 times in a row
- When "Clear Memory" is performed

### 6. MALFUNCTION INDICATOR LIGHT CLEAR CONDITION

- When the OK driving cycle is completed 3 times in a row
- When "Clear Memory" is performed

### 7. FAIL SAFE

None

### 8. ECM OPERATION AT DTC SETTING

Memorize the freeze frame data. (For test mode \$02)

## Diagnostic Trouble Code (DTC) Detecting Criteria

### GENERAL DESCRIPTION

---

#### **DE:DTC P1570 ANTENNA**

NOTE:

For the detection standard, refer to DTC P0513 "INCORRECT IMMOBILIZER KEY". <Ref. to GD(H4DOTC)-179, DTC P0513 INCORRECT IMMOBILIZER KEY, Diagnostic Trouble Code (DTC) Detecting Criteria.>

#### **DF:DTC P1571 REFERENCE CODE INCOMPATIBILITY**

NOTE:

For the detection standard, refer to DTC P0513 "INCORRECT IMMOBILIZER KEY". <Ref. to GD(H4DOTC)-179, DTC P0513 INCORRECT IMMOBILIZER KEY, Diagnostic Trouble Code (DTC) Detecting Criteria.>

#### **DG:DTC P1572 IMM CIRCUIT FAILURE (EXCEPT ANTENNA CIRCUIT)**

NOTE:

For the detection standard, refer to DTC P0513 "INCORRECT IMMOBILIZER KEY". <Ref. to GD(H4DOTC)-179, DTC P0513 INCORRECT IMMOBILIZER KEY, Diagnostic Trouble Code (DTC) Detecting Criteria.>

#### **DH:DTC P1574 KEY COMMUNICATION FAILURE**

NOTE:

For the detection standard, refer to DTC P0513 "INCORRECT IMMOBILIZER KEY". <Ref. to GD(H4DOTC)-179, DTC P0513 INCORRECT IMMOBILIZER KEY, Diagnostic Trouble Code (DTC) Detecting Criteria.>

#### **DI: DTC P1576 EGI CONTROL MODULE EEPROM**

NOTE:

For the detection standard, refer to DTC P0513 "INCORRECT IMMOBILIZER KEY". <Ref. to GD(H4DOTC)-179, DTC P0513 INCORRECT IMMOBILIZER KEY, Diagnostic Trouble Code (DTC) Detecting Criteria.>

#### **DJ:DTC P1577 IMM CONTROL MODULE EEPROM**

NOTE:

For the detection standard, refer to DTC P0513 "INCORRECT IMMOBILIZER KEY". <Ref. to GD(H4DOTC)-179, DTC P0513 INCORRECT IMMOBILIZER KEY, Diagnostic Trouble Code (DTC) Detecting Criteria.>

## DK:DTC P1602 CONTROL MODULE PROGRAMMING ERROR

### 1. OUTLINE OF DIAGNOSIS

Detect the malfunction of catalytic converter initial warm-up retard angle control.

Judge as NG if the ECM is not operating properly when performing catalytic converter initial warm-up retard angle control.

Judge as NG when either the exhaust temperature diagnosis or the idle speed diagnosis becomes NG.

- Exhaust temperature diagnosis

Judge as NG if the exhaust temperature is below the specified value at 14 seconds after a cold start.

- Idle speed diagnosis

Judge as NG when actual engine speed is not close to the target engine speed after stopping the retard angle control.

### 2. ENABLE CONDITION

Secondary Parameters	Enable Conditions
Atmospheric pressure	> 75.1 kPa (563 mmHg, 22.2 inHg)
Battery voltage	> 10.9 V
Cold start diagnosis	Incomplete
Engine	Run
Vehicle speed	≤ 2 km/h (1 MPH)
Misfire in 200 engine revs.	< 5
Time elapsed after engine start	14 seconds

### 3. GENERAL DRIVING CYCLE

Perform diagnosis during cold start.

# Diagnostic Trouble Code (DTC) Detecting Criteria

## GENERAL DESCRIPTION

---

### 4. DIAGNOSTIC METHOD

- Exhaust temperature diagnosis

#### Abnormality Judgment

When the diagnostic execution conditions are established, calculate the estimated exhaust temperature. Judge as NG if the following conditions are established within 14 seconds after starting the engine.

#### Judgment Value

Malfunction Criteria	Threshold Value
Estimated exhaust temperature	< Value from Map 1

#### Map 1

Coolant temperature at engine start	- 40°C (-40°F)	- 30°C (-22°F)	- 20°C (-4°F)	- 10°C (14°F)	0°C (32°F)	10°C (50°F)	20°C (68°F)	30°C (86°F)	40°C (104°F)	50°C (122°F)
Threshold Value	200°C (392°F)	200°C (392°F)	200°C (392°F)	200°C (392°F)	200°C (392°F)	200°C (392°F)	180°C (356°F)	180°C (356°F)	180°C (356°F)	180°C (356°F)

**Time Needed for Diagnosis:** 14 seconds

**Malfunction Indicator Light Illumination:** Illuminates when malfunction occurs in 2 continuous driving cycles.

#### Normality Judgment

Judge as OK when the following conditions are established after predetermined amount of time has passed.

#### Judgment Value

Malfunction Criteria	Threshold Value
Estimated exhaust temperature	≥ Value from Map 1

- Idle speed diagnosis

Judge as NG when all the following conditions are established and judge as OK when not met.

Malfunction Criteria	Threshold Value
Continuous time of (target engine RPM – engine RPM > 100)	≥ 10000 milliseconds
(actual retard amount > 5°C/A)	≥ 3000 milliseconds

**Time Needed for Diagnosis:** 6 seconds

**Malfunction Indicator Light Illumination:** Illuminates when malfunction occurs in 2 continuous driving cycles.

### 5. DTC CLEAR CONDITION

- When the OK idling cycle is completed 40 times in a row
- When “Clear Memory” is performed

### 6. MALFUNCTION INDICATOR LIGHT CLEAR CONDITION

- When the OK driving cycle is completed 3 times in a row
- When “Clear Memory” is performed

### 7. FAIL SAFE

None

### 8. ECM OPERATION AT DTC SETTING

Memorize the freeze frame data. (For test mode \$02)



# Diagnostic Trouble Code (DTC) Detecting Criteria

GENERAL DESCRIPTION

## DL:DTC P2004 INTAKE MANIFOLD RUNNER CONTROL STUCK OPEN (BANK 1)

### 1. OUTLINE OF DIAGNOSIS

Detect the malfunction of tumble generator valve motor function.

Judge open fixing malfunction when the opening degree is large even after finishing the tumble generator valve closing driving.

### 2. ENABLE CONDITION

Secondary Parameters	Enable Conditions
Battery voltage	$\geq 10.9 \text{ V}$
Engine coolant temperature	$\geq 0^\circ\text{C}$ (32°F)
Ambient air temperature	$\geq 0^\circ\text{C}$ (32°F)

### 3. GENERAL DRIVING CYCLE

Always perform the diagnosis continuously.

### 4. DIAGNOSTIC METHOD

#### Abnormality Judgment

Judge as NG when the continuous time of meeting the malfunction criteria below becomes more than 3 seconds.

#### Judgment Value

Malfunction Criteria	Threshold Value
Tumble generator valve opening	$\geq 67.4^\circ$
Tumble generator valve "close" signal output	2.2 seconds or more

**Time Needed for Diagnosis:** 3 seconds

**Malfunction Indicator Light Illumination:** Illuminates as soon as a malfunction occurs.

#### Normality Judgment

Judge as OK and clear the NG when the malfunction criteria below are met.

#### Judgment Value

Malfunction Criteria	Threshold Value
Tumble generator valve opening	$< 67.4^\circ$
Tumble generator valve "close" signal output	2.2 seconds or more

### 5. DTC CLEAR CONDITION

- When the OK idling cycle is completed 40 times in a row
- When "Clear Memory" is performed

### 6. MALFUNCTION INDICATOR LIGHT CLEAR CONDITION

- When the OK driving cycle is completed 3 times in a row
- When "Clear Memory" is performed

### 7. FAIL SAFE

Tumble generator valve opening

- For tumble generator valve all closing points learning, not allowed to update to closing side.
- For tumble generator valve all opening points learning, not allowed to update to opening side.

Tumble generator valve control

- Output the open signal.

### 8. ECM OPERATION AT DTC SETTING

Memorize the freeze frame data. (For test mode \$02)

# Diagnostic Trouble Code (DTC) Detecting Criteria

## GENERAL DESCRIPTION

### DM:DTC P2005 INTAKE MANIFOLD RUNNER CONTROL STUCK OPEN (BANK 2)

#### 1. OUTLINE OF DIAGNOSIS

Detect the malfunction of tumble generator valve motor function.

Judge open fixing malfunction when the opening degree is large even after finishing the tumble generator valve closing driving.

#### 2. ENABLE CONDITION

Secondary Parameters	Enable Conditions
Battery voltage	$\geq 10.9 \text{ V}$
Engine coolant temperature	$\geq 0^\circ\text{C}$ (32°F)
Ambient air temperature	$\geq 0^\circ\text{C}$ (32°F)

#### 3. GENERAL DRIVING CYCLE

Always perform the diagnosis continuously.

#### 4. DIAGNOSTIC METHOD

##### Abnormality Judgment

Judge as NG when the continuous time of meeting the malfunction criteria below becomes more than 3 seconds.

##### Judgment Value

Malfunction Criteria	Threshold Value
Tumble generator valve opening	$\geq 67.4^\circ$
Tumble generator valve "close" signal output	2.2 seconds or more

**Time Needed for Diagnosis:** 3 seconds

**Malfunction Indicator Light Illumination:** Illuminates as soon as a malfunction occurs.

##### Normality Judgment

Judge as OK and clear the NG when the malfunction criteria below are met.

##### Judgment Value

Malfunction Criteria	Threshold Value
Tumble generator valve opening	$< 67.4^\circ$
Tumble generator valve "close" signal output	2.2 seconds or more

#### 5. DTC CLEAR CONDITION

- When the OK idling cycle is completed 40 times in a row
- When "Clear Memory" is performed

#### 6. MALFUNCTION INDICATOR LIGHT CLEAR CONDITION

- When the OK driving cycle is completed 3 times in a row
- When "Clear Memory" is performed

#### 7. FAIL SAFE

Tumble generator valve opening

- For tumble generator valve all closing points learning, not allowed to update to closing side.
- For tumble generator valve all opening points learning, not allowed to update to opening side.

Tumble generator valve control

- Output the open signal.

#### 8. ECM OPERATION AT DTC SETTING

Memorize the freeze frame data. (For test mode \$02)

# Diagnostic Trouble Code (DTC) Detecting Criteria

GENERAL DESCRIPTION

## DN:DTC P2006 INTAKE MANIFOLD RUNNER CONTROL STUCK CLOSED (BANK 1)

### 1. OUTLINE OF DIAGNOSIS

Detect the malfunction of tumble generator valve motor function.

Judge close fixing malfunction when the opening degree is small even after finishing the tumble generator valve open driving.

### 2. ENABLE CONDITION

Secondary Parameters	Enable Conditions
Battery voltage	$\geq 10.9$ V
Engine coolant temperature	$\geq 0^{\circ}\text{C}$ (32°F)
Ambient air temperature	$\geq 0^{\circ}\text{C}$ (32°F)

### 3. GENERAL DRIVING CYCLE

Always perform the diagnosis continuously.

### 4. DIAGNOSTIC METHOD

#### Abnormality Judgment

Judge as NG when the continuous time of meeting the malfunction criteria below becomes more than 3 seconds.

#### Judgment Value

Malfunction Criteria	Threshold Value
Tumble generator valve opening	$< 67.4^{\circ}$
Tumble generator valve "open" signal output	2.2 seconds or more

**Time Needed for Diagnosis:** 3 seconds

**Malfunction Indicator Light Illumination:** Illuminates as soon as a malfunction occurs.

#### Normality Judgment

Judge as OK and clear the NG when the malfunction criteria below are met.

#### Judgment Value

Malfunction Criteria	Threshold Value
Tumble generator valve opening	$\geq 67.4^{\circ}$
Tumble generator valve "open" signal output	2.2 seconds or more

### 5. DTC CLEAR CONDITION

- When the OK idling cycle is completed 40 times in a row
- When "Clear Memory" is performed

### 6. MALFUNCTION INDICATOR LIGHT CLEAR CONDITION

- When the OK driving cycle is completed 3 times in a row
- When "Clear Memory" is performed

### 7. FAIL SAFE

Tumble generator valve opening

- For tumble generator valve all closing points learning, not allowed to update to closing side.
- For tumble generator valve all opening points learning, not allowed to update to opening side.

Tumble generator valve control

- Output the close signal.

### 8. ECM OPERATION AT DTC SETTING

Memorize the freeze frame data. (For test mode \$02)

# Diagnostic Trouble Code (DTC) Detecting Criteria

## GENERAL DESCRIPTION

---

### DO:DTC P2007 INTAKE MANIFOLD RUNNER CONTROL STUCK CLOSED (BANK 2)

#### 1. OUTLINE OF DIAGNOSIS

Detect the malfunction of tumble generator valve motor function.

Judge close fixing malfunction when the opening degree is small even after finishing the tumble generator valve open driving.

#### 2. ENABLE CONDITION

Secondary Parameters	Enable Conditions
Battery voltage	$\geq 10.9$ V
Engine coolant temperature	$\geq 0^{\circ}\text{C}$ (32°F)
Ambient air temperature	$\geq 0^{\circ}\text{C}$

#### 3. GENERAL DRIVING CYCLE

Always perform the diagnosis continuously.

#### 4. DIAGNOSTIC METHOD

##### Abnormality Judgment

Judge as NG when the continuous time of meeting the malfunction criteria below becomes more than 3 seconds.

##### Judgment Value

Malfunction Criteria	Threshold Value
Tumble generator valve opening	$< 67.4^{\circ}$
Tumble generator valve "open" signal output	2.2 seconds or more

**Time Needed for Diagnosis:** 3 seconds

**Malfunction Indicator Light Illumination:** Illuminates as soon as a malfunction occurs.

##### Normality Judgment

Judge as OK and clear the NG when the malfunction criteria below are met.

##### Judgment Value

Malfunction Criteria	Threshold Value
Tumble generator valve opening	$\geq 67.4^{\circ}$
Tumble generator valve "open" signal output	2.2 seconds or more

#### 5. DTC CLEAR CONDITION

- When the OK idling cycle is completed 40 times in a row
- When "Clear Memory" is performed

#### 6. MALFUNCTION INDICATOR LIGHT CLEAR CONDITION

- When the OK driving cycle is completed 3 times in a row
- When "Clear Memory" is performed

#### 7. FAIL SAFE

Tumble generator valve opening

- For tumble generator valve all closing points learning, not allowed to update to closing side.
- For tumble generator valve all opening points learning, not allowed to update to opening side.

Tumble generator valve control

- Output the close signal.

#### 8. ECM OPERATION AT DTC SETTING

Memorize the freeze frame data. (For test mode \$02)

## DP:DTC P2008 INTAKE MANIFOLD RUNNER CONTROL CIRCUIT / OPEN (BANK 1)

### 1. OUTLINE OF DIAGNOSIS

Detect the open or short circuit of tumble generator valve motor.

Judge NG when the open signal is sent from IC after tumble generator valve driving IC diagnosis.

### 2. COMPONENT DESCRIPTION

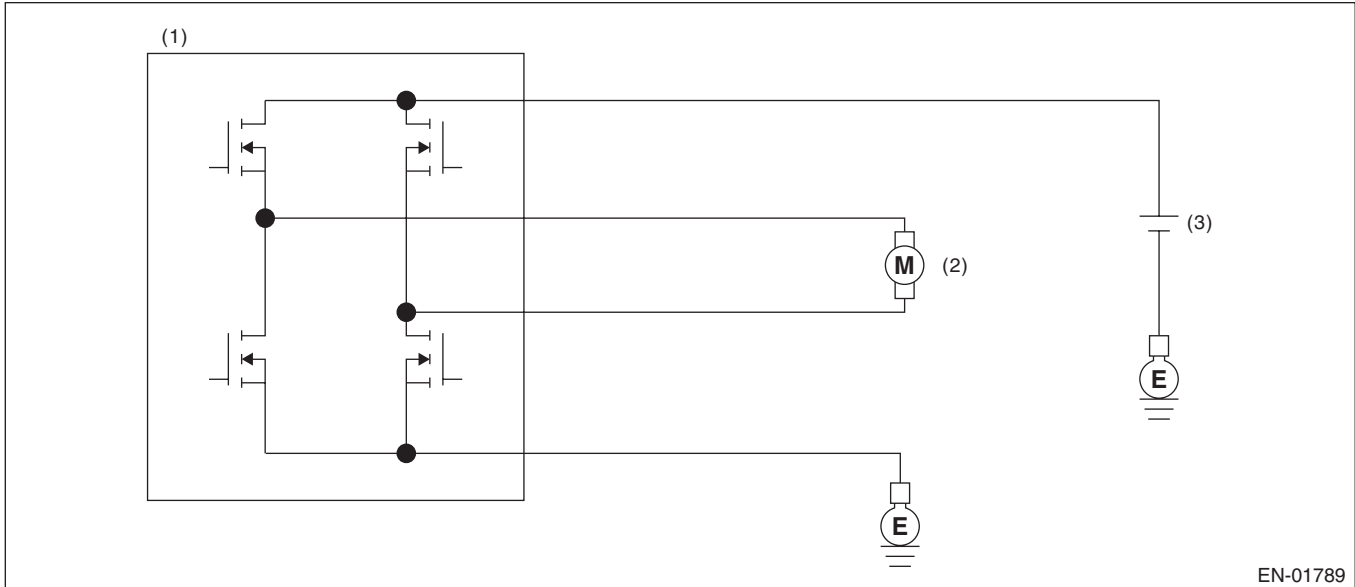

- (1) Engine control module (ECM)
- (2) Tumble generator valve
- (3) Battery

### 3. ENABLE CONDITION

Secondary Parameters	Enable Conditions
Battery voltage	$\geq 10.9 \text{ V}$
ECM output signal	Before signal change from ON $\rightarrow$ OFF
Tumble generator valve ON signal output time	20 milliseconds or more

### 4. GENERAL DRIVING CYCLE

Always perform the diagnosis continuously.

### 5. DIAGNOSTIC METHOD

At the main IC, check the sent signal at each timing which occurs just before the tumble generator valve output is set to ON  $\rightarrow$  OFF, and judge open NG when the open NG signal is sent 1 second in a row.

Judge OK and clear the NG when the OK signal is sent.

#### Judgment Value

Malfunction Criteria	Threshold Value
Open NG signal input	Low
Overcurrent NG signal input	High

**Time Needed for Diagnosis:** 10 seconds

**Malfunction Indicator Light Illumination:** Illuminates as soon as a malfunction occurs.

# Diagnostic Trouble Code (DTC) Detecting Criteria

## GENERAL DESCRIPTION

---

### 6. DTC CLEAR CONDITION

- When the OK idling cycle is completed 40 times in a row
- When "Clear Memory" is performed

### 7. MALFUNCTION INDICATOR LIGHT CLEAR CONDITION

- When the OK driving cycle is completed 3 times in a row
- When "Clear Memory" is performed

### 8. FAIL SAFE

Tumble generator valve control: Not allowed to move tumble generator valve.

### 9. ECM OPERATION AT DTC SETTING

Memorize the freeze frame data. (For test mode \$02)

## DQ:DTC P2009 INTAKE MANIFOLD RUNNER CONTROL CIRCUIT LOW (BANK 1)

### 1. OUTLINE OF DIAGNOSIS

Detect the open or short circuit of tumble generator valve motor.

Judge NG when the overcurrent signal is sent from IC after tumble generator valve driving IC diagnosis.

### 2. COMPONENT DESCRIPTION

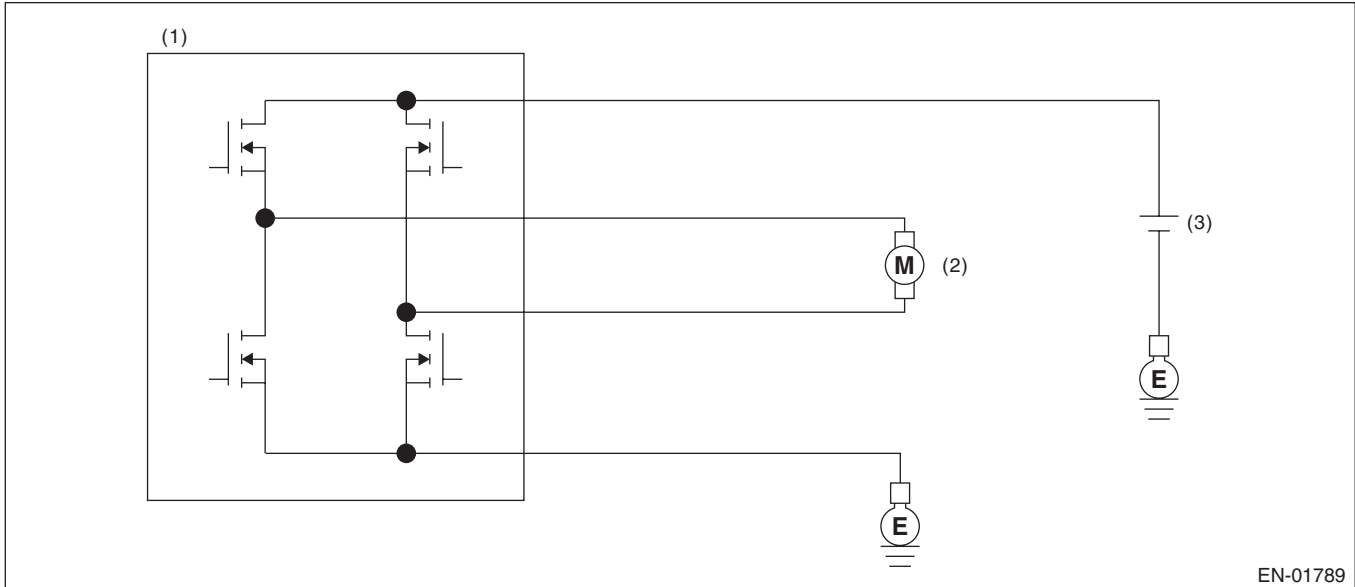

- (1) Engine control module (ECM)
- (2) Tumble generator valve
- (3) Battery

### 3. ENABLE CONDITION

Secondary Parameters	Enable Conditions
Battery voltage	≥ 10.9 V
ECM output signal	Before signal change from ON → OFF
Tumble generator valve ON signal output time	20 milliseconds or more

### 4. GENERAL DRIVING CYCLE

Always perform the diagnosis continuously.

# Diagnostic Trouble Code (DTC) Detecting Criteria

## GENERAL DESCRIPTION

---

### 5. DIAGNOSTIC METHOD

At the main IC, check the sent signal at each timing which occurs just before the tumble generator valve output is set to ON → OFF, and judge overcurrent NG when the overcurrent NG signal is sent 1 second in a row. Judge OK and clear the NG when the OK signal is sent.

#### Judgment Value

Malfunction Criteria	Threshold Value
Open NG signal input	High
Overcurrent NG signal input	Low

**Time Needed for Diagnosis:** 10 seconds

**Malfunction Indicator Light Illumination:** Illuminates as soon as a malfunction occurs.

### 6. DTC CLEAR CONDITION

- When the OK idling cycle is completed 40 times in a row
- When “Clear Memory” is performed

### 7. MALFUNCTION INDICATOR LIGHT CLEAR CONDITION

- When the OK driving cycle is completed 3 times in a row
- When “Clear Memory” is performed

### 8. FAIL SAFE

Tumble generator valve control: Not allowed to move tumble generator valve.

### 9. ECM OPERATION AT DTC SETTING

Memorize the freeze frame data. (For test mode \$02)



## DR:DTC P2011 INTAKE MANIFOLD RUNNER CONTROL CIRCUIT / OPEN (BANK 2)

### 1. OUTLINE OF DIAGNOSIS

Detect the open or short circuit of tumble generator valve motor.

Judge NG when the open signal is sent from IC after tumble generator valve driving IC diagnosis.

### 2. COMPONENT DESCRIPTION

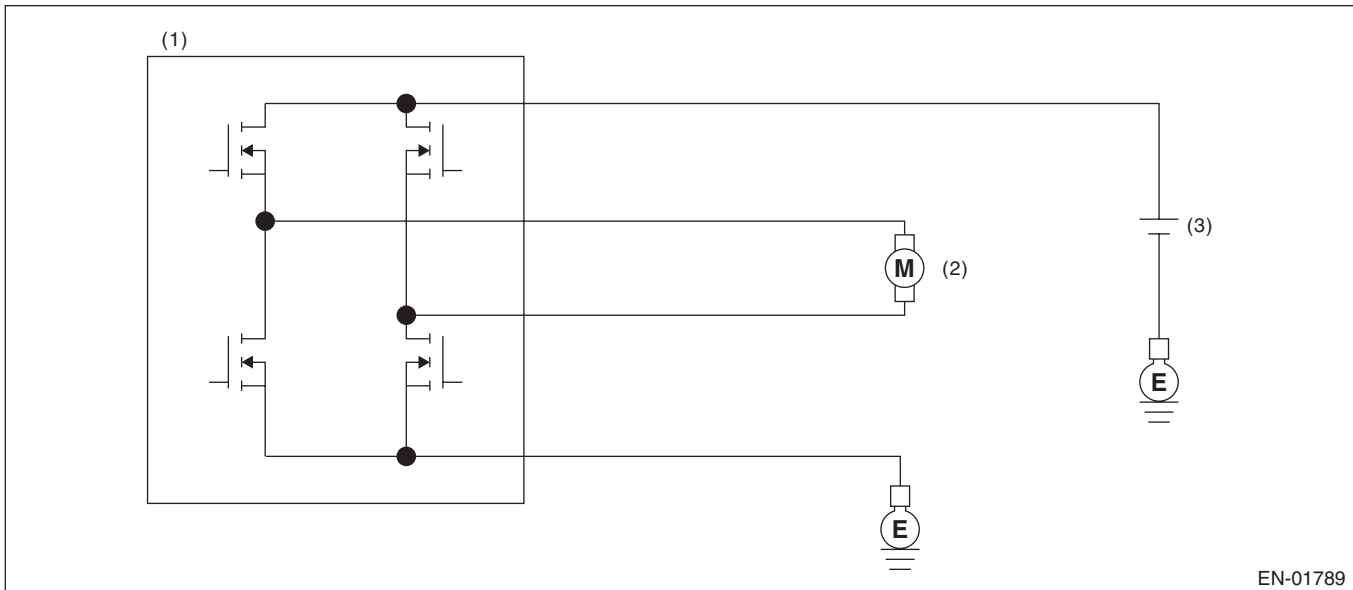

- (1) Engine control module (ECM)
- (2) Tumble generator valve
- (3) Battery

### 3. ENABLE CONDITION

Secondary Parameters	Enable Conditions
Battery voltage	$\geq 10.9 \text{ V}$
ECM output signal	Before signal change from ON $\rightarrow$ OFF
Tumble generator valve ON signal output time	20 milliseconds or more

### 4. GENERAL DRIVING CYCLE

Always perform the diagnosis continuously.

### 5. DIAGNOSTIC METHOD

At the main IC, check the sent signal at each timing which occurs just before the tumble generator valve output is set to ON  $\rightarrow$  OFF, and judge open NG when the open NG signal is sent 1 second in a row. Judge OK and clear the NG when the OK signal is sent.

#### Judgment Value

Malfunction Criteria	Threshold Value
Open NG signal input	Low
Overcurrent NG signal input	High

**Time Needed for Diagnosis:** 10 seconds

**Malfunction Indicator Light Illumination:** Illuminates as soon as a malfunction occurs.

# Diagnostic Trouble Code (DTC) Detecting Criteria

## GENERAL DESCRIPTION

---

### 6. DTC CLEAR CONDITION

- When the OK idling cycle is completed 40 times in a row
- When "Clear Memory" is performed

### 7. MALFUNCTION INDICATOR LIGHT CLEAR CONDITION

- When the OK driving cycle is completed 3 times in a row
- When "Clear Memory" is performed

### 8. FAIL SAFE

Tumble generator valve control: Not allowed to move tumble generator valve.

### 9. ECM OPERATION AT DTC SETTING

Memorize the freeze frame data. (For test mode \$02)

# Diagnostic Trouble Code (DTC) Detecting Criteria

GENERAL DESCRIPTION

## DS:DTC P2012 INTAKE MANIFOLD RUNNER CONTROL CIRCUIT LOW (BANK 2)

### 1. OUTLINE OF DIAGNOSIS

Detect the open or short circuit of tumble generator valve motor.

Judge NG when the overcurrent signal is sent from IC after tumble generator valve driving IC diagnosis.

### 2. COMPONENT DESCRIPTION

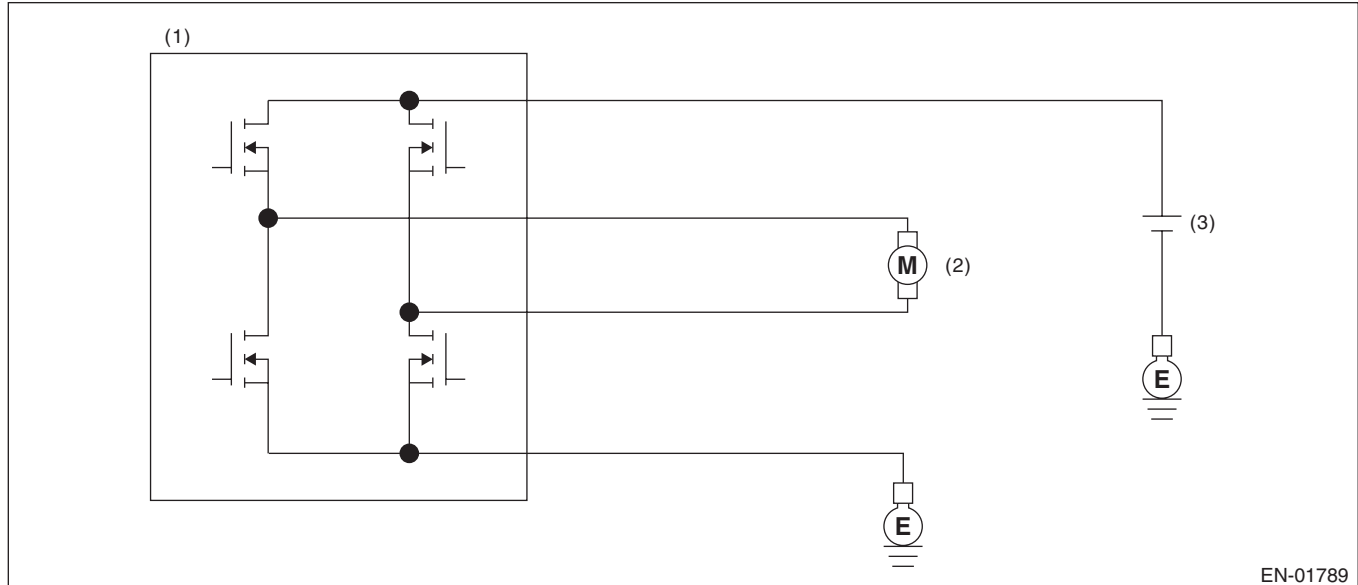

- (1) Engine control module (ECM)
- (2) Tumble generator valve
- (3) Battery

### 3. ENABLE CONDITION

Secondary Parameters	Enable Conditions
Battery voltage	$\geq 10.9$ V
ECM output signal	Before signal change from ON → OFF
Tumble generator valve ON signal output time	20 milliseconds or more

### 4. GENERAL DRIVING CYCLE

Always perform the diagnosis continuously.

### 5. DIAGNOSTIC METHOD

At the main IC, check the sent signal at each timing which occurs just before the tumble generator valve output is set to ON → OFF, and judge overcurrent NG when the overcurrent NG signal is sent 1 second in a row. Judge OK and clear the NG when the OK signal is sent.

#### Judgment Value

Malfunction Criteria	Threshold Value
Open NG signal input	High
Overcurrent NG signal input	Low

**Time Needed for Diagnosis:** 10 seconds

**Malfunction Indicator Light Illumination:** Illuminates as soon as a malfunction occurs.

# Diagnostic Trouble Code (DTC) Detecting Criteria

## GENERAL DESCRIPTION

---

### 6. DTC CLEAR CONDITION

- When the OK idling cycle is completed 40 times in a row
- When "Clear Memory" is performed

### 7. MALFUNCTION INDICATOR LIGHT CLEAR CONDITION

- When the OK driving cycle is completed 3 times in a row
- When "Clear Memory" is performed

### 8. FAIL SAFE

Tumble generator valve control: Not allowed to move tumble generator valve.

### 9. ECM OPERATION AT DTC SETTING

Memorize the freeze frame data. (For test mode \$02)

## DT:DTC P2016 INTAKE MANIFOLD RUNNER POSITION SENSOR / SWITCH CIRCUIT LOW (BANK 1)

### 1. OUTLINE OF DIAGNOSIS

Detect open or short circuit of tumble generator valve position sensor.

Judge as NG if it is out of specification.

### 2. COMPONENT DESCRIPTION

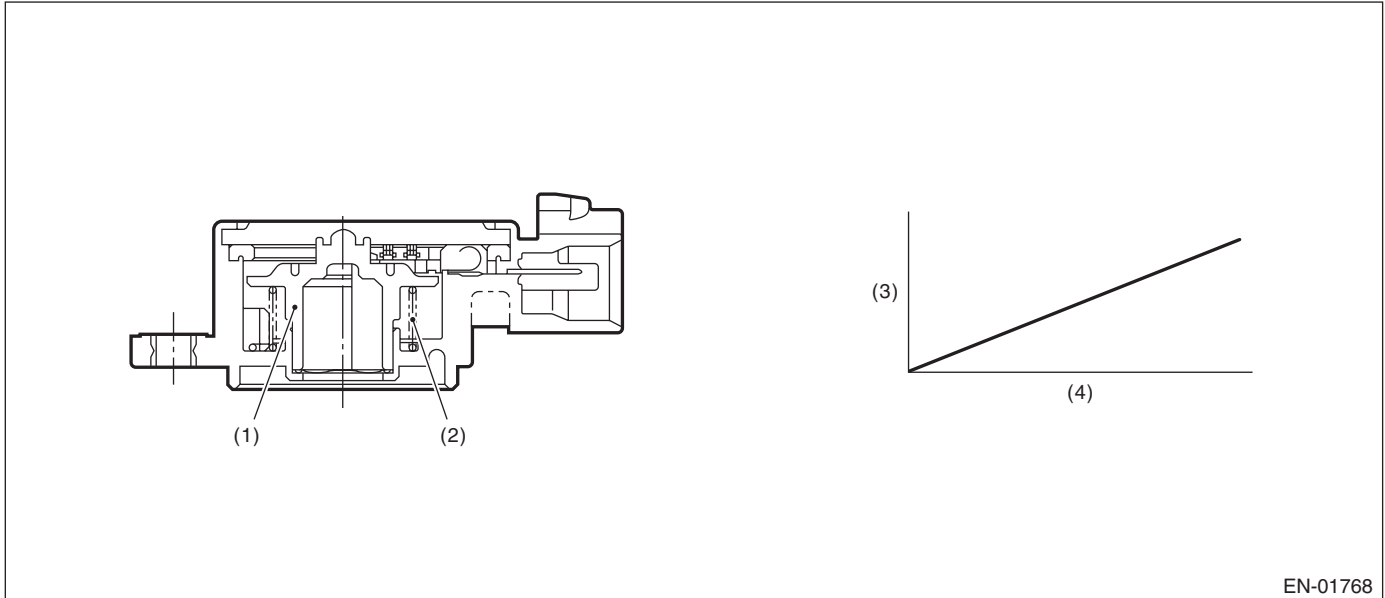

EN-01768

- (1) Rotor
- (2) Return spring
- (3) Voltage (V)
- (4) Tumble generator valve opening (°)

### 3. ENABLE CONDITION

Secondary Parameters	Enable Conditions
None	

### 4. GENERAL DRIVING CYCLE

Always perform the diagnosis continuously.

### 5. DIAGNOSTIC METHOD

Judge as NG when the continuous time of meeting the malfunction criteria below becomes 0.5 seconds or more. Judge as OK and clear the NG when the malfunction criteria below are not met.

#### Judgment Value

Malfunction Criteria	Threshold Value
Output voltage	< 0.167 V

**Time Needed for Diagnosis:** 0.5 seconds

**Malfunction Indicator Light Illumination:** Illuminates as soon as a malfunction occurs.

### 6. DTC CLEAR CONDITION

- When the OK idling cycle is completed 40 times in a row
- When "Clear Memory" is performed

# Diagnostic Trouble Code (DTC) Detecting Criteria

## GENERAL DESCRIPTION

---

### **7. MALFUNCTION INDICATOR LIGHT CLEAR CONDITION**

- When the OK driving cycle is completed 3 times in a row
- When “Clear Memory” is performed

### **8. FAIL SAFE**

Tumble generator valve opening

- For tumble generator valve all closing points learning, not allowed to update to closing side.
- For tumble generator valve all opening points learning, not allowed to update to opening side.

### **9. ECM OPERATION AT DTC SETTING**

Memorize the freeze frame data. (For test mode \$02)

## DU:DTC P2017 INTAKE MANIFOLD RUNNER POSITION SENSOR / SWITCH CIRCUIT HIGH (BANK 1)

### 1. OUTLINE OF DIAGNOSIS

Detect open or short circuit of tumble generator valve position sensor.

Judge as NG if it is out of specification.

### 2. COMPONENT DESCRIPTION

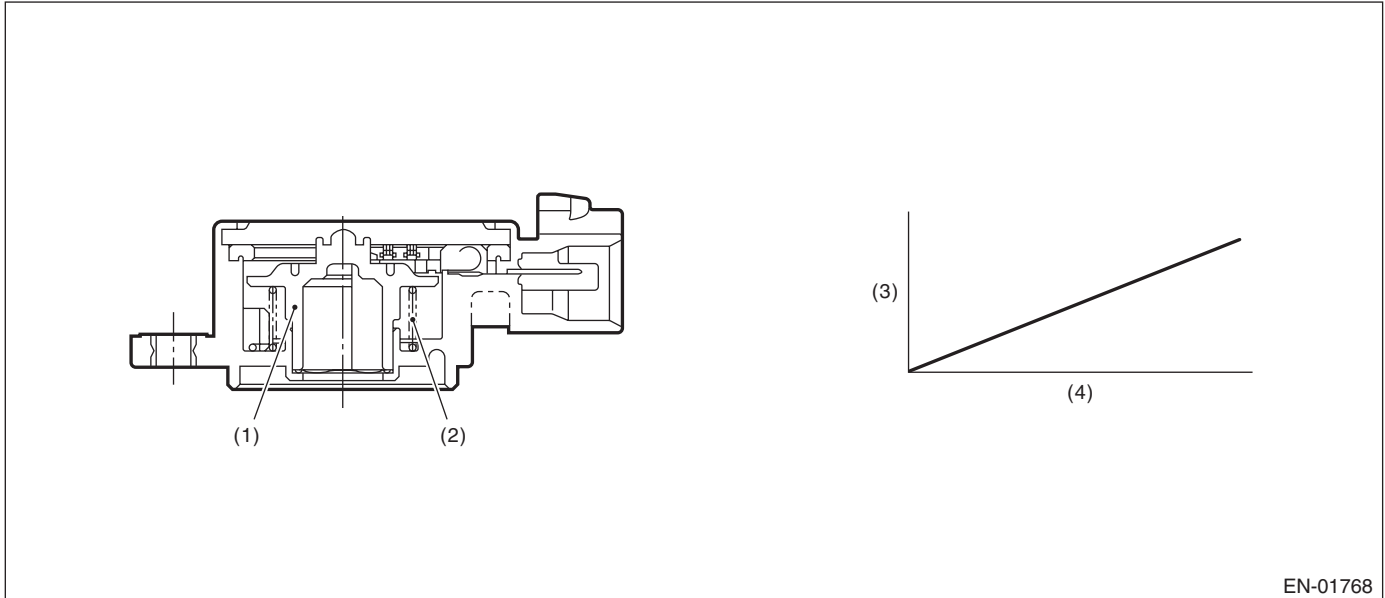

EN-01768

- (1) Rotor
- (2) Return spring
- (3) Voltage (V)
- (4) Throttle valve opening angle (°)

### 3. ENABLE CONDITION

Secondary Parameters	Enable Conditions
None	

### 4. GENERAL DRIVING CYCLE

Always perform the diagnosis continuously.

### 5. DIAGNOSTIC METHOD

Judge as NG when the continuous time of meeting the malfunction criteria below becomes 0.5 seconds or more. Judge as OK and clear the NG when the malfunction criteria below are not met.

#### Judgment Value

Malfunction Criteria	Threshold Value
Output voltage	≥ 4.843 V

**Time Needed for Diagnosis:** 0.5 seconds

**Malfunction Indicator Light Illumination:** Illuminates as soon as a malfunction occurs.

### 6. DTC CLEAR CONDITION

- When the OK idling cycle is completed 40 times in a row
- When "Clear Memory" is performed

# Diagnostic Trouble Code (DTC) Detecting Criteria

## GENERAL DESCRIPTION

---

### **7. MALFUNCTION INDICATOR LIGHT CLEAR CONDITION**

- When the OK driving cycle is completed 3 times in a row
- When “Clear Memory” is performed

### **8. FAIL SAFE**

Tumble generator valve opening

- For tumble generator valve all closing points learning, not allowed to update to closing side.
- For tumble generator valve all opening points learning, not allowed to update to opening side.

### **9. ECM OPERATION AT DTC SETTING**

Memorize the freeze frame data. (For test mode \$02)



## DV:DTC P2021 INTAKE MANIFOLD RUNNER POSITION SENSOR / SWITCH CIRCUIT LOW (BANK 2)

### 1. OUTLINE OF DIAGNOSIS

Detect open or short circuit of tumble generator valve position sensor.

Judge as NG if it is out of specification.

### 2. COMPONENT DESCRIPTION

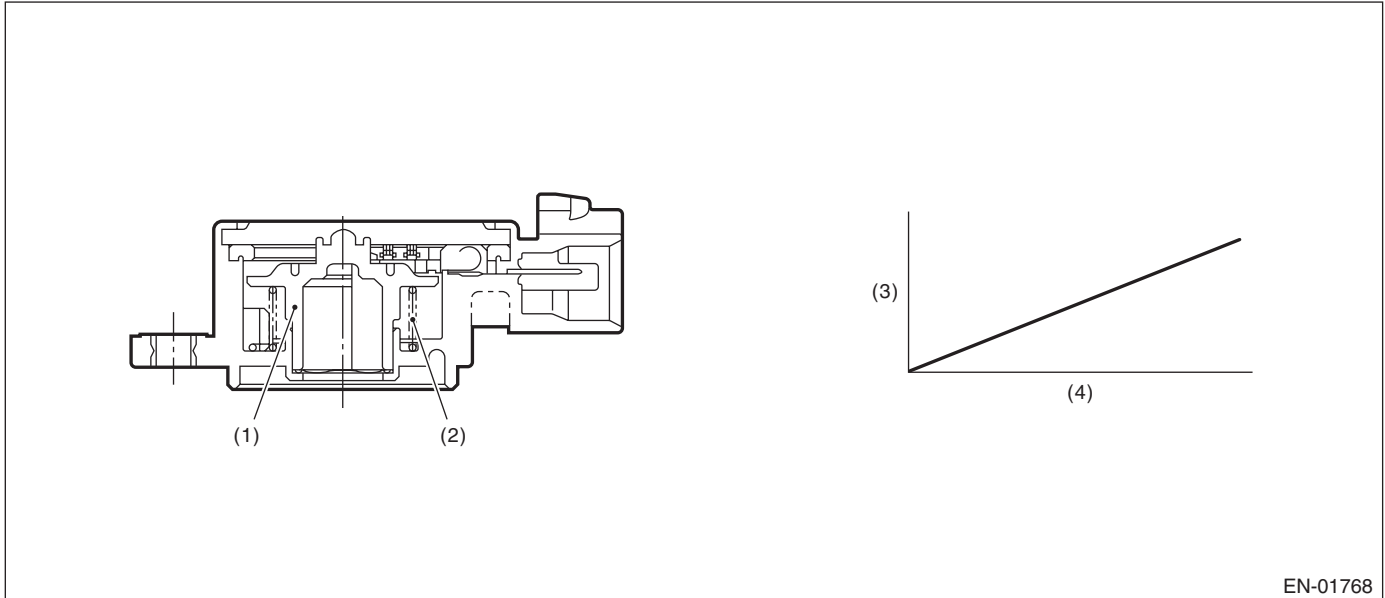

EN-01768

- (1) Rotor
- (2) Return spring
- (3) Voltage (V)
- (4) Tumble generator valve opening (°)

### 3. ENABLE CONDITION

Secondary Parameters	Enable Conditions
None	

### 4. GENERAL DRIVING CYCLE

Always perform the diagnosis continuously.

### 5. DIAGNOSTIC METHOD

Judge as NG when the continuous time of meeting the malfunction criteria below becomes 0.5 seconds or more. Judge as OK and clear the NG when the malfunction criteria below are not met.

#### Judgment Value

Malfunction Criteria	Threshold Value
Output voltage	< 0.167 V

**Time Needed for Diagnosis:** 0.5 seconds

**Malfunction Indicator Light Illumination:** Illuminates as soon as a malfunction occurs.

### 6. DTC CLEAR CONDITION

- When the OK idling cycle is completed 40 times in a row
- When "Clear Memory" is performed

# Diagnostic Trouble Code (DTC) Detecting Criteria

## GENERAL DESCRIPTION

---

### 7. MALFUNCTION INDICATOR LIGHT CLEAR CONDITION

- When the OK driving cycle is completed 3 times in a row
- When “Clear Memory” is performed

### 8. FAIL SAFE

Tumble generator valve opening

- For tumble generator valve all closing points learning, not allowed to update to closing side.
- For tumble generator valve all opening points learning, not allowed to update to opening side.

### 9. ECM OPERATION AT DTC SETTING

Memorize the freeze frame data. (For test mode \$02)

## DW:DTC P2022 INTAKE MANIFOLD RUNNER POSITION SENSOR / SWITCH CIRCUIT HIGH (BANK 2)

### 1. OUTLINE OF DIAGNOSIS

Detect open or short circuit of tumble generator valve position sensor.  
Judge as NG if it is out of specification.

### 2. COMPONENT DESCRIPTION

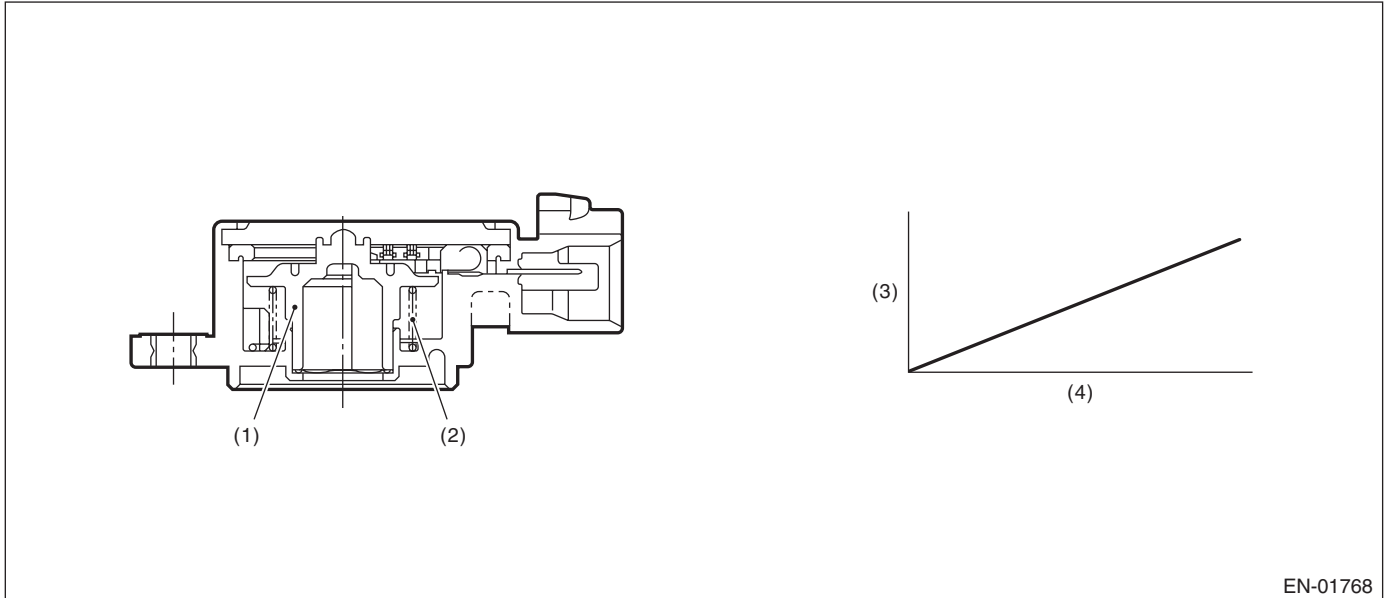

EN-01768

- (1) Rotor
- (2) Return spring
- (3) Voltage (V)
- (4) Tumble generator valve opening (°)

### 3. ENABLE CONDITION

Secondary Parameters	Enable Conditions
None	

### 4. GENERAL DRIVING CYCLE

Always perform the diagnosis continuously.

### 5. DIAGNOSTIC METHOD

Judge as NG when the continuous time of meeting the malfunction criteria below becomes 0.5 seconds or more. Judge as OK and clear the NG when the malfunction criteria below are not met.

#### Judgment Value

Malfunction Criteria	Threshold Value
Output voltage	≥ 4.843 V

**Time Needed for Diagnosis:** 0.5 seconds

**Malfunction Indicator Light Illumination:** Illuminates as soon as a malfunction occurs.

### 6. DTC CLEAR CONDITION

- When the OK idling cycle is completed 40 times in a row
- When "Clear Memory" is performed

# Diagnostic Trouble Code (DTC) Detecting Criteria

## GENERAL DESCRIPTION

---

### 7. MALFUNCTION INDICATOR LIGHT CLEAR CONDITION

- When the OK driving cycle is completed 3 times in a row
- When “Clear Memory” is performed

### 8. FAIL SAFE

Tumble generator valve opening

- For tumble generator valve all closing points learning, not allowed to update to closing side.
- For tumble generator valve all opening points learning, not allowed to update to opening side.

### 9. ECM OPERATION AT DTC SETTING

Memorize the freeze frame data. (For test mode \$02)

# Diagnostic Trouble Code (DTC) Detecting Criteria

GENERAL DESCRIPTION

## DX:DTC P2088 OCV SOLENOID VALVE SIGNAL A CIRCUIT OPEN (BANK 1)

### 1. OUTLINE OF DIAGNOSIS

Detect open or short circuit of the oil flow control valve solenoid.

Judge open NG when the current flow is small whereas duty signal is large, and judge short NG when the current flow is large whereas duty signal is small.

### 2. ENABLE CONDITION

Secondary Parameters	Enable Conditions
Battery voltage	$\geq 10.9$ V

### 3. GENERAL DRIVING CYCLE

Always perform the diagnosis continuously.

### 4. DIAGNOSTIC METHOD

#### Abnormality Judgment

Judge as NG when the continuous time of meeting the malfunction criteria below becomes 2 seconds or more.

#### Judgment Value

Malfunction Criteria	Threshold Value
Oil flow control solenoid valve control duty	$\geq 99.61\%$
Oil control solenoid valve control present current	$< 0.306$ A

**Time Needed for Diagnosis:** 2000 milliseconds

**Malfunction Indicator Light Illumination:** Illuminates as soon as a malfunction occurs.

#### Normality Judgment

Judge as OK and clear the NG when the continuous time with the following criteria established is more than 2 seconds.

#### Judgment Value

Malfunction Criteria	Threshold Value
Target current value of the oil flow control solenoid valve	$\geq 0.14\%$
Target current value of the oil flow control solenoid valve – Oil flow control solenoid valve control current value	$\geq 0.08$ A

### 5. DTC CLEAR CONDITION

- When the OK idling cycle is completed 40 times in a row
- When “Clear Memory” is performed

### 6. MALFUNCTION INDICATOR LIGHT CLEAR CONDITION

- When the OK driving cycle is completed 3 times in a row
- When “Clear Memory” is performed

# Diagnostic Trouble Code (DTC) Detecting Criteria

## GENERAL DESCRIPTION

---

### 7. FAIL SAFE

- Ignition timing whole learning compensation:
  - Enter the initial value (whole learning compensation factor = 0.5, Variable amount of whole learning compensation factor = 0.25) to the whole learning compensation factor and variable amount of whole learning compensation factor when IG OFF, and then make the whole learning incomplete.
  - Enter the initial value (whole learning compensation factor = 0.5, Variable amount of whole learning compensation factor = 0.25) to the whole learning compensation factor and variable amount of whole learning compensation factor when making a normality judgment → abnormality judgment, and then make the whole learning incomplete.
- Ignition timing partial learning compensation:
  - Enter the initial value (0°CA) to the compensation value of partial learning zone with IG OFF.
  - Enter the initial value (0°CA) to the compensation value of partial learning zone when making a normality judgment → abnormality judgment.
- AVCS control:
  - Maximum timing retard learning is not complete or maximum timing retard learning completion is not experienced.
  - ⇒ ISC feedback compensation: Do not perform the AVCS actual timing advance compensation.
  - Make the oil flow control solenoid valve drive duty a predetermined value (9.36%).

### 8. ECM OPERATION AT DTC SETTING

Memorize the freeze frame data. (For test mode \$02)

# Diagnostic Trouble Code (DTC) Detecting Criteria

GENERAL DESCRIPTION

## DY:DTC P2089 OCV SOLENOID VALVE SIGNAL A CIRCUIT SHORT (BANK 1)

### 1. OUTLINE OF DIAGNOSIS

Detect open or short circuit of the oil flow control valve solenoid.

Judge open NG when the current flow is small whereas duty signal is large, and judge short NG when the current flow is large whereas duty signal is small.

### 2. ENABLE CONDITION

Secondary Parameters	Enable Conditions
Battery voltage	$\geq 10.9$ V

### 3. GENERAL DRIVING CYCLE

Always perform the diagnosis continuously.

### 4. DIAGNOSTIC METHOD

#### Abnormality Judgment

Judge as NG when the continuous time of meeting the malfunction criteria below becomes 2 seconds or more.

#### Judgment Value

Malfunction Criteria	Threshold Value
Oil flow control solenoid valve control duty	$< 0.39\%$
Oil control solenoid valve control present current	$\geq 0.306$ A

**Time Needed for Diagnosis:** 2000 milliseconds

**Malfunction Indicator Light Illumination:** Illuminates as soon as a malfunction occurs.

#### Normality Judgment

Judge as OK and clear the NG when the continuous time with the following criteria established is more than 2 seconds.

#### Judgment Value

Malfunction Criteria	Threshold Value
Target current value of the oil flow control solenoid valve – Oil flow control solenoid valve control current value	$< 0.08$ A

### 5. DTC CLEAR CONDITION

- When the OK idling cycle is completed 40 times in a row
- When "Clear Memory" is performed

### 6. MALFUNCTION INDICATOR LIGHT CLEAR CONDITION

- When the OK driving cycle is completed 3 times in a row
- When "Clear Memory" is performed

# Diagnostic Trouble Code (DTC) Detecting Criteria

## GENERAL DESCRIPTION

---

### 7. FAIL SAFE

- Ignition timing whole learning compensation:
  - Enter the initial value (whole learning compensation factor = 0.5, Variable amount of whole learning compensation factor = 0.25) to the whole learning compensation factor and variable amount of whole learning compensation factor when IG OFF, and then make the whole learning incomplete.
  - Enter the initial value (whole learning compensation factor = 0.5, Variable amount of whole learning compensation factor = 0.25) to the whole learning compensation factor and variable amount of whole learning compensation factor when making a normality judgment → abnormality judgment, and then make the whole learning incomplete.
- Ignition timing partial learning compensation:
  - Enter the initial value (0°CA) to the compensation value of partial learning zone with IG OFF.
  - Enter the initial value (0°CA) to the compensation value of partial learning zone when making a normality judgment → abnormality judgment.
- AVCS control:
  - Maximum timing retard learning is not complete or maximum timing retard learning completion is not experienced.
  - ⇒ ISC feedback compensation: Do not perform the AVCS actual timing advance compensation.
  - Make the oil flow control solenoid valve drive duty a predetermined value (9.36%).

### 8. ECM OPERATION AT DTC SETTING

Memorize the freeze frame data. (For test mode \$02)



# Diagnostic Trouble Code (DTC) Detecting Criteria

GENERAL DESCRIPTION

## DZ:DTC P2092 OCV SOLENOID VALVE SIGNAL A CIRCUIT OPEN (BANK 2)

### 1. OUTLINE OF DIAGNOSIS

Detect open or short circuit of the oil flow control valve solenoid.

Judge open NG when the current flow is small whereas duty signal is large, and judge short NG when the current flow is large whereas duty signal is small.

### 2. ENABLE CONDITION

Secondary Parameters	Enable Conditions
Battery voltage	$\geq 10.9$ V

### 3. GENERAL DRIVING CYCLE

Always perform the diagnosis continuously.

### 4. DIAGNOSTIC METHOD

#### Abnormality Judgment

Judge as NG when the continuous time of meeting the malfunction criteria below becomes 2 seconds or more.

#### Judgment Value

Malfunction Criteria	Threshold Value
Oil flow control solenoid valve control duty	$\geq 99.61\%$
Oil control solenoid valve control present current	$< 0.306$ A

**Time Needed for Diagnosis:** 2000 milliseconds

**Malfunction Indicator Light Illumination:** Illuminates as soon as a malfunction occurs.

#### Normality Judgment

Judge as OK and clear the NG when the continuous time with the following criteria established is more than 2 seconds.

#### Judgment Value

Malfunction Criteria	Threshold Value
Target current value of the oil flow control solenoid valve	$\geq 0.14\%$
Target current value of the oil flow control solenoid valve – Oil flow control solenoid valve control current value	$\geq 0.08$ A

### 5. DTC CLEAR CONDITION

- When the OK idling cycle is completed 40 times in a row
- When “Clear Memory” is performed

### 6. MALFUNCTION INDICATOR LIGHT CLEAR CONDITION

- When the OK driving cycle is completed 3 times in a row
- When “Clear Memory” is performed

# Diagnostic Trouble Code (DTC) Detecting Criteria

## GENERAL DESCRIPTION

---

### 7. FAIL SAFE

- Ignition timing whole learning compensation:
  - Enter the initial value (whole learning compensation factor = 0.5, Variable amount of whole learning compensation factor = 0.25) to the whole learning compensation factor and variable amount of whole learning compensation factor when IG OFF, and then make the whole learning incomplete.
  - Enter the initial value (whole learning compensation factor = 0.5, Variable amount of whole learning compensation factor = 0.25) to the whole learning compensation factor and variable amount of whole learning compensation factor when making a normality judgment → abnormality judgment, and then make the whole learning incomplete.
- Ignition timing partial learning compensation:
  - Enter the initial value (0°CA) to the compensation value of partial learning zone with IG OFF.
  - Enter the initial value (0°CA) to the compensation value of partial learning zone when making a normality judgment → abnormality judgment.
- AVCS control:
  - Maximum timing retard learning is not complete or maximum timing retard learning completion is not experienced.
  - ⇒ ISC feedback compensation: Do not perform the AVCS actual timing advance compensation.
  - Make the oil flow control solenoid valve drive duty a predetermined value (9.36%).

### 8. ECM OPERATION AT DTC SETTING

Memorize the freeze frame data. (For test mode \$02)

# Diagnostic Trouble Code (DTC) Detecting Criteria

GENERAL DESCRIPTION

## EA:DTC P2093 INTAKE CAMSHAFT POSITION ACTUATOR CONTROL CIRCUIT HIGH (BANK 2)

### 1. OUTLINE OF DIAGNOSIS

Detect open or short circuit of the oil flow control valve solenoid.

Judge open NG when the current flow is small whereas duty signal is large, and judge short NG when the current flow is large whereas duty signal is small.

### 2. ENABLE CONDITION

Secondary Parameters	Enable Conditions
Battery voltage	$\geq 10.9$ V

### 3. GENERAL DRIVING CYCLE

Always perform the diagnosis continuously.

### 4. DIAGNOSTIC METHOD

#### Abnormality Judgment

Judge as NG when the continuous time of meeting the malfunction criteria below becomes 2 seconds or more.

#### Judgment Value

Malfunction Criteria	Threshold Value
Oil flow control solenoid valve control duty	$< 0.39\%$
Oil control solenoid valve control present current	$\geq 0.306$ A

**Time Needed for Diagnosis:** 2000 milliseconds

**Malfunction Indicator Light Illumination:** Illuminates as soon as a malfunction occurs.

#### Normality Judgment

Judge as OK and clear the NG when the continuous time with the following criteria established is more than 2 seconds.

#### Judgment Value

Malfunction Criteria	Threshold Value
Target current value of the oil flow control solenoid valve – Oil flow control solenoid valve control current value	$< 0.08$ A

### 5. DTC CLEAR CONDITION

- When the OK idling cycle is completed 40 times in a row
- When “Clear Memory” is performed

### 6. MALFUNCTION INDICATOR LIGHT CLEAR CONDITION

- When the OK driving cycle is completed 3 times in a row
- When “Clear Memory” is performed

# Diagnostic Trouble Code (DTC) Detecting Criteria

## GENERAL DESCRIPTION

---

### 7. FAIL SAFE

- Ignition timing whole learning compensation:
  - Enter the initial value (whole learning compensation factor = 0.5, Variable amount of whole learning compensation factor = 0.25) to the whole learning compensation factor and variable amount of whole learning compensation factor when IG OFF, and then make the whole learning incomplete.
  - Enter the initial value (whole learning compensation factor = 0.5, Variable amount of whole learning compensation factor = 0.25) to the whole learning compensation factor and variable amount of whole learning compensation factor when making a normality judgment → abnormality judgment, and then make the whole learning incomplete.
- Ignition timing partial learning compensation:
  - Enter the initial value (0°C) to the compensation value of partial learning zone with IG OFF.
  - Enter the initial value (0°C) to the compensation value of partial learning zone when making a normality judgment → abnormality judgment.
- AVCS control:
  - Maximum timing retard learning is not complete or maximum timing retard learning completion is not experienced.
  - ISC feedback compensation: Do not perform the AVCS actual timing advance compensation.
  - Make the oil flow control solenoid valve drive duty a predetermined value (9.36%).

### 8. ECM OPERATION AT DTC SETTING

Memorize the freeze frame data. (For test mode \$02)

## EB:DTC P2096 POST CATALYST FUEL TRIM SYSTEM TOO LEAN BANK 1

### 1. OUTLINE OF DIAGNOSIS

Detect abnormalities in the fuel system by determining whether the sub feedback compensation amount is shifting to rich or lean. If the sub feedback compensation amount from engine start to ignition off is shifting to rich or lean, there is insufficient compensation. → If it is insufficient, change the sub feedback compensation guard value, shift judgment line, and increment the guard operation counter (temporary NG counter). When the guard operation counter (temporary NG counter) exceeds the set value, and the sub feedback compensation is shifting to rich or lean, it is judged as NG.

### 2. COMPONENT DESCRIPTION

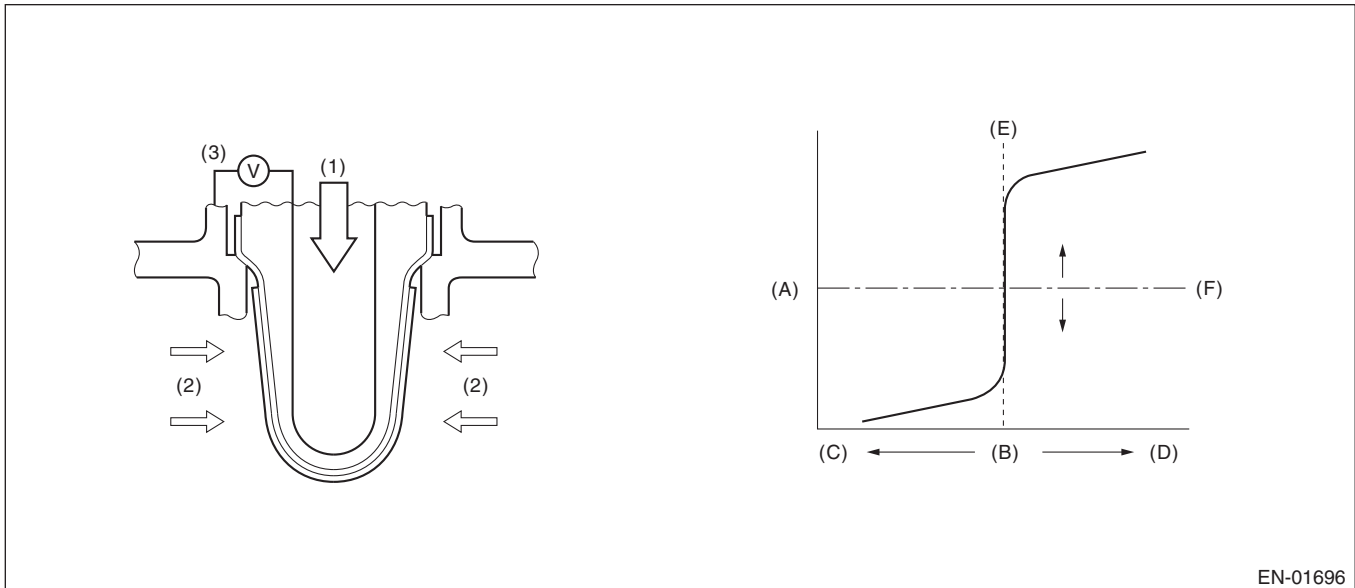

EN-01696

- (1) Atmosphere
- (2) Exhaust gas
- (3) Electromotive force

- (A) Electromotive force
- (B) Air fuel ratio
- (C) Rich
- (D) Lean
- (E) Theoretical air fuel ratio
- (F) Comparative voltage

### 3. ENABLE CONDITION

Secondary Parameters	Enable Conditions
Continuous time when the following conditions are established	1 second or more
Conditions for carrying out the sub feedback learning	Complete

### 4. GENERAL DRIVING CYCLE

Perform the diagnosis continuously at a constant speed of approx. 75 km/h (47 MPH) or higher.

# Diagnostic Trouble Code (DTC) Detecting Criteria

## GENERAL DESCRIPTION

---

### 5. DIAGNOSTIC METHOD

Judge as NG when the continuous time when the following conditions are established is more than 5 seconds. Judge as OK and clear the NG when the following conditions are not established for a continuous time of 5 seconds or more.

#### Judgment Value

Malfunction Criteria	Threshold Value
Sub feedback learning value	< -0.018

**Time Needed for Diagnosis:** 5 seconds

**Malfunction Indicator Light Illumination:** Illuminates when malfunction occurs in 2 continuous driving cycles.

### 6. DTC CLEAR CONDITION

- When the OK idling cycle is completed 40 times in a row
- When "Clear Memory" is performed

### 7. MALFUNCTION INDICATOR LIGHT CLEAR CONDITION

- When similar driving conditions are repeated 3 times and the result is OK.
- When "Clear Memory" is performed

### 8. FAIL SAFE

None

### 9. ECM OPERATION AT DTC SETTING

Memorize the freeze frame data. (For test mode \$02)

## EC:DTC P2097 POST CATALYST FUEL TRIM SYSTEM TOO RICH BANK 1

### 1. OUTLINE OF DIAGNOSIS

Detect abnormalities in the fuel system by determining whether the sub feedback compensation amount is shifting to rich or lean. If the sub feedback compensation amount from engine start to ignition off is shifting to rich or lean, there is insufficient compensation. → If it is insufficient, change the sub feedback compensation guard value, shift judgment line, and increment the guard operation counter (temporary NG counter). When the guard operation counter (temporary NG counter) exceeds the set value, and the sub feedback compensation is shifting to rich or lean, it is judged as NG.

### 2. COMPONENT DESCRIPTION

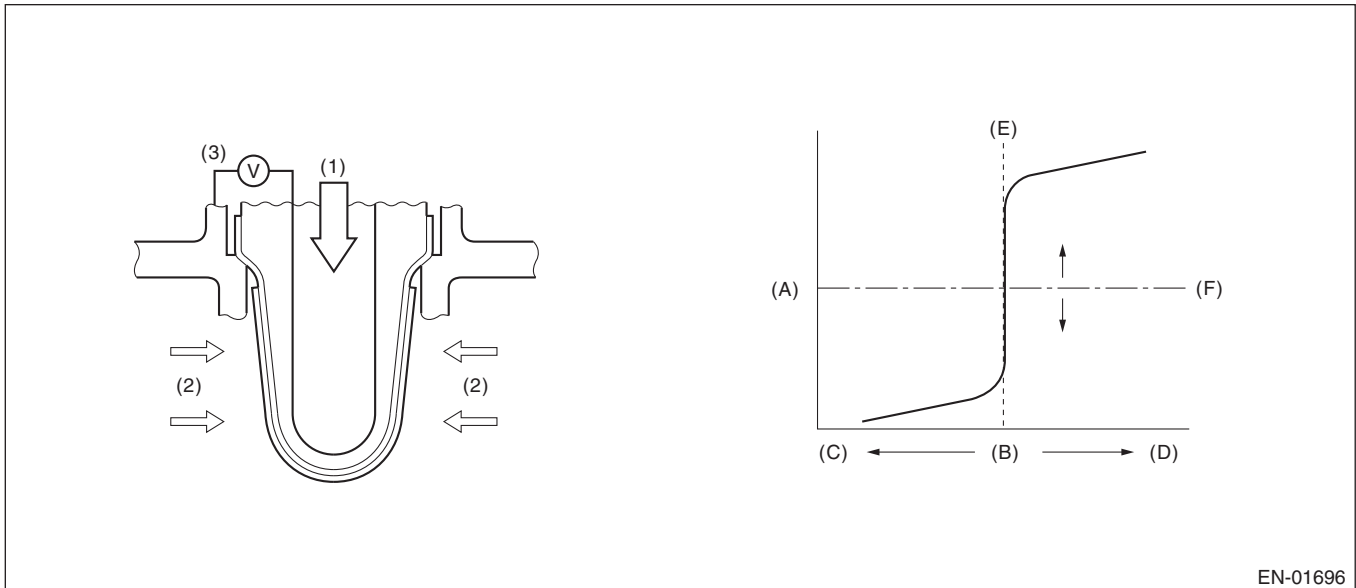

EN-01696

- (1) Atmosphere
- (2) Exhaust gas
- (3) Electromotive force

- (A) Electromotive force
- (B) Air fuel ratio
- (C) Rich
- (D) Lean
- (E) Theoretical air fuel ratio
- (F) Comparative voltage

### 3. ENABLE CONDITION

Secondary Parameters	Enable Conditions
Continuous time when the following conditions are established	1 second or more
Conditions for carrying out the sub feedback learning	Complete

### 4. GENERAL DRIVING CYCLE

Perform the diagnosis continuously at a constant speed of approx. 75 km/h (47 MPH) or higher.

# Diagnostic Trouble Code (DTC) Detecting Criteria

## GENERAL DESCRIPTION

---

### 5. DIAGNOSTIC METHOD

Judge as NG when the continuous time when the following conditions are established is more than 5 seconds. Judge as OK and clear the NG when the following conditions are not established for a continuous time of 5 seconds or more.

#### Judgment Value

Malfunction Criteria	Threshold Value
Sub feedback learning value	$\geq 0.018$
Count of limits moving to rich	$\geq 4$ times
Ratio of time for oxygen sensor upper or lower to time or rich time/lean tim	$\leq 9$ (AT model) $\leq 5.7$ (MT model)

**Time Needed for Diagnosis:** 5 seconds

**Malfunction Indicator Light Illumination:** Illuminates when malfunction occurs in 2 continuous driving cycles.

### 6. DTC CLEAR CONDITION

- When the OK idling cycle is completed 40 times in a row
- When "Clear Memory" is performed

### 7. MALFUNCTION INDICATOR LIGHT CLEAR CONDITION

- When similar driving conditions are repeated 3 times and the result is OK.
- When "Clear Memory" is performed

### 8. FAIL SAFE

None

### 9. ECM OPERATION AT DTC SETTING

Memorize the freeze frame data. (For test mode \$02)



## ED:DTC P2101 THROTTLE ACTUATOR CONTROL MOTOR CIRCUIT RANGE/ PERFORMANCE

### 1. OUTLINE OF DIAGNOSIS

Judge as NG when the motor current becomes too large or drive circuit is heated.

### 2. COMPONENT DESCRIPTION

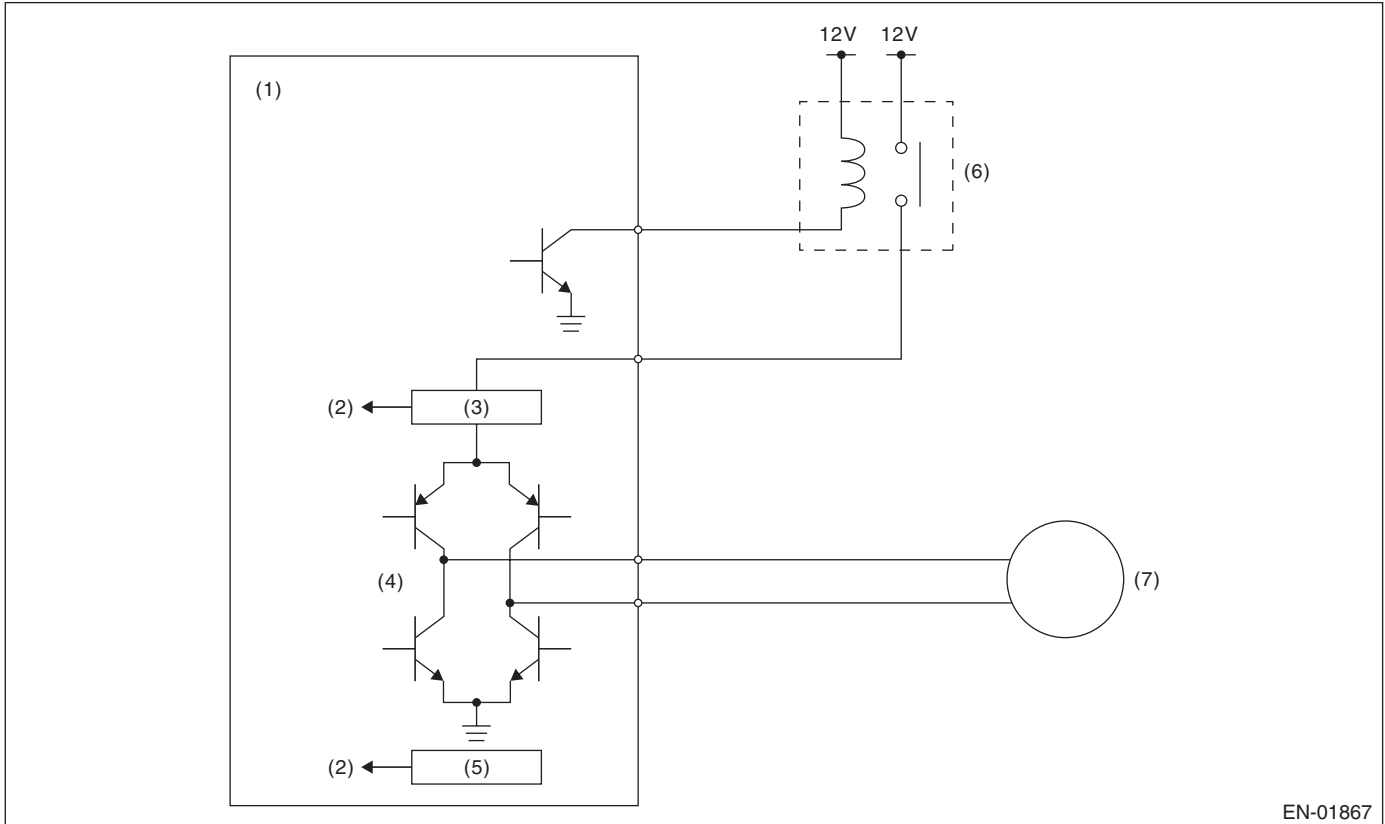

- |                                   |                                       |
|-----------------------------------|---------------------------------------|
| (1) Engine control module (ECM)   | (5) Temperature detection circuit     |
| (2) Detecting circuit             | (6) Electronic throttle control relay |
| (3) Overcurrent detection circuit | (7) Motor                             |
| (4) Drive circuit                 |                                       |

### 3. ENABLE CONDITION

Secondary Parameters	Enable Conditions
Under control of electronic throttle control	ON
Ignition switch	ON

### 4. GENERAL DRIVING CYCLE

Always perform the diagnosis continuously.

# Diagnostic Trouble Code (DTC) Detecting Criteria

## GENERAL DESCRIPTION

---

### 5. DIAGNOSTIC METHOD

#### Abnormality Judgment

Judge as OK and clear the NG when the malfunction criteria below are met.

#### Judgment Value

Malfunction Criteria	Threshold Value
Motor current	$\leq 8$ A
Drive circuit inner temperature	$\leq 175^{\circ}\text{C}$ (347°F)

#### Time Needed for Diagnosis:

- 500 milliseconds (For NG)
- 2000 milliseconds (For OK)

**Malfunction Indicator Light Illumination:** Illuminates as soon as a malfunction occurs.

### 6. DTC CLEAR CONDITION

- When the OK idling cycle is completed 40 times in a row
- When "Clear Memory" is performed (Only with engine stopped)

### 7. MALFUNCTION INDICATOR LIGHT CLEAR CONDITION

- When the OK driving cycle is completed 3 times in a row
- When "Clear Memory" is performed (Only with engine stopped)

### 8. FAIL SAFE

Stop the continuity to the electronic throttle control motor. (Throttle opening is fixed to 6°.)

### 9. ECM OPERATION AT DTC SETTING

Memorize the freeze frame data. (For test mode \$02)

## EE:DTC P2102 THROTTLE ACTUATOR CONTROL MOTOR CIRCUIT LOW

### 1. OUTLINE OF DIAGNOSIS

Judge as NG when the electronic throttle control power is not supplied even when ECM sets the electric throttle control relay to ON.

### 2. COMPONENT DESCRIPTION

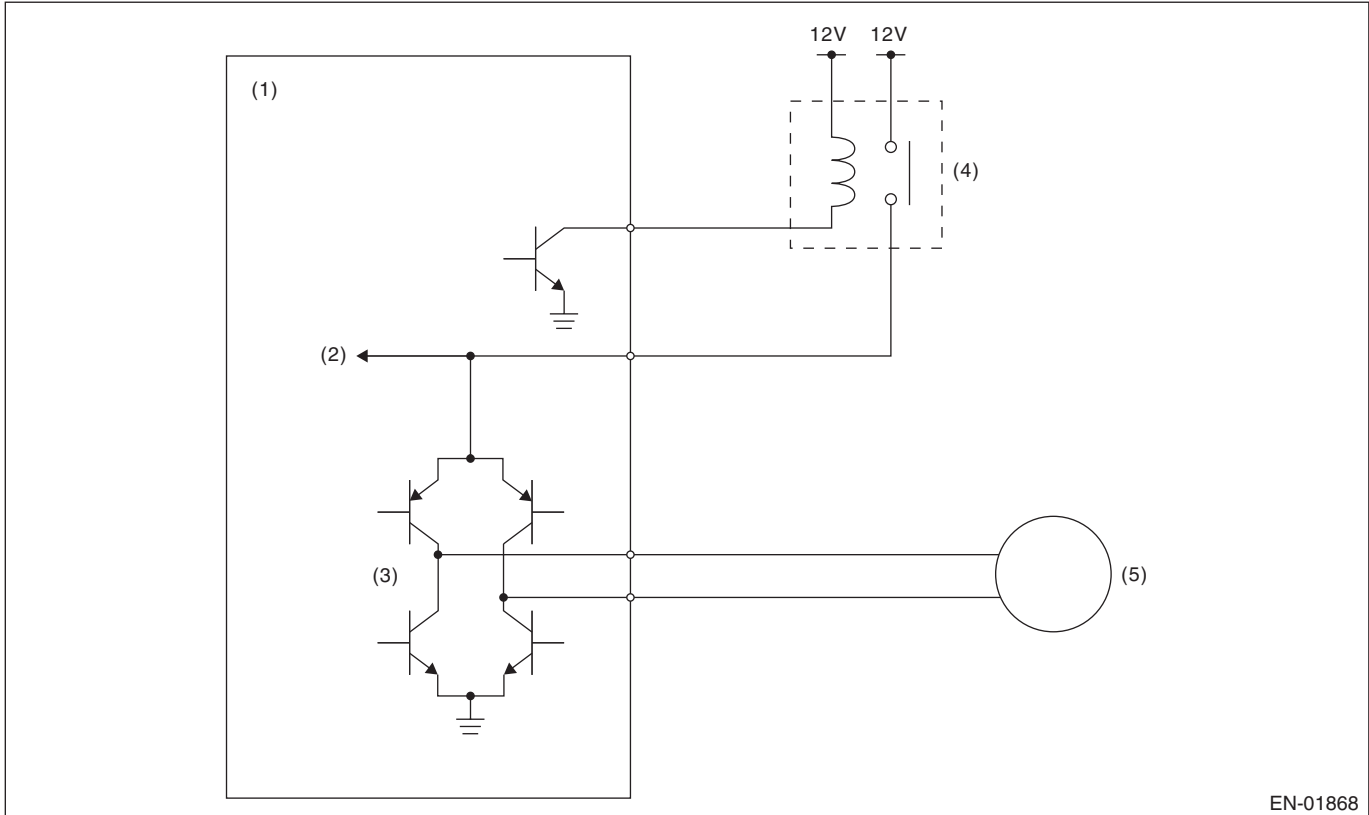

EN-01868

- (1) Engine control module (ECM)
- (2) Voltage detection circuit
- (3) Drive circuit
- (4) Electronic throttle control relay
- (5) Motor

### 3. ENABLE CONDITION

Secondary Parameters	Enable Conditions
electronic throttle control relay output	ON
Battery voltage	$\geq 6\text{ V}$

### 4. GENERAL DRIVING CYCLE

Always perform the diagnosis continuously.

# Diagnostic Trouble Code (DTC) Detecting Criteria

## GENERAL DESCRIPTION

---

### 5. DIAGNOSTIC METHOD

#### Abnormality Judgment

Judge as NG when the continuous time of meeting the malfunction criteria below becomes 0.5 seconds or more.

#### Judgment Value

Malfunction Criteria	Threshold Value
Motor power voltage	$\leq 5 \text{ V}$

#### Time Needed for Diagnosis:

- 400 milliseconds (For NG)
- 2000 milliseconds (For OK)

**Malfunction Indicator Light Illumination:** Illuminates as soon as a malfunction occurs.

### 6. DTC CLEAR CONDITION

- When the OK idling cycle is completed 40 times in a row
- When "Clear Memory" is performed (Only with engine stopped)

### 7. MALFUNCTION INDICATOR LIGHT CLEAR CONDITION

- When the OK driving cycle is completed 3 times in a row
- When "Clear Memory" is performed (Only with engine stopped)

### 8. FAIL SAFE

Stop the continuity to the electronic throttle control motor. (Throttle opening is fixed to 6°.)

### 9. ECM OPERATION AT DTC SETTING

Memorize the freeze frame data. (For test mode \$02)

## EF:DTC P2103 THROTTLE ACTUATOR CONTROL MOTOR CIRCUIT HIGH

### 1. OUTLINE OF DIAGNOSIS

Judge as NG when the electronic throttle control power is supplied even when ECM sets the electric throttle control relay to OFF.

### 2. COMPONENT DESCRIPTION

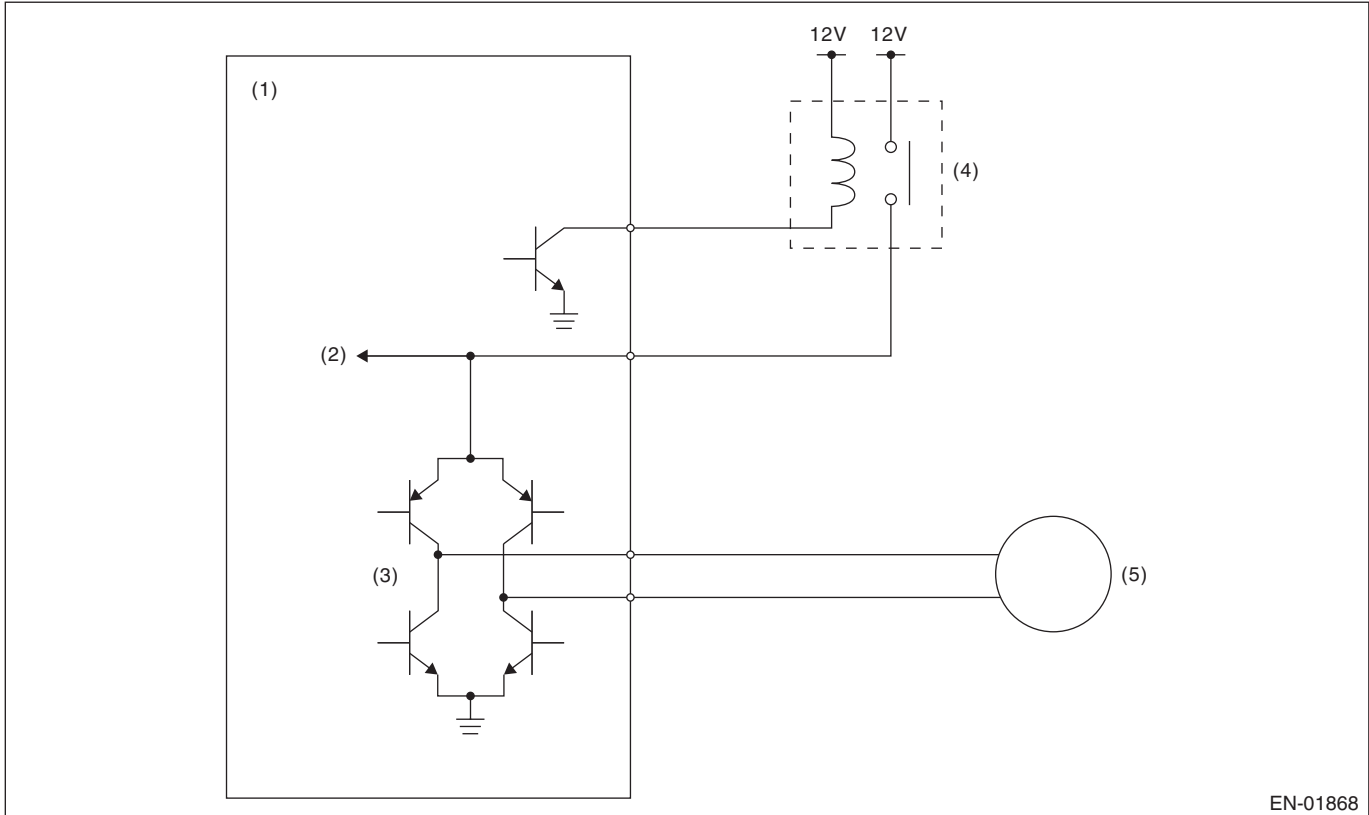

EN-01868

- (1) Engine control module (ECM)
- (2) Voltage detection circuit
- (3) Drive circuit
- (4) Electronic throttle control relay
- (5) Motor

### 3. ENABLE CONDITION

Secondary Parameters	Enable Conditions
electronic throttle control relay output	OFF
Battery voltage	≥ 6 V

### 4. GENERAL DRIVING CYCLE

- When ignition switch ON → OFF
- Ignition switch OFF → ON (Only after clearing memory)

# Diagnostic Trouble Code (DTC) Detecting Criteria

## GENERAL DESCRIPTION

---

### 5. DIAGNOSTIC METHOD

Judge as OK and clear the NG when the malfunction criteria below are met.

#### Judgment Value

Malfunction Criteria	Threshold Value
Motor power voltage	$\leq 5$ V

#### Time Needed for Diagnosis:

- 600 milliseconds (For NG)
- 400 milliseconds (For OK)

**Malfunction Indicator Light Illumination:** Illuminates as soon as a malfunction occurs.

### 6. DTC CLEAR CONDITION

- When the OK idling cycle is completed 40 times in a row
- When "Clear Memory" is performed (Only with engine stopped)

### 7. MALFUNCTION INDICATOR LIGHT CLEAR CONDITION

- When the OK driving cycle is completed 3 times in a row
- When "Clear Memory" is performed (Only with engine stopped)

### 8. FAIL SAFE

Stop the continuity to the electronic throttle control motor. (Throttle opening is fixed to 6°.)

### 9. ECM OPERATION AT DTC SETTING

Memorize the freeze frame data. (For test mode \$02)

## EG:DTC P2109 THROTTLE/PEDAL POSITION SENSOR “A” MINIMUM STOP PERFORMANCE

### 1. OUTLINE OF DIAGNOSIS

Judge as NG when fully close point learning cannot conducted or outside the standard value.

### 2. COMPONENT DESCRIPTION

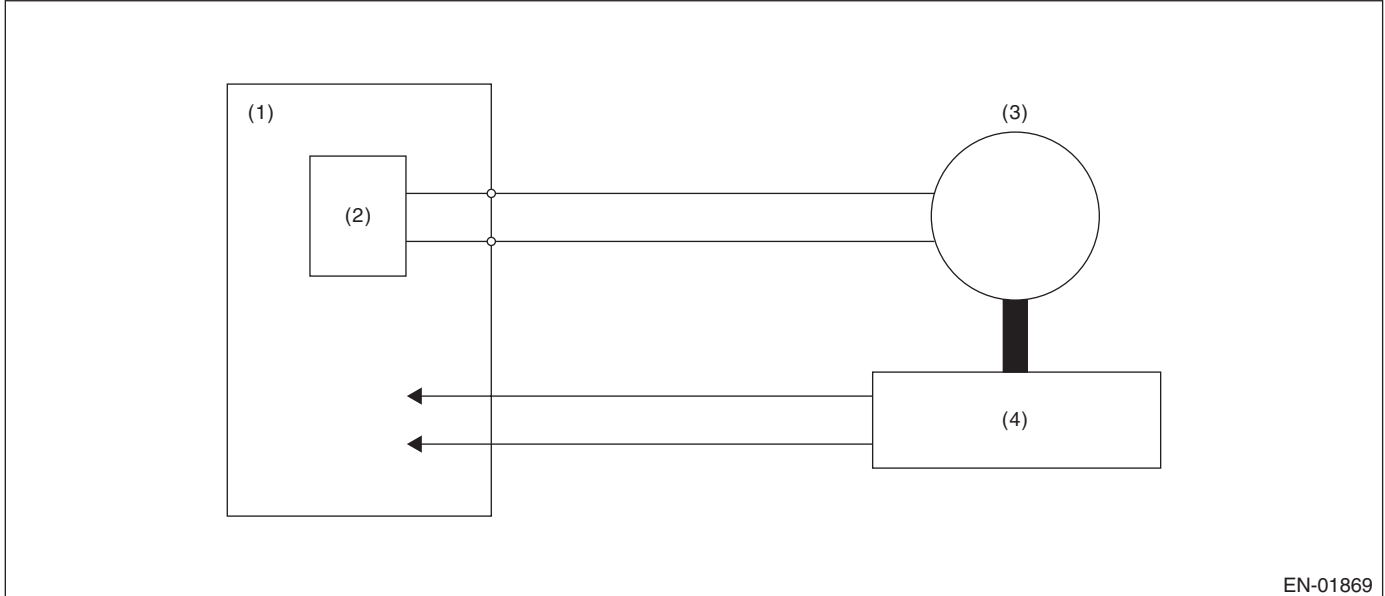

- (1) Engine control module (ECM)
- (2) Drive circuit
- (3) Motor
- (4) Throttle position sensor

### 3. ENABLE CONDITION

Secondary Parameters	Enable Conditions
Ignition switch	ON → OFF
Ignition switch (only after cleaning the memory)	OFF → ON

### 4. GENERAL DRIVING CYCLE

Perform the diagnosis at full closed point learning.

### 5. DIAGNOSTIC METHOD

Judge as OK and clear the NG when the malfunction criteria below are met.

#### Judgment Value

Malfunction Criteria	Threshold Value
Throttle sensor opening angle at all close point learning	10.127° or more, 19.872° or less
Throttle opening angle when the ignition switch is ON – Throttle minimum stop position	≥ 1.683°

**Time Needed for Diagnosis:** 8 — 80 milliseconds

**Malfunction Indicator Light Illumination:** Illuminates as soon as a malfunction occurs.

# Diagnostic Trouble Code (DTC) Detecting Criteria

## GENERAL DESCRIPTION

---

### 6. DTC CLEAR CONDITION

- When the OK idling cycle is completed 40 times in a row
- When "Clear Memory" is performed (Only with engine stopped)

### 7. MALFUNCTION INDICATOR LIGHT CLEAR CONDITION

- When the OK driving cycle is completed 3 times in a row
- When "Clear Memory" is performed (Only with engine stopped)

### 8. FAIL SAFE

Stop the continuity to the electronic throttle control motor. (Throttle opening is fixed to 6°.)

### 9. ECM OPERATION AT DTC SETTING

Memorize the freeze frame data. (For test mode \$02)



## EH:DTC P2122 THROTTLE/PEDAL POSITION SENSOR/SWITCH “D” CIRCUIT LOW INPUT

### 1. OUTLINE OF DIAGNOSIS

Detect the open or short circuit of accelerator pedal position sensor 1.  
 Judge as NG if it is out of specification.

### 2. COMPONENT DESCRIPTION

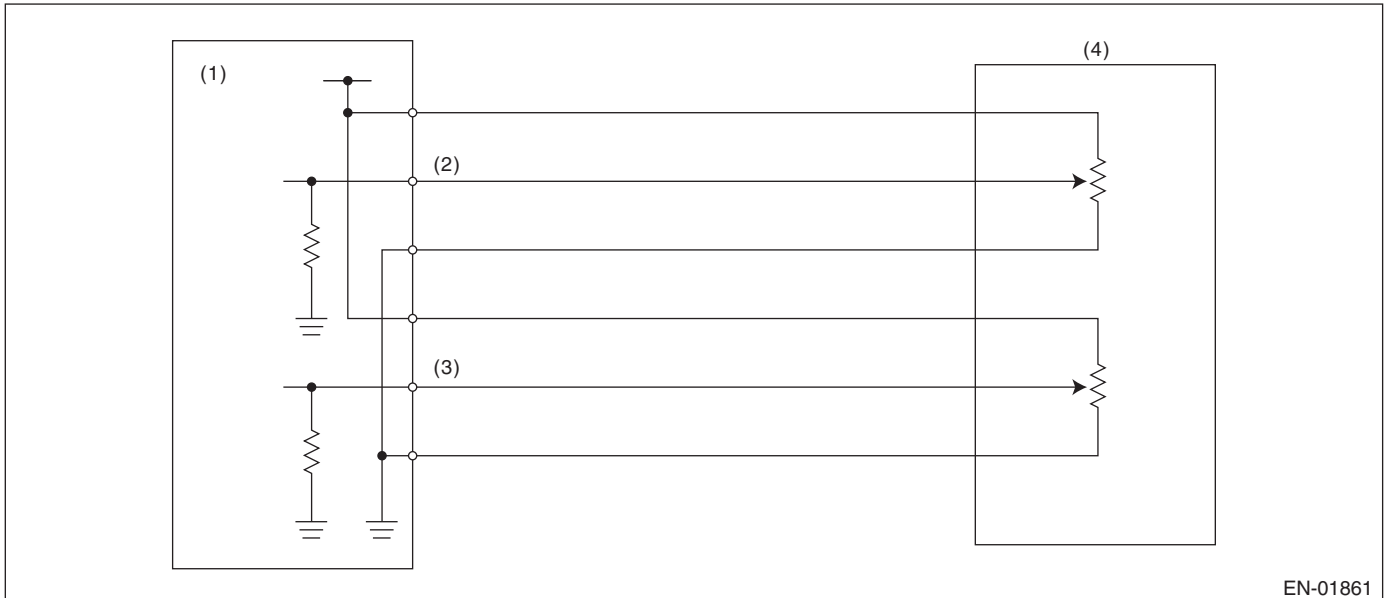

EN-01861

- (1) Engine control module (ECM)
- (2) Accelerator pedal position sensor 1 signal
- (3) Accelerator pedal position sensor 2 signal
- (4) Accelerator pedal position sensor

### 3. ENABLE CONDITION

Secondary Parameters	Enable Conditions
Ignition switch	ON

### 4. GENERAL DRIVING CYCLE

Always perform the diagnosis continuously.

### 5. DIAGNOSTIC METHOD

Judge as OK and clear the NG when the malfunction criteria below are met.

#### Judgment Value

Malfunction Criteria	Threshold Value
Sensor 1 input voltage	$\geq 0.219$ V

**Time Needed for Diagnosis:** 100 milliseconds

**Malfunction Indicator Light Illumination:** Illuminates as soon as a malfunction occurs.

### 6. DTC CLEAR CONDITION

- When the OK idling cycle is completed 40 times in a row
- When “Clear Memory” is performed (Only with engine stopped)

### 7. MALFUNCTION INDICATOR LIGHT CLEAR CONDITION

- When the OK driving cycle is completed 3 times in a row
- When “Clear Memory” is performed (Only with engine stopped)

# Diagnostic Trouble Code (DTC) Detecting Criteria

## GENERAL DESCRIPTION

---

### 8. FAIL SAFE

- Single malfunction: Control with normal sensor
- Simultaneous failure: Throttle opening is fixed to 6°.

### 9. ECM OPERATION AT DTC SETTING

Memorize the freeze frame data. (For test mode \$02)

## EI: DTC P2123 THROTTLE/PEDAL POSITION SENSOR/SWITCH “D” CIRCUIT HIGH INPUT

### 1. OUTLINE OF DIAGNOSIS

Detect the open or short circuit of accelerator pedal position sensor 1.  
Judge as NG if it is out of specification.

### 2. COMPONENT DESCRIPTION

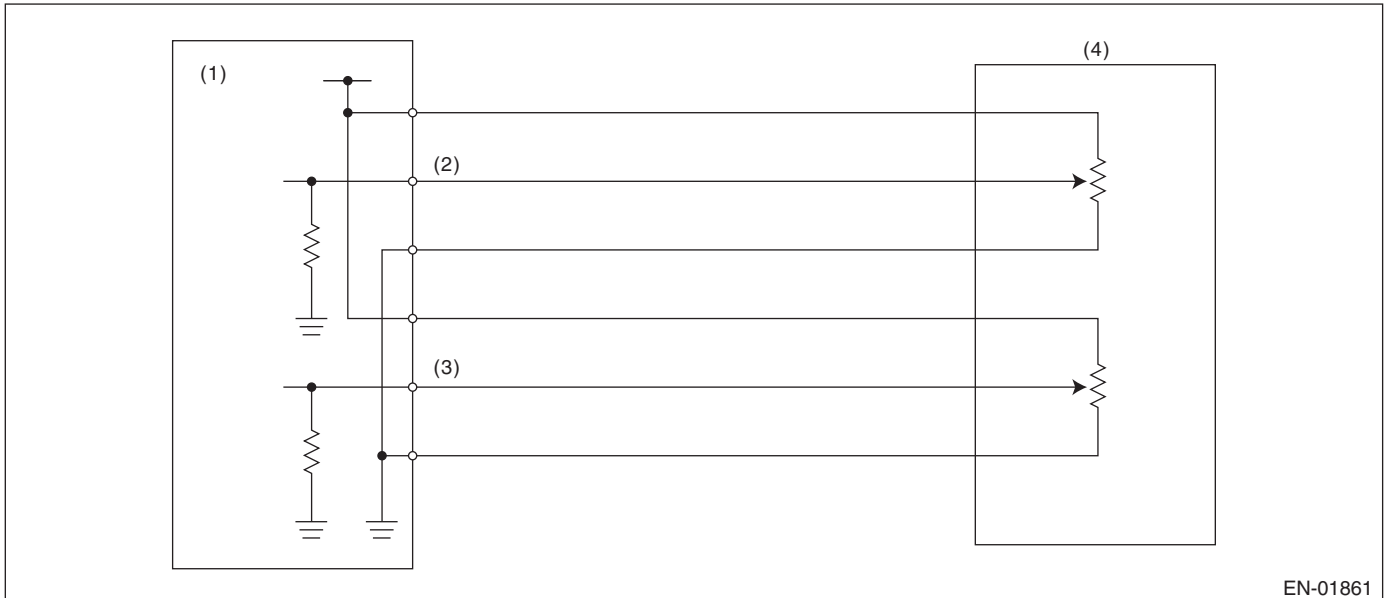

EN-01861

- (1) Engine control module (ECM)
- (2) Accelerator pedal position sensor 1 signal
- (3) Accelerator pedal position sensor 2 signal
- (4) Accelerator pedal position sensor

### 3. ENABLE CONDITION

Secondary Parameters	Enable Conditions
Ignition switch	ON

### 4. GENERAL DRIVING CYCLE

Always perform the diagnosis continuously.

### 5. DIAGNOSTIC METHOD

Judge as OK and clear the NG when the malfunction criteria below are met.

#### Judgment Value

Malfunction Criteria	Threshold Value
Sensor 1 input voltage	$\leq 4.781$ V

**Time Needed for Diagnosis:** 100 milliseconds

**Malfunction Indicator Light Illumination:** Illuminates as soon as a malfunction occurs.

### 6. DTC CLEAR CONDITION

- When the OK idling cycle is completed 40 times in a row
- When “Clear Memory” is performed (Only with engine stopped)

### 7. MALFUNCTION INDICATOR LIGHT CLEAR CONDITION

- When the OK driving cycle is completed 3 times in a row
- When “Clear Memory” is performed (Only with engine stopped)

# Diagnostic Trouble Code (DTC) Detecting Criteria

## GENERAL DESCRIPTION

---

### 8. FAIL SAFE

- Single malfunction: Control with normal sensor
- Simultaneous failure: Throttle opening is fixed to 6°.

### 9. ECM OPERATION AT DTC SETTING

Memorize the freeze frame data. (For test mode \$02)

## EJ: DTC P2127 THROTTLE/PEDAL POSITION SENSOR/SWITCH “E” CIRCUIT LOW INPUT

### 1. OUTLINE OF DIAGNOSIS

Detect the open or short circuit of accelerator pedal position sensor 2.  
 Judge as NG if it is out of specification.

### 2. COMPONENT DESCRIPTION

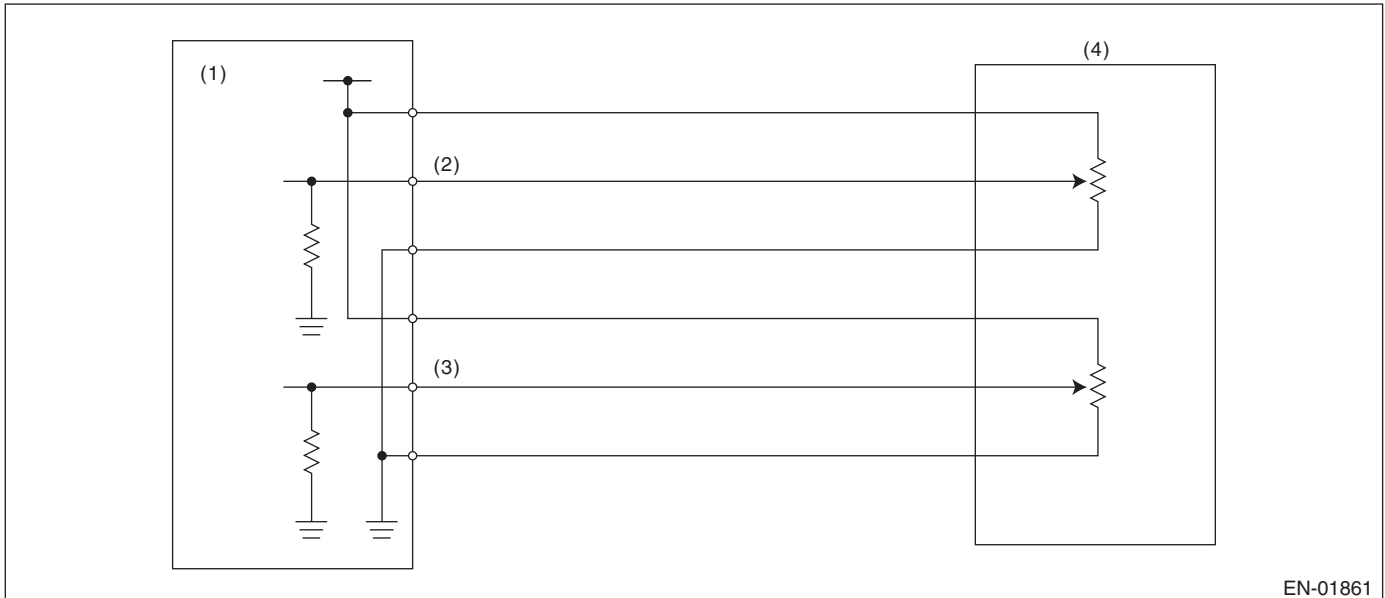

- (1) Engine control module (ECM)
- (2) Accelerator pedal position sensor 1 signal
- (3) Accelerator pedal position sensor 2 signal
- (4) Accelerator pedal position sensor

### 3. ENABLE CONDITION

Secondary Parameters	Enable Conditions
Ignition switch	ON

### 4. GENERAL DRIVING CYCLE

Always perform the diagnosis continuously.

### 5. DIAGNOSTIC METHOD

Judge as OK and clear the NG when the malfunction criteria below are met.

#### Judgment Value

Malfunction Criteria	Threshold Value
Sensor 1 input voltage	≥ 0.219 V

**Time Needed for Diagnosis:** 100 milliseconds

**Malfunction Indicator Light Illumination:** Illuminates as soon as a malfunction occurs.

### 6. DTC CLEAR CONDITION

- When the OK idling cycle is completed 40 times in a row
- When “Clear Memory” is performed (Only with engine stopped)

### 7. MALFUNCTION INDICATOR LIGHT CLEAR CONDITION

- When the OK driving cycle is completed 3 times in a row
- When “Clear Memory” is performed (Only with engine stopped)

# Diagnostic Trouble Code (DTC) Detecting Criteria

## GENERAL DESCRIPTION

---

### 8. FAIL SAFE

- Single malfunction: Control with normal sensor
- Simultaneous failure: Throttle opening is fixed to 6°.

### 9. ECM OPERATION AT DTC SETTING

Memorize the freeze frame data. (For test mode \$02)

## EK:DTC P2128 THROTTLE/PEDAL POSITION SENSOR/SWITCH “E” CIRCUIT HIGH INPUT

### 1. OUTLINE OF DIAGNOSIS

Detect the open or short circuit of accelerator pedal position sensor 2.  
 Judge as NG if it is out of specification.

### 2. COMPONENT DESCRIPTION

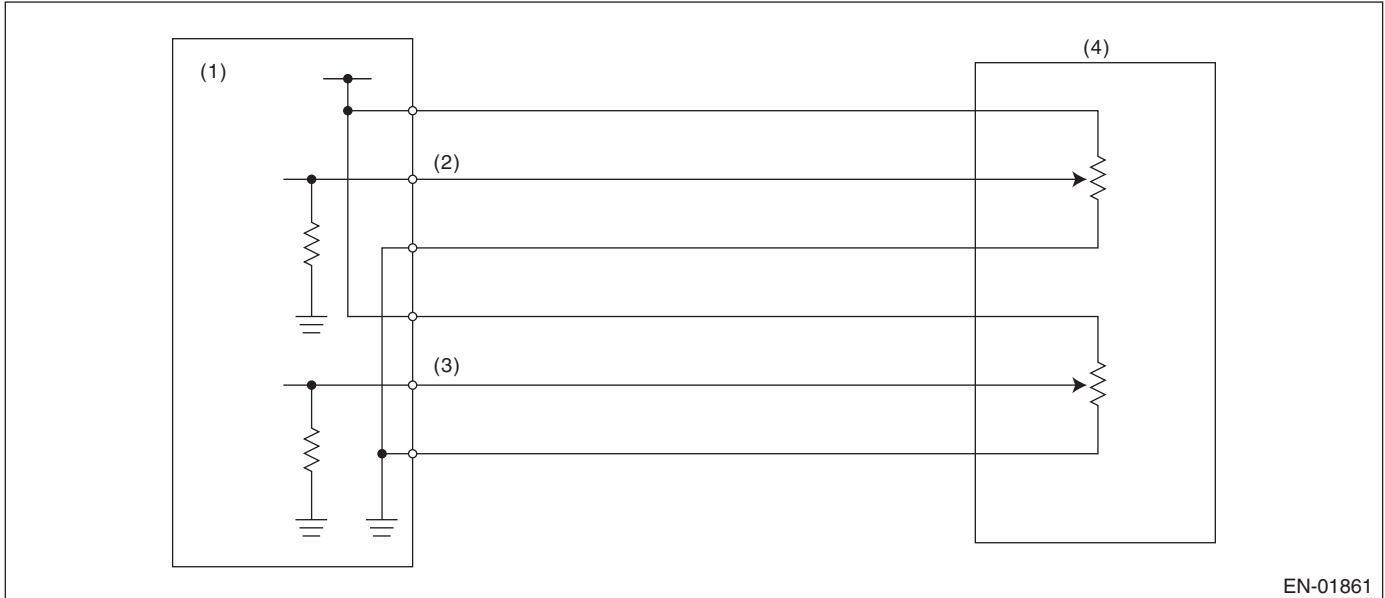

EN-01861

- (1) Engine control module (ECM)
- (2) Accelerator pedal position sensor 1 signal
- (3) Accelerator pedal position sensor 2 signal
- (4) Accelerator pedal position sensor

### 3. ENABLE CONDITION

Secondary Parameters	Enable Conditions
Ignition switch	ON

### 4. GENERAL DRIVING CYCLE

Always perform the diagnosis continuously.

### 5. DIAGNOSTIC METHOD

Judge as OK and clear the NG when the malfunction criteria below are met.

#### Judgment Value

Malfunction Criteria	Threshold Value
Sensor 1 input voltage	≤ 4.781 V

**Time Needed for Diagnosis:** 100 milliseconds

**Malfunction Indicator Light Illumination:** Illuminates as soon as a malfunction occurs.

### 6. DTC CLEAR CONDITION

- When the OK idling cycle is completed 40 times in a row
- When “Clear Memory” is performed (Only with engine stopped)

### 7. MALFUNCTION INDICATOR LIGHT CLEAR CONDITION

- When the OK driving cycle is completed 3 times in a row
- When “Clear Memory” is performed (Only with engine stopped)

# Diagnostic Trouble Code (DTC) Detecting Criteria

## GENERAL DESCRIPTION

---

### 8. FAIL SAFE

- Single malfunction: Control with normal sensor
- Simultaneous failure: Throttle opening is fixed to 6°.

### 9. ECM OPERATION AT DTC SETTING

Memorize the freeze frame data. (For test mode \$02)



## EL:DTC P2135 THROTTLE/PEDAL POSITION SENSOR/SWITCH “A”/“B” VOLTAGE CORRELATION

### 1. OUTLINE OF DIAGNOSIS

Judge as NG when the signal level of accelerator pedal position sensor 1 is different from the throttle position sensor 2.

### 2. COMPONENT DESCRIPTION

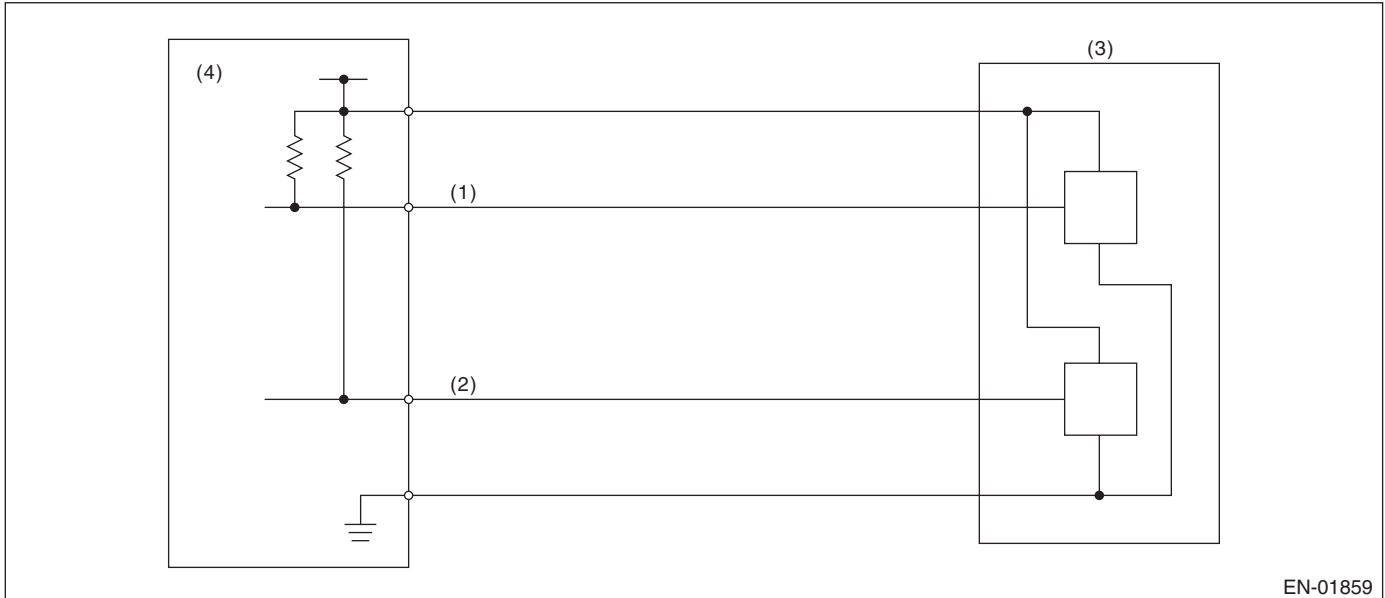

- (1) Throttle position sensor 1 signal
- (2) Throttle position sensor 2 signal
- (3) Throttle position sensor
- (4) Engine control module (ECM)

### 3. ENABLE CONDITION

Secondary Parameters	Enable Conditions
Ignition switch	ON

### 4. GENERAL DRIVING CYCLE

Always perform the diagnosis continuously.

# Diagnostic Trouble Code (DTC) Detecting Criteria

## GENERAL DESCRIPTION

### 5. DIAGNOSTIC METHOD

Judge as OK and clear the NG when the malfunction criteria below are met.

#### Judgment Value

Malfunction Criteria	Threshold Value
Signal difference between two sensors	$\leq 4.25$

#### Details of Judgment Value

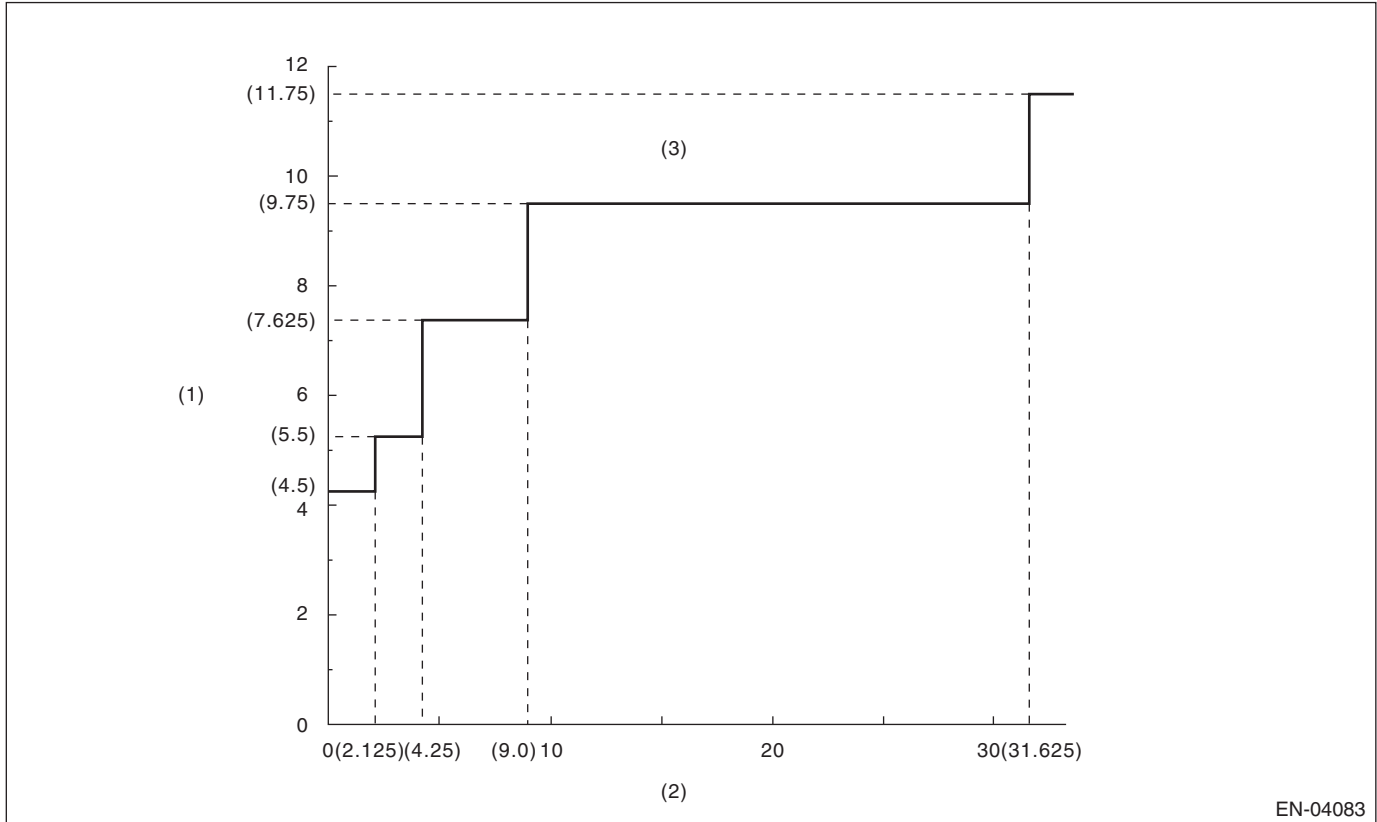

- (1) Sensor output difference (°)
- (2) Throttle position sensor 1 opening angle (°)
- (3) NG area

**Time Needed for Diagnosis:** 212 milliseconds

**Malfunction Indicator Light Illumination:** Illuminates as soon as a malfunction occurs.

### 6. DTC CLEAR CONDITION

- When the OK idling cycle is completed 40 times in a row
- When "Clear Memory" is performed (Only with engine stopped)

### 7. MALFUNCTION INDICATOR LIGHT CLEAR CONDITION

- When the OK driving cycle is completed 3 times in a row
- When "Clear Memory" is performed (Only with engine stopped)

### 8. FAIL SAFE

Stop the continuity to ETC motor. (Throttle opening is fixed to 6°.)

### 9. ECM OPERATION AT DTC SETTING

Memorize the freeze frame data. (For test mode \$02)

## EM:DTC P2138 THROTTLE/PEDAL POSITION SENSOR/SWITCH “D”/“E” VOLTAGE CORRELATION

### 1. OUTLINE OF DIAGNOSIS

Judge as NG when the signal level of throttle position sensor 1 is different from the throttle position sensor 2.

### 2. COMPONENT DESCRIPTION

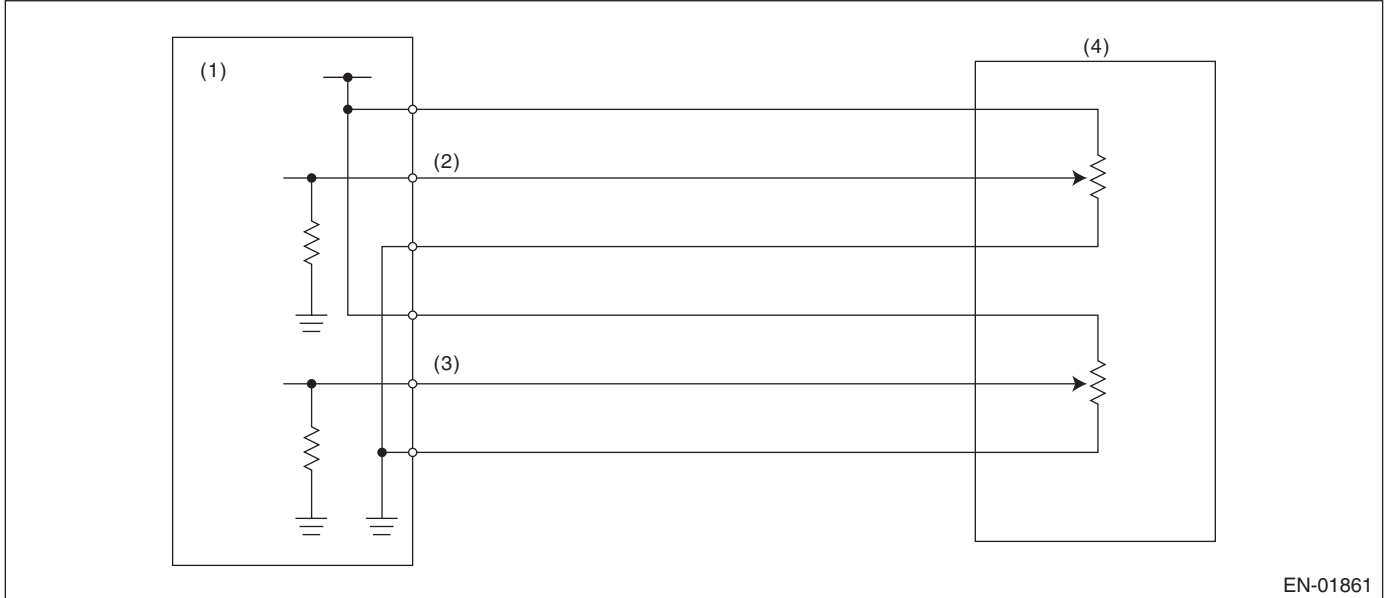

EN-01861

- (1) Engine control module (ECM)
- (2) Accelerator pedal position sensor 1 signal
- (3) Accelerator pedal position sensor 2 signal
- (4) Accelerator pedal position sensor

### 3. ENABLE CONDITION

Secondary Parameters	Enable Conditions
Ignition switch	ON

### 4. GENERAL DRIVING CYCLE

Always perform the diagnosis continuously.

# Diagnostic Trouble Code (DTC) Detecting Criteria

## GENERAL DESCRIPTION

### 5. DIAGNOSTIC METHOD

Judge as OK and clear the NG when the malfunction criteria below are met.

#### Judgment Value

Malfunction Criteria	Threshold Value
Signal difference between two sensors	$\leq 0.77^\circ$

#### Details of Judgment Value

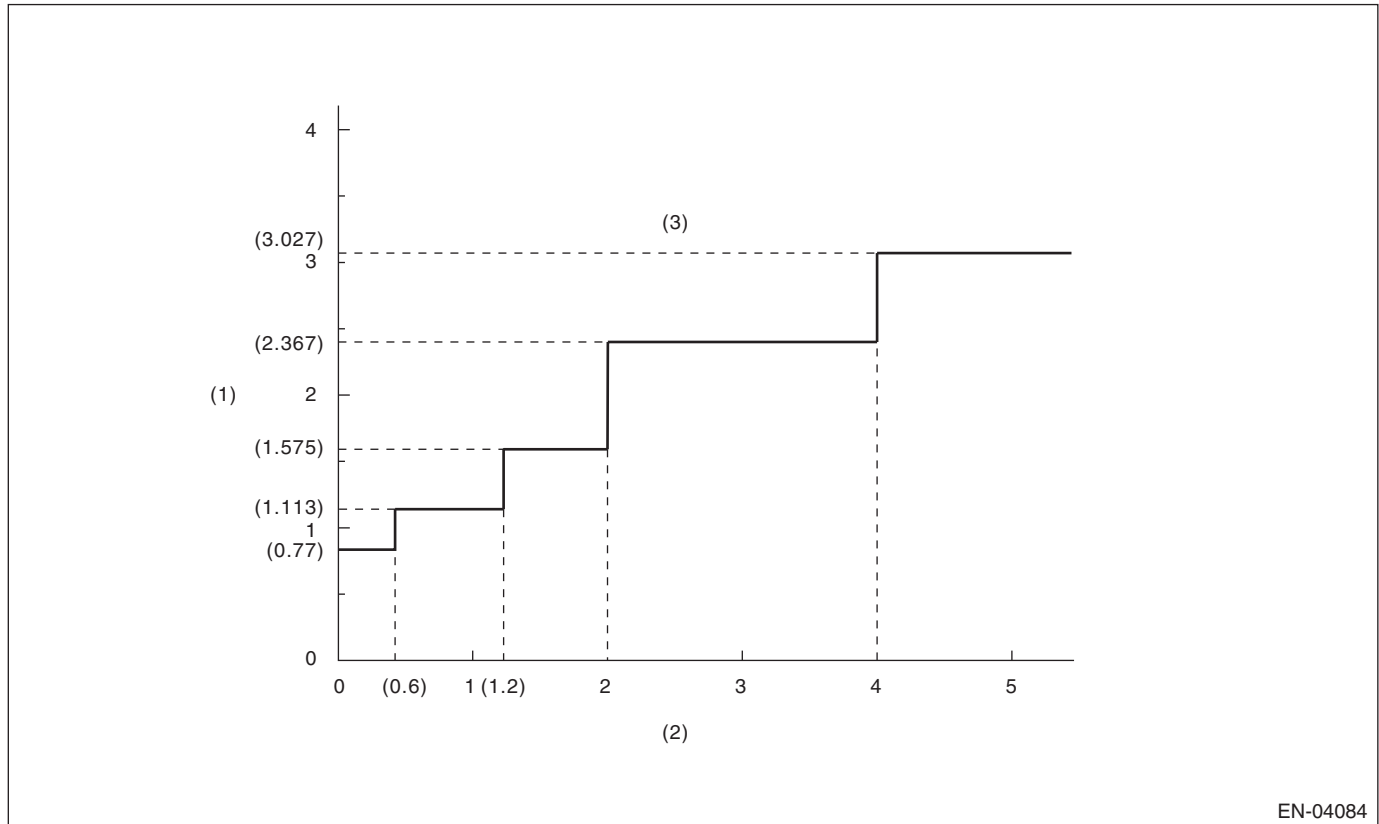

- (1) Sensor output difference
- (2) Accelerator pedal position sensor 2 opening angle (°)
- (3) NG area

#### Time Needed for Diagnosis:

- 116 milliseconds (For NG)
- 1000 milliseconds (For OK)

**Malfunction Indicator Light Illumination:** Illuminates as soon as a malfunction occurs.

### 6. DTC CLEAR CONDITION

- When the OK idling cycle is completed 40 times in a row
- When "Clear Memory" is performed

### 7. MALFUNCTION INDICATOR LIGHT CLEAR CONDITION

- When the OK driving cycle is completed 3 times in a row
- When "Clear Memory" is performed

### 8. FAIL SAFE

Throttle opening is fixed to 6°.

### 9. ECM OPERATION AT DTC SETTING

Memorize the freeze frame data. (For test mode \$02)

# Diagnostic Trouble Code (DTC) Detecting Criteria

GENERAL DESCRIPTION

## EN:DTC P2419 EVAPORATIVE EMISSION SYSTEM SWITCHING VALVE CONTROL CIRCUIT LOW

### 1. OUTLINE OF DIAGNOSIS

Detect open or short circuit of the purge control solenoid valve 2.  
Judge as NG when the ECM output level differs from the actual terminal level.

### 2. ENABLE CONDITION

Secondary Parameters	Enable Conditions
None	

### 3. GENERAL DRIVING CYCLE

Always perform the diagnosis continuously.

### 4. DIAGNOSTIC METHOD

#### Abnormality Judgment

Judge as NG when the continuous time of meeting the malfunction criteria below becomes more than 2.5 seconds.

#### Judgment Value

Malfunction Criteria	Threshold Value
Ignition switch	ON
Battery voltage	≥ 10.9 V
After engine starting	1 second or more
Terminal output voltage when ECM outputs OFF signal	Low

**Time Needed for Diagnosis:** 2.5 seconds

**Malfunction Indicator Light Illumination:** Illuminates as soon as a malfunction occurs.

#### Normality Judgment

Judge as OK and clear the NG when all the malfunction criteria below are met.

#### Judgment Value

Malfunction Criteria	Threshold Value
Ignition switch	ON
Battery voltage	≥ 10.9 V
After engine starting	1 second or more
Terminal output voltage when ECM outputs OFF signal	High

### 5. DTC CLEAR CONDITION

- When the OK idling cycle is completed 40 times in a row
- When "Clear Memory" is performed

### 6. MALFUNCTION INDICATOR LIGHT CLEAR CONDITION

- When the OK driving cycle is completed 3 times in a row
- When "Clear Memory" is performed

### 7. FAIL SAFE

None

### 8. ECM OPERATION AT DTC SETTING

Memorize the freeze frame data. (For test mode \$02)

# Diagnostic Trouble Code (DTC) Detecting Criteria

## GENERAL DESCRIPTION

---

### EO:DTC P2420 EVAPORATIVE EMISSION SYSTEM SWITCHING VALVE CONTROL CIRCUIT HIGH

#### 1. OUTLINE OF DIAGNOSIS

Detect open or short circuit of the purge control solenoid valve 2.  
Judge as NG when the ECM output level differs from the actual terminal level.

#### 2. ENABLE CONDITION

Secondary Parameters	Enable Conditions
None	

#### 3. GENERAL DRIVING CYCLE

Always perform the diagnosis continuously.

#### 4. DIAGNOSTIC METHOD

##### Abnormality Judgment

Judge as NG when the continuous time of meeting the malfunction criteria below becomes more than 2.5 seconds.

##### Judgment Value

Malfunction Criteria	Threshold Value
Ignition switch	ON
Battery voltage	$\geq 10.9$ V
After engine starting	1 second or more
Terminal output voltage when ECM outputs ON signal	High

**Time Needed for Diagnosis:** 2.5 seconds

**Malfunction Indicator Light Illumination:** Illuminates as soon as a malfunction occurs.

##### Normality Judgment

Judge as OK and clear the NG when all the malfunction criteria below are met.

##### Judgment Value

Malfunction Criteria	Threshold Value
Ignition switch	ON
Battery voltage	$\geq 10.9$ V
After engine starting	1 second or more
Terminal output voltage when ECM outputs ON signal	Low

#### 5. DTC CLEAR CONDITION

- When the OK idling cycle is completed 40 times in a row
- When "Clear Memory" is performed

#### 6. MALFUNCTION INDICATOR LIGHT CLEAR CONDITION

- When the OK driving cycle is completed 3 times in a row
- When "Clear Memory" is performed

#### 7. FAIL SAFE

None

#### 8. ECM OPERATION AT DTC SETTING

Memorize the freeze frame data. (For test mode \$02)

# Diagnostic Trouble Code (DTC) Detecting Criteria

GENERAL DESCRIPTION

## EP:DTC P2431 SECONDARY AIR INJECTION SYSTEM AIR FLOW /PRESSURE SENSOR CIRCUIT RANGE/PERFORMANCE

### 1. OUTLINE OF DIAGNOSIS

Detect malfunction in the secondary air pressure sensor output properties.

Judge as NG when the secondary air pressure sensor output is largely different from the intake manifold pressure at engine start.

### 2. ENABLE CONDITION

Secondary Parameters	Enable Conditions
Engine speed at startup	< 300 rpm
Vehicle speed	< 1 km/h
After secondary air injection system stop	3 seconds or more

### 3. GENERAL DRIVING CYCLE

Perform the diagnosis with the ignition switch ON.

### 4. DIAGNOSTIC METHOD

#### Abnormality Judgment

Judge as NG if the continuous time with the following conditions established is more than 0.3 seconds.

#### Judgment Value

Malfunction Criteria	Threshold Value
Secondary air supply piping pressure – Intake manifold pressure	≥ 200 mmHg
Intake manifold pressure at engine start-up – Intake manifold pressure	< 10 mmHg

**Time Needed for Diagnosis:** 0.3 seconds

**Malfunction Indicator Light Illumination:** Illuminates when malfunction occurs in 2 continuous driving cycles.

#### Normality Judgment

Judge as OK and clear the NG when the continuous time when the following conditions are established are more than 0.26 seconds.

#### Judgment Value

Malfunction Criteria	Threshold Value
Secondary air supply piping pressure – Intake manifold pressure	< 200 mmHg

### 5. DTC CLEAR CONDITION

- When the OK idling cycle is completed 40 times in a row
- When “Clear Memory” is performed

### 6. MALFUNCTION INDICATOR LIGHT CLEAR CONDITION

- When the OK driving cycle is completed 3 times in a row
- When “Clear Memory” is performed

### 7. FAIL SAFE

None

### 8. ECM OPERATION AT DTC SETTING

Memorize the freeze frame data. (For test mode \$02)

# Diagnostic Trouble Code (DTC) Detecting Criteria

## GENERAL DESCRIPTION

---

### **EQ:DTC P2432 SECONDARY AIR INJECTION SYSTEM AIR FLOW /PRESSURE SENSOR CIRCUIT LOW**

#### **1. OUTLINE OF DIAGNOSIS**

Judge as NG if it is out of specification.

#### **2. ENABLE CONDITION**

Secondary Parameters	Enable Conditions
None	

#### **3. GENERAL DRIVING CYCLE**

Always perform the diagnosis continuously.

#### **4. DIAGNOSTIC METHOD**

##### **Abnormality Judgment**

Judge as NG if the continuous time with the following conditions established is more than 0.5 seconds.

##### **Judgment Value**

Malfunction Criteria	Threshold Value
Ignition switch	ON
Output voltage	< 0.568 V

**Time Needed for Diagnosis:** 0.5 seconds

**Malfunction Indicator Light Illumination:** Illuminates as soon as a malfunction occurs.

##### **Normality Judgment**

Judge as OK when the following conditions are established, and clear the NG.

##### **Judgment Value**

Malfunction Criteria	Threshold Value
Ignition switch	ON
Output voltage	≥ 0.568 V

#### **5. DTC CLEAR CONDITION**

- When the OK idling cycle is completed 40 times in a row
- When "Clear Memory" is performed

#### **6. MALFUNCTION INDICATOR LIGHT CLEAR CONDITION**

- When the OK driving cycle is completed 3 times in a row
- When "Clear Memory" is performed

#### **7. FAIL SAFE**

None

#### **8. ECM OPERATION AT DTC SETTING**

Memorize the freeze frame data. (For test mode \$02)



# Diagnostic Trouble Code (DTC) Detecting Criteria

GENERAL DESCRIPTION

## ER:DTC P2433 SECONDARY AIR INJECTION SYSTEM AIR FLOW /PRESSURE SENSOR CIRCUIT HIGH

### 1. OUTLINE OF DIAGNOSIS

Judge as NG if it is out of specification.

### 2. ENABLE CONDITION

Secondary Parameters	Enable Conditions
None	

### 3. GENERAL DRIVING CYCLE

Always perform the diagnosis continuously.

### 4. DIAGNOSTIC METHOD

#### Abnormality Judgment

Judge as NG if the continuous time with the following conditions established is more than 0.5 seconds.

#### Judgment Value

Malfunction Criteria	Threshold Value
Ignition switch	ON
Output voltage	$\geq 4.921$ V

**Time Needed for Diagnosis:** 0.5 seconds

**Malfunction Indicator Light Illumination:** Illuminates as soon as a malfunction occurs.

#### Normality Judgment

Judge as OK when the following conditions are established, and clear the NG.

#### Judgment Value

Malfunction Criteria	Threshold Value
Ignition switch	ON
Output voltage	$< 4.921$ V

### 5. DTC CLEAR CONDITION

- When the OK idling cycle is completed 40 times in a row
- When "Clear Memory" is performed

### 6. MALFUNCTION INDICATOR LIGHT CLEAR CONDITION

- When the OK driving cycle is completed 3 times in a row
- When "Clear Memory" is performed

### 7. FAIL SAFE

None

### 8. ECM OPERATION AT DTC SETTING

Memorize the freeze frame data. (For test mode \$02)

## Diagnostic Trouble Code (DTC) Detecting Criteria

### GENERAL DESCRIPTION

---

#### **ES:DTC P2440 SECONDARY AIR INJECTION SYSTEM SWITCHING VALVE STUCK OPEN (BANK 1)**

NOTE:

For the diagnostic procedure, refer to DTC P0410. <Ref. to GD(H4DOTC)-116, DTC P0410 SECONDARY AIR INJECTION SYSTEM, Diagnostic Trouble Code (DTC) Detecting Criteria.>

#### **ET:DTC P2441 SECONDARY AIR INJECTION SYSTEM SWITCHING VALVE STUCK CLOSED (BANK 1)**

NOTE:

For the diagnostic procedure, refer to DTC P0410. <Ref. to GD(H4DOTC)-116, DTC P0410 SECONDARY AIR INJECTION SYSTEM, Diagnostic Trouble Code (DTC) Detecting Criteria.>

#### **EU:DTC P2442 SECONDARY AIR INJECTION SYSTEM SWITCHING VALVE STUCK OPEN (BANK 2)**

NOTE:

For the diagnostic procedure, refer to DTC P0410. <Ref. to GD(H4DOTC)-116, DTC P0410 SECONDARY AIR INJECTION SYSTEM, Diagnostic Trouble Code (DTC) Detecting Criteria.>

#### **EV:DTC P2443 SECONDARY AIR INJECTION SYSTEM SWITCHING VALVE STUCK CLOSED (BANK 2)**

NOTE:

For the diagnostic procedure, refer to DTC P0410. <Ref. to GD(H4DOTC)-116, DTC P0410 SECONDARY AIR INJECTION SYSTEM, Diagnostic Trouble Code (DTC) Detecting Criteria.>

# Diagnostic Trouble Code (DTC) Detecting Criteria

GENERAL DESCRIPTION

## EW:DTC P2444 SECONDARY AIR INJECTION SYSTEM PUMP STUCK ON

### 1. OUTLINE OF DIAGNOSIS

Detect functional errors (continually ON) of the secondary air pump.

When the secondary air supply piping pressure is high in comparison to the atmospheric pressure, it is judged as NG.

### 2. ENABLE CONDITION

Secondary Parameters	Enable Conditions
None	

### 3. GENERAL DRIVING CYCLE

Always perform the diagnosis continuously.

### 4. DIAGNOSTIC METHOD

When the secondary air pump is OFF, the secondary air supply pipe pressure should be atmospheric pressure. If it is higher than atmospheric pressure, judge as NG.

#### Abnormality Judgment

Judge as NG if the continuous time with all of the following conditions established is more than 5 seconds.

Malfunction Criteria	Threshold Value
Estimate ambient temperature	≥ 4.4°C (39.92°F)
Battery voltage	≥ 10.9 V
After secondary air injection system operation	0.6 seconds or more
Battery voltage	≥ 7 V
Atmospheric pressure	≥ 75.0 kPa (563 mmHg, 22.15 inHg)
Engine	In operation
After secondary air injection system stop	3 seconds or more
Secondary air supply piping pressure (Absolute pressure)	> Value from Map 22

#### Map 22

Unit: (kPa (mmHg, inHg))		Atmospheric pressure (kPa (mmHg, inHg))							
		69.3 (520, 20.47)	74.6 (560, 22.03)	80.0 (600, 23.63)	85.3 (640, 25.19)	90.6 (680, 26.76)	96.0 (720, 28.35)	101.3 (760, 29.92)	106.6 (800, 31.48)
Battery voltage (V)	10.5	78.0 (585, 23.03)	84.0 (630, 24.80)	90.0 (675, 26.58)	96.0 (720, 28.35)	102.0 (765, 30.13)	108.0 (810, 31.90)	114.0 (855, 33.67)	120.0 (900, 35.44)
	11.5	79.3 (595, 23.42)	85.4 (641, 25.22)	91.6 (687, 27.05)	97.7 (733, 28.86)	103.7 (778, 30.63)	109.8 (824, 32.43)	116.0 (870, 34.26)	122.1 (916, 36.28)
	12.5	80.8 (606, 23.86)	86.9 (652, 25.67)	93.2 (699, 27.53)	99.3 (745, 29.33)	105.6 (792, 31.19)	111.7 (838, 32.99)	118.0 (885, 34.85)	124.2 (932, 36.68)
	13.5	82.1 (616, 24.25)	88.4 (663, 26.11)	94.8 (711, 28.0)	101.0 (758, 29.83)	107.3 (805, 31.69)	113.7 (853, 33.58)	120.0 (900, 35.44)	126.2 (947, 37.27)
	14.5	83.4 (626, 24.63)	89.8 (674, 26.52)	96.2 (722, 28.41)	102.8 (771, 30.36)	109.2 (819, 32.25)	115.6 (867, 34.14)	122.0 (915, 36.03)	128.4 (963, 37.92)
	15.5	84.8 (636, 25.05)	89.8 (685, 26.52)	97.8 (734, 28.89)	104.4 (783, 30.83)	110.9 (832, 32.75)	117.4 (881, 34.67)	124.0 (930, 36.62)	130.5 (979, 38.54)

**Time Needed for Diagnosis:** 5 seconds

**Malfunction Indicator Light Illumination:** Illuminates as soon as a malfunction occurs.

# Diagnostic Trouble Code (DTC) Detecting Criteria

## GENERAL DESCRIPTION

---

### Normality Judgment

Judge as OK if the continuous time with all of the following conditions established is more than 5 seconds, and clear the NG.

### Judgment Value

Malfunction Criteria	Threshold Value
Estimate ambient temperature	$\geq 4.4^{\circ}\text{C}$ (39.92°F)
Battery voltage	$\geq 10.9\text{ V}$
After secondary air injection system operation	0.6 seconds or more
Battery voltage	$\geq 7\text{ V}$
Atmospheric pressure	$\geq 75.0\text{ kPa}$ (563 mmHg, 22.15 inHg)
Engine	In operation
After secondary air injection system stop	3 seconds or more
Secondary air supply piping pressure (Absolute pressure)	$\leq$ Value from Map 22

### 5. DTC CLEAR CONDITION

- When the OK idling cycle is completed 40 times in a row
- When "Clear Memory" is performed

### 6. MALFUNCTION INDICATOR LIGHT CLEAR CONDITION

- When the OK driving cycle is completed 3 times in a row
- When "Clear Memory" is performed

### 7. FAIL SAFE

None

### 8. ECM OPERATION AT DTC SETTING

Memorize the freeze frame data. (For test mode \$02)