

## 6. Intercooler

### A: REMOVAL

- 1) Remove the collector cover.
- 2) Disconnect the PCV hose from PCV pipe.

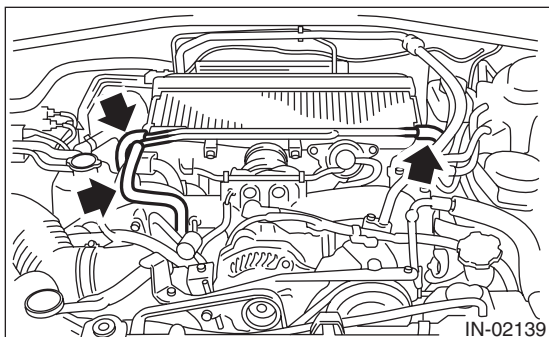

- 3) Remove the air by-pass valve from intercooler.

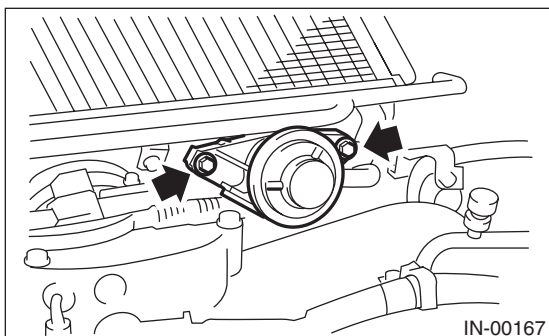

- 4) Remove the bolts which secure the intercooler to the bracket.

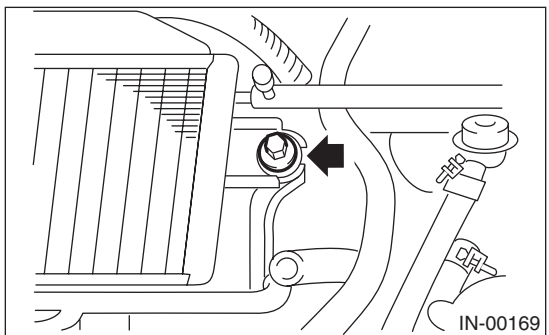
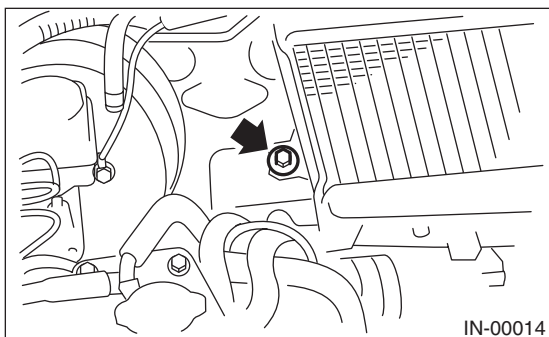

- 5) Loosen the clamps (A) which connect the turbocharger and intercooler duct.

- 6) Loosen the clamps (B) which connect the throttle body and intercooler.

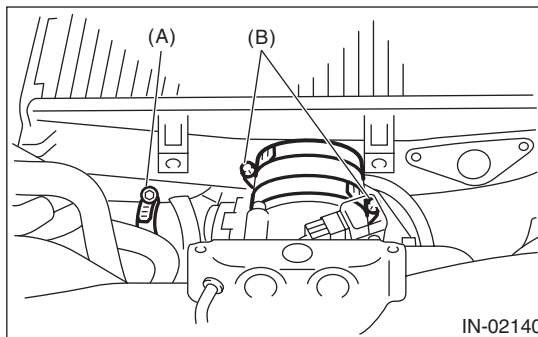

- 7) Separate the intercooler duct from turbocharger.
- 8) Remove the intercooler from throttle body.

### B: INSTALLATION

Install in the reverse order of removal.

**Tightening torque:**

**16 N·m (1.6 kgf-m, 11.6 ft-lb)**

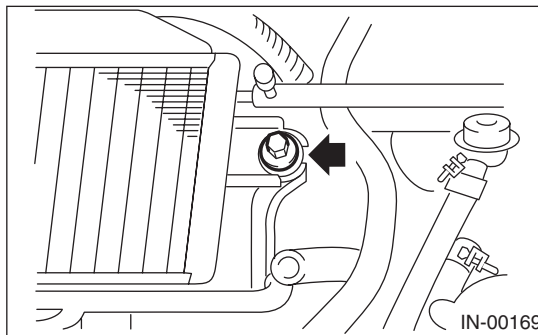
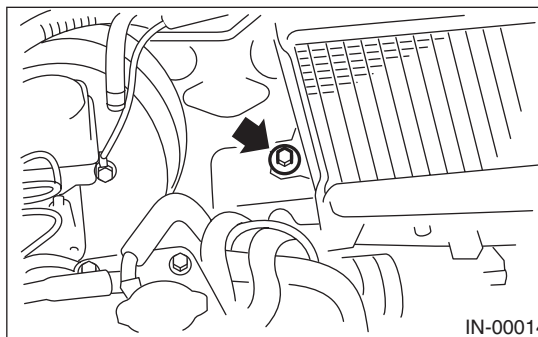

# Intercooler

## INTAKE (INDUCTION)

### C: DISASSEMBLY

- 1) Remove the air by-pass valve from intercooler.

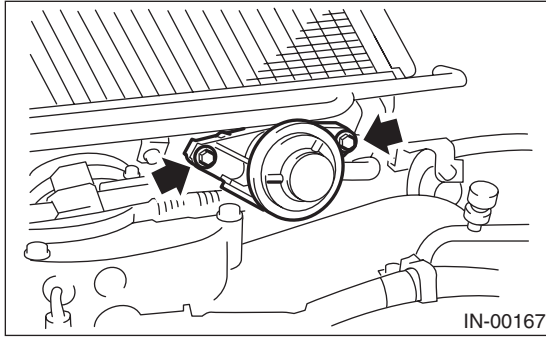

- 2) Remove the intercooler ducts from intercooler.

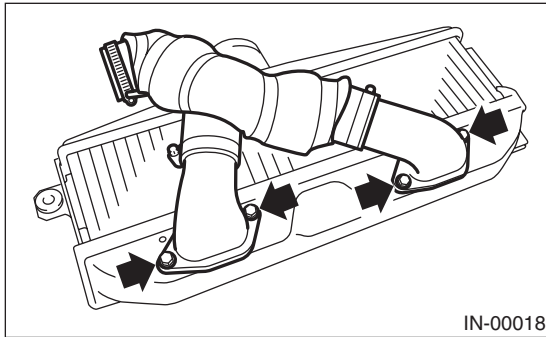

- 3) Separate the duct.

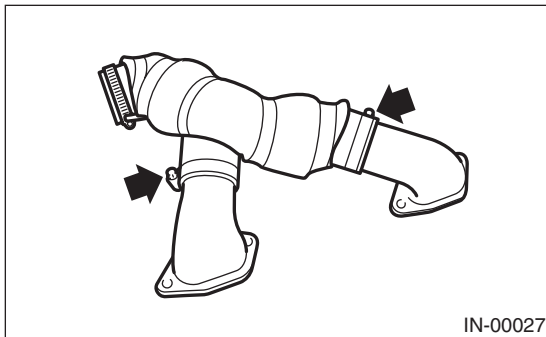

### D: ASSEMBLY

Assemble in the reverse order of disassembly.

NOTE:

Be careful not to pinch the O-ring.

**Tightening torque:**

**16 N·m (1.6 kgf-m, 11.6 ft-lb)**

