

# General Description

MECHANICAL

## 1. General Description

### A: SPECIFICATION

Engine	Model		2.5 L		
	Cylinder arrangement		Horizontally opposed, liquid cooled, 4-cylinder, 4-stroke gasoline engine		
	Valve system mechanism		Belt driven, double overhead camshaft, 4-valve/cylinder		
	Bore × Stroke		mm (in)	99.5 × 79.0 (3.92 × 3.11)	
	Piston displacement		cm <sup>3</sup> (cu in)	2,457 (149.94)	
	Compression ratio		8.4		
	Compression pressure (at 350 rpm)		kPa (kgf/cm <sup>2</sup> , psi)	981 — 1,177 (10 — 12, 142 — 171)	
	Number of piston rings		Pressure ring: 2, Oil ring: 1		
	Intake valve timing	Open	Max.retard	5° ATDC	
			Min. advance	35° BTDC	
		Close	Max.retard	65° ABDC	
			Min. advance	25° ABDC	
	Exhaust valve timing	Open		55° BBDC	
		Close		5° ATDC	
	Valve clearance	Intake	mm (in)	0.20±0.02 (0.0079±0.0008)	
		Exhaust	mm (in)	0.35±0.02 (0.0138±0.0008)	
	Idle speed [At neutral position on MT, or “P” or “N” range on AT]		rpm	No Load	MT: 700±100 AT: 700±100
A/C ON				A/C refrigerant pressure is low	MT: 725±100 AT: 750±100
			A/C refrigerant pressure is high	MT: 800±100 AT: 825±100	
Ignition order		1 → 3 → 2 → 4			
Ignition timing		BTDC/rpm	MT Model	17°±10°/700	
			AT Model	17°±10°/700	

NOTE:

OS: Oversize US: Undersize

Belt tension adjuster	Protrusion of adjuster rod		5.2 — 6.2 mm (0.204 — 0.244 in)	
Belt tensioner	Spacer O.D.		17.955 — 17.975 mm (0.7069 — 0.7077 in)	
	Tensioner bushing I.D.		18.0 — 18.08 mm (0.7087 — 0.7118 in)	
	Clearance between spacer and bushing	Standard	0.025 — 0.125 mm (0.0010 — 0.0049 in)	
		Limit	0.175 mm (0.069 in)	
	Side clearance of spacer	Standard	0.2 — 0.55 mm (0.0079 — 0.0217 in)	
Limit		0.81 mm (0.0319 in)		

# General Description

MECHANICAL

Camshaft	Bend limit			0.020 mm (0.0079 in)	
	Thrust clearance		Standard	0.068 — 0.116 mm (0.0027 — 0.0046 in)	
			Limit	0.14 mm (0.0055 in)	
	Cam lobe height		Intake	Standard	46.55 — 46.65 mm (1.833 — 1.837 in)
				Limit	46.45 mm (1.829 in)
			Exhaust	Standard	46.75 — 46.85 mm (1.841 — 1.844 in)
				Limit	46.65 mm (1.837 in)
	Camshaft journal O.D.		Standard	Front	37.946 — 37.963 mm (1.4939 — 1.4946 in)
				Center rear	29.946 — 29.963 mm (1.1790 — 1.1796 in)
	Oil clearance			Standard	0.037 — 0.072 mm (0.0015 — 0.0028 in)
Limit				0.10 mm (0.0039 in)	
Cylinder head	Surface warpage limit (Mating surface with cylinder block)			0.035 mm (0.0014 in)	
	Grinding limit			0.3 mm (0.012 in)	
	Standard height			127.5 mm (5.02 in)	
Valve seat	Seating angle			90°	
	Contacting width		Intake	Standard	0.6 — 1.4 mm (0.024 — 0.055 in)
				Limit	1.7 mm (0.067 in)
			Exhaust	Standard	1.2 — 1.8 mm (0.047 — 0.071 in)
				Limit	2.2 mm (0.087 in)
Valve guide	Inside diameter			6.000 — 6.012 mm (0.2362 — 0.2367 in)	
	Protrusion above head			15.8 — 16.2 mm (0.622 — 0.638 in)	
Valve	Head edge thickness		Intake	Standard	1.0 — 1.4 mm (0.039 — 0.055 in)
				Limit	0.8 mm (0.031 in)
			Exhaust	Standard	1.3 — 1.7 mm (0.051 — 0.067 in)
				Limit	0.8 mm (0.031 in)
	Stem outer diameter			Intake	5.955 — 5.970 mm (0.2344 — 0.2350 in)
				Exhaust	5.945 — 5.960 mm (0.2341 — 0.2346 in)
	Valve stem gap		Standard	Intake	0.030 — 0.057 mm (0.0012 — 0.0022 in)
				Exhaust	0.040 — 0.067 mm (0.0016 — 0.0026 in)
			Limit	—	0.15 mm (0.0059 in)
	Overall length			Intake	104.4 mm (4.110 in)
Exhaust				104.65 mm (4.120 in)	
Valve spring	Free length			47.32 mm (1.863 in)	
	Squareness			2.5°, 2.1 mm (0.083 in) or less	
	Tension/spring height		Set	205 — 235 N (20.9 — 24.0 kgf, 46.1 — 52.8 lb)/ 36.0 mm (1.417 in)	
			Lift	426 — 490 N (43.4 — 50.0 kgf, 95.8 — 110 lb)/ 26.50 mm (1.043 in)	
Valve lifter	Outer diameter			34.959 — 34.975 mm (1.3763 — 1.3770 in)	
	Inner diameter (cylinder head)			34.994 — 35.016 mm (1.3777 — 1.3786 in)	
	Valve lifter clearance		Standard	0.019 — 0.057 mm (0.0007 — 0.0022 in)	
			Limit	0.100 mm (0.0039 in)	

# General Description

## MECHANICAL

Cylinder block	Surface warpage limit (Mating surface with cylinder head)			0.025 mm (0.0098 in)
	Grinding limit			0.1 mm (0.004 in)
	Standard height			201.0 mm (7.91 in)
	Cylinder inner diameter	Standard	A	99.505 — 99.515 mm (3.9175 — 3.9179 in)
			B	99.495 — 99.505 mm (3.9171 — 3.9175 in)
	Taper	Standard		0.015 mm (0.0006 in)
		Limit		0.050 mm (0.0020 in)
	Out-of-roundness	Standard		0.010 mm (0.0004 in)
		Limit		0.050 mm (0.0020 in)
Piston clearance	Standard		-0.010 — 0.010 mm (-0.0004 — 0.0004 in)	
	Limit		0.030 mm (0.0012 in)	
Cylinder inner boring limit (diameter)			100.005 mm (3.9372 in)	
Piston	Outer diameter	Standard	A	99.505 — 99.515 mm (3.9175 — 3.9179 in)
			B	99.495 — 99.505 mm (3.9171 — 3.9175 in)
		0.25 mm (0.0098 in) OS		99.745 — 99.765 mm (3.9270 — 3.9278 in)
		0.50 mm (0.0197 in) OS		99.995 — 100.015 mm (3.9368 — 3.9376 in)
Piston pin	Standard clearance between piston and piston pin		Standard	0.004 — 0.008 mm (0.0002 — 0.0003 in)
			Limit	0.020 mm (0.0008 in)
	Degree of fit			Piston pin must be fitted into position with thumb at 20°C (68°F).
Piston ring	Ring closed gap	Top ring	Standard	0.20 — 0.25 mm (0.0079 — 0.0098 in)
			Limit	1.0 mm (0.039 in)
		Second ring	Standard	0.37 — 0.52 mm (0.015 — 0.020 in)
			Limit	1.0 mm (0.039 in)
	Ring groove gap	Oil ring	Standard	0.20 — 0.50 mm (0.0079 — 0.0197 in)
			Limit	1.5 mm (0.059 in)
		Top ring	Standard	0.040 — 0.080 mm (0.0016 — 0.0031 in)
			Limit	0.15 mm (0.0059 in)
Second ring	Standard	0.030 — 0.070 mm (0.0012 — 0.0028 in)		
	Limit	0.15 mm (0.0059 in)		
Connecting rod	Bend or twist per 100 mm (3.94 in) in length		Limit	0.10 mm (0.0039 in)
	Side clearance of large end		Standard	0.070 — 0.330 mm (0.0028 — 0.0130 in)
			Limit	0.4 mm (0.016 in)
Bearing of large end	Oil clearance		Standard	0.017 — 0.045 mm (0.0007 — 0.0018 in)
			Limit	0.05 mm (0.0020 in)
	Thickness at center portion		Standard	1.490 — 1.502 mm (0.0587 — 0.0591 in)
			0.03 mm (0.0012 in) US	1.504 — 1.512 mm (0.0592 — 0.0595 in)
			0.05 mm (0.0020 in) US	1.514 — 1.522 mm (0.0596 — 0.0599 in)
			0.25 mm (0.0098 in) US	1.614 — 1.622 mm (0.0635 — 0.0639 in)
Bushing of small end	Clearance between piston pin and bushing		Standard	0 — 0.022 mm (0 — 0.0009 in)
			Limit	0.030 mm (0.0012 in)

# General Description

MECHANICAL

Crankshaft	Bending limit		0.035 mm (0.0014 in)	
	Crank pin	Out-of-roundness	0.003 mm (0.0001 in)	
		Cylindricality	0.004 mm (0.0002 in)	
		Grinding limit (dia.)	To 51.750 mm (2.0374 in)	
	Crank journal	Out-of-roundness	0.005 mm (0.0002 in)	
		Cylindricality	0.006 mm (0.0002 in)	
		Grinding limit (dia.)	To 59.758 mm (2.3527 in)	
	Crank pin outer diameter	Standard	51.984 — 52.000 mm (2.0466 — 2.0472 in)	
		0.03 mm (0.0012 in) US	51.954 — 51.970 mm (2.0454 — 2.0461 in)	
		0.05 mm (0.0020 in) US	51.934 — 51.950 mm (2.0447 — 2.0453 in)	
		0.25 mm (0.0098 in) US	51.734 — 51.750 mm (2.0368 — 2.0374 in)	
	Crank journal outer diameter	Standard	59.992 — 60.008 mm (2.3619 — 2.3625 in)	
		0.03 mm (0.0012 in) US	59.962 — 59.978 mm (2.3607 — 2.3613 in)	
		0.05 mm (0.0020 in) US	59.942 — 59.958 mm (2.3599 — 2.3605 in)	
		0.25 mm (0.0098 in) US	59.742 — 59.758 mm (2.3520 — 2.3527 in)	
	Thrust clearance	Standard	0.030 — 0.115 mm (0.0012 — 0.0045 in)	
		Limit	0.25 mm (0.0098 in)	
	Oil clearance	Standard	0.010 — 0.030 mm (0.0004 — 0.0012 in)	
		Limit	0.040 mm (0.0016 in)	
	Main bearing	Thickness of main bearing	#1, #3	Standard
0.03 mm (0.0012 in) US				2.017 — 2.020 mm (0.0794 — 0.0795 in)
0.05 mm (0.0020 in) US				2.027 — 2.030 mm (0.0798 — 0.0799 in)
0.25 mm (0.0098 in) US				2.127 — 2.130 mm (0.0837 — 0.0839 in)
#2, #4, #5		Standard	2.000 — 2.013 mm (0.0787 — 0.0793 in)	
		0.03 mm (0.0012 in) US	2.019 — 2.022 mm (0.0795 — 0.0796 in)	
		0.05 mm (0.0020 in) US	2.029 — 2.032 mm (0.0799 — 0.0800 in)	
		0.25 mm (0.0098 in) US	2.129 — 2.132 mm (0.0838 — 0.0839 in)	

# General Description

MECHANICAL

## B: COMPONENT

### 1. TIMING BELT

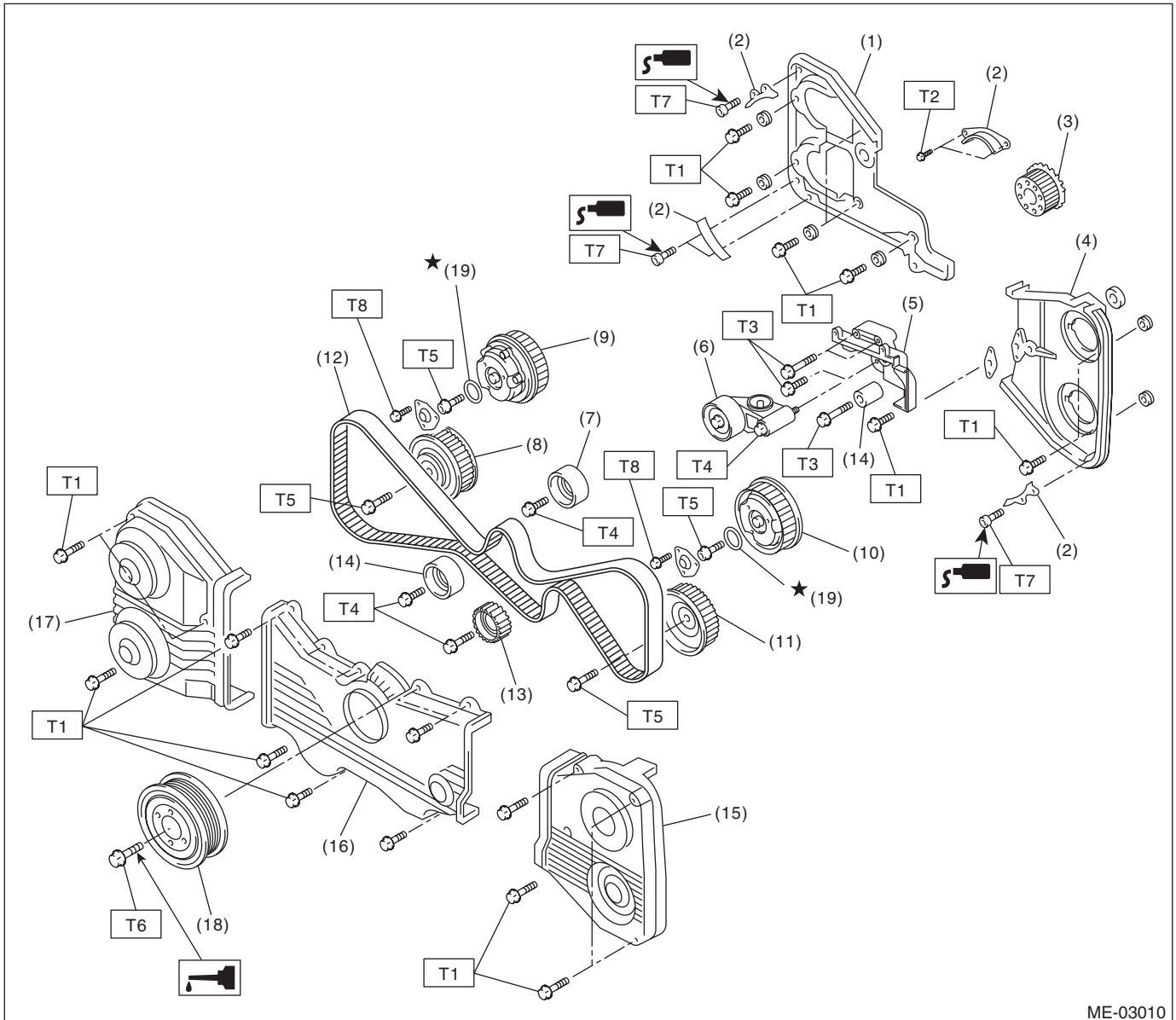

ME-03010

- |  |                                |
|--|--------------------------------|
| (1) Timing belt cover No. 2 (RH)         | (10) Intake cam sprocket (LH)  |
| (2) Timing belt guide (MT model)         | (11) Exhaust cam sprocket (LH) |
| (3) Crank sprocket                       | (12) Timing belt               |
| (4) Timing belt cover No. 2 (LH)         | (13) Belt idler No. 2          |
| (5) Tensioner bracket                    | (14) Belt idler                |
| (6) Automatic belt tension adjuster ASSY | (15) Timing belt cover (LH)    |
| (7) Belt idler                           | (16) Front belt cover          |
| (8) Exhaust cam sprocket (RH)            | (17) Timing belt cover (RH)    |
| (9) Intake cam sprocket (RH)             | (18) Crank pulley              |
|  | (19) O-ring                    |

#### **Tightening torque: N·m (kgf·m, ft·lb)**

**T1: 5 (0.5, 3.6)**

**T2: 9.75 (1.0, 7.2)**

**T3: 24.5 (2.5, 18.1)**

**T4: 39 (4.0, 28.9)**

**T5: <Ref. to ME(H4DOTC)-52, INSTALLATION, Cam Sprocket.>**

**T6: <Ref. to ME(H4DOTC)-42, INSTALLATION, Crank Pulley.>**

**T7: 6.4 (0.65, 4.7)**

**T8: 3.4 (0.35, 2.5)**

**ME(H4DOTC)-6**

## 2. CYLINDER HEAD AND CAMSHAFT

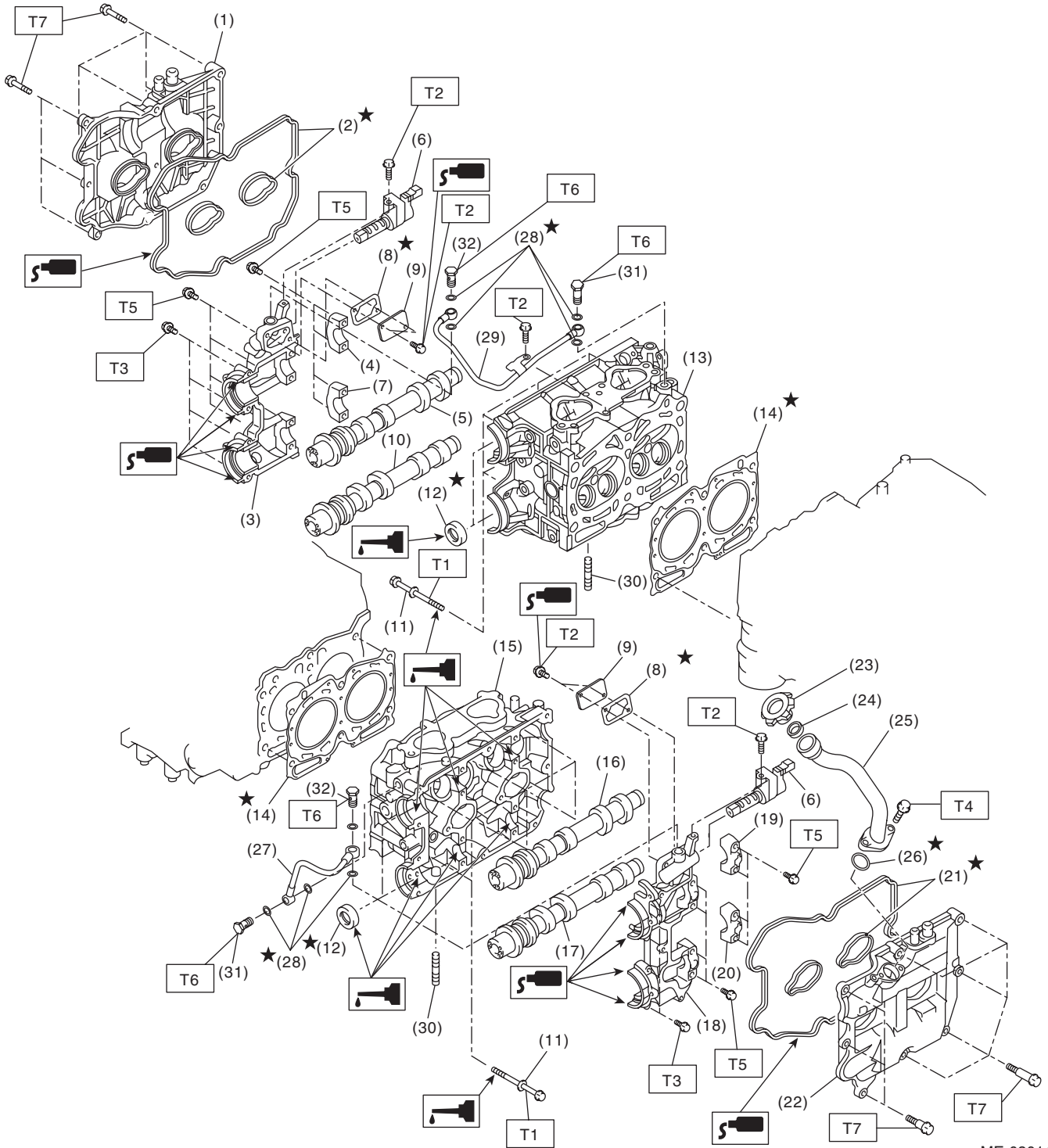

ME-03011

# General Description

## MECHANICAL

---

(1) Rocker cover (RH)	(17) Exhaust camshaft (LH)	(32) Union screw without filter (Without protrusion)
(2) Rocker cover gasket (RH)	(18) Camshaft cap (Front LH)	
(3) Camshaft cap (Front RH)	(19) Intake camshaft cap (Rear LH)	
(4) Intake camshaft cap (Rear RH)	(20) Exhaust camshaft cap (Rear LH)	<hr/>
(5) Intake camshaft (RH)	(21) Rocker cover gasket (LH)	<b>Tightening torque:N·m (kgf-m, ft-lb)</b>
(6) Oil flow control solenoid valve	(22) Rocker cover (LH)	<b>T1: &lt;Ref. to ME(H4DOTC)-60, INSTALLATION, Cylinder Head.&gt;</b>
(7) Exhaust camshaft cap (Rear RH)	(23) Oil filler cap	
(8) Gasket	(24) Gasket	<b>T2: 8 (0.8, 5.9)</b>
(9) Oil return cover	(25) Oil filler duct	<b>T3: 9.75 (1.0, 7.2)</b>
(10) Exhaust camshaft (RH)	(26) O-ring	<b>T4: 6.4 (0.65, 4.7)</b>
(11) Cylinder head bolt	(27) Oil pipe (LH)	<b>T5: 20 (2.0, 14.5)</b>
(12) Oil seal	(28) Gasket	<b>T6: 29 (3.0, 21.4)</b>
(13) Cylinder head (RH)	(29) Oil pipe (RH)	<b>T7: &lt;Ref. to ME(H4DOTC)-55, INSTALLATION, Camshaft.&gt;</b>
(14) Cylinder head gasket	(30) Stud bolt	<hr/>
(15) Cylinder head (LH)	(31) Union screw with filter (With protrusion)	
(16) Intake camshaft (LH)		

## 3. CYLINDER HEAD AND VALVE ASSEMBLY

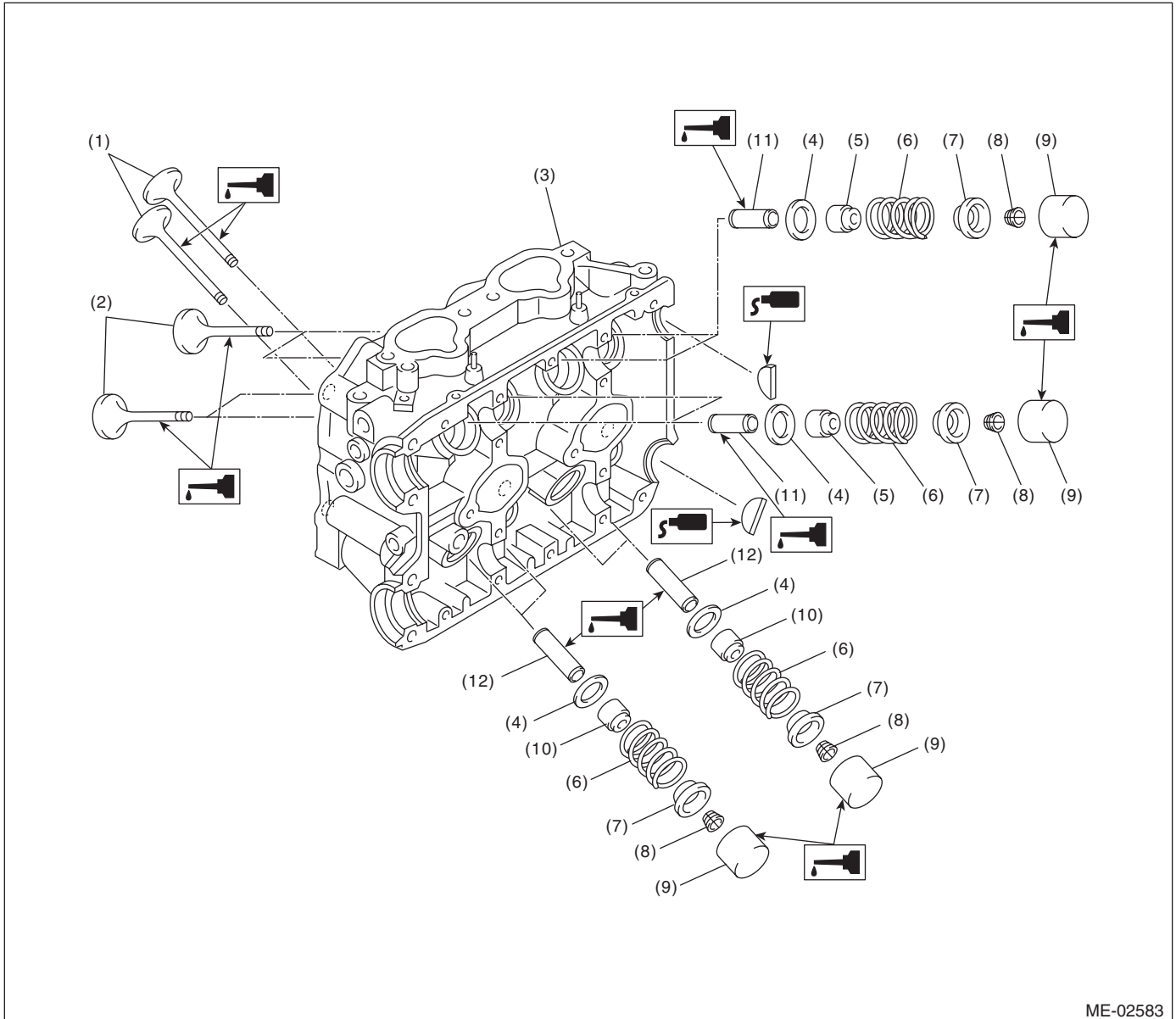

ME-02583

- |                       |                           |                             |
|-----------------------|---------------------------|-----------------------------|
| (1) Exhaust valve     | (5) Intake valve oil seal | (9) Valve lifter            |
| (2) Intake valve      | (6) Valve spring          | (10) Exhaust valve oil seal |
| (3) Cylinder head     | (7) Retainer              | (11) Intake valve guide     |
| (4) Valve spring seat | (8) Retainer key          | (12) Exhaust valve guide    |



# General Description

MECHANICAL

## 4. CYLINDER BLOCK

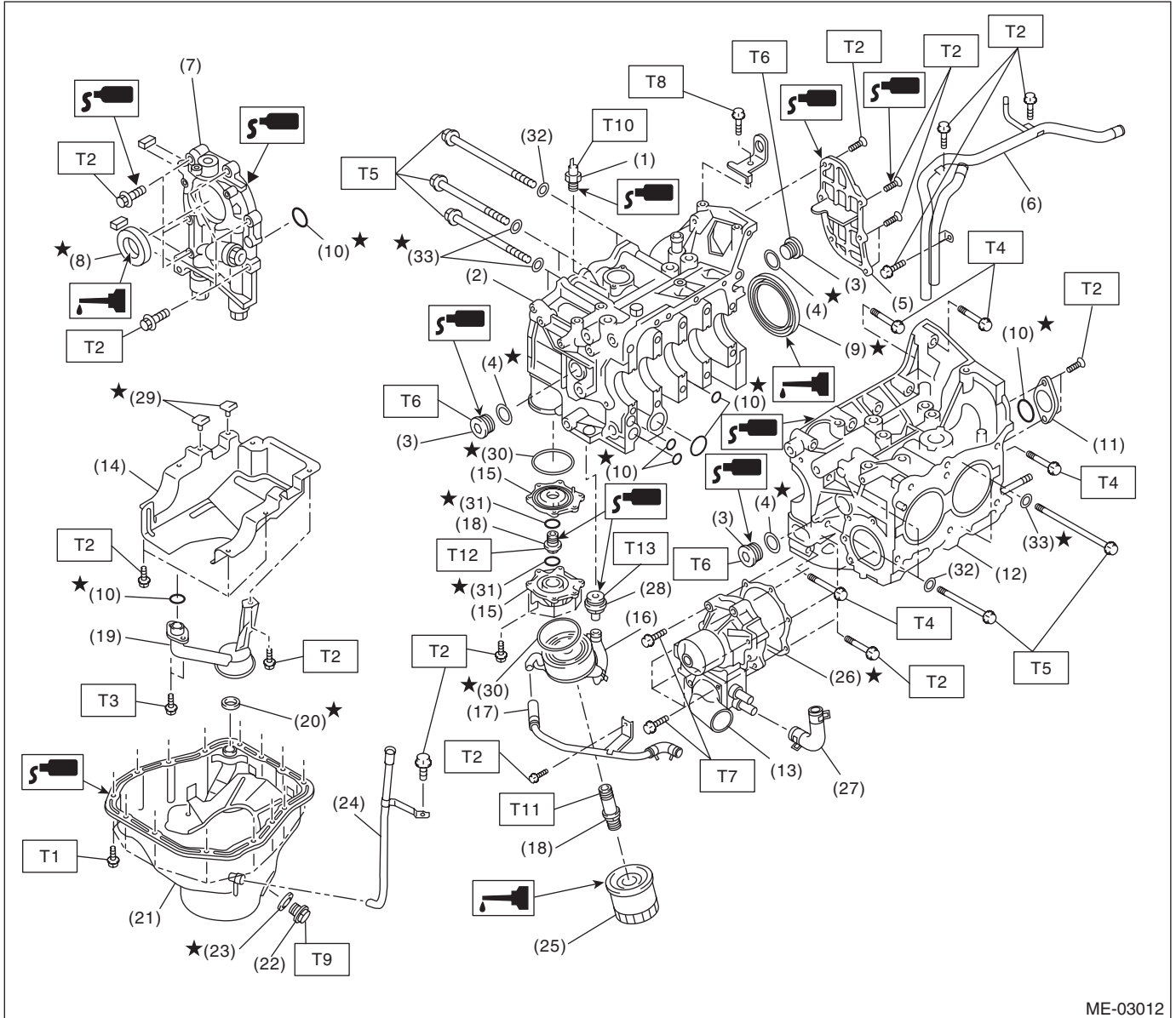

ME-03012

# General Description

MECHANICAL

---

(1) Oil pressure switch	(18) Connector	<b>Tightening torque:N·m (kgf-m, ft-lb)</b>
(2) Cylinder block (RH)	(19) Oil strainer	<b>T1: 5 (0.5, 3.6)</b>
(3) Service hole plug	(20) Gasket	<b>T2: 6.4 (0.65, 4.7)</b>
(4) Gasket	(21) Oil pan	<b>T3: 10 (1.0, 7.2)</b>
(5) Oil separator cover	(22) Drain plug	<b>T4: 25 (2.5, 18.1)</b>
(6) Water by-pass pipe	(23) Metal gasket	<b>T5: &lt;Ref. to ME(H4DOTC)-71, INSTALLATION, Cylinder Block.&gt;</b>
(7) Oil pump	(24) Oil level gauge guide	
(8) Front oil seal	(25) Oil filter	<b>T6: 70 (7.1, 50.6)</b>
(9) Rear oil seal	(26) Gasket	<b>T7: First 12 (1.2, 8.7) Second 12 (1.2, 8.7)</b>
(10) O-ring	(27) Water pump hose	
(11) Service hole cover	(28) Plug	<b>T8: 16 (1.6, 11.6)</b>
(12) Cylinder block (LH)	(29) Seal	<b>T9: 44 (4.5, 33)</b>
(13) Water pump	(30) Gasket	<b>T10: 25 (2.5, 18.1)</b>
(14) Baffle plate	(31) O-ring	<b>T11: 54 (5.3, 39)</b>
(15) Adapter	(32) Washer	<b>T12: 45 (4.6, 33)</b>
(16) Oil cooler	(33) Seal washer	<b>T13: 69 (7.0, 50.9)</b>
(17) Water by-pass pipe		

---

# General Description

MECHANICAL

## 5. CRANKSHAFT AND PISTON

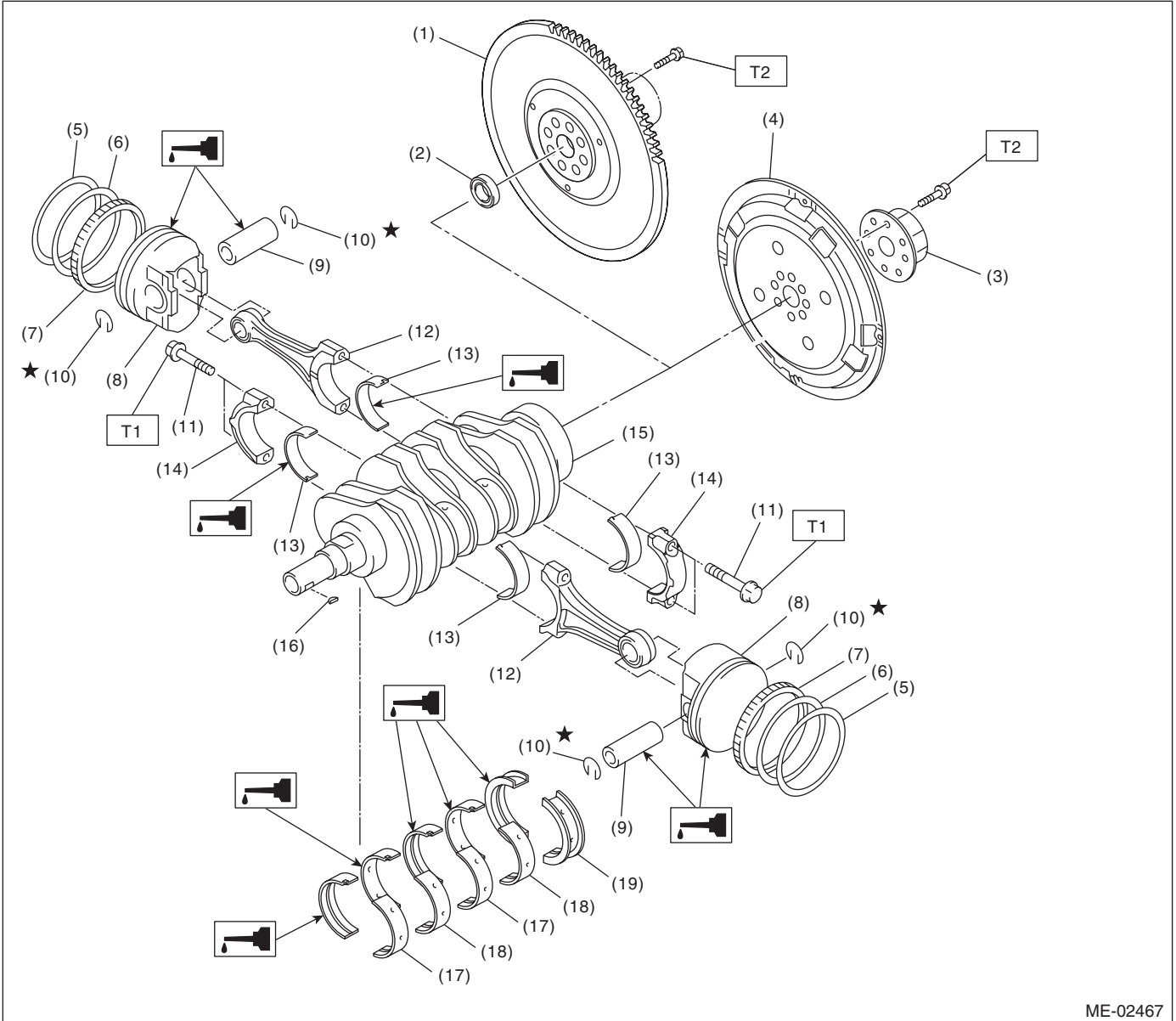

ME-02467

- |                              |                             |                                |
|------------------------------|-----------------------------|--------------------------------|
| (1) Flywheel (MT model)      | (9) Piston pin              | (17) Crankshaft bearing #1, #3 |
| (2) Ball bearing (MT model)  | (10) Snap ring              | (18) Crankshaft bearing #2, #4 |
| (3) Reinforcement (AT model) | (11) Connecting rod bolt    | (19) Crankshaft bearing #5     |
| (4) Drive plate (AT model)   | (12) Connecting rod         |                                |
| (5) Top ring                 | (13) Connecting rod bearing |                                |
| (6) Second ring              | (14) Connecting rod cap     |                                |
| (7) Oil ring                 | (15) Crankshaft             |                                |
| (8) Piston                   | (16) Woodruff key           |                                |

**Tightening torque: N·m (kgf·m, ft·lb)**

**T1: 52 (5.3, 38.4)**

**T2: 72 (7.3, 52.8)**

## 6. ENGINE MOUNTING

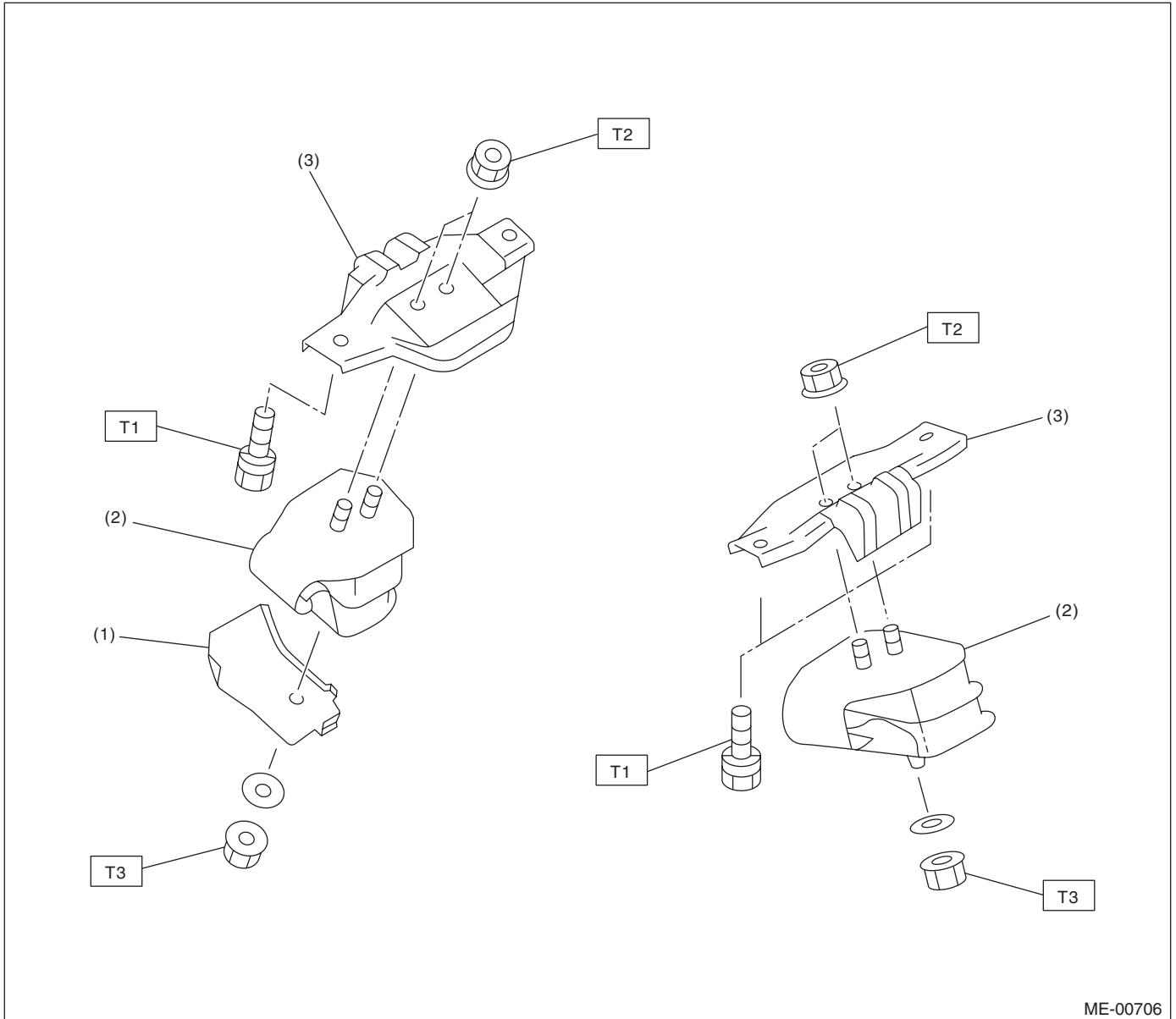

ME-00706

- (1) Heat shield cover
- (2) Front cushion rubber

- (3) Front engine mounting bracket

**Tightening torque: N·m (kgf·m, ft·lb)**

**T1: 35 (3.6, 25.8)**

**T2: 42 (4.3, 30.9)**

**T3: 85 (8.7, 62.7)**

# General Description

## MECHANICAL

---

### **C: CAUTION**

- Wear appropriate work clothing, including a cap, protective goggles and protective shoes when performing any work.
- Remove contamination including dirt and corrosion before removal, installation or disassembly.
- Keep the disassembled parts in order and protect them from dust and dirt.
- Before removal, installation or disassembly, be sure to clarify the failure. Avoid unnecessary removal, installation, disassembly and replacement.
- Vehicle components are extremely hot after driving. Be wary of receiving burns from heated parts.
- Be sure to tighten fasteners including bolts and nuts to the specified torque.
- Place shop jacks or rigid racks at the specified points.
- Before disconnecting electrical connectors of sensors or units, be sure to disconnect the ground cable from battery.
- All parts should be thoroughly cleaned, paying special attention to engine oil passages, pistons and bearings.
- Rotating parts and sliding parts such as piston, bearing and gear should be coated with oil prior to assembly.
- Be careful not to let oil, grease or coolant contact the timing belt, clutch disc and flywheel.
- All removed parts, if to be reused, should be re-installed in the original positions and directions.
- Bolts, nuts and washers should be replaced with new parts as required.
- Even if necessary inspections have been made in advance, proceed with assembly work while making rechecks.
- Remove or install the engine in an area where chain hoists, lifting devices, etc. are available for ready use.
- Be sure not to damage coated surfaces of body panels with tools or stain seats and windows with coolant or oil. Place a cover over fender, as required, for protection.
- Prior to starting work, prepare the following:  
Service tools, clean cloth, containers to catch coolant and oil, wire ropes, chain hoist, transmission jacks, etc.
- Lift-up or lower the vehicle when necessary. Make sure to support the correct positions.

## D: PREPARATION TOOL

### 1. SPECIAL TOOL

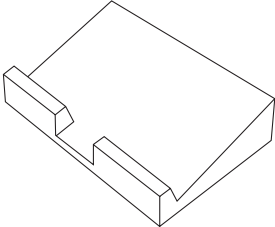
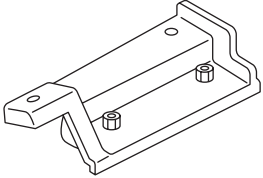
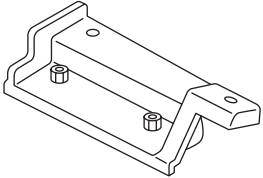
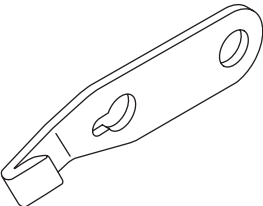
ILLUSTRATION	TOOL NUMBER	DESCRIPTION	REMARKS
 <p style="text-align: center;">ST-498267600</p>	498267600	CYLINDER HEAD TABLE	<ul style="list-style-type: none"> <li>• Used for replacing valve guides.</li> <li>• Used for removing and installing valve spring.</li> </ul>
 <p style="text-align: center;">ST-498457000</p>	498457000	ENGINE STAND ADAPTER RH	Used together with ENGINE STAND (499817100).
 <p style="text-align: center;">ST-498457100</p>	498457100	ENGINE STAND ADAPTER LH	Used together with ENGINE STAND (499817100).
 <p style="text-align: center;">ST-498497100</p>	498497100	CRANKSHAFT STOPPER	Used for removing and installing the flywheel and the drive plate.

# General Description

## MECHANICAL

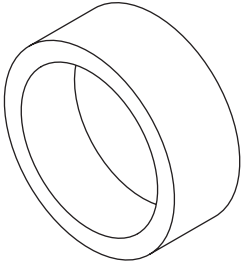
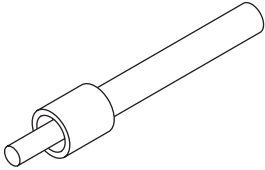
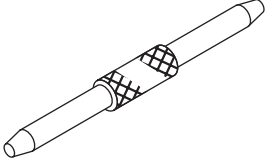
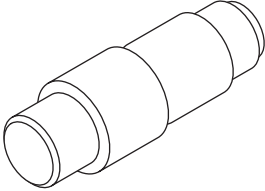
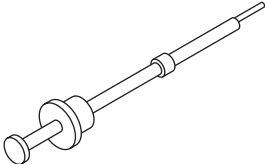
ILLUSTRATION	TOOL NUMBER	DESCRIPTION	REMARKS
 <p style="text-align: center;">ST-498747300</p>	498747300	PISTON GUIDE	Used for installing piston in cylinder. (2.5 L model)
 <p style="text-align: center;">ST-498857100</p>	498857100	VALVE OIL SEAL GUIDE	Used for press-fitting of intake and exhaust valve guide oil seals.
 <p style="text-align: center;">ST-499017100</p>	499017100	PISTON PIN GUIDE	Used for installing piston pin, piston and connecting rod.
 <p style="text-align: center;">ST-499037100</p>	499037100	CONNECTING ROD BUSHING REMOVER AND INSTALLER	Used for removing and installing connecting rod bushing.
 <p style="text-align: center;">ST-499097700</p>	499097700	PISTON PIN REMOVER ASSY	Used for removing piston pin.

# General Description

MECHANICAL

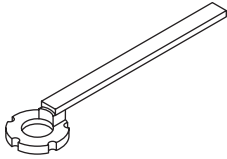
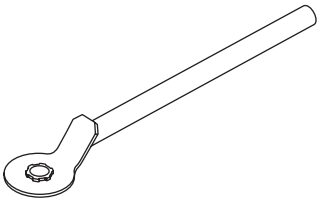
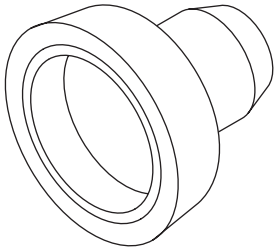
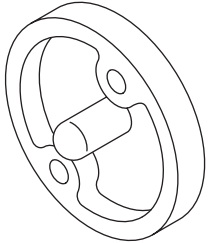
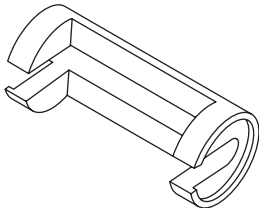
ILLUSTRATION	TOOL NUMBER	DESCRIPTION	REMARKS
 <p data-bbox="337 520 467 541">ST-499207400</p>	499207400	CAM SPROCKET WRENCH	Used for removing and installing cam sprocket. (Exhaust side)
 <p data-bbox="337 871 467 892">ST-499977500</p>	499977500	CAM SPROCKET WRENCH	Used for removing and installing cam sprocket. (Intake side)
 <p data-bbox="337 1222 467 1243">ST-499587200</p>	499587200	CRANKSHAFT OIL SEAL INSTALLER	<ul style="list-style-type: none"> <li>• Used for installing crankshaft oil seal.</li> <li>• Used together with CRANKSHAFT OIL SEAL GUIDE (499597100).</li> </ul>
 <p data-bbox="337 1572 467 1593">ST-499597100</p>	499597100	CRANKSHAFT OIL SEAL GUIDE	<ul style="list-style-type: none"> <li>• Used for installing crankshaft oil seal.</li> <li>• Used together with CRANKSHAFT OIL SEAL INSTALLER (499587200).</li> </ul>
 <p data-bbox="337 1925 467 1946">ST-499718000</p>	499718000	VALVE SPRING REMOVER	Used for removing and installing valve spring.



# General Description

## MECHANICAL

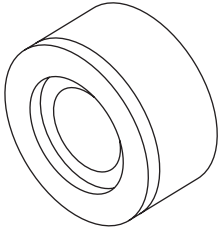
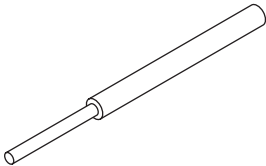
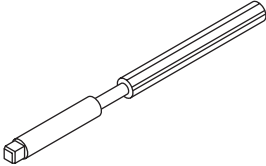
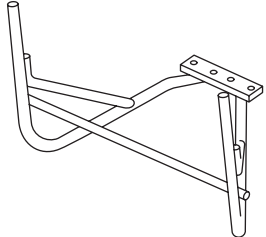
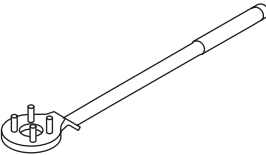
ILLUSTRATION	TOOL NUMBER	DESCRIPTION	REMARKS
 <p style="text-align: center;">ST18251AA020</p>	18251AA020	VALVE GUIDE ADJUSTER	Used for installing intake and exhaust valve guides.
 <p style="text-align: center;">ST-499767200</p>	499767200	VALVE GUIDE REMOVER	Used for removing valve guides.
 <p style="text-align: center;">ST-499767400</p>	499767400	VALVE GUIDE REAMER	Used for reaming valve guides.
 <p style="text-align: center;">ST-499817100</p>	499817100	ENGINE STAND	<ul style="list-style-type: none"> <li>• Stand used for engine disassembly and assembly.</li> <li>• Used together with ENGINE STAND ADAPTER RH (498457000) &amp; LH (498457100).</li> </ul>
 <p style="text-align: center;">ST-499977100</p>	499977100	CRANK PULLEY WRENCH	Used for stopping rotation of crank pulley when loosening/tightening crank pulley bolt.

# General Description

MECHANICAL

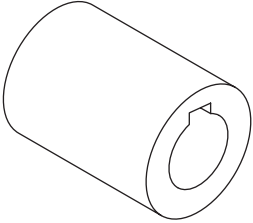
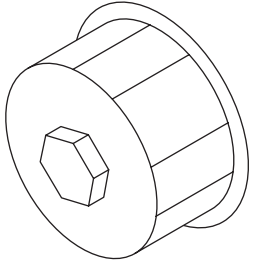
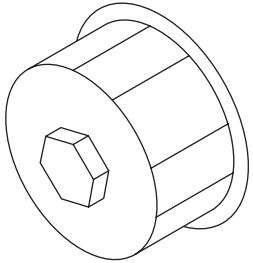
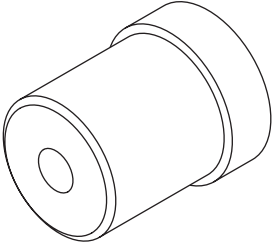
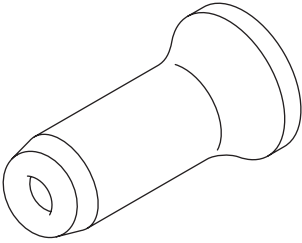
ILLUSTRATION	TOOL NUMBER	DESCRIPTION	REMARKS
 <p data-bbox="337 520 467 541">ST-499987500</p>	499987500	CRANKSHAFT SOCKET	Used for rotating crankshaft.
 <p data-bbox="326 871 467 892">ST18332AA000</p>	18332AA000	OIL FILTER WRENCH	Used for removing and installing oil filter. (Outer diameter: 68 mm (2.68 in))
 <p data-bbox="326 1222 467 1243">ST18332AA010</p>	18332AA010	OIL FILTER WRENCH	Used for removing and installing oil filter. (Outer diameter: 65 mm (2.56 in))
 <p data-bbox="337 1575 467 1596">ST-499587100</p>	499587100	OIL SEAL INSTALLER	Used for installing oil pump oil seal.
 <p data-bbox="337 1925 467 1946">ST-499587600</p>	499587600	OIL SEAL INSTALLER	Used for installing camshaft oil seal for DOHC engine.

# General Description

## MECHANICAL

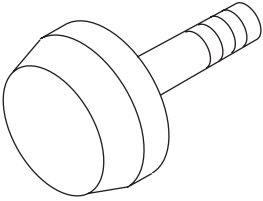
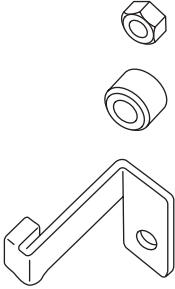
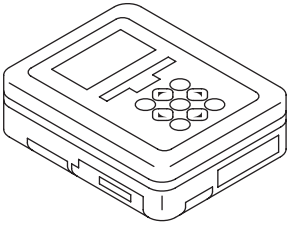
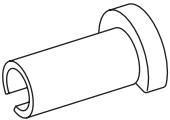
ILLUSTRATION	TOOL NUMBER	DESCRIPTION	REMARKS
 <p style="text-align: center;">ST-499597200</p>	499597200	OIL SEAL GUIDE	<ul style="list-style-type: none"> <li>Used for installing camshaft oil seal for DOHC engine.</li> <li>Used together with OIL SEAL INSTALLER (499587600).</li> </ul>
 <p style="text-align: center;">ST-498277200</p>	498277200	STOPPER SET	Used for installing automatic transmission assembly to engine.
 <p style="text-align: center;">ST1B020XU0</p>	1B020XU0	SUBARU SELECT MONITOR KIT	Used for troubleshooting the electrical system.
 <p style="text-align: center;">ST42099AE000</p>	42099AE000	CONNECTOR REMOVER	Used for removing the quick connector in engine compartment.

## 2. GENERAL TOOL

TOOL NAME	REMARKS
Compression gauge	Used for measuring compression.
Vacuum gauge	Used for measuring negative pressure.
Oil pressure gauge	Used for measuring oil pressure.
Fuel pressure gauge	Used for measuring fuel pressure.
Timing light	Used for measuring ignition timing.

## **E: PROCEDURE**

It is possible to conduct the following service procedures with engine on the vehicle, however, the procedures described in this section are based on the condition that the engine is removed from the vehicle.

- V-belt
- Timing belt
- Camshaft
- Cylinder head