

3. Engine Coolant

A: REPLACEMENT

1. DRAINING OF ENGINE COOLANT

- 1) Set the vehicle on a lift.
- 2) Lift-up the vehicle.
- 3) Remove the under cover.
- 4) Remove the drain cock to drain engine coolant into container.

NOTE:

Remove the radiator cap so that engine coolant will drain faster.

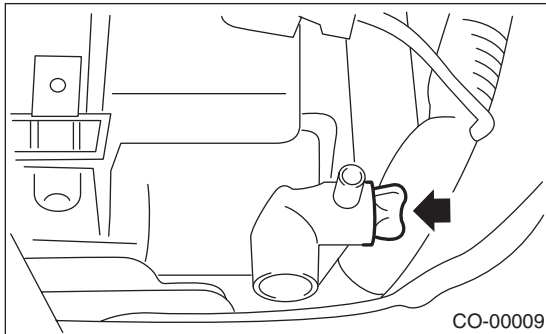

- 5) Install the drain cock.

2. FILLING OF ENGINE COOLANT

- 1) Fill cooling system conditioner into the filler neck of the radiator (the filler neck of the coolant filler tank on turbo models).

Cooling system protecting agent:

<Ref. to CO(H4SO)-2, SPECIFICATION, General Description.>

- 2) Fill engine coolant into the filler neck of the radiator (the filler neck of the coolant filler tank on turbo models) up to the filler neck position.

Recommended engine coolant:

<Ref. to CO(H4SO)-2, SPECIFICATION, General Description.>

Coolant level:

<Ref. to CO(H4SO)-2, SPECIFICATION, General Description.>

- 3) Fill engine coolant into the reservoir tank up to "FULL" level.

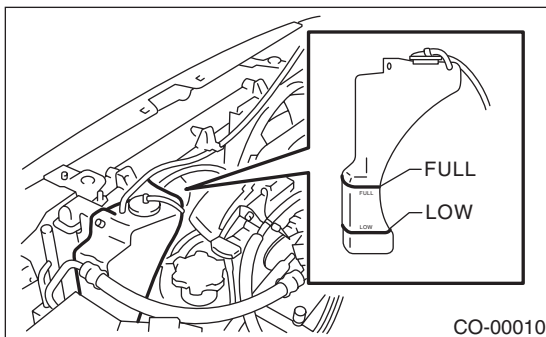

- 4) Close the radiator cap (on Non-turbo models) or the coolant filler tank cap (on turbo models), start the engine and race 5 to 6 times at less than 3,000 rpm, then stop the engine. (Complete this operation within 40 seconds.)

- 5) Wait for one minute after the engine stops, then open the radiator cap (on non-turbo models) or the coolant filler tank cap (on turbo models). If the engine coolant level drops, add engine coolant into the radiator filler neck (on non-turbo models) or the coolant filler tank filler neck (on turbo models) up to the filler neck position.

- 6) Perform the procedures 4) and 5) again.

- 7) Close the radiator cap (on non-turbo models) or the coolant filler tank cap (on turbo models), and the reservoir tank cap.

- 8) Start the engine and operate the heater at maximum hot position and the blower speed setting to "LO".

- 9) Run the engine at 2,000 rpm or less until radiator fan starts and stops.

NOTE:

Be careful with the engine coolant temperature gauge to prevent overheating.

- 10) Stop the engine and wait until the engine coolant temperature lowers to 30°C (86°F).

- 11) Open the radiator cap (on non-turbo models) or the coolant filler tank cap (on turbo models). If the engine coolant level drops, add engine coolant into the radiator filler neck (on non-turbo models) or the coolant filler tank filler neck (on turbo models) up to the filler neck position.

Then, pour the coolant into reservoir tank up to "FULL" level.

- 12) Close the radiator cap (on non-turbo models) or the coolant filler tank cap (on turbo models), and the reservoir tank cap.

- 13) Set the heater setting to maximum hot position and the blower speed setting to "LO" and start the engine. Perform racing at less than 3,000 rpm. If the flowing sound is heard at this time, perform the procedures from 9) again.

B: INSPECTION

1. RELATIONSHIP OF SUBARU COOLANT CONCENTRATION AND FREEZING TEMPERATURE

The concentration and safe operating temperature of SUBARU coolant is shown in the diagram. Measuring the temperature and specific gravity of the coolant will provide this information.

[Example]

If the coolant temperature is 25°C (77°F) and its specific gravity is 1.054, the concentration is 35% (point A), the safe operating temperature is -14°C (7°F) (point B), and the freezing temperature is -20°C (-4°F) (point C).

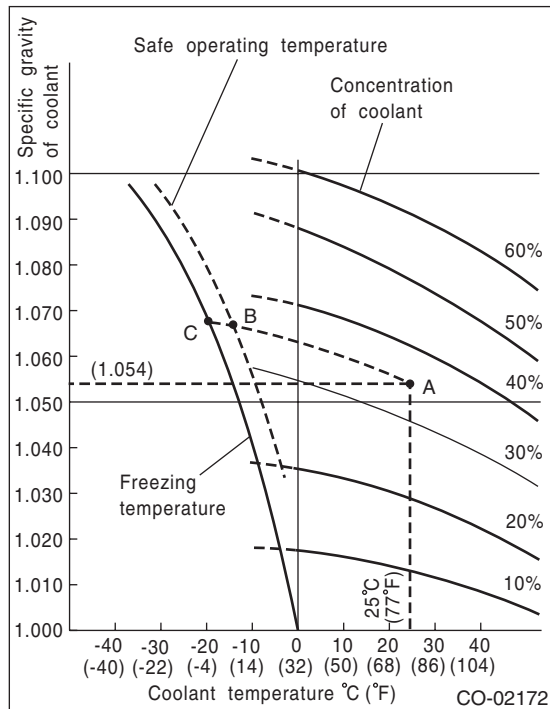

2. PROCEDURE TO ADJUST THE CONCENTRATION OF THE COOLANT

To adjust the concentration of coolant according to temperature, find the proper fluid concentration in the above diagram and replace the necessary amount of coolant with an undiluted solution of SUBARU genuine coolant (concentration 50%).

The amount of engine coolant that should be replaced can be determined using the diagram.

[Example]

Assume that the engine coolant concentration must be increased from 25% to 40%. Find point A, where the 25% line of engine coolant concentration intersects with the 40% curve of the necessary engine coolant concentration, and read the scale on the vertical axis of the graph at height A. The quantity of coolant to be drained is 2.1 ℓ (2.2 US qt, 1.8 Imp qt). Drain 2.1 ℓ (2.2 US qt, 1.8 Imp qt) of coolant from the cooling system and add 2.1 ℓ (2.2 US qt, 1.8 Imp qt) of the undiluted solution of SUBARU coolant.

If a coolant concentration of 50% is needed, drain all the coolant and refill with the undiluted solution only.

