

5. Thermostat

A: REMOVAL

- 1) Set the vehicle on a lift.
- 2) Lift-up the vehicle.
- 3) Remove the under cover.
- 4) Drain engine coolant completely. <Ref. to CO(H4SO)-18, DRAINING OF ENGINE COOLANT, REPLACEMENT, Engine Coolant.>

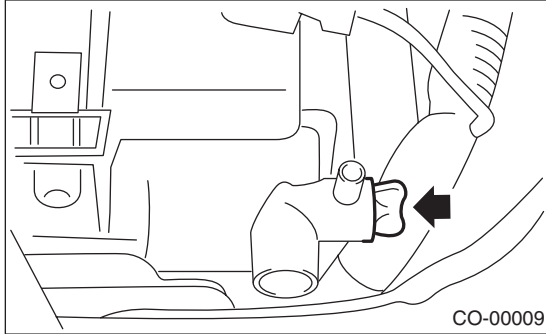

- 5) Disconnect the radiator outlet hose from thermostat cover.

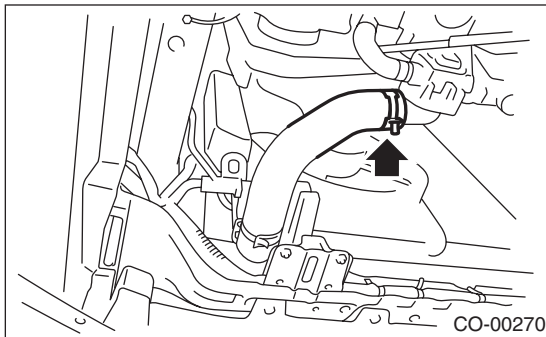

- 6) Remove the thermostat cover, and then remove the gasket and thermostat.

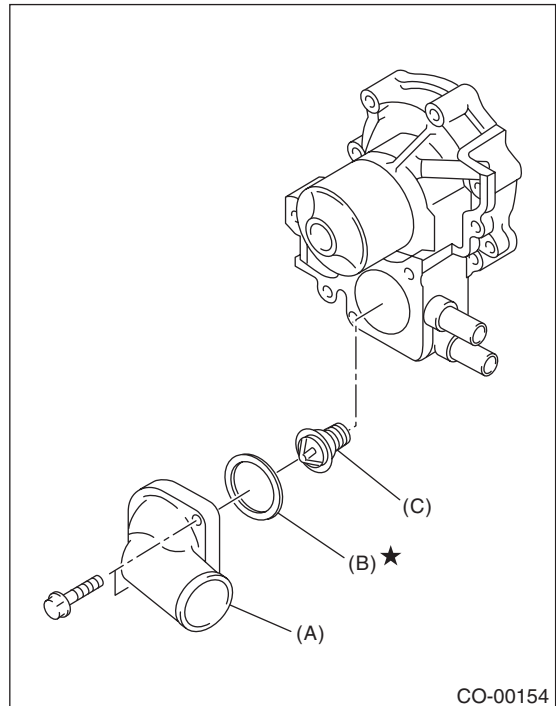

- (A) Thermostat cover
- (B) Gasket
- (C) Thermostat

Thermostat

COOLING

B: INSTALLATION

1) Install a gasket to thermostat, and install the thermostat and gasket to water pump as a unit. Then, install the thermostat cover.

NOTE:

- When reinstalling the thermostat, use a new gasket.
- The thermostat must be installed with the jiggle pin facing upward.

Tightening torque:

12 N·m (1.2 kgf-m, 8.9 ft-lb)

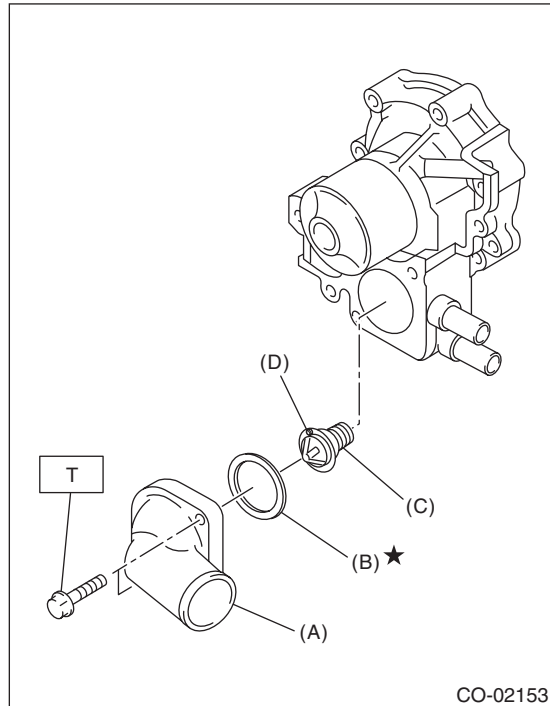

- (A) Thermostat cover
- (B) Gasket
- (C) Thermostat
- (D) Jiggle pin

2) Connect the radiator outlet hose to thermostat cover.

3) Install the under cover.

4) Lower the vehicle.

5) Fill engine coolant. <Ref. to CO(H4SO)-18, FILLING OF ENGINE COOLANT, REPLACEMENT, Engine Coolant.>

C: INSPECTION

Replace the thermostat if the valve does not close completely at an ambient temperature or if the following test shows unsatisfactory results.

• Inspection method

Immerse the thermostat and a thermometer in water. Raise water temperature gradually, and measure the temperature and valve lift when the valve begins to open and when the valve is fully opened. During the test, agitate the water for even temperature distribution. The measured value should meet the specification.

NOTE:

- Leave the thermostat in the boiling water for more than five minutes before measuring valve lift.
- Hold the thermostat with a wire or the like to avoid contacting with container bottom.

Starting temperature to open:

Non-turbo model

80 — 84°C (176 — 183°F)

Turbo model

76 — 80°C (169 — 176°F)

Fully opens:

Non-turbo model

95°C (203°F)

Turbo model

91°C (196°F)

Valve lift:

9.0 mm (0.354 in) or more

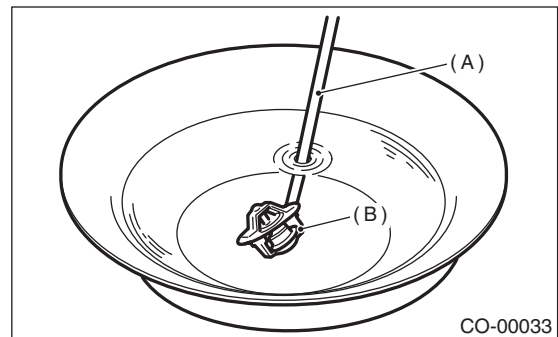

- (A) Thermometer
- (B) Thermostat