

6. Radiator

A: REMOVAL

1. NON-TURBO MODEL

WARNING:

The radiator is pressurized. Wait until engine cools down before working on the radiator.

- 1) Set the vehicle on a lift.
- 2) Disconnect the ground cable from the battery.

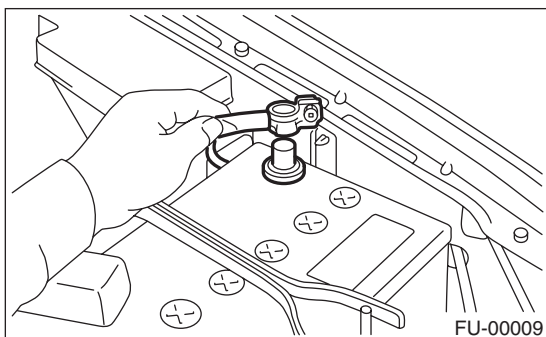

- 3) Lift-up the vehicle.
- 4) Remove the under cover.
- 5) Drain engine coolant completely. <Ref. to CO(H4SO)-18, DRAINING OF ENGINE COOLANT, REPLACEMENT, Engine Coolant.>
- 6) Disconnect the connectors of radiator main fan (A) and sub fan motor (B).

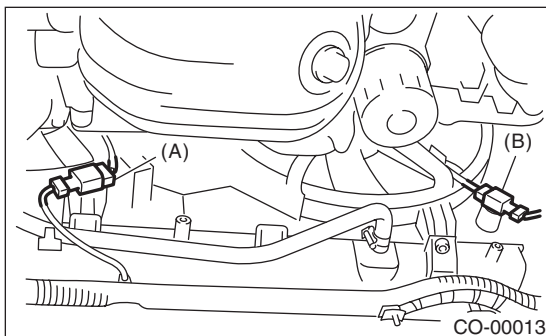

- 7) Disconnect the radiator outlet hose from thermostat cover.

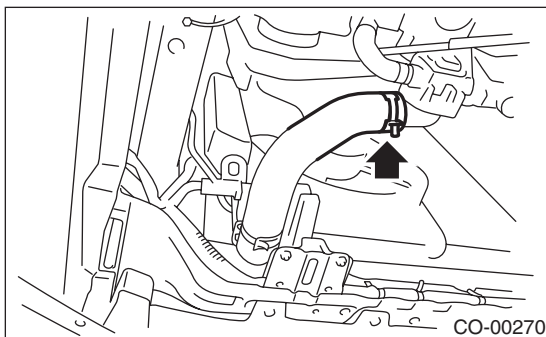

- 8) Disconnect the ATF cooler hoses from ATF pipes. (AT model) Apply the cap to prevent ATF leaks.

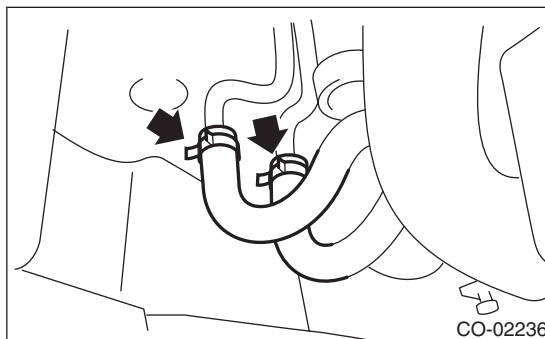

- 9) Lower the vehicle.
- 10) Disconnect the over flow hose.
- 11) Remove the reservoir tank.

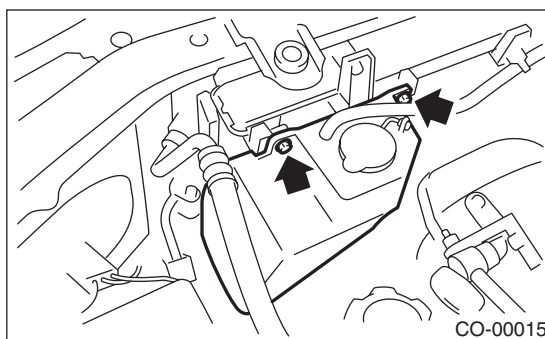

- 12) Disconnect the radiator inlet hose from radiator.

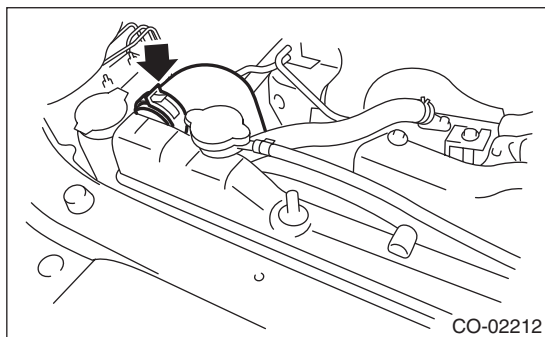

- 13) Remove the radiator upper brackets.

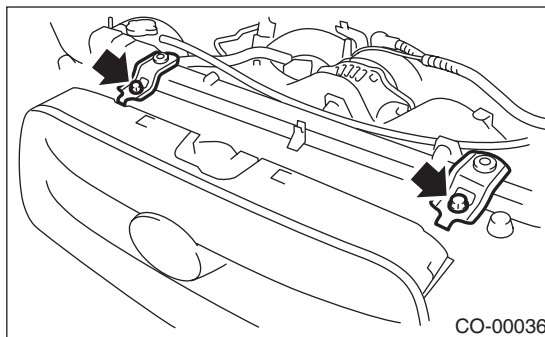

Radiator

COOLING

14) Detach the power steering hose from the clip on the radiator.

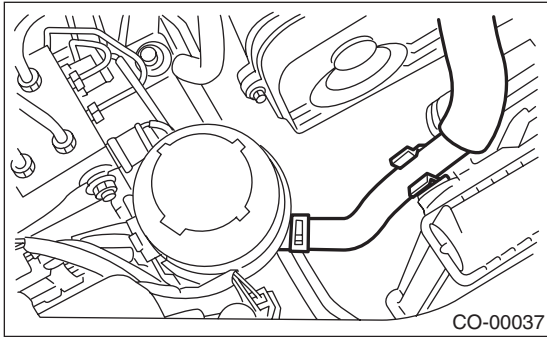

15) Lift the radiator up and away from vehicle.
16) Remove the radiator under cover. (AT model)

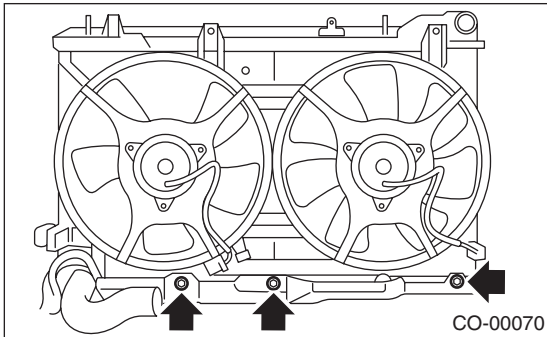

2. TURBO MODEL

WARNING:

The radiator is pressurized. Wait until engine cools down before working on the radiator.

- 1) Set the vehicle on a lift.
- 2) Remove the collector cover.
- 3) Disconnect the ground cable from the battery.

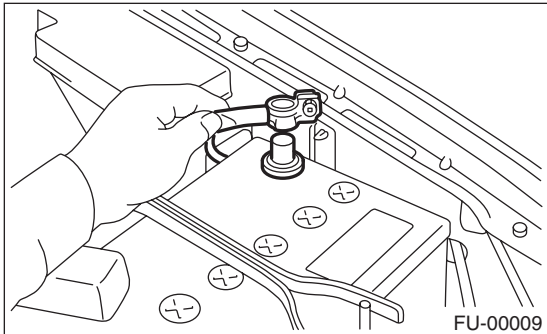

- 4) Lift-up the vehicle.
- 5) Remove the under cover.
- 6) Drain engine coolant completely. <Ref. to CO(H4SO)-18, DRAINING OF ENGINE COOLANT, REPLACEMENT, Engine Coolant.>

7) Disconnect the connectors of radiator main fan (A) and sub fan motor (B).

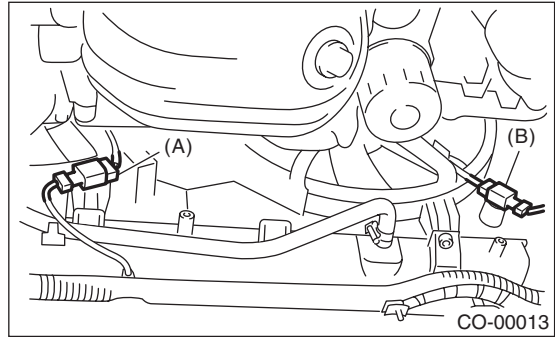

8) Disconnect the radiator outlet hose from thermostat cover.

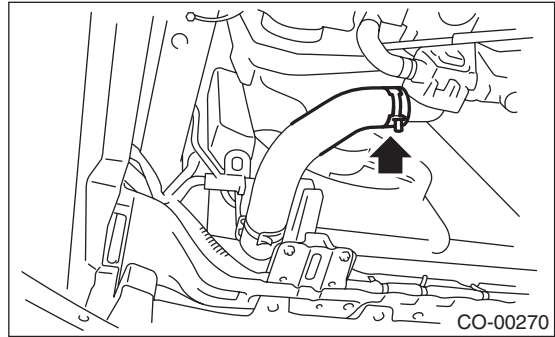

9) Disconnect the ATF cooler hoses from ATF pipes. (AT model)
Apply the cap to prevent ATF leaks.

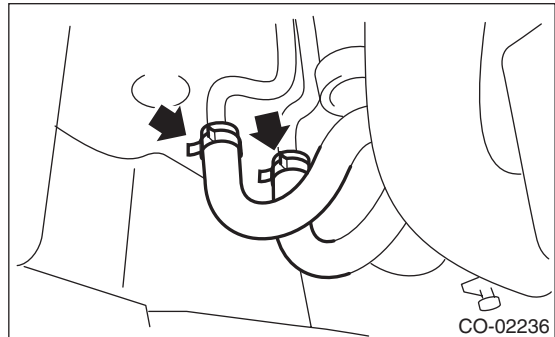

- 10) Lower the vehicle.
- 11) Remove the reservoir tank.

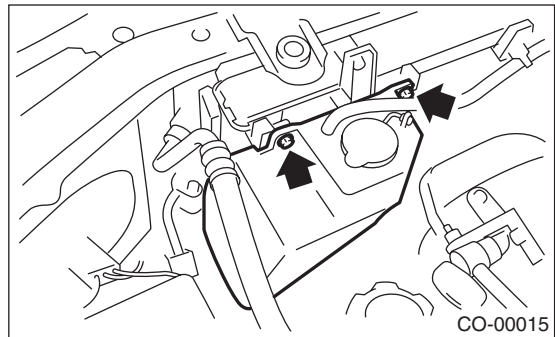

12) Disconnect the radiator inlet hose, air breather hose and the overflow hose from radiator.

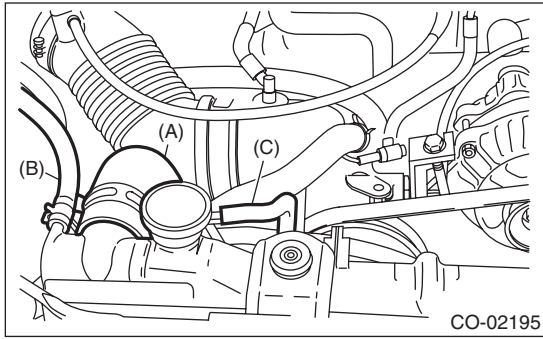

- (A) Radiator inlet hose
- (B) Air breather hose
- (C) Over flow hose

13) Remove the radiator upper brackets.

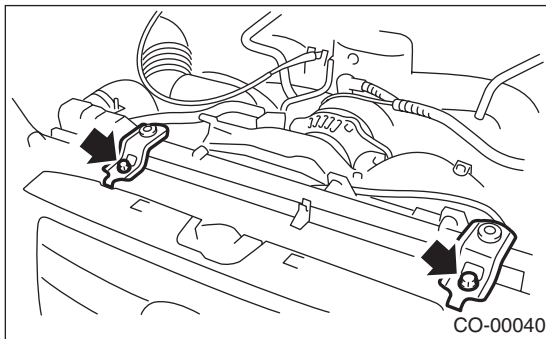

14) Disconnect the power steering hose from the clip on the radiator.

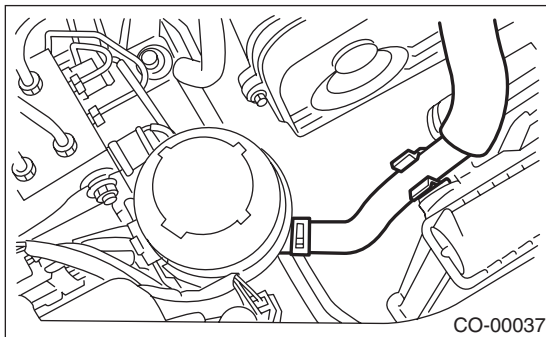

15) Lift the radiator up and away from vehicle.

16) Remove the radiator under cover. (AT model)

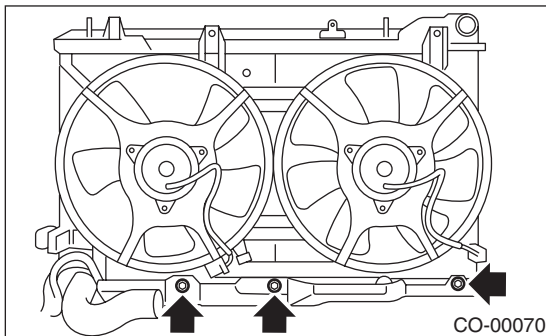

B: INSTALLATION

1. NON-TURBO MODEL

1) Attach the radiator under cover to the radiator. (AT model)

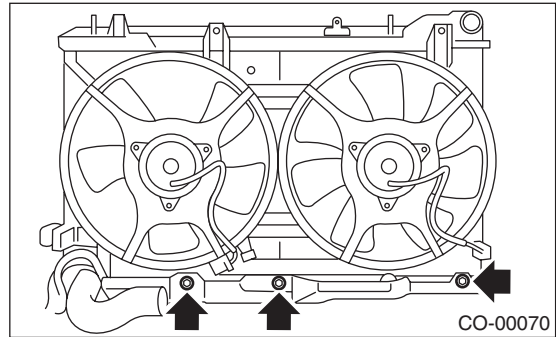

2) Attach the radiator lower cushions to holes on the vehicle.

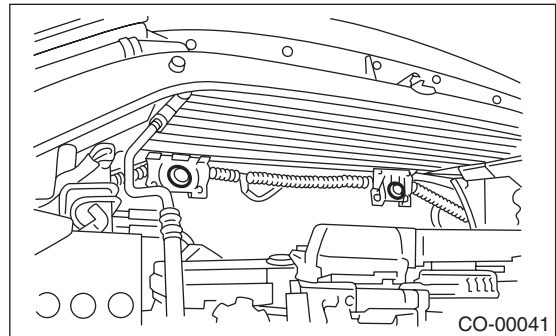

3) Install the radiator to vehicle.

NOTE:

Make pins on the lower side of radiator be fitted into the radiator lower cushions on body side.

4) Install the radiator upper brackets and tighten the bolts.

Tightening torque:

18 N·m (1.8 kgf-m, 13.0 ft-lb)

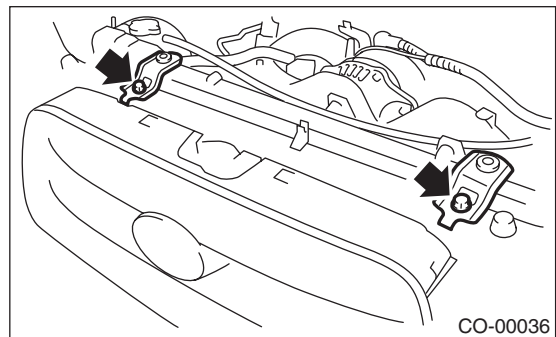

Radiator

COOLING

5) Attach the power steering hose to the radiator.

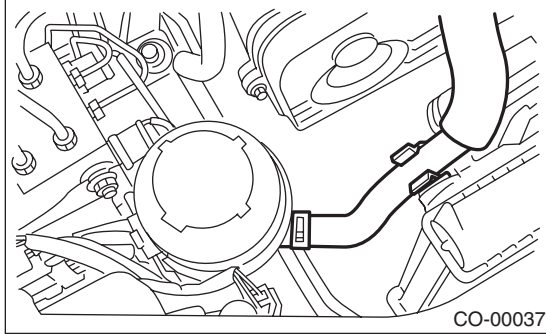

6) Connect the radiator inlet hose.

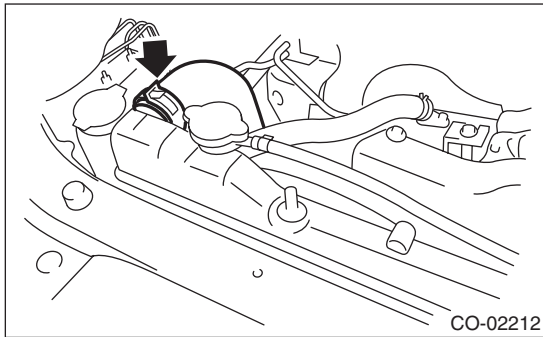

7) Install the reservoir tank.

Tightening torque:

7.5 N·m (0.76 kgf-m, 5.5 ft-lb)

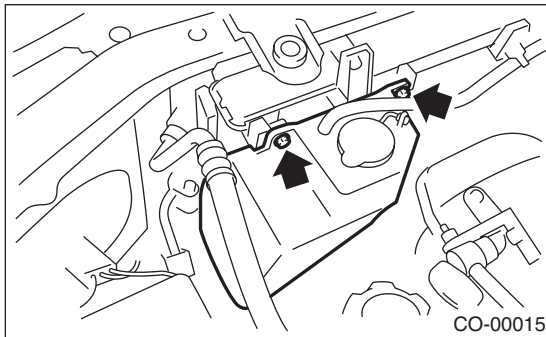

8) Connect the over flow hose.

9) Lift-up the vehicle.

10) Connect the ATF cooler hoses. (AT model)

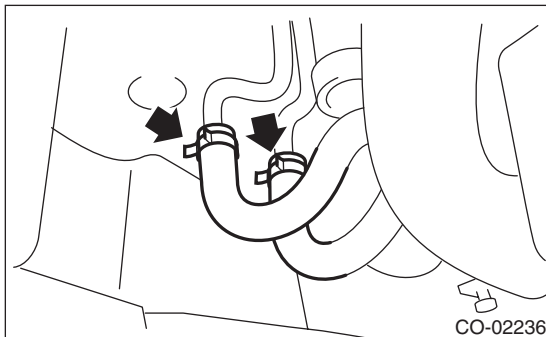

11) Connect the radiator outlet hose.

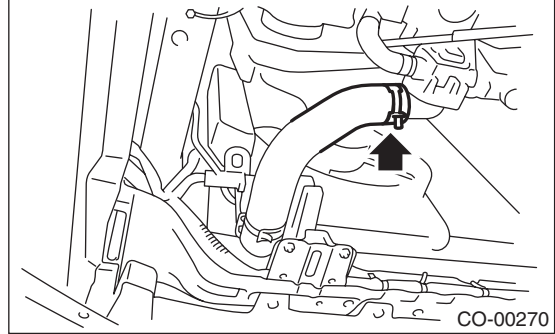

12) Connect the connectors to the radiator main fan motor (A) and sub fan motor (B).

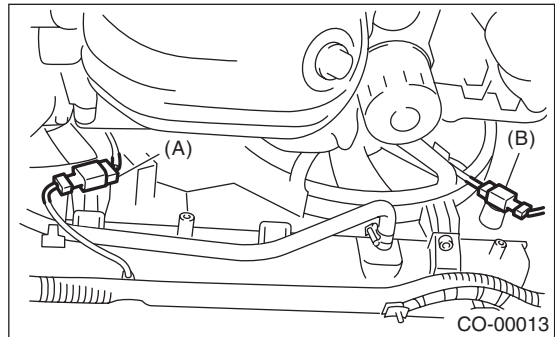

13) Install the under cover.

14) Lower the vehicle.

15) Connect the ground cable to the battery.

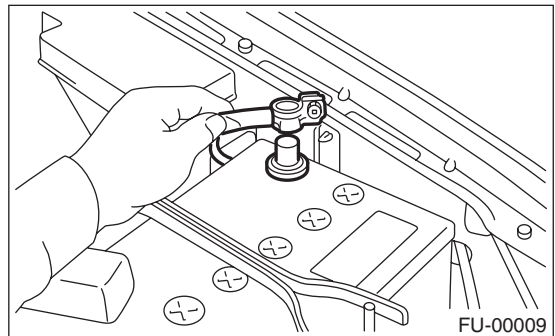

16) Fill engine coolant. <Ref. to CO(H4SO)-18, FILLING OF ENGINE COOLANT, REPLACEMENT, Engine Coolant.>

17) Check the ATF level. <Ref. to 4AT-28, INSPECTION, Automatic Transmission Fluid.>

2. TURBO MODEL

1) Attach the radiator under cover to the radiator. (AT model)

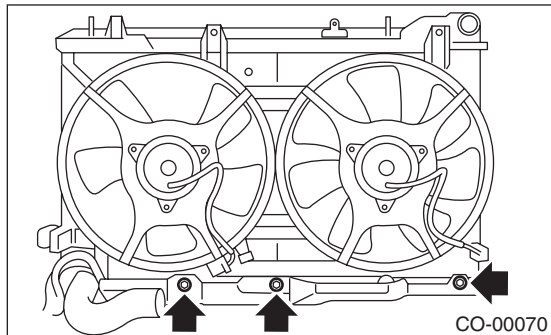

2) Attach the radiator lower cushions to holes on the vehicle.

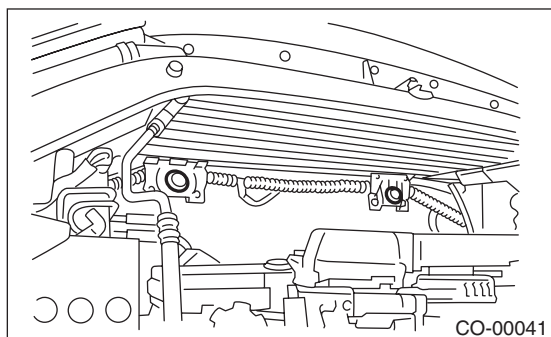

3) Install the radiator to vehicle.

NOTE:

Make pins on the lower side of radiator be fitted into the radiator lower cushions on body side.

4) Install the radiator upper brackets and tighten the bolts.

Tightening torque:

18 N·m (1.8 kgf-m, 13.0 ft-lb)

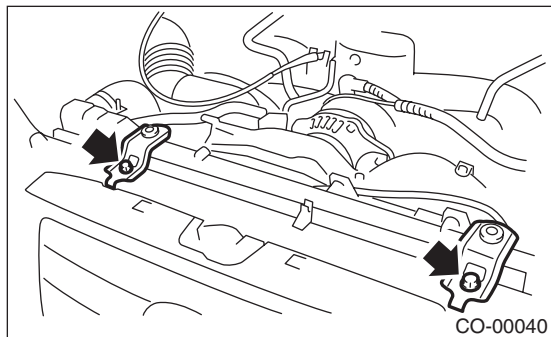

5) Attach the power steering hose to the radiator.

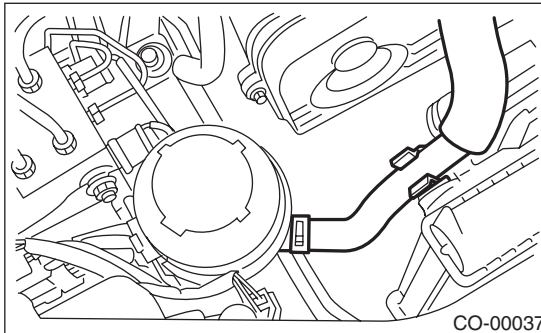

6) Connect the radiator inlet hose, air breather hose and the overflow hose (B).

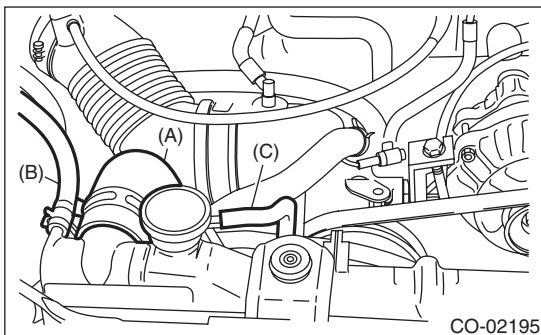

(A) Radiator inlet hose

(B) Air breather hose

(C) Over flow hose

7) Install the reservoir tank.

Tightening torque:

7.5 N·m (0.76 kgf-m, 5.5 ft-lb)

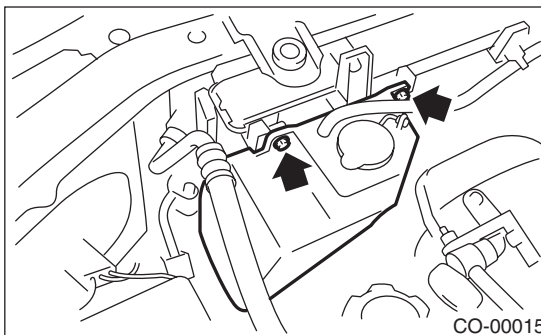

8) Lift-up the vehicle.

9) Connect the ATF cooler hoses. (AT model)

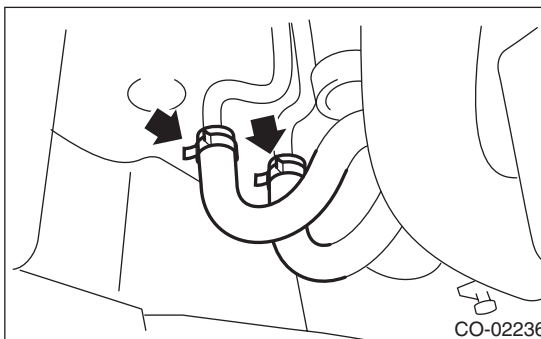

Radiator

COOLING

10) Connect the radiator outlet hose.

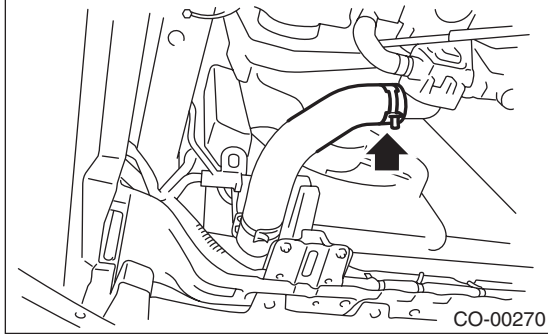

11) Connect the connectors to the radiator main fan motor (A) and sub fan motor (B).

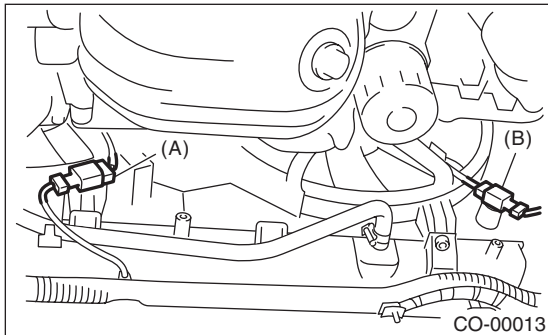

12) Install the under cover.

13) Lower the vehicle.

14) Connect the ground cable to the battery.

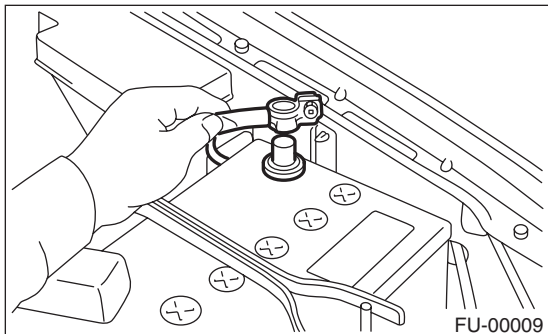

15) Fill engine coolant. <Ref. to CO(H4SO)-18, FILLING OF ENGINE COOLANT, REPLACEMENT, Engine Coolant.>

16) Check the ATF level. <Ref. to 4AT-28, INSPECTION, Automatic Transmission Fluid.>

17) Install the collector cover.

C: INSPECTION

1) Remove the radiator cap (for Non-turbo model) or the coolant filler tank cap (for turbo model), and fill the engine coolant, and then install the tester (A) to the installation position of cap.

- Non-turbo model

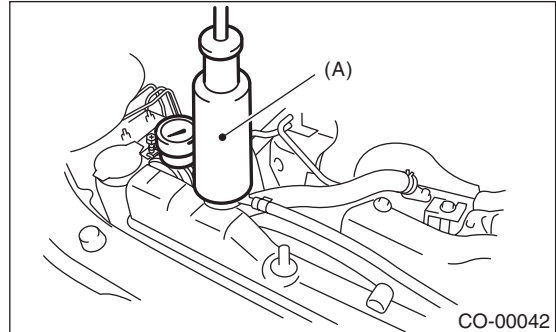

- Turbo model

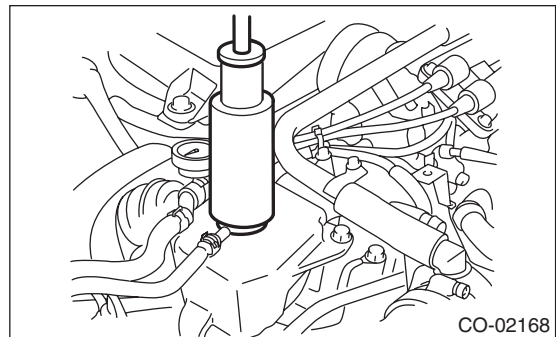

2) When engine coolant leaks at/around radiator, apply the following pressure.

Non-turbo model

157 kPa (1.6 kg/cm², 23 psi)

Turbo model

122 kPa (1.2 kg/cm², 18 psi)

CAUTION:

- Inspection must be carried out at the side of coolant filler tank, not at the side of radiator. (Turbo model)
- Engine should be turned off.
- Wipe engine coolant from check points in advance.
- Be careful to prevent engine coolant from spurting out when removing tester.
- Be careful not to deform the filler neck of radiator when installing and removing the tester.