

21. Fuel

A: PROCEDURE

1. RELEASING OF FUEL PRESSURE

WARNING:

Place “NO FIRE” signs near the working area.

CAUTION:

Be careful not to spill fuel.

- 1) Disconnect the connector from fuel pump relay.

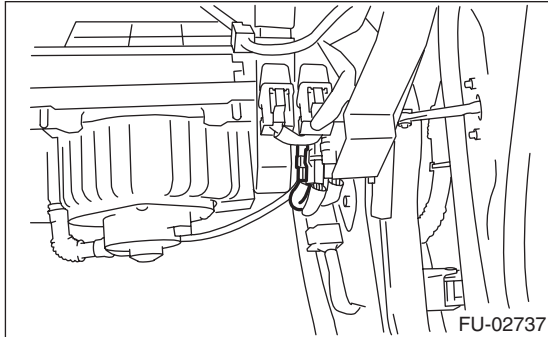

- 2) Start the engine and run it until it stalls.
- 3) After the engine stalls, crank it for five more seconds.
- 4) Turn the ignition switch to OFF.

2. DRAINING FUEL

WARNING:

Place “NO FIRE” signs near the working area.

CAUTION:

Be careful not to spill fuel.

- 1) Set the vehicle on a lift.
- 2) Disconnect the ground cable from the battery.

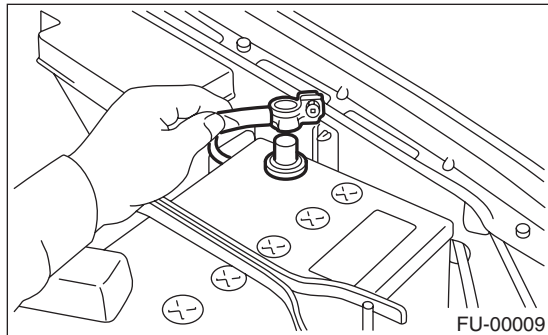

- 3) Open the fuel filler flap lid, and remove the fuel filler cap.
- 4) Lift-up the vehicle.

- 5) Drain fuel from fuel tank.

Set a container under the vehicle and remove the fuel drain plug from the fuel tank.

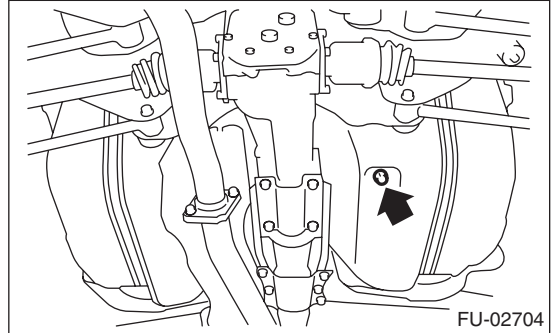

- 6) Tighten the fuel drain plugs.

NOTE:

Use a new gasket.

Tightening torque:

26 N·m (2.65 kgf·m, 19.2 ft·lb)