

Diagnostic Trouble Code (DTC) Detecting Criteria

GENERAL DESCRIPTION

2. Diagnostic Trouble Code (DTC) Detecting Criteria

A: DTC P0026 INTAKE VALVE CONTROL SOLENOID CIRCUIT RANGE/ PERFORMANCE (BANK 1)

1. OUTLINE OF DIAGNOSIS

Detect NG when having either Low NG or High NG.

A variable valve lift diagnosis oil pressure switch is installed for diagnosis. It is possible to determine whether the intake valve is in high mode (increase the amount of lift) or in low mode (suppressing the amount of lift) when the variable valve lift diagnosis oil pressure switch is turned ON or OFF.

• NORMAL

Oil switching solenoid valve duty	Intake valve	Variable valve lift diagnosis oil pressure switch
Large	High mode	ON
Small	Low mode	OFF

• Low NG

When the variable valve lift diagnosis oil pressure switch remains OFF even though the intake valve tried to enter high mode (oil switching solenoid valve duty is large), this is judged as a Low NG.

• High NG

When the variable valve lift diagnosis oil pressure switch remains ON even though the intake valve tried to enter low mode (oil switching solenoid valve duty is small), this is judged as a High NG.

2. COMPONENT DESCRIPTION

The variable valve lift system optimizes the intake valve lift by switching between the low lift cam and the high lift cam according to the engine speed. The amount of intake valve lift is varied by controlling the oil switching solenoid valve duty according to signals from the ECM.

3. ENABLE CONDITION

Secondary Parameters	Enable Conditions
Battery voltage	≥ 10.9 V
After engine starting	≥ 6 sec.
Engine oil temperature	$\geq 15^{\circ}\text{C}$ (59°F)
Variable valve lift control	Operation

4. GENERAL DRIVING CYCLE

Perform the diagnosis continuously 6 seconds after engine start while variable valve lift is being controlled.

Diagnostic Trouble Code (DTC) Detecting Criteria

GENERAL DESCRIPTION

5. DIAGNOSTIC METHOD

Abnormality Judgment

Judge as NG when the continuous time of meeting the following conditions is longer than the predetermined time.

Judgment Value

Malfunction Criteria	Threshold Value
Low NG Duty ratio Variable valve lift diagnosis oil pressure switch	≥ 62% OFF
High NG Duty ratio Variable valve lift diagnosis oil pressure switch	< 33% ON

Time Needed for Diagnosis:

Low side	0.784 seconds
High side	3.0 seconds

Malfunction Indicator Light Illumination: Illuminates as soon as a malfunction occurs.

Normality Judgment

Judge as OK and clear the NG when the continuous time when the following conditions are established are more than 3 seconds.

Judgment Value

Malfunction Criteria	Threshold Value
Low OK Duty ratio Variable valve lift diagnosis oil pressure switch	≥ 62% ON
High OK Duty ratio Variable valve lift diagnosis oil pressure switch	< 33% OFF

6. DTC CLEAR CONDITION

- When the OK idling cycle is completed 40 times in a row
- When "Clear Memory" is performed

7. MALFUNCTION INDICATOR LIGHT CLEAR CONDITION

- When the OK driving cycle is completed 3 times in a row
- When "Clear Memory" is performed

8. FAIL SAFE

None

9. ECM OPERATION AT DTC SETTING

Memorize the freeze frame data. (For test mode \$02)

Diagnostic Trouble Code (DTC) Detecting Criteria

GENERAL DESCRIPTION

B: DTC P0028 INTAKE VALVE CONTROL SOLENOID CIRCUIT RANGE/ PERFORMANCE (BANK 2)

NOTE:

For diagnostic procedures, refer to DTC P0026. <Ref. to GD(H4SO)-8, DTC P0026 INTAKE VALVE CONTROL SOLENOID CIRCUIT RANGE/PERFORMANCE (BANK 1), Diagnostic Trouble Code (DTC) Detecting Criteria.>

C: DTC P0030 HO2S HEATER CONTROL CIRCUIT (BANK 1 SENSOR 1)

1. OUTLINE OF DIAGNOSIS

Detect functional errors of the front oxygen (A/F) sensor heater.

Judge as NG when it is determined that the front oxygen (A/F) sensor impedance is large by referring to the engine condition such as fuel shut-off in deceleration, etc.

2. COMPONENT DESCRIPTION

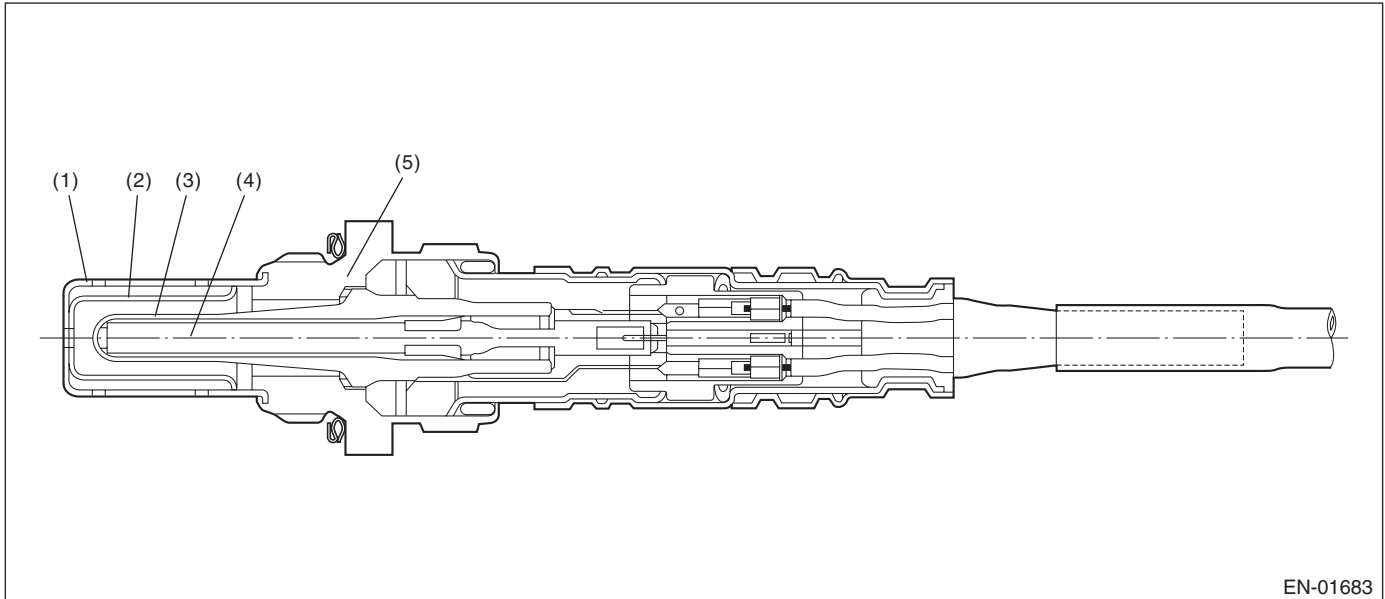

EN-01683

- | | | |
|---------------------------|--------------------|--------------------|
| (1) Element cover (outer) | (3) Sensor element | (5) Sensor housing |
| (2) Element cover (inner) | (4) Ceramic heater | |

3. ENABLE CONDITION

Secondary Parameters	Enable Conditions
Continuous time when all of the following conditions are met	30 seconds or more
Battery voltage	> 10.9 V
After fuel cut	20 seconds or more
Heater current	Operation
Front lambda sensor duty \geq 35%	Experienced

4. GENERAL DRIVING CYCLE

Perform the diagnosis continuously after 50 seconds or more have passed since the engine started.

5. DIAGNOSTIC METHOD

Judge as NG when the continuous time of meeting the malfunction criteria below becomes more than the time needed for diagnosis (10 seconds). Judge as OK and clear NG when the continuous time of not completing the malfunction criteria below becomes more than the time needed for diagnosis (10 seconds).

Judgment Value

Malfunction Criteria	Threshold Value
Front oxygen (A/F) sensor impedance	> 50 Ω

Time Needed for Diagnosis: 10 seconds

Malfunction Indicator Light Illumination: Illuminates when malfunction occurs in 2 continuous driving cycles.

Diagnostic Trouble Code (DTC) Detecting Criteria

GENERAL DESCRIPTION

6. DTC CLEAR CONDITION

- When the OK idling cycle is completed 40 times in a row
- When "Clear Memory" is performed

7. MALFUNCTION INDICATOR LIGHT CLEAR CONDITION

- When the OK driving cycle is completed 3 times in a row
- When "Clear Memory" is performed

8. FAIL SAFE

- Front oxygen (A/F) sensor main learning compensation: Not allowed to calculate.
- Front oxygen (A/F) sensor sub learning compensation: Not allowed to calculate.
- Purge control: Not allowed to purge.

9. ECM OPERATION AT DTC SETTING

Memorize the freeze frame data. (For test mode \$02)

D: DTC P0031 HO2S HEATER CONTROL CIRCUIT LOW (BANK 1 SENSOR 1)

1. OUTLINE OF DIAGNOSIS

Detect the open or short circuit of heater.

The heater performs duty control, and the output terminal voltage at ON is 0 V and the output terminal voltage at OFF is the battery voltage.

Judge NG when the terminal voltage remains Low.

2. COMPONENT DESCRIPTION

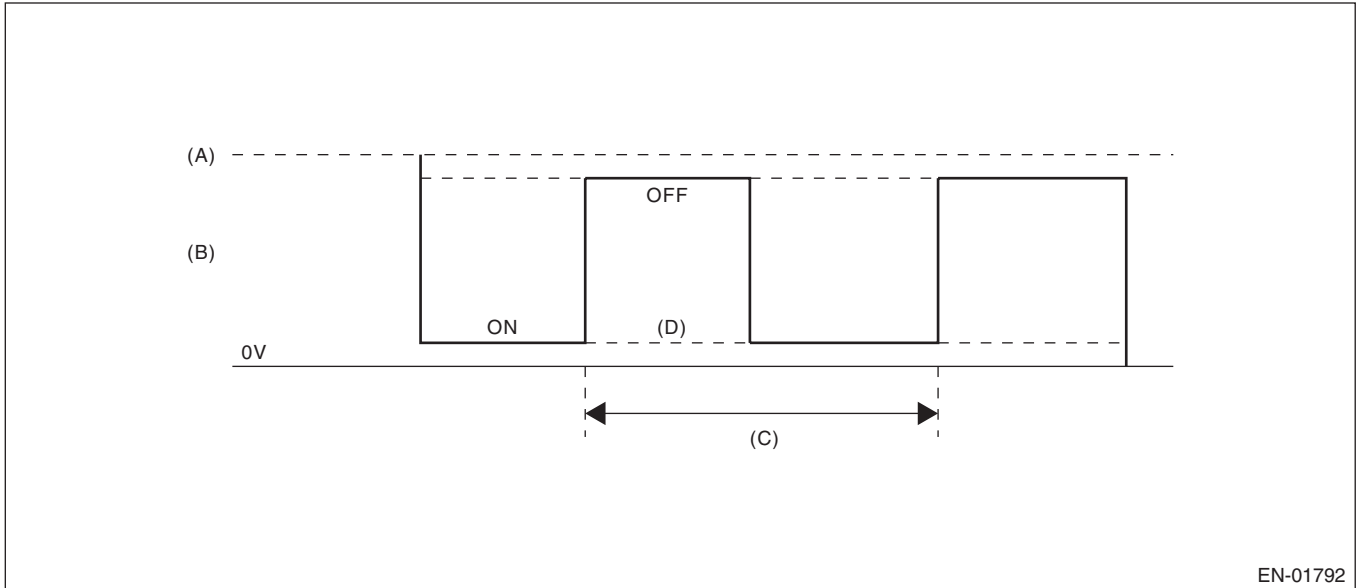

- | | |
|---|----------------------|
| (A) Battery voltage | (C) 128 milliseconds |
| (B) Front oxygen (A/F) sensor heater output voltage | (D) Low error |

3. ENABLE CONDITION

Secondary Parameters	Enable Conditions
Battery voltage	$\geq 10.9 \text{ V}$

4. GENERAL DRIVING CYCLE

Always perform the diagnosis continuously.

Diagnostic Trouble Code (DTC) Detecting Criteria

GENERAL DESCRIPTION

5. DIAGNOSTIC METHOD

Abnormality Judgment

Judge NG when the continuous time of meeting the malfunction criteria below becomes more than 1 second (8 cycles).

Judgment Value

Malfunction Criteria	Threshold Value
Output voltage level	Low
Front oxygen (A/F) sensor heater control duty	< 87.5%

Time Needed for Diagnosis: 1 second

Malfunction Indicator Light Illumination: Illuminates as soon as a malfunction occurs.

Normality Judgment

Judge as OK and clear the NG when the malfunction criteria below are completed.

Judgment Value

Malfunction Criteria	Threshold Value
Output voltage level	High

6. DTC CLEAR CONDITION

- When the OK idling cycle is completed 40 times in a row
- When "Clear Memory" is performed

7. MALFUNCTION INDICATOR LIGHT CLEAR CONDITION

- When the OK driving cycle is completed 3 times in a row
- When "Clear Memory" is performed

8. FAIL SAFE

- Front oxygen (A/F) sensor heater control: Not allowed to apply current to the heater.
- A/F main learning: Not allowed to calculate the A/F main learning compensation factor.
- A/F sub learning: Not allowed to calculate the A/F sub learning compensation factor.
- Purge control: Not allowed to purge.

9. ECM OPERATION AT DTC SETTING

Memorize the freeze frame data. (For test mode \$02)

Diagnostic Trouble Code (DTC) Detecting Criteria

GENERAL DESCRIPTION

E: DTC P0032 HO2S HEATER CONTROL CIRCUIT HIGH (BANK 1 SENSOR 1)

1. OUTLINE OF DIAGNOSIS

Detect the open or short circuit of heater.

The heater performs duty control, and the output terminal voltage at ON is 0 V and the output terminal voltage at OFF is the battery voltage.

Judge NG when the terminal voltage remains High.

2. COMPONENT DESCRIPTION

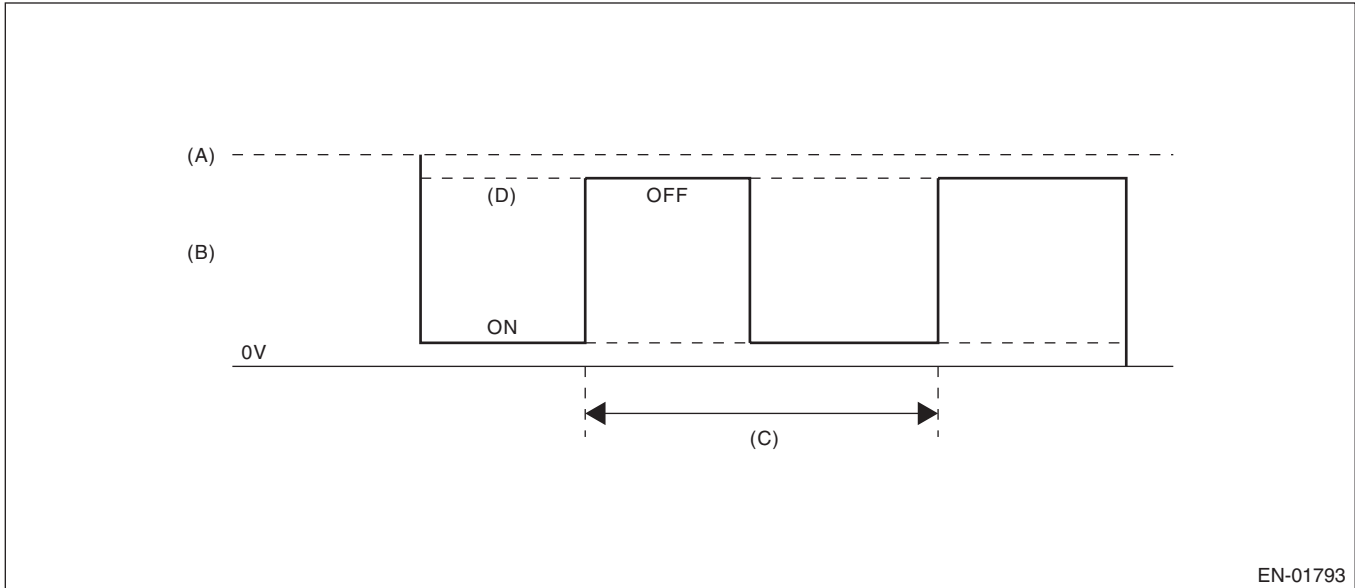

- | | |
|---|-------------------------------------|
| (A) Battery voltage | (C) 128 milliseconds |
| (B) Front oxygen (A/F) sensor heater output voltage | (D) High malfunction output voltage |

3. ENABLE CONDITION

Secondary Parameters	Enable Conditions
Battery voltage	$\geq 10.9 \text{ V}$

4. GENERAL DRIVING CYCLE

Always perform the diagnosis continuously.

Diagnostic Trouble Code (DTC) Detecting Criteria

GENERAL DESCRIPTION

5. DIAGNOSTIC METHOD

Abnormality Judgment

Judge NG when the continuous time of meeting the malfunction criteria below becomes more than 1 second (8 cycles).

Judgment Value

Malfunction Criteria	Threshold Value
Output voltage level	High
Front oxygen (A/F) sensor heater control duty	≥ 12.5%

Time Needed for Diagnosis: 1 second

Malfunction Indicator Light Illumination: Illuminates as soon as a malfunction occurs.

Normality Judgment

Judge as OK and clear the NG when the malfunction criteria below are completed.

Judgment Value

Malfunction Criteria	Threshold Value
Output voltage level	Low

6. DTC CLEAR CONDITION

- When the OK idling cycle is completed 40 times in a row
- When "Clear Memory" is performed

7. MALFUNCTION INDICATOR LIGHT CLEAR CONDITION

- When the OK driving cycle is completed 3 times in a row
- When "Clear Memory" is performed

8. FAIL SAFE

- Front oxygen (A/F) sensor heater control: Not allowed to apply current to the heater.
- A/F main learning: Not allowed to calculate the A/F main learning compensation factor.
- A/F sub learning: Not allowed to calculate the A/F sub learning compensation factor.
- Purge control: Not allowed to purge.

9. ECM OPERATION AT DTC SETTING

Memorize the freeze frame data. (For test mode \$02)

Diagnostic Trouble Code (DTC) Detecting Criteria

GENERAL DESCRIPTION

F: DTC P0037 HO2S HEATER CONTROL CIRCUIT LOW (BANK 1 SENSOR 2)

1. OUTLINE OF DIAGNOSIS

Detect the rear oxygen sensor heater open or short circuit.

The rear oxygen sensor heater performs duty control, and the output terminal voltage at ON is 0 V, and the output terminal voltage at OFF is the battery voltage.

Judge NG when the terminal voltage remains Low.

2. COMPONENT DESCRIPTION

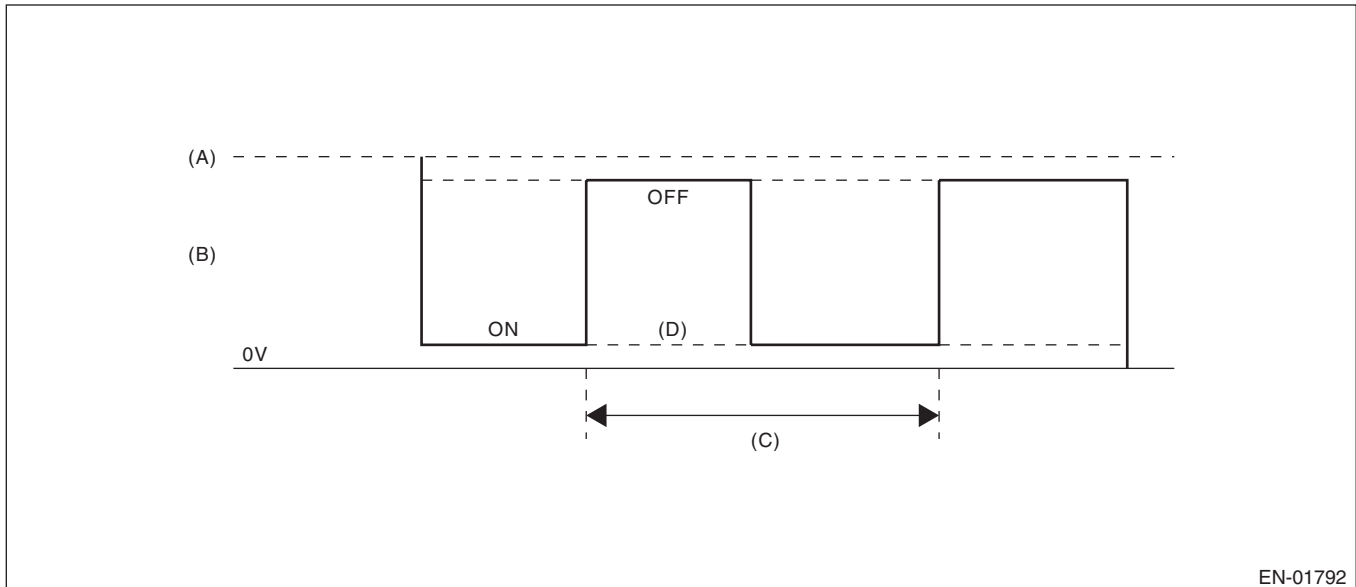

(A) Battery voltage

(C) 256 milliseconds (cycles)

(D) Low error

(B) Rear oxygen sensor heater output voltage

3. ENABLE CONDITION

Secondary Parameters	Enable Conditions
Battery voltage	> 10.9 V
Elapsed time after engine starting	≥ 1 sec.

4. GENERAL DRIVING CYCLE

Perform the diagnosis continuously after starting the engine.

Diagnostic Trouble Code (DTC) Detecting Criteria

GENERAL DESCRIPTION

5. DIAGNOSTIC METHOD

Abnormality Judgment

Judge as NG when the continuous time while meeting all of the malfunction criteria below is more than 2560 milliseconds (10 cycles).

Judgment Value

Malfunction Criteria	Threshold Value
Output voltage	Low
Rear oxygen sensor heater control duty	< 75%

Time Needed for Diagnosis: 2.56 seconds

Malfunction Indicator Light Illumination: Illuminates when malfunction occurs in 2 continuous driving cycles.

Normality Judgment

Judge as OK and clear the NG when the malfunction criteria below are completed.

Judgment Value

Malfunction Criteria	Threshold Value
Output voltage	High

6. DTC CLEAR CONDITION

- When the OK idling cycle is completed 40 times in a row
- When "Clear Memory" is performed

7. MALFUNCTION INDICATOR LIGHT CLEAR CONDITION

- When the OK driving cycle is completed 3 times in a row
- When "Clear Memory" is performed

8. FAIL SAFE

Sub feedback control: Not allowed.

9. ECM OPERATION AT DTC SETTING

Memorize the freeze frame data. (For test mode \$02)

Diagnostic Trouble Code (DTC) Detecting Criteria

GENERAL DESCRIPTION

G: DTC P0038 HO2S HEATER CONTROL CIRCUIT HIGH (BANK 1 SENSOR 2)

1. OUTLINE OF DIAGNOSIS

Detect the rear oxygen sensor heater open or short circuit.

The rear oxygen sensor heater performs duty control, and the output terminal voltage at ON is 0 V, and the output terminal voltage at OFF is the battery voltage.

Judge NG when the terminal voltage remains High.

2. COMPONENT DESCRIPTION

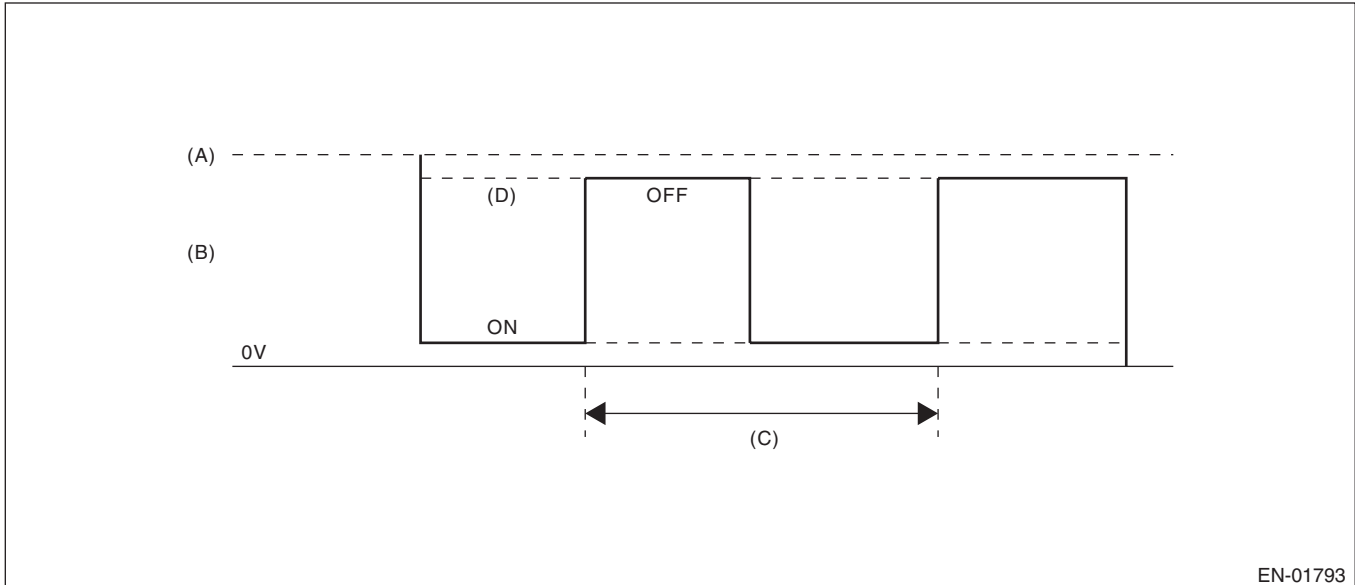

(A) Battery voltage

(C) 256 milliseconds (cycles)

(D) High malfunction

(B) Rear oxygen sensor heater output voltage

3. ENABLE CONDITION

Secondary Parameters	Enable Conditions
Battery voltage	> 10.9 V
Elapsed time after engine starting	≥ 1 sec.

4. GENERAL DRIVING CYCLE

Perform the diagnosis continuously after starting the engine.

Diagnostic Trouble Code (DTC) Detecting Criteria

GENERAL DESCRIPTION

5. DIAGNOSTIC METHOD

Abnormality Judgment

Judge as NG when the continuous time while meeting all of the malfunction criteria below is more than 2560 milliseconds (10 cycles).

Judgment Value

Malfunction Criteria	Threshold Value
Output voltage	High
Rear oxygen sensor heater control duty	≥ 20%

Time Needed for Diagnosis: 2.56 seconds

Malfunction Indicator Light Illumination: Illuminates when malfunction occurs in 2 continuous driving cycles.

Normality Judgment

Judge as OK and clear the NG when the malfunction criteria below are completed.

Judgment Value

Malfunction Criteria	Threshold Value
Output voltage	Low

6. DTC CLEAR CONDITION

- When the OK idling cycle is completed 40 times in a row
- When "Clear Memory" is performed

7. MALFUNCTION INDICATOR LIGHT CLEAR CONDITION

- When the OK driving cycle is completed 3 times in a row
- When "Clear Memory" is performed

8. FAIL SAFE

Sub feedback control: Not allowed.

9. ECM OPERATION AT DTC SETTING

Memorize the freeze frame data. (For test mode \$02)

Diagnostic Trouble Code (DTC) Detecting Criteria

GENERAL DESCRIPTION

H: DTC P0068 MAP/MAF - THROTTLE POSITION CORRELATION

1. OUTLINE OF DIAGNOSIS

Detect the malfunction of intake manifold pressure sensor output property. Judge NG when the intake air pressure AD value is Low whereas it seemed to be High from the viewpoint of engine condition, or when it is High whereas it seemed to be Low from the engine condition.

2. COMPONENT DESCRIPTION

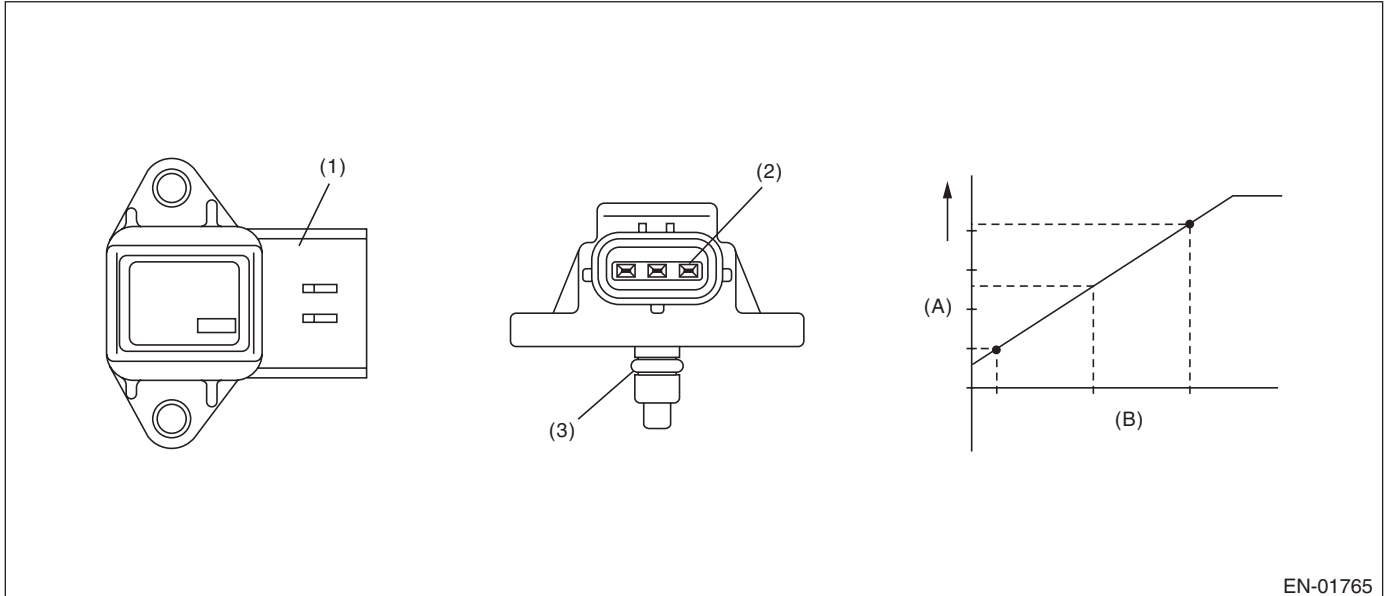

EN-01765

- (1) Connector
- (2) Terminals
- (3) O-ring
- (A) Output voltage
- (B) Absolute pressure

3. ENABLE CONDITION

Secondary Parameters	Enable Conditions
Engine coolant temperature	$\geq 75^{\circ}\text{C}$ (167°F)

4. GENERAL DRIVING CYCLE

Perform the diagnosis continuously after idling.

Diagnostic Trouble Code (DTC) Detecting Criteria

GENERAL DESCRIPTION

5. DIAGNOSTIC METHOD

Abnormality Judgment

Judge NG when either Low side or High side becomes NG.

Judge as NG when the continuous time of meeting the malfunction criteria below becomes more than the predetermined time.

Judgment Value

Malfunction Criteria	Threshold Value
Low side	
Engine speed	< 2500 rpm
Throttle position	$\geq 12^\circ$
Intake air amount every 0.5 engine revs.	$\geq 0.55 \text{ g (0.019 oz)/rev}$
Output voltage	< 1.4 V
High side	
Engine speed	600 — 900 rpm
Throttle position	$\leq 2.44^\circ$
Intake air amount every 0.5 engine revs.	< 0.4 g (0.014 oz)/rev
Output voltage	$\geq 3.4 \text{ V}$

Time Needed for Diagnosis: 3 seconds for low side, 7 seconds for high side

Malfunction Indicator Light Illumination: Illuminates when malfunction occurs in 2 continuous driving cycles.

Normality Judgment

Judge as OK and clear the NG when both Low side and High side become OK.

Judge as OK when the malfunction criteria below are completed.

Judgment Value

Malfunction Criteria	Threshold Value
Low side	
Engine speed	< 2500 rpm
Throttle position	$\geq 12^\circ$
Intake air amount every 0.5 engine revs.	$\geq 0.55 \text{ g (0.019 oz)/rev}$
Output voltage	$\geq 1.4 \text{ V}$
High side	
Engine speed	600 — 900 rpm
Throttle position	$\leq 2.44^\circ$
Intake air amount every 0.5 engine revs.	< 0.4 g (0.014 oz)/rev
Output voltage	< 3.4 V

6. DTC CLEAR CONDITION

- When the OK idling cycle is completed 40 times in a row
- When "Clear Memory" is performed

7. MALFUNCTION INDICATOR LIGHT CLEAR CONDITION

- When the OK driving cycle is completed 3 times in a row
- When "Clear Memory" is performed

8. FAIL SAFE

- Intake manifold pressure sensor process: Estimate the pressure from engine load.
- ISC feedback: Not allowed to calculate the amount of feedback.

9. ECM OPERATION AT DTC SETTING

Memorize the freeze frame data. (For test mode \$02)

Diagnostic Trouble Code (DTC) Detecting Criteria

GENERAL DESCRIPTION

I: DTC P0076 INTAKE VALVE CONTROL SOLENOID CIRCUIT LOW (BANK 1)

1. OUTLINE OF DIAGNOSIS

Detect the open circuit of the oil switching solenoid valve.

Judge as NG when the current is small even though the output duty is large.

2. ENABLE CONDITION

Secondary Parameters	Enable Conditions
Battery voltage	≥ 10.9 V

3. GENERAL DRIVING CYCLE

Always perform the diagnosis continuously.

4. DIAGNOSTIC METHOD

Abnormality Judgment

Judge as NG when the continuous time when the following conditions are established is more than 2 seconds.

Judgment Value

Malfunction Criteria	Threshold Value
Duty ratio	$\geq 30\%$
Control current	< 0.026 A

Time Needed for Diagnosis: 2 seconds

Malfunction Indicator Light Illumination: Illuminates as soon as a malfunction occurs.

Normality Judgment

Judge as OK and clear the NG when the continuous time when the following conditions are established is more than 2 seconds.

Judgment Value

Malfunction Criteria	Threshold Value
$ \text{Oil switching solenoid valve target current value} - \text{oil switching solenoid valve current value} $	< 0.08 A
Control current	≥ 0.11 A

5. DTC CLEAR CONDITION

- When the OK idling cycle is completed 40 times in a row
- When "Clear Memory" is performed

6. MALFUNCTION INDICATOR LIGHT CLEAR CONDITION

- When the OK driving cycle is completed 3 times in a row
- When "Clear Memory" is performed

7. FAIL SAFE

None

8. ECM OPERATION AT DTC SETTING

Memorize the freeze frame data. (For test mode \$02)

Diagnostic Trouble Code (DTC) Detecting Criteria

GENERAL DESCRIPTION

J: DTC P0077 INTAKE VALVE CONTROL SOLENOID CIRCUIT HIGH (BANK 1)

1. OUTLINE OF DIAGNOSIS

Detect short circuits of the oil switching solenoid valve.

Judge as a short NG when the current is large even though the output duty is small.

2. ENABLE CONDITION

Secondary Parameters	Enable Conditions
Battery voltage	$\geq 10.9 \text{ V}$

3. GENERAL DRIVING CYCLE

Always perform the diagnosis continuously.

4. DIAGNOSTIC METHOD

Abnormality Judgment

Judge as NG when the continuous time when the following conditions are established is more than 2 seconds.

Judgment Value

Malfunction Criteria	Threshold Value
Duty ratio	$< 7\%$
Control current	$\geq 0.465 \text{ A}$

Time Needed for Diagnosis: 2 seconds

Malfunction Indicator Light Illumination: Illuminates as soon as a malfunction occurs.

Normality Judgment

Judge as OK and clear the NG when the continuous time when the following conditions are established is more than 2 seconds.

Judgment Value

Malfunction Criteria	Threshold Value
Oil switching solenoid valve target current value – oil switching solenoid valve current value	$< 0.08 \text{ A}$

5. DTC CLEAR CONDITION

- When the OK idling cycle is completed 40 times in a row
- When “Clear Memory” is performed

6. MALFUNCTION INDICATOR LIGHT CLEAR CONDITION

- When the OK driving cycle is completed 3 times in a row
- When “Clear Memory” is performed

7. FAIL SAFE

None

8. ECM OPERATION AT DTC SETTING

Memorize the freeze frame data. (For test mode \$02)

Diagnostic Trouble Code (DTC) Detecting Criteria

GENERAL DESCRIPTION

K: DTC P0082 INTAKE VALVE CONTROL SOLENOID CIRCUIT LOW (BANK 2)

NOTE:

For the diagnostic procedure, refer to DTC P0076. <Ref. to GD(H4SO)-23, DTC P0076 INTAKE VALVE CONTROL SOLENOID CIRCUIT LOW (BANK 1), Diagnostic Trouble Code (DTC) Detecting Criteria.>

L: DTC P0083 INTAKE VALVE CONTROL SOLENOID CIRCUIT HIGH (BANK 2)

NOTE:

For the diagnostic procedure, refer to DTC P0077. <Ref. to GD(H4SO)-24, DTC P0077 INTAKE VALVE CONTROL SOLENOID CIRCUIT HIGH (BANK 1), Diagnostic Trouble Code (DTC) Detecting Criteria.>

Diagnostic Trouble Code (DTC) Detecting Criteria

GENERAL DESCRIPTION

M: DTC P0101 MASS OR VOLUME AIR FLOW CIRCUIT RANGE/PERFORMANCE

1. OUTLINE OF DIAGNOSIS

Detect the malfunction of air flow sensor output property.

Judge as a low side NG when the air flow voltage indicates a small value regardless of running in a state where the air flow voltage increases. Judge as High side NG when the air flow voltage indicates a large value regardless of running in a state where the air flow voltage decreases. Judge air flow sensor property NG when the Low side or High side becomes NG.

2. COMPONENT DESCRIPTION

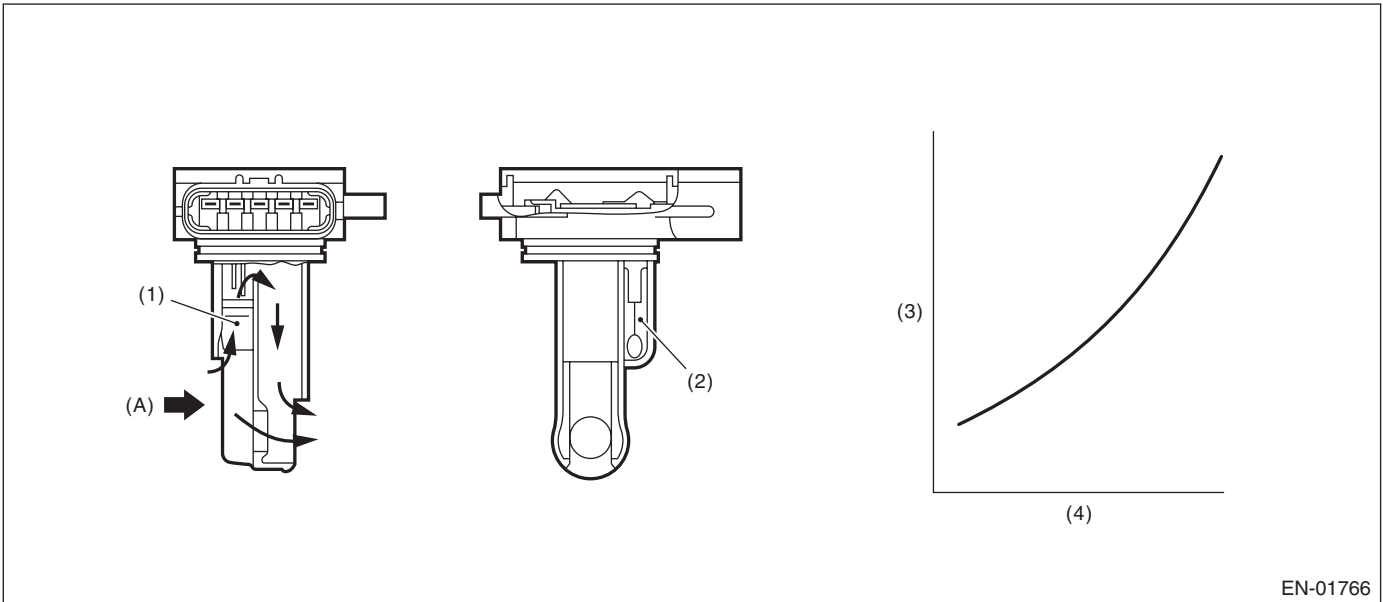

EN-01766

(1) Air flow sensor

(2) Intake air temperature sensor

(3) Voltage (V)

(4) Intake air volume (kg/s)

(A) Air

3. ENABLE CONDITION

Secondary Parameters	Enable Conditions
Engine coolant temperature	$\geq 75^{\circ}\text{C}$ (167°F)

4. GENERAL DRIVING CYCLE

Perform the diagnosis continuously after idling.

Diagnostic Trouble Code (DTC) Detecting Criteria

GENERAL DESCRIPTION

5. DIAGNOSTIC METHOD

Abnormality Judgment

Judge as NG when the continuous time with the following criteria established exceeds the predetermined time.

Judgment Value

Malfunction Criteria	Threshold Value
(Low side error) Output voltage Engine speed Throttle opening angle Intake manifold pressure	< 1.2 V ≥ 2000 rpm ≥ 13° ≥ 53.3 kPa (400 mmHg, 15.7 inHg)
(High side error 1) Output voltage Engine speed Throttle opening angle Intake manifold pressure	≥ 2.66 V 600 — 900 rpm < 2.44° < 40.0 kPa (300 mmHg, 11.8 inHg)
(High side error 2) Output voltage Engine speed Throttle opening angle Intake manifold pressure Fuel system diagnosis	≥ 1.45 V 600 — 900 rpm < 2.44° < 40.0 kPa (300 mmHg, 11.8 inHg) Rich side malfunction

Time Needed for Diagnosis:

Low side : 3 seconds

High side: 10 seconds

Malfunction Indicator Light Illumination: Illuminates when malfunction occurs in 2 continuous driving cycles.

Normality Judgment

Judge as OK when the criteria below are met.

Judgment Value

Malfunction Criteria	Threshold Value
(Low side error) Output voltage Engine speed Throttle opening angle Intake manifold pressure	≥ 1.2 V ≥ 2000 rpm ≥ 13° ≥ 53.3 kPa (400 mmHg, 15.7 inHg)
(High side error) Output voltage Engine Speed Throttle opening angle Intake manifold pressure	< 2.66 V 600 — 900 rpm < 2.44° < 40.0 kPa (300 mmHg, 11.8 inHg)

Diagnostic Trouble Code (DTC) Detecting Criteria

GENERAL DESCRIPTION

6. DTC CLEAR CONDITION

- When the OK idling cycle is completed 40 times in a row
- When "Clear Memory" is performed

7. MALFUNCTION INDICATOR LIGHT CLEAR CONDITION

- When the OK driving cycle is completed 3 times in a row
- When "Clear Memory" is performed

8. FAIL SAFE

None

9. ECM OPERATION AT DTC SETTING

Memorize the freeze frame data. (For test mode \$02)

N: DTC P0102 MASS OR VOLUME AIR FLOW CIRCUIT LOW INPUT

1. OUTLINE OF DIAGNOSIS

Detect open or short circuits of the air flow sensor.
Judge as NG if it is out of specification.

2. COMPONENT DESCRIPTION

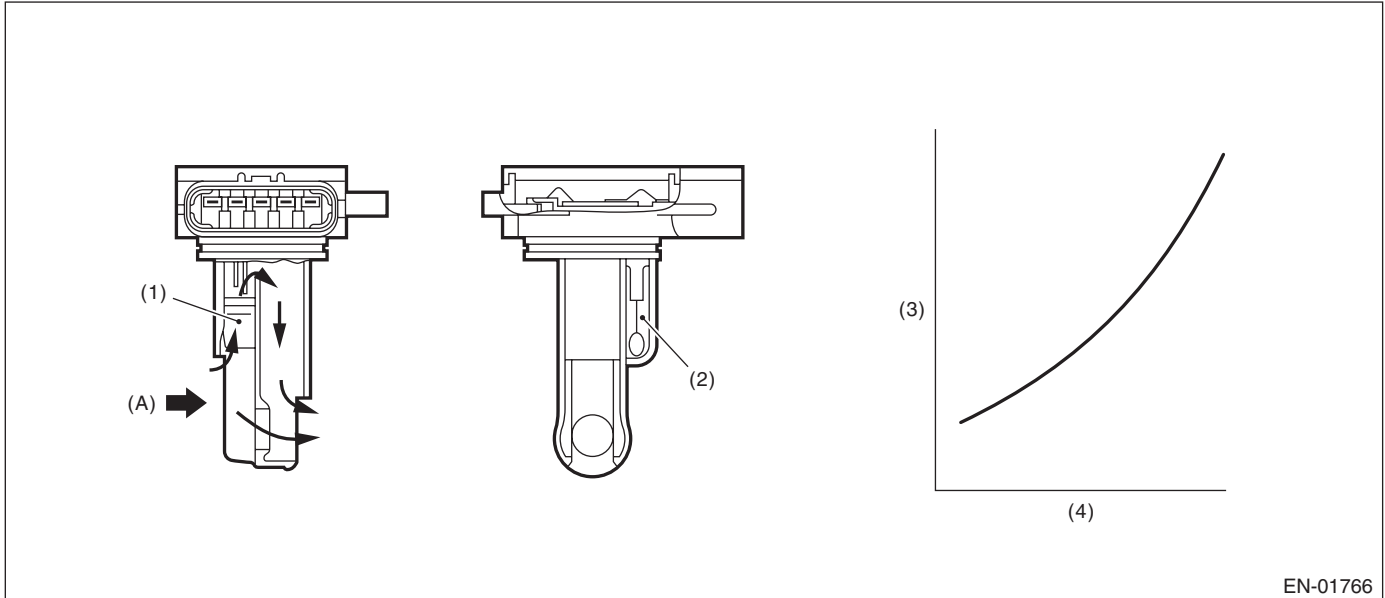

EN-01766

- | | | |
|-----------------------------------|------------------------------|---------|
| (1) Air flow sensor | (3) Voltage (V) | (A) Air |
| (2) Intake air temperature sensor | (4) Intake air volume (kg/s) | |

3. ENABLE CONDITION

Secondary Parameters	Enable Conditions
None	

4. GENERAL DRIVING CYCLE

Always perform the diagnosis continuously.

5. DIAGNOSTIC METHOD

Judge as NG when the continuous time of meeting the malfunction criteria below becomes 0.5 seconds or more. Judge as OK and clear the NG when the malfunction criteria below are not met.

Judgment Value

Malfunction Criteria	Threshold Value
Output voltage	$\leq 0.2 \text{ V}$

Time Needed for Diagnosis: 0.5 seconds

Malfunction Indicator Light Illumination: Illuminates as soon as a malfunction occurs.

6. DTC CLEAR CONDITION

- When the OK idling cycle is completed 40 times in a row
- When "Clear Memory" is performed

7. MALFUNCTION INDICATOR LIGHT CLEAR CONDITION

- When the OK driving cycle is completed 3 times in a row
- When "Clear Memory" is performed

Diagnostic Trouble Code (DTC) Detecting Criteria

GENERAL DESCRIPTION

8. FAIL SAFE

None

9. ECM OPERATION AT DTC SETTING

Memorize the freeze frame data. (For test mode \$02)

O: DTC P0103 MASS OR VOLUME AIR FLOW CIRCUIT HIGH INPUT

1. OUTLINE OF DIAGNOSIS

Detect open or short circuits of the air flow sensor.
 Judge as NG if it is out of specification.

2. COMPONENT DESCRIPTION

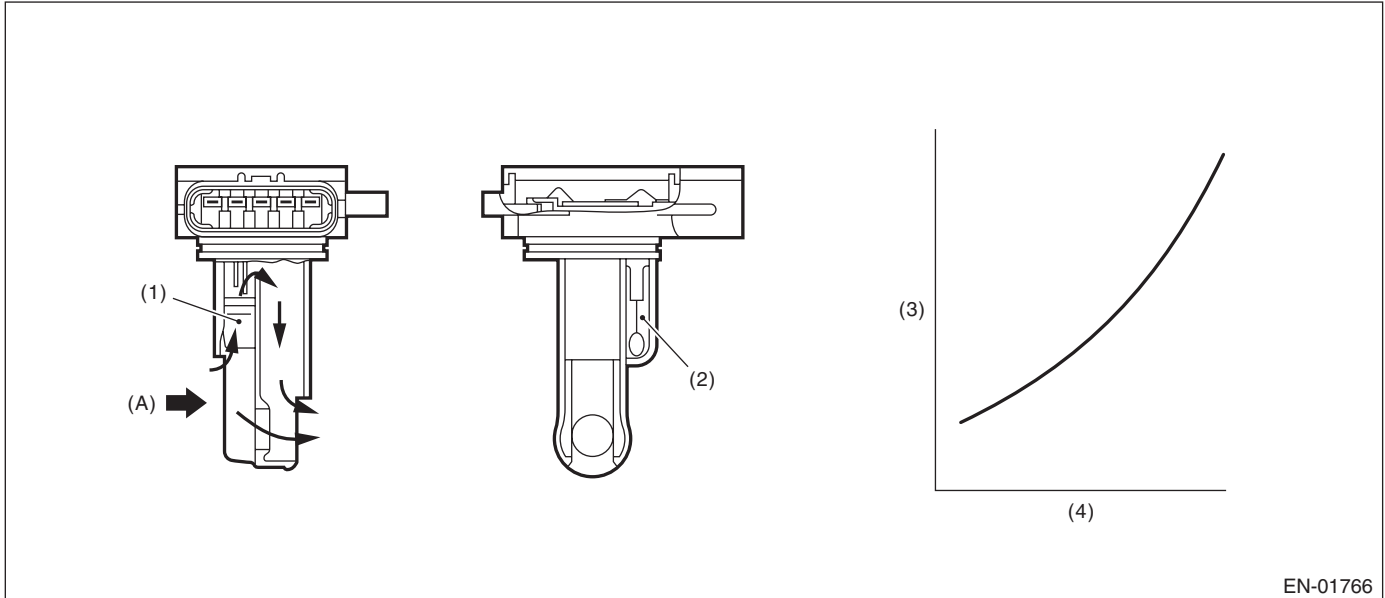

EN-01766

- | | | |
|-----------------------------------|------------------------------|---------|
| (1) Air flow sensor | (3) Voltage (V) | (A) Air |
| (2) Intake air temperature sensor | (4) Intake air volume (kg/s) | |

3. ENABLE CONDITION

Secondary Parameters	Enable Conditions
None	

4. GENERAL DRIVING CYCLE

Always perform the diagnosis continuously.

5. DIAGNOSTIC METHOD

Judge NG when the continuous time of meeting the malfunction criteria below becomes more than 0.5 seconds. Judge as OK and clear the NG when the malfunction criteria below are not met.

Judgment Value

Malfunction Criteria	Threshold Value
Output voltage	≥ 4.985 V

Time Needed for Diagnosis: 0.5 seconds

Malfunction Indicator Light Illumination: Illuminates as soon as a malfunction occurs.

6. DTC CLEAR CONDITION

- When the OK idling cycle is completed 40 times in a row
- When "Clear Memory" is performed

7. MALFUNCTION INDICATOR LIGHT CLEAR CONDITION

- When the OK driving cycle is completed 3 times in a row
- When "Clear Memory" is performed

Diagnostic Trouble Code (DTC) Detecting Criteria

GENERAL DESCRIPTION

8. FAIL SAFE

None

9. ECM OPERATION AT DTC SETTING

Memorize the freeze frame data. (For test mode \$02)

P: DTC P0107 MANIFOLD ABSOLUTE PRESSURE/BAROMETRIC PRESSURE CIRCUIT LOW INPUT

1. OUTLINE OF DIAGNOSIS

Detect the open or short circuit of intake manifold pressure sensor.
Judge as NG if it is out of specification.

2. COMPONENT DESCRIPTION

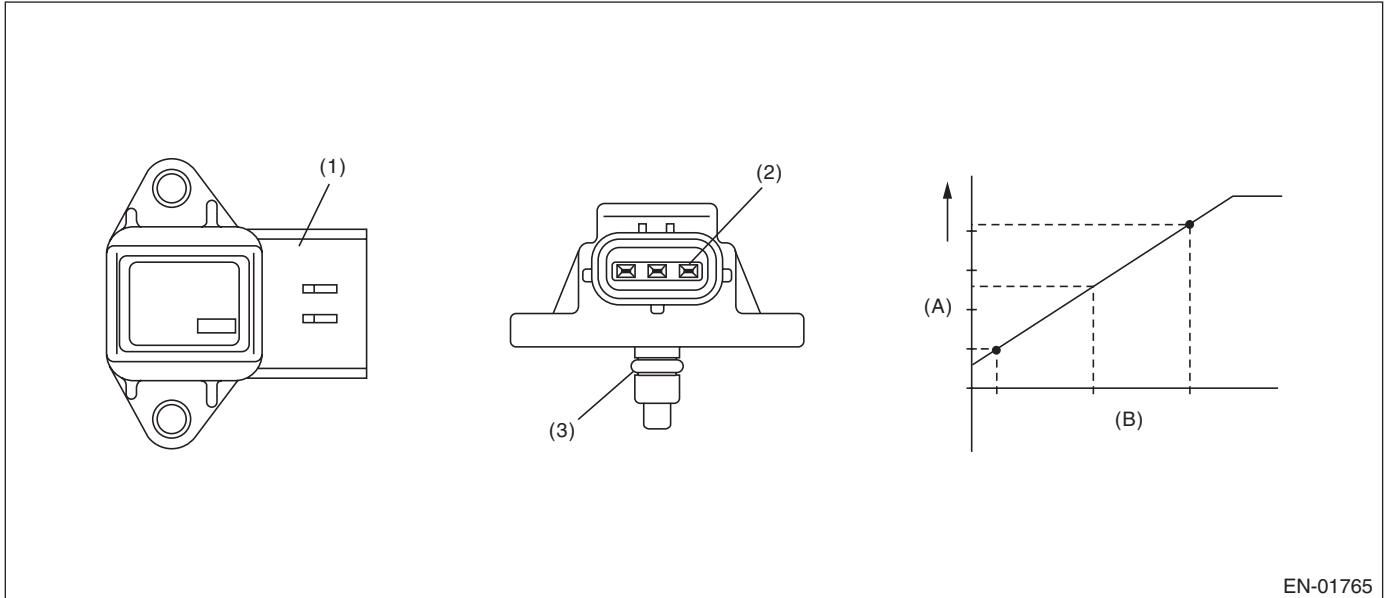

EN-01765

- | | |
|---------------|-----------------------|
| (1) Connector | (A) Output voltage |
| (2) Terminals | (B) Absolute pressure |
| (3) O-ring | |

3. ENABLE CONDITION

Secondary Parameters	Enable Conditions
None	

4. GENERAL DRIVING CYCLE

Always perform the diagnosis continuously.

5. DIAGNOSTIC METHOD

Judge as NG when the continuous time of meeting the malfunction criteria below becomes 0.5 seconds or more. Judge as OK and clear the NG when the malfunction criteria below are not met.

Judgment Value

Malfunction Criteria	Threshold Value
Output voltage	< 0.568 V

Time Needed for Diagnosis: 0.5 seconds

Malfunction Indicator Light Illumination: Illuminates as soon as a malfunction occurs.

6. DTC CLEAR CONDITION

- When the OK idling cycle is completed 40 times in a row
- When "Clear Memory" is performed

7. MALFUNCTION INDICATOR LIGHT CLEAR CONDITION

- When the OK driving cycle is completed 3 times in a row
- When "Clear Memory" is performed

Diagnostic Trouble Code (DTC) Detecting Criteria

GENERAL DESCRIPTION

8. FAIL SAFE

ISC feedback: Not allowed to calculate the amount of feedback.

9. ECM OPERATION AT DTC SETTING

Memorize the freeze frame data. (For test mode \$02)

Q: DTC P0108 MANIFOLD ABSOLUTE PRESSURE/BAROMETRIC PRESSURE CIRCUIT HIGH INPUT

1. OUTLINE OF DIAGNOSIS

Detect the open or short circuit of intake manifold pressure sensor.
Judge as NG if it is out of specification.

2. COMPONENT DESCRIPTION

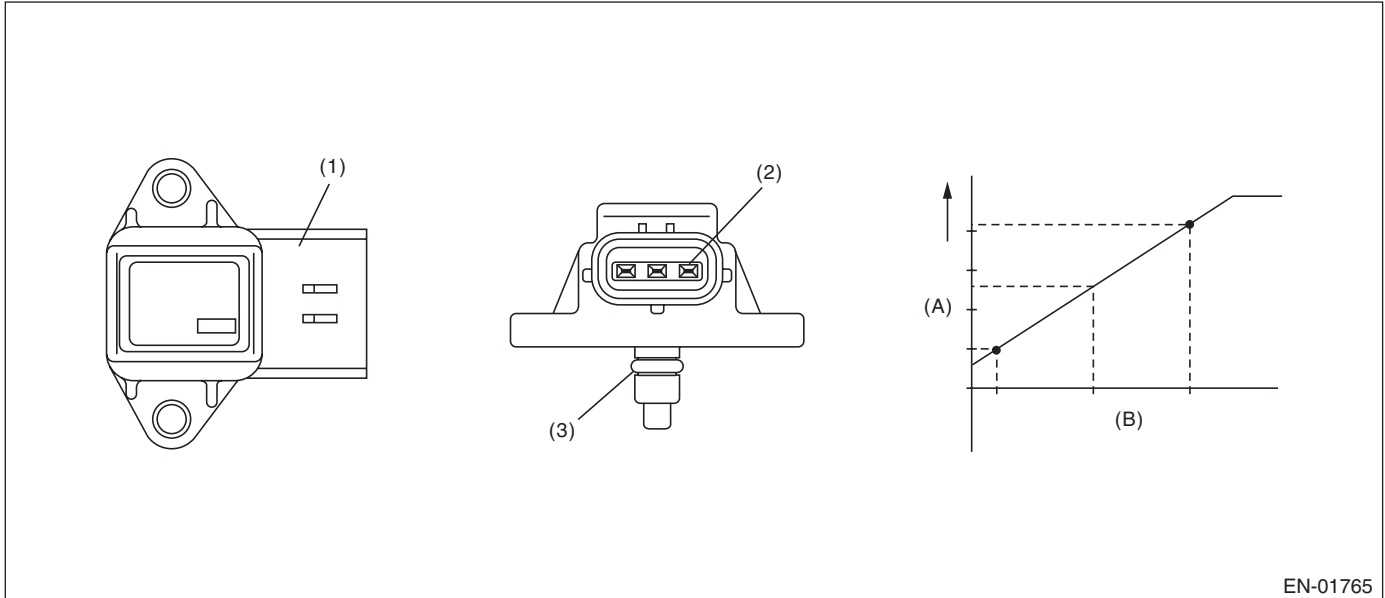

EN-01765

- | | |
|---------------|-----------------------|
| (1) Connector | (A) Output voltage |
| (2) Terminals | (B) Absolute pressure |
| (3) O-ring | |

3. ENABLE CONDITION

Secondary Parameters	Enable Conditions
None	

4. GENERAL DRIVING CYCLE

Always perform the diagnosis continuously.

5. DIAGNOSTIC METHOD

Judge as NG when the continuous time of meeting the malfunction criteria below becomes 0.5 seconds or more. Judge as OK and clear the NG when the malfunction criteria below are not met.

Judgment Value

Malfunction Criteria	Threshold Value
Output voltage	≥ 4.921 V

Time Needed for Diagnosis: 0.5 seconds

Malfunction Indicator Light Illumination: Illuminates as soon as a malfunction occurs.

6. DTC CLEAR CONDITION

- When the OK idling cycle is completed 40 times in a row
- When "Clear Memory" is performed

7. MALFUNCTION INDICATOR LIGHT CLEAR CONDITION

- When the OK driving cycle is completed 3 times in a row
- When "Clear Memory" is performed

Diagnostic Trouble Code (DTC) Detecting Criteria

GENERAL DESCRIPTION

8. FAIL SAFE

ISC feedback: Not allowed to calculate the amount of feedback.

9. ECM OPERATION AT DTC SETTING

Memorize the freeze frame data. (For test mode \$02)

R: DTC P0111 INTAKE AIR TEMPERATURE SENSOR 1 CIRCUIT RANGE/ PERFORMANCE

1. OUTLINE OF DIAGNOSIS

Detect the malfunction of intake air temperature sensor output property.

Judge as NG when the intake air temperature is not varied whereas it seemed to be varied from the viewpoint of engine condition.

2. COMPONENT DESCRIPTION

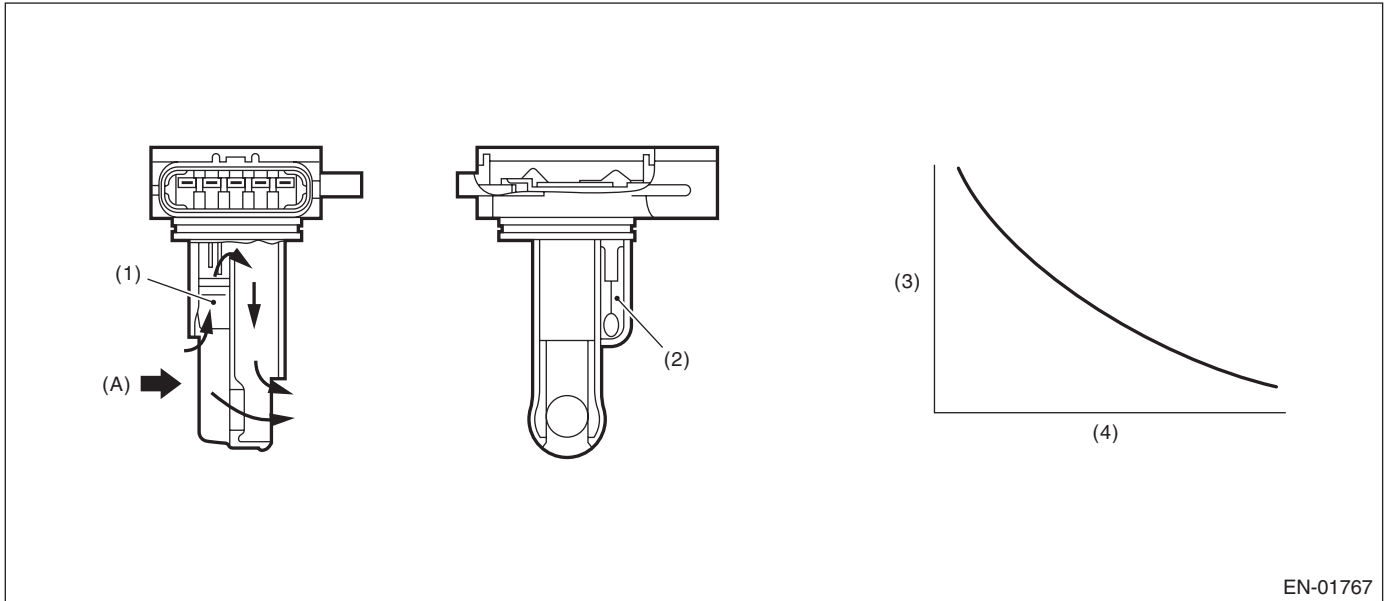

EN-01767

(1) Air flow sensor

(2) Intake air temperature sensor

(3) Resistance value (Ω)

(4) Intake air temperature °C (°F)

(A) Air

3. ENABLE CONDITION

Secondary Parameters	Enable Conditions
Coolant temp. before engine start	< 30°C (86°F)
Engine coolant temperature	> 100°C (212°F)
Battery voltage	≥ 10.9 V
Continuous time when the vehicle speed is less than 60 km/h (37 MPH)	600 seconds or more

4. GENERAL DRIVING CYCLE

Perform the diagnosis when the vehicle speed condition is completed after starting and idling the cold engine.

Diagnostic Trouble Code (DTC) Detecting Criteria

GENERAL DESCRIPTION

5. DIAGNOSTIC METHOD

Abnormality Judgment

Judge as NG when the continuous time of meeting the malfunction criteria below becomes 1 seconds or more.

Judgment Value

Malfunction Criteria	Threshold Value
Output voltage difference between Max. and Min.	< 20 mV (Equivalent to approximately 0.5°C (0.9°F) near 25°C)

Time Needed for Diagnosis: 1 second

Malfunction Indicator Light Illumination: Illuminates when malfunction occurs in 2 continuous driving cycles.

Normality Judgment

Judge as OK and clear the NG when the malfunction criteria below are met.

Judgment Value

Malfunction Criteria	Threshold Value
Output voltage difference between Max. and Min.	≥ 20 mV

6. DTC CLEAR CONDITION

- When the OK idling cycle is completed 40 times in a row
- When "Clear Memory" is performed

7. MALFUNCTION INDICATOR LIGHT CLEAR CONDITION

- When the OK driving cycle is completed 3 times in a row
- When "Clear Memory" is performed

8. FAIL SAFE

Intake air temperature sensor process: Intake air temperature is fixed at 20°C (68°F).

9. ECM OPERATION AT DTC SETTING

Memorize the freeze frame data. (For test mode \$02)

S: DTC P0112 INTAKE AIR TEMPERATURE SENSOR 1 CIRCUIT LOW

1. OUTLINE OF DIAGNOSIS

Detect open or short circuit of the intake air temperature sensor.
 Judge as NG if it is out of specification.

2. COMPONENT DESCRIPTION

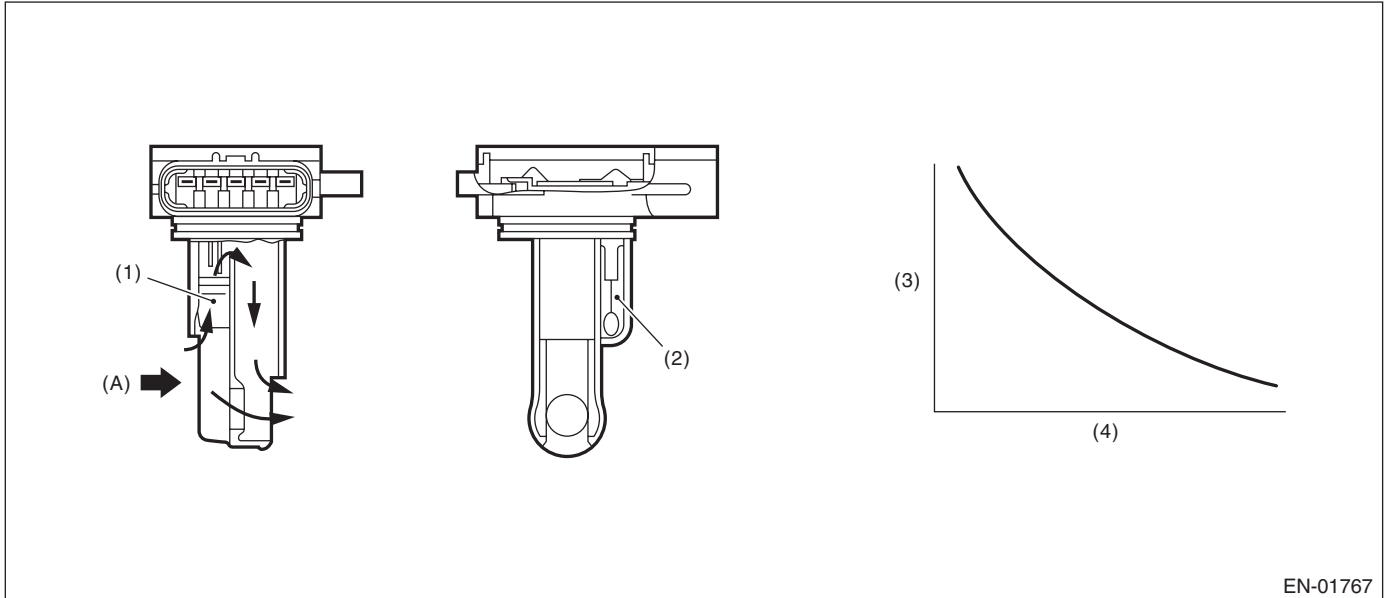

EN-01767

- | | | |
|-----------------------------------|--|---------|
| (1) Air flow sensor | (3) Resistance value (Ω) | (A) Air |
| (2) Intake air temperature sensor | (4) Intake air temperature $^{\circ}\text{C}$ ($^{\circ}\text{F}$) | |

3. ENABLE CONDITION

Secondary Parameters	Enable Conditions
None	

4. GENERAL DRIVING CYCLE

Always perform the diagnosis continuously.

5. DIAGNOSTIC METHOD

Abnormality Judgment

Judge as NG when the continuous time of meeting the malfunction criteria below becomes 0.5 seconds or more.

Judgment Value

Malfunction Criteria	Threshold Value
Output voltage	< 0.166 V
Ignition switch	ON

Time Needed for Diagnosis: 0.5 seconds

Malfunction Indicator Light Illumination: Illuminates as soon as a malfunction occurs.

Normality Judgment

Judge as OK and clear the NG when the malfunction criteria below are met.

Judgment Value

Malfunction Criteria	Threshold Value
Output voltage	≥ 0.166 V
Ignition switch	ON

Diagnostic Trouble Code (DTC) Detecting Criteria

GENERAL DESCRIPTION

6. DTC CLEAR CONDITION

- When the OK idling cycle is completed 40 times in a row
- When "Clear Memory" is performed

7. MALFUNCTION INDICATOR LIGHT CLEAR CONDITION

- When the OK driving cycle is completed 3 times in a row
- When "Clear Memory" is performed

8. FAIL SAFE

Intake air temperature sensor process: Intake air temperature is fixed at 20°C (68°F).

9. ECM OPERATION AT DTC SETTING

Memorize the freeze frame data. (For test mode \$02)

T: DTC P0113 INTAKE AIR TEMPERATURE SENSOR 1 CIRCUIT HIGH

1. OUTLINE OF DIAGNOSIS

Detect open or short circuit of the intake air temperature sensor.
Judge as NG if it is out of specification.

2. COMPONENT DESCRIPTION

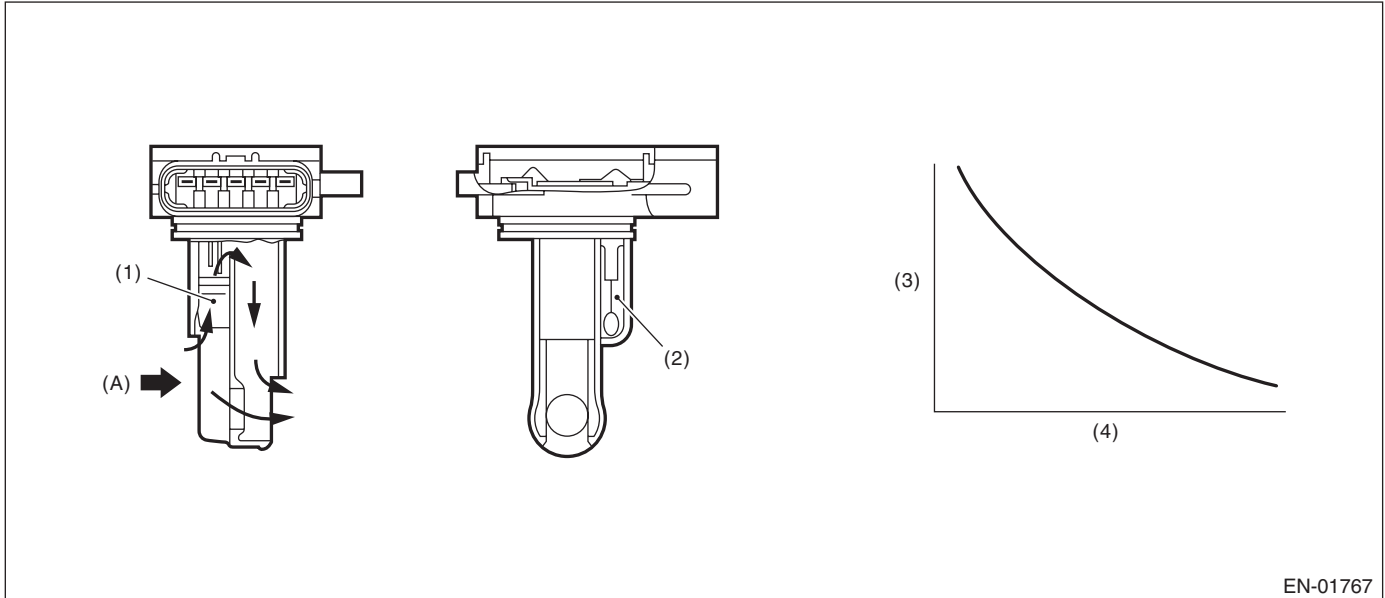

EN-01767

- | | | |
|-----------------------------------|--|---------|
| (1) Air flow sensor | (3) Resistance value (Ω) | (A) Air |
| (2) Intake air temperature sensor | (4) Intake air temperature $^{\circ}\text{C}$ ($^{\circ}\text{F}$) | |

3. ENABLE CONDITION

Secondary Parameters	Enable Conditions
None	

4. GENERAL DRIVING CYCLE

Always perform the diagnosis continuously.

5. DIAGNOSTIC METHOD

Abnormality Judgment

Judge as NG when the continuous time of meeting the malfunction criteria below becomes 0.5 seconds or more.

Judgment Value

Malfunction Criteria	Threshold Value
Output voltage	$\geq 4.716 \text{ V}$
Ignition switch	ON

Time Needed for Diagnosis: 0.5 seconds

Malfunction Indicator Light Illumination: Illuminates as soon as a malfunction occurs.

Normality Judgment

Judge as OK and clear the NG when the malfunction criteria below are met.

Judgment Value

Malfunction Criteria	Threshold Value
Output voltage	$< 4.716 \text{ V}$
Ignition switch	ON

Diagnostic Trouble Code (DTC) Detecting Criteria

GENERAL DESCRIPTION

6. DTC CLEAR CONDITION

- When the OK idling cycle is completed 40 times in a row
- When "Clear Memory" is performed

7. MALFUNCTION INDICATOR LIGHT CLEAR CONDITION

- When the OK driving cycle is completed 3 times in a row
- When "Clear Memory" is performed

8. FAIL SAFE

Intake air temperature sensor process: Intake air temperature is fixed at 20°C (68°F).

9. ECM OPERATION AT DTC SETTING

Memorize the freeze frame data. (For test mode \$02)

U: DTC P0117 ENGINE COOLANT TEMPERATURE CIRCUIT LOW

1. OUTLINE OF DIAGNOSIS

Detect the open or short circuit of the engine coolant temperature sensor.
Judge as NG if it is out of specification.

2. COMPONENT DESCRIPTION

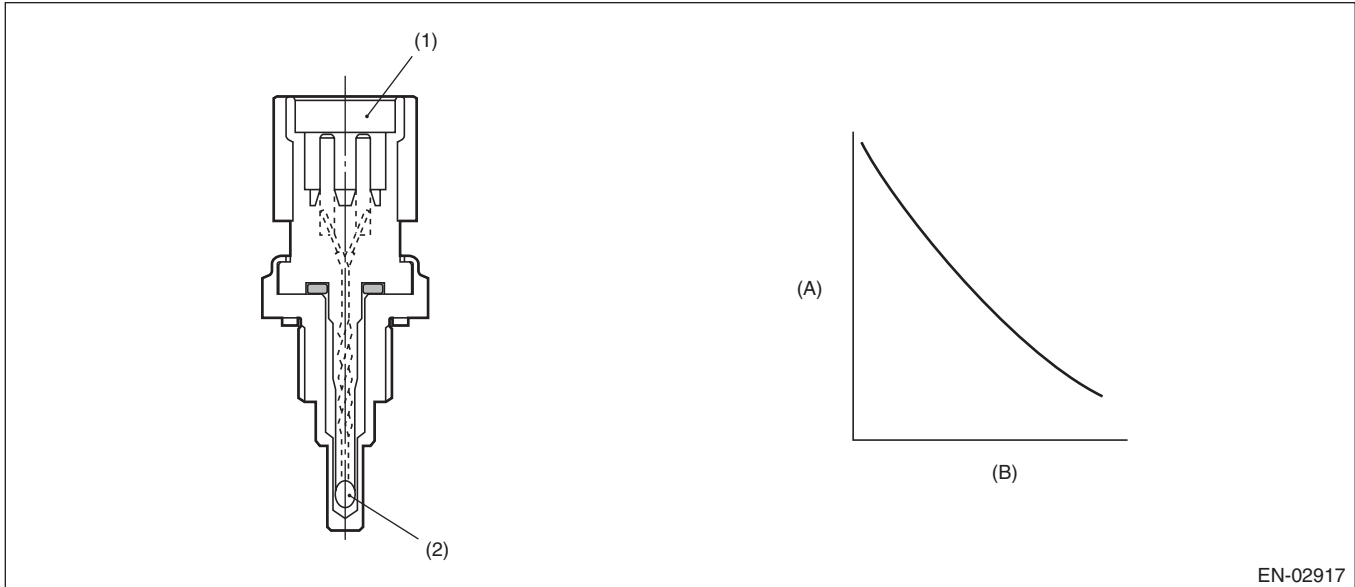

EN-02917

- | | |
|------------------------|---------------------------|
| (1) Connector | (A) Resistance value (kΩ) |
| (2) Thermistor element | (B) Temperature °C (°F) |

3. ENABLE CONDITION

Secondary Parameters	Enable Conditions
None	

4. GENERAL DRIVING CYCLE

Always perform the diagnosis continuously.

5. DIAGNOSTIC METHOD

Judge as NG when the continuous time of meeting the malfunction criteria below becomes 0.5 seconds or more. Judge as OK and clear the NG when the malfunction criteria below are not met.

Judgment Value

Malfunction Criteria	Threshold Value
Output voltage	≤ 0.166 V

Time Needed for Diagnosis: 0.5 seconds

Malfunction Indicator Light Illumination: Illuminates as soon as a malfunction occurs.

6. DTC CLEAR CONDITION

- When the OK idling cycle is completed 40 times in a row
- When "Clear Memory" is performed

7. MALFUNCTION INDICATOR LIGHT CLEAR CONDITION

- When the OK driving cycle is completed 3 times in a row
- When "Clear Memory" is performed

Diagnostic Trouble Code (DTC) Detecting Criteria

GENERAL DESCRIPTION

8. FAIL SAFE

- Engine coolant temperature sensor process: Engine coolant temperature is fixed at 70°C (158°F)
- ISC Feedback: Calculate target engine speed as engine coolant temperature 70°C (158°F).
- ISC learning: Not allowed to learn.
- Air conditioner control: Not allowed to turn the air conditioner to ON.
- Radiator fan control: Both main and sub fan turn to ON.
- Tumble generator valve control: Open the tumble generator valve.

9. ECM OPERATION AT DTC SETTING

Memorize the freeze frame data. (For test mode \$02)

V: DTC P0118 ENGINE COOLANT TEMPERATURE CIRCUIT HIGH

1. OUTLINE OF DIAGNOSIS

Detect the open or short circuit of the engine coolant temperature sensor.
Judge as NG if it is out of specification.

2. COMPONENT DESCRIPTION

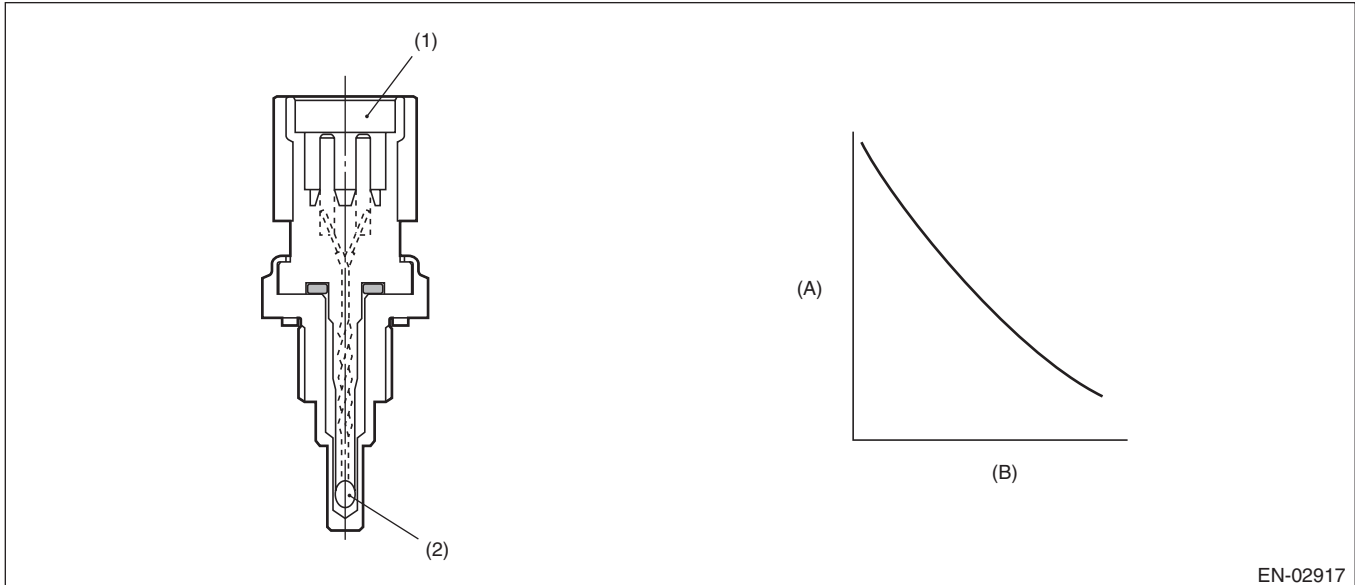

EN-02917

- | | |
|------------------------|---------------------------|
| (1) Connector | (A) Resistance value (kΩ) |
| (2) Thermistor element | (B) Temperature °C (°F) |

3. ENABLE CONDITION

Secondary Parameters	Enable Conditions
None	

4. GENERAL DRIVING CYCLE

Always perform the diagnosis continuously.

5. DIAGNOSTIC METHOD

Judge as NG when the continuous time of meeting the malfunction criteria below becomes 0.5 seconds or more. Judge as OK and clear the NG when the malfunction criteria below are not met.

Judgment Value

Malfunction Criteria	Threshold Value
Output voltage	≥ 4.716 V

Time Needed for Diagnosis: 0.5 seconds

Malfunction Indicator Light Illumination: Illuminates as soon as a malfunction occurs.

6. DTC CLEAR CONDITION

- When the OK idling cycle is completed 40 times in a row
- When "Clear Memory" is performed

7. MALFUNCTION INDICATOR LIGHT CLEAR CONDITION

- When the OK driving cycle is completed 3 times in a row
- When "Clear Memory" is performed

Diagnostic Trouble Code (DTC) Detecting Criteria

GENERAL DESCRIPTION

8. FAIL SAFE

- Engine coolant temperature sensor process: Engine coolant temperature is fixed at 70°C (158°F)
- ISC Feedback: Calculate target engine speed as engine coolant temperature 70°C (158°F).
- ISC learning: Not allowed to learn.
- Air conditioner control: Not allowed to turn the air conditioner to ON.
- Radiator fan control: Both main and sub fan turn to ON.
- Tumble generator valve control: Open the tumble generator valve.

9. ECM OPERATION AT DTC SETTING

Memorize the freeze frame data. (For test mode \$02)

W: DTC P0122 THROTTLE/PEDAL POSITION SENSOR/SWITCH “A” CIRCUIT LOW

1. OUTLINE OF DIAGNOSIS

Detect the open or short circuit of throttle position sensor 1.
Judge as NG if it is out of specification.

2. COMPONENT DESCRIPTION

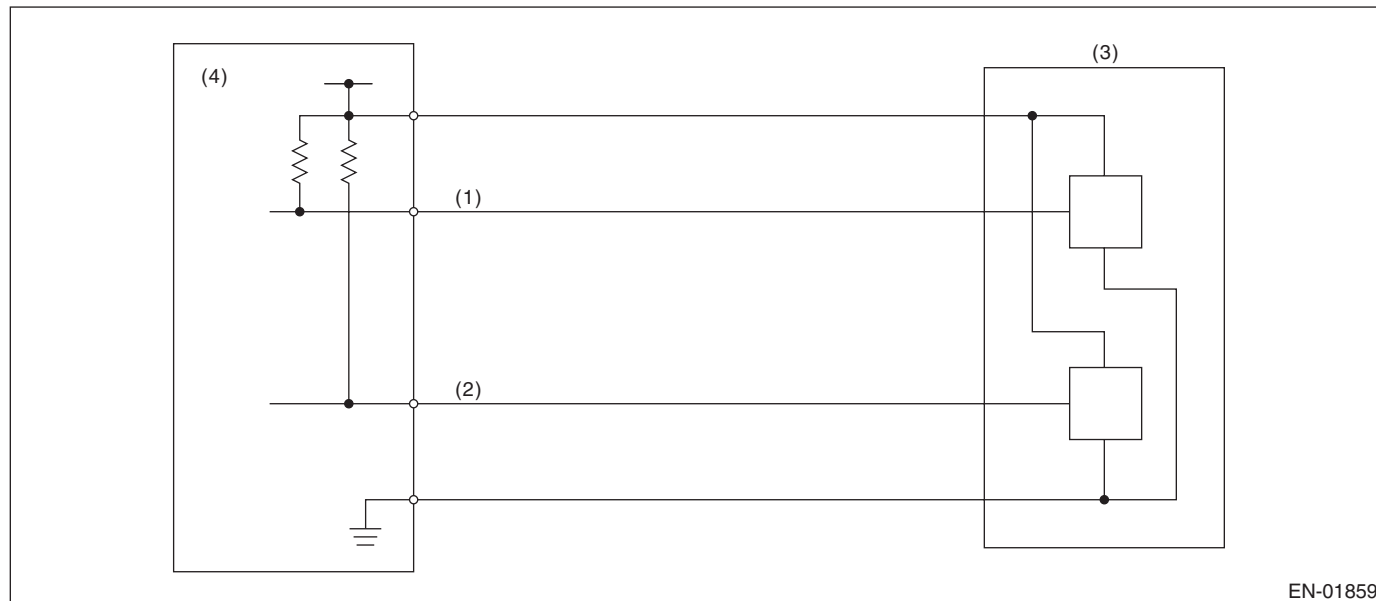

EN-01859

- | | |
|---------------------------------------|---------------------------------|
| (1) Throttle position sensor 1 signal | (3) Throttle position sensor |
| (2) Throttle position sensor 2 signal | (4) Engine control module (ECM) |

3. ENABLE CONDITION

Secondary Parameters	Enable Conditions
Ignition switch	ON

4. GENERAL DRIVING CYCLE

Always perform the diagnosis continuously.

5. DIAGNOSTIC METHOD

Judge as OK and clear the NG when the malfunction criteria below are met.

Judgment Value

Malfunction Criteria	Threshold Value
Sensor 1 input voltage	≥ 0.309 V

Time Needed for Diagnosis: 24 milliseconds

Malfunction Indicator Light Illumination: Illuminates as soon as a malfunction occurs.

6. DTC CLEAR CONDITION

- When the OK idling cycle is completed 40 times in a row
- When “Clear Memory” is performed (Only with engine stopped)

7. MALFUNCTION INDICATOR LIGHT CLEAR CONDITION

- When the OK driving cycle is completed 3 times in a row
- When “Clear Memory” is performed (Only with engine stopped)

Diagnostic Trouble Code (DTC) Detecting Criteria

GENERAL DESCRIPTION

8. FAIL SAFE

Stop the continuity to the electronic throttle control motor. (Throttle opening is fixed to 6°.)

9. ECM OPERATION AT DTC SETTING

Memorize the freeze frame data. (For test mode \$02)

X: DTC P0123 THROTTLE/PEDAL POSITION SENSOR/SWITCH “A” CIRCUIT HIGH

1. OUTLINE OF DIAGNOSIS

Detect the open or short circuit of throttle position sensor 1.
Judge as NG if it is out of specification.

2. COMPONENT DESCRIPTION

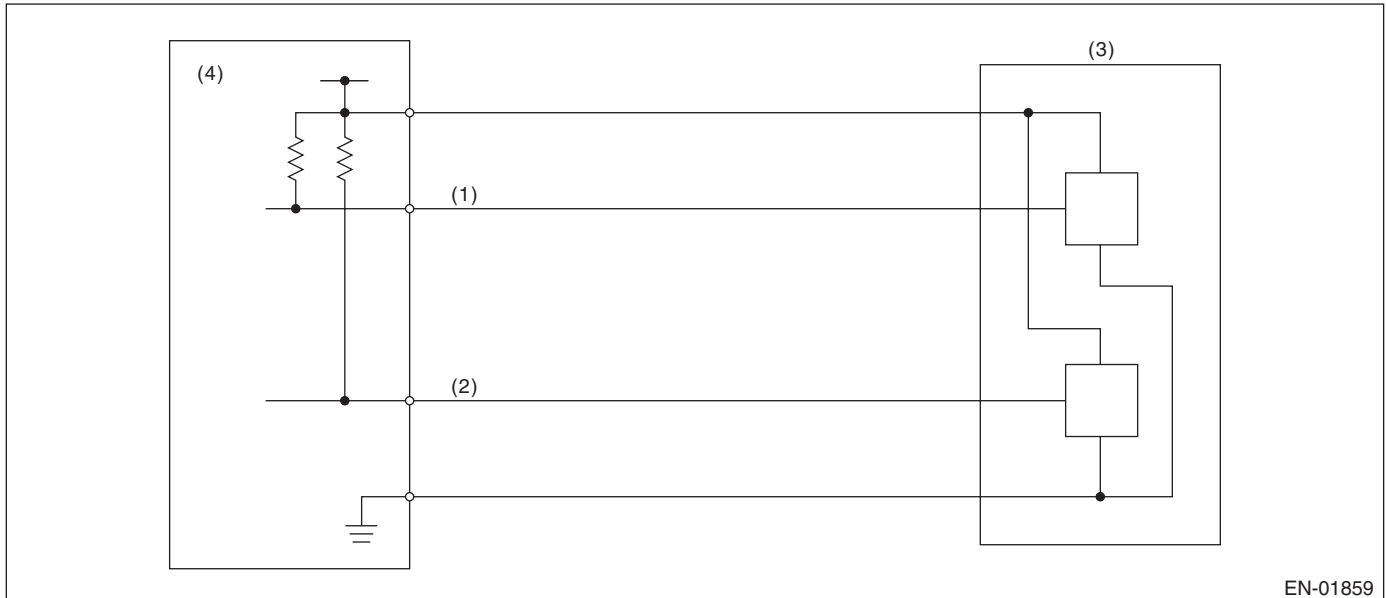

EN-01859

- (1) Throttle position sensor 1 signal (3) Throttle position sensor (4) Engine control module (ECM)
 (2) Throttle position sensor 2 signal

3. ENABLE CONDITION

Secondary Parameters	Enable Conditions
Ignition switch	ON

4. GENERAL DRIVING CYCLE

Always perform the diagnosis continuously.

5. DIAGNOSTIC METHOD

Judge as OK and clear the NG when the malfunction criteria below are met.

Judgment Value

Malfunction Criteria	Threshold Value
Sensor 1 input voltage	≤ 4.646 V

Time Needed for Diagnosis: 24 milliseconds

Malfunction Indicator Light Illumination: Illuminates as soon as a malfunction occurs.

6. DTC CLEAR CONDITION

- When the OK idling cycle is completed 40 times in a row
- When “Clear Memory” is performed (Only with engine stopped)

7. MALFUNCTION INDICATOR LIGHT CLEAR CONDITION

- When the OK driving cycle is completed 3 times in a row
- When “Clear Memory” is performed (Only with engine stopped)

Diagnostic Trouble Code (DTC) Detecting Criteria

GENERAL DESCRIPTION

8. FAIL SAFE

Stop the continuity to the electronic throttle control motor. (Throttle opening is fixed to 6°.)

9. ECM OPERATION AT DTC SETTING

Memorize the freeze frame data. (For test mode \$02)

Y: DTC P0125 INSUFFICIENT COOLANT TEMPERATURE FOR CLOSED LOOP FUEL CONTROL

1. OUTLINE OF DIAGNOSIS

Detect the malfunction of engine coolant temperature output property.

Judge as NG when the engine coolant temperature does not rise in driving conditions where it should.

2. COMPONENT DESCRIPTION

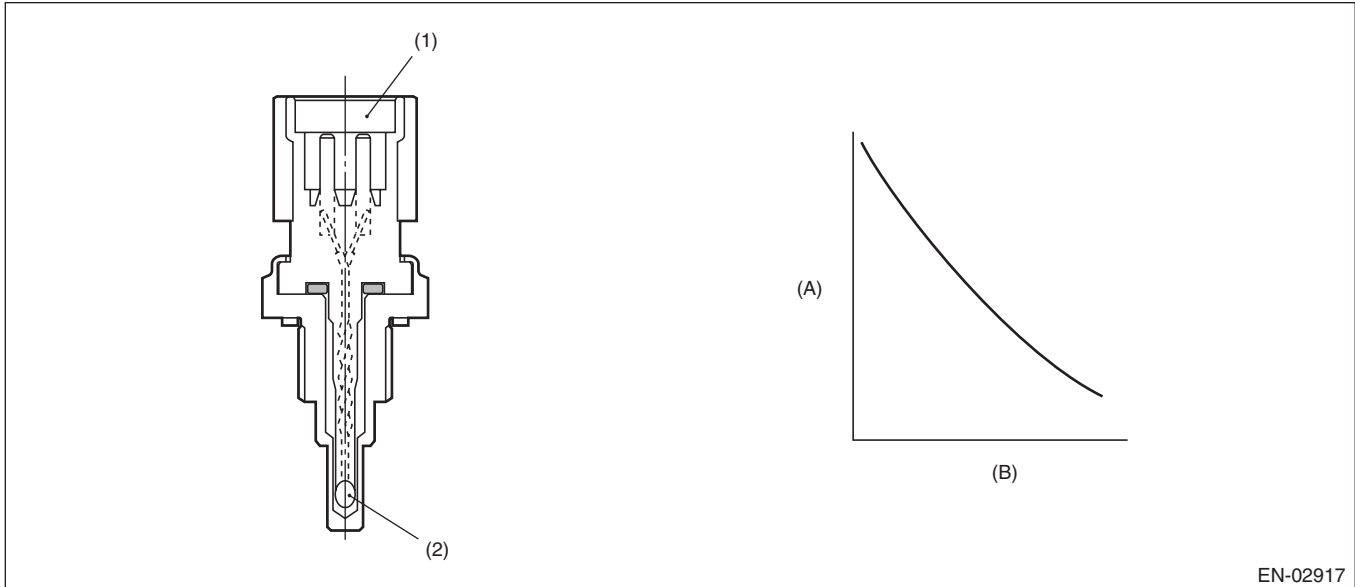

EN-02917

- (1) Connector
- (2) Thermistor element

- (A) Resistance value (kΩ)
- (B) Temperature °C (°F)

3. ENABLE CONDITION

Secondary Parameters	Enable Conditions
Engine speed	≥ 500 rpm
Battery voltage	> 10.9 V

4. GENERAL DRIVING CYCLE

Perform the diagnosis only once after engine starting.

5. DIAGNOSTIC METHOD

Abnormality Judgment

Judge as NG when the malfunction criteria below are met.

Judgment Value

Malfunction Criteria	Threshold Value
Engine coolant temperature	< 20°C (68°F)
Timer for diagnosis after engine starting	≥ Judgment value of timer after engine starting

Diagnostic Trouble Code (DTC) Detecting Criteria

GENERAL DESCRIPTION

Timer for diagnosis after engine starting

a. Timer stop at fuel cut mode.

b. During the driving conditions except a) above, timer counts up.

64 milliseconds + TWCNT milliseconds (at the time of 64 milliseconds)

TWCNT is defined as follows.

TWCNT = 0 (at idle switch ON)

TWCNT at idle switch OFF is shown in the following table.

		Vehicle speed km/h (MPH)							
		0 (0)	8 (5)	16 (10)	24 (15)	32 (20)	40 (25)	48 (30)	56 (35)
Temperature °C (°F)	-20 (-4)	0 ms	32.076 ms	39.977 ms	47.879 ms	82.544 ms	117.209 ms	154.214 ms	185.206 ms
	-10 (14)	0 ms	25.704 ms	33.606 ms	41.508 ms	68.520 ms	95.532 ms	125.667 ms	155.802 ms
	0 (32)	0 ms	17.646 ms	25.548 ms	33.450 ms	53.652 ms	73.855 ms	97.120 ms	120.386 ms
	10 (50)	0 ms	7.901 ms	15.802 ms	23.704 ms	37.941 ms	52.177 ms	68.573 ms	82.538 ms

Judgment value of timer after engine starting

$t = 574 - 33 \times T_i$ (seconds)

T_i : The lowest engine coolant temperature after starting the engine

Time Needed for Diagnosis: Undetermined. (It is varied by the lowest engine coolant temperature and engine conditions such as vehicle speed and engine coolant temperature.)

Malfunction Indicator Light Illumination: Illuminates when malfunction occurs in 2 continuous driving cycles.

Normality Judgment

Judge as OK and clear the NG when the malfunction criteria below are met.

Judgment Value

Malfunction Criteria	Threshold Value
Engine coolant temperature	$\geq 20^\circ\text{C}$ (68°F)

6. DTC CLEAR CONDITION

- When the OK idling cycle is completed 40 times in a row
- When "Clear Memory" is performed

7. MALFUNCTION INDICATOR LIGHT CLEAR CONDITION

- When the OK driving cycle is completed 3 times in a row
- When "Clear Memory" is performed

8. FAIL SAFE

- Engine coolant temperature sensor process: Engine coolant temperature is fixed at 70°C (158°F)
- ISC Feedback: Calculate target engine speed as engine coolant temperature 70°C (158°F).
- ISC learning: Not allowed to learn.
- Air conditioner control: Not allowed to turn the air conditioner to ON.
- Radiator fan control: Both main and sub fan turn to ON.
- Tumble generator valve control: Open the tumble generator valve.

9. ECM OPERATION AT DTC SETTING

Memorize the freeze frame data. (For test mode \$02)

Z: DTC P0126 INSUFFICIENT ENGINE COOLANT TEMPERATURE FOR STABLE OPERATION

1. OUTLINE OF DIAGNOSIS

Detect the malfunction of the engine coolant temperature sensor characteristics.

Memorize the engine coolant temperature and fuel temperature at the last engine stop, and use them to judge as NG when the engine coolant temperature does not decrease when it should.

2. COMPONENT DESCRIPTION

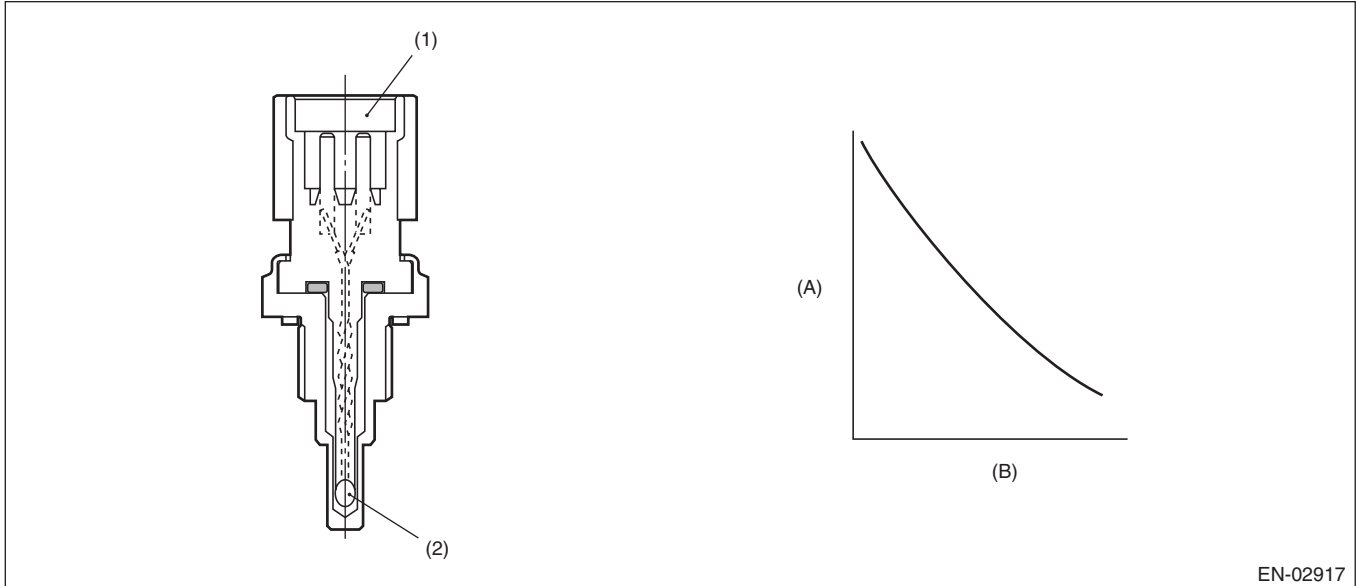

EN-02917

- (1) Connector
- (2) Thermistor element

- (A) Resistance value (kΩ)
- (B) Temperature °C (°F)

3. ENABLE CONDITION

Secondary Parameters	Enable Conditions
Battery voltage	≥ 10.9 V
Refueling from the last engine stop till the current engine start	None
Fuel level	15.0 ℓ (3.96 US gal, 3.3 Imp gal)
Engine coolant temperature at the last engine stop	≥ 75°C (167°F) and < 100°C (212°F)

Diagnostic Trouble Code (DTC) Detecting Criteria

GENERAL DESCRIPTION

4. GENERAL DRIVING CYCLE

Perform the diagnosis only once after starting the engine.

5. DIAGNOSTIC METHOD

Abnormality Judgment

Judge as NG if the continuous time with the following conditions established is more than 2.5 seconds.

Judgment Value

Malfunction Criteria	Threshold Value
Engine coolant temperature at the last engine stop – Minimum engine coolant temperature after the engine start	< 2.5°C (4.5°F)
Fuel temperature at the last engine stop – fuel temperature	5°C (9°F)
Intake air temperature – fuel temperature	2.5°C (4.5°F)
Fuel temperature	35°C (95°F)

Normality Judgment

When the following conditions are established, judged as OK.

Judgment Value

Malfunction Criteria	Threshold Value
Engine coolant temperature at the last engine stop – Minimum engine coolant temperature after the engine start	≥ 2.5°C (4.5°F)

Time Needed for Diagnosis: 2.5 seconds

Malfunction Indicator Light Illumination: Illuminates when malfunction occurs in 2 continuous driving cycles.

6. DTC CLEAR CONDITION

- When the OK idling cycle is completed 40 times in a row
- When “Clear Memory” is performed

7. MALFUNCTION INDICATOR LIGHT CLEAR CONDITION

- When the OK driving cycle is completed 3 times in a row
- When “Clear Memory” is performed

8. FAIL SAFE

None

9. ECM OPERATION AT DTC SETTING

Memorize the freeze frame data. (For test mode \$02)

AA:DTC P0128 COOLANT THERMOSTAT (ENGINE COOLANT TEMPERATURE BELOW THERMOSTAT REGULATING TEMPERATURE)

1. OUTLINE OF DIAGNOSIS

Detect malfunctions of the thermostat function.

Judge as NG when the engine coolant temperature is lower than the estimated engine coolant temperature and the difference between them is large. Judge as OK when the engine coolant temperature comes to 70°C (158°F), and the difference is small, before judging NG.

2. COMPONENT DESCRIPTION

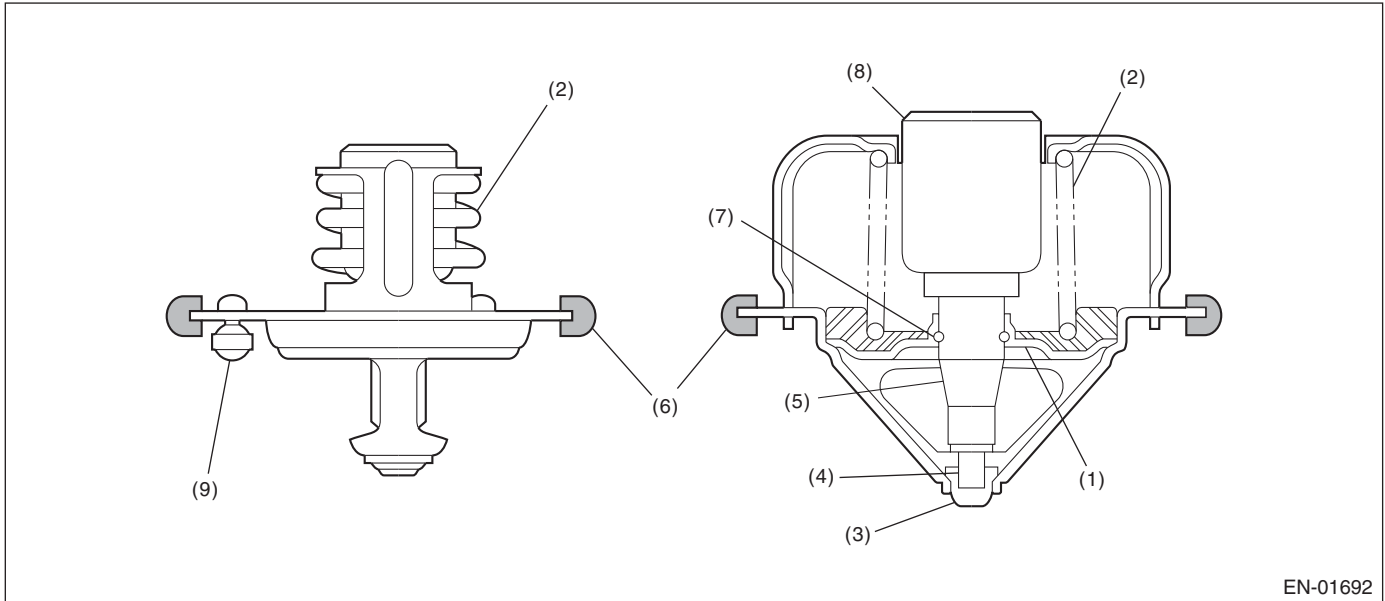

EN-01692

- | | | |
|-------------|--------------------|------------------|
| (1) Valve | (4) Piston | (7) Stop ring |
| (2) Spring | (5) Guide | (8) Wax element |
| (3) Stopper | (6) Rubber packing | (9) Jiggle valve |

3. ENABLE CONDITION

Secondary Parameters	Enable Conditions
None	

4. GENERAL DRIVING CYCLE

Always perform the diagnosis continuously.

Diagnostic Trouble Code (DTC) Detecting Criteria

GENERAL DESCRIPTION

5. DIAGNOSTIC METHOD

Abnormality Judgment

Judge as NG when the continuous time of meeting the malfunction criteria below becomes 30 seconds or more.

Judgment Value

Malfunction Criteria	Threshold Value
Battery voltage	≥ 10.9 V
Engine coolant temperature at engine starting	$< 55^{\circ}\text{C}$ (131°F)
Engine coolant temperature	$< 75^{\circ}\text{C}$ (167°F)
(Estimated – measured) Engine coolant temperature	$> 30^{\circ}\text{C}$ (54°F)
Vehicle speed	≥ 30 km/h (19 MPH)
Estimated coolant temperature	$\geq 75^{\circ}\text{C}$ (167°F)
Estimate ambient temperature	$\geq -7^{\circ}\text{C}$ (19°F)

Time Needed for Diagnosis: Not fixed

Malfunction Indicator Light Illumination: Illuminates when malfunction occurs in 2 continuous driving cycles.

Normality Judgment

Judge as OK and clear the NG when the malfunction criteria below are met.

Judgment Value

Malfunction Criteria	Threshold Value
Battery voltage	≥ 10.9 V
Engine coolant temperature at engine starting	$< 55^{\circ}\text{C}$ (131°F)
Engine coolant temperature	$\geq 75^{\circ}\text{C}$ (167°F)
(Estimated – measured) Engine coolant temperature	$\leq 30^{\circ}\text{C}$ (54°F)

6. DTC CLEAR CONDITION

- When the OK idling cycle is completed 40 times in a row
- When “Clear Memory” is performed

7. MALFUNCTION INDICATOR LIGHT CLEAR CONDITION

- When the OK driving cycle is completed 3 times in a row
- When “Clear Memory” is performed

8. FAIL SAFE

None

9. ECM OPERATION AT DTC SETTING

- Memorize the freeze frame data. (For test mode \$02)
- Memorize the diagnostic value and trouble standard value. (For test mode \$06)

AB:DTC P0131 O2 SENSOR CIRCUIT LOW VOLTAGE (BANK 1 SENSOR 1)

1. OUTLINE OF DIAGNOSIS

Detect the open or short circuit of sensor.

Judge as NG when the element applied voltage is out of range, or the element current is out of range.

2. COMPONENT DESCRIPTION

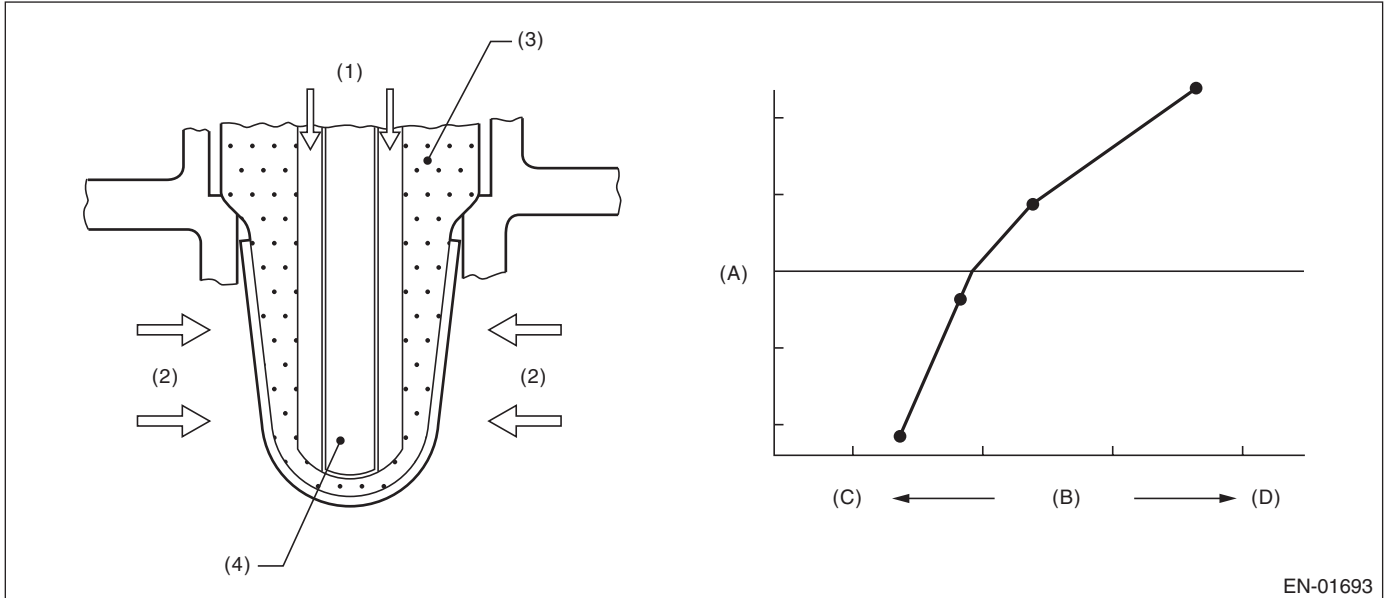

EN-01693

- | | |
|----------------------|-------------------------|
| (1) Atmosphere | (A) Electromotive force |
| (2) Exhaust gas | (B) Air fuel ratio |
| (3) ZrO ₂ | (C) Lean |
| (4) Ceramic heater | (D) Rich |

3. ENABLE CONDITION

Secondary Parameters	Enable Conditions
Battery voltage	≥ 10.9 V

4. GENERAL DRIVING CYCLE

Always perform the diagnosis continuously.

5. DIAGNOSTIC METHOD

Judge as NG when the continuous time of meeting any one of the malfunction criteria below is more than 1 second.

Judgment Value

Malfunction Criteria	Threshold Value
Input voltage	< 1.8 V
Input current	< -0.005 A

Time Needed for Diagnosis: 1 second

Malfunction Indicator Light Illumination: Illuminates as soon as a malfunction occurs.

6. DTC CLEAR CONDITION

- When the OK idling cycle is completed 40 times in a row
- When "Clear Memory" is performed

Diagnostic Trouble Code (DTC) Detecting Criteria

GENERAL DESCRIPTION

7. MALFUNCTION INDICATOR LIGHT CLEAR CONDITION

- When the OK driving cycle is completed 3 times in a row
- When “Clear Memory” is performed

8. FAIL SAFE

- Front oxygen (A/F) sensor heater control: Not allowed to apply current to the heater.
- A/F main learning: Not allowed to calculate the A/F main learning compensation factor.
- A/F sub learning: Not allowed to calculate the A/F sub learning compensation factor.
- Purge control: Not allowed to purge.

9. ECM OPERATION AT DTC SETTING

Memorize the freeze frame data. (For test mode \$02)

AC:DTC P0132 O2 SENSOR CIRCUIT HIGH VOLTAGE (BANK 1 SENSOR 1)

1. OUTLINE OF DIAGNOSIS

Detect the open or short circuit of sensor.

Judge as NG when the element applied voltage is out of range, or the element current is out of range.

2. COMPONENT DESCRIPTION

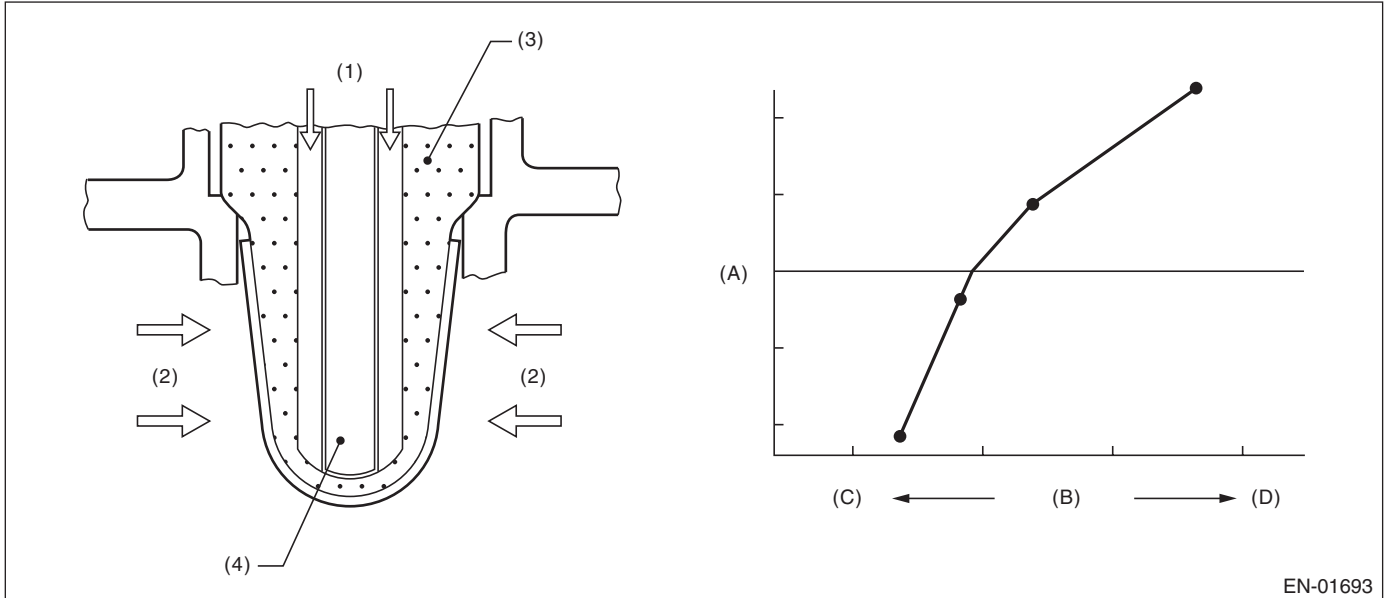

EN-01693

- | | |
|----------------------|-------------------------|
| (1) Atmosphere | (A) Electromotive force |
| (2) Exhaust gas | (B) Air fuel ratio |
| (3) ZrO ₂ | (C) Lean |
| (4) Ceramic heater | (D) Rich |

3. ENABLE CONDITION

Secondary Parameters	Enable Conditions
Battery voltage	≥ 10.9 V

4. GENERAL DRIVING CYCLE

Always perform the diagnosis continuously.

5. DIAGNOSTIC METHOD

Judge as NG when the continuous time of meeting any one of the malfunction criteria below is more than 1 second.

Judgment Value

Malfunction Criteria	Threshold Value
Input voltage	≥ 3.8 V
Input current	≥ 0.005 A

Time Needed for Diagnosis: 1 second

Malfunction Indicator Light Illumination: Illuminates as soon as a malfunction occurs.

6. DTC CLEAR CONDITION

- When the OK idling cycle is completed 40 times in a row
- When "Clear Memory" is performed

Diagnostic Trouble Code (DTC) Detecting Criteria

GENERAL DESCRIPTION

7. MALFUNCTION INDICATOR LIGHT CLEAR CONDITION

- When the OK driving cycle is completed 3 times in a row
- When “Clear Memory” is performed

8. FAIL SAFE

- Front oxygen (A/F) sensor heater control: Not allowed to apply current to the heater.
- A/F main learning: Not allowed to calculate the A/F main learning compensation factor.
- A/F sub learning: Not allowed to calculate the A/F sub learning compensation factor.
- Purge control: Not allowed to purge.

9. ECM OPERATION AT DTC SETTING

Memorize the freeze frame data. (For test mode \$02)

AD:DTC P0133 O2 SENSOR CIRCUIT SLOW RESPONSE (BANK 1 SENSOR 1)

1. OUTLINE OF DIAGNOSIS

Detect the slow response of front oxygen (A/F) sensor.

Front oxygen (A/F) sensor cover has some ventilation holes for exhaust gas. Clogged ventilation holes are diagnosed.

When the holes are clogged, the A/F output variation becomes slow compared with the actual A/F variation because oxygen which reaches the zirconia layer is insufficient. Therefore, if the sensor cover holes are clogged, the rich to lean judgment in the ECM is delayed when the change from rich to lean occurs.

Judge as NG when the actual movement in comparison to the ECM control amount is slow.

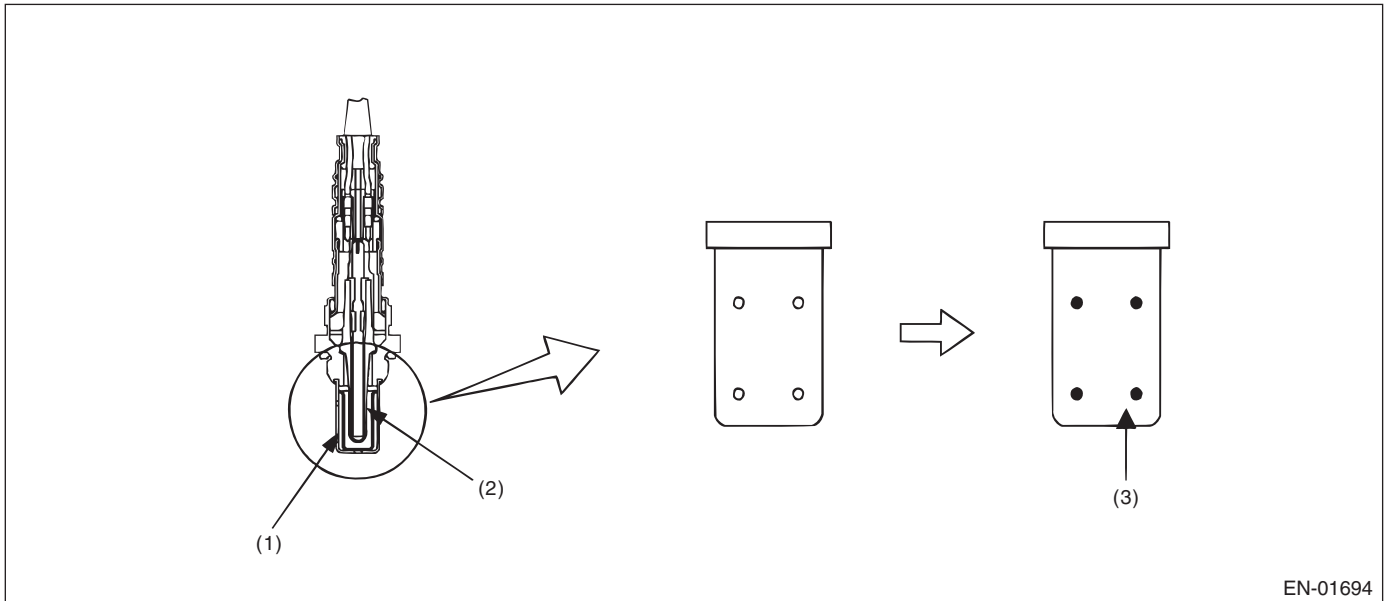

EN-01694

(1) Cover

(2) Zirconia

(3) Clogging

2. COMPONENT DESCRIPTION

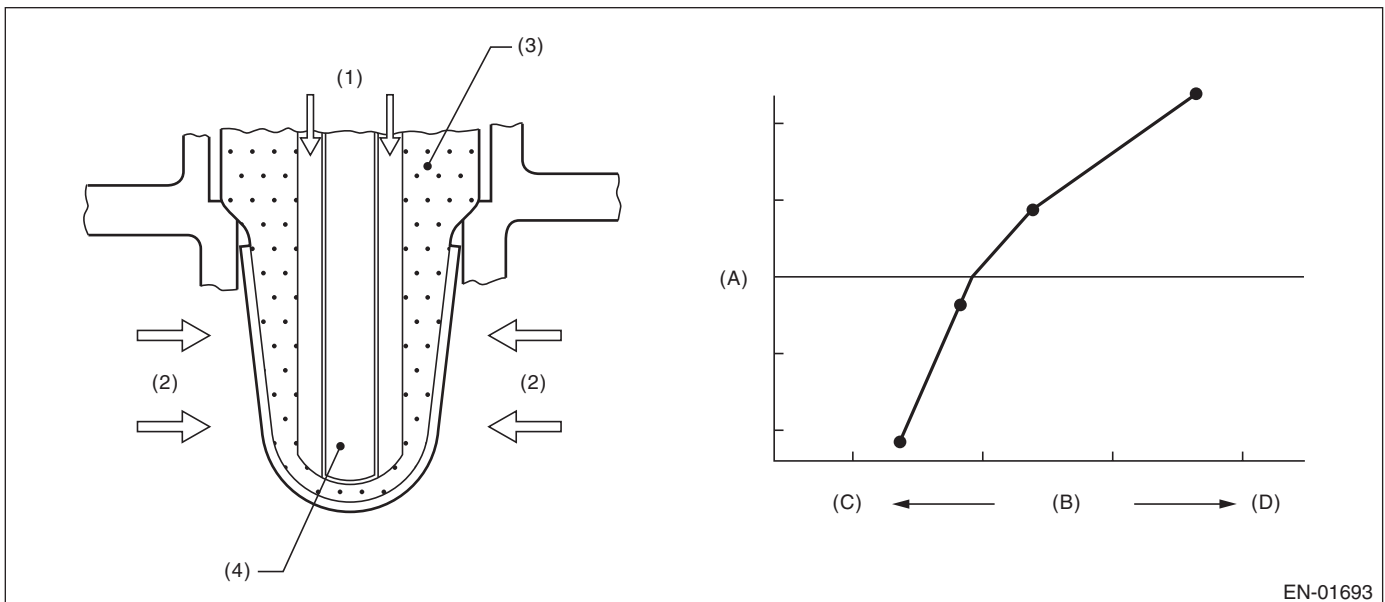

EN-01693

(1) Atmosphere

(2) Exhaust gas

(3) ZrO_2

(4) Ceramic heater

(A) Electromotive force

(B) Air fuel ratio

(C) Lean

(D) Rich

Diagnostic Trouble Code (DTC) Detecting Criteria

GENERAL DESCRIPTION

3. ENABLE CONDITION

Secondary Parameters	Enable Conditions
All secondary parameters enable conditions	1 second or more
Battery voltage	> 10.9 V
Atmospheric pressure	> 75.1 kPa (563 mmHg, 22.2 inHg)
Closed loop control with main feedback	Operating
Front oxygen (A/F) sensor impedance	0 — 50 Ω
After engine starting	120 seconds or more
Engine coolant temperature	≥ 75°C (167°F)
Engine speed	1000 — 3200 rpm
Vehicle speed	10 — 120 km/h (6 — 75 MPH)
Amount of intake air	10 — 40 g (0.35 — 1.41 oz)/s
Engine load change during 0.5 engine revs.	≤ 0.02 g (0.001 oz)/rev
Learning value of EVAP conc. during purge	≤ 0.2
Total time of operating canister purge	20 seconds or more

4. GENERAL DRIVING CYCLE

Perform diagnosis only once at a constant speed of 10 to 120 km/h (6 to 75 MPH) after 120 seconds or more have passed after the engine starting.

5. DIAGNOSTIC METHOD

Calculate faf difference every 128 milliseconds, and the λ value difference. Calculate the diagnostic value after calculating for 210 seconds.

Judge as NG when the malfunction criteria below are met. Judge as OK and clear the NG when the malfunction criteria below are not met.

Judgment Value

Malfunction Criteria	Threshold Value
$\text{para}fca = \text{td}2faf / \text{td}2lmd$ where, $\text{td}2faf (N) = \text{td}2faf (n-1) + d2faf (n) $ $\text{td}2lmd (N) = \text{td}2lmd (n-1) + d2lmd (n) $ add up to a total of 210 seconds $d2faf (n) = (faf (n) - faf (n-1)) - (faf (n-1) - faf (n-2))$ $d2lmd (n) = (lmd (n) - lmd (n-1)) - (lmd (n-1) - lmd (n-2))$ faf = main feedback compensation coefficient every 128 milliseconds lmd = output lambda every 128 milliseconds	≥ 0.44

Time Needed for Diagnosis: 210 seconds

Malfunction Indicator Light Illumination: Illuminates when malfunction occurs in 2 continuous driving cycles.

6. DTC CLEAR CONDITION

- When the OK idling cycle is completed 40 times in a row
- When "Clear Memory" is performed

Diagnostic Trouble Code (DTC) Detecting Criteria

GENERAL DESCRIPTION

7. MALFUNCTION INDICATOR LIGHT CLEAR CONDITION

- When the OK driving cycle is completed 3 times in a row
- When “Clear Memory” is performed

8. FAIL SAFE

- Front oxygen (A/F) sensor main learning compensation: Not allowed to calculate.
- A/F sensor sub learning compensation: Not allowed to calculate.
- Purge control: Not allowed to purge.

9. ECM OPERATION AT DTC SETTING

- Memorize the freeze frame data. (For test mode \$02)
- Memorize the diagnostic value and trouble standard value. (For test mode \$06)

Diagnostic Trouble Code (DTC) Detecting Criteria

GENERAL DESCRIPTION

AE:DTC P0134 O2 SENSOR CIRCUIT NO ACTIVITY DETECTED (BANK 1 SENSOR 1)

1. OUTLINE OF DIAGNOSIS

Detect open circuits of the sensor.

Judge as NG when the impedance of the element is large.

2. COMPONENT DESCRIPTION

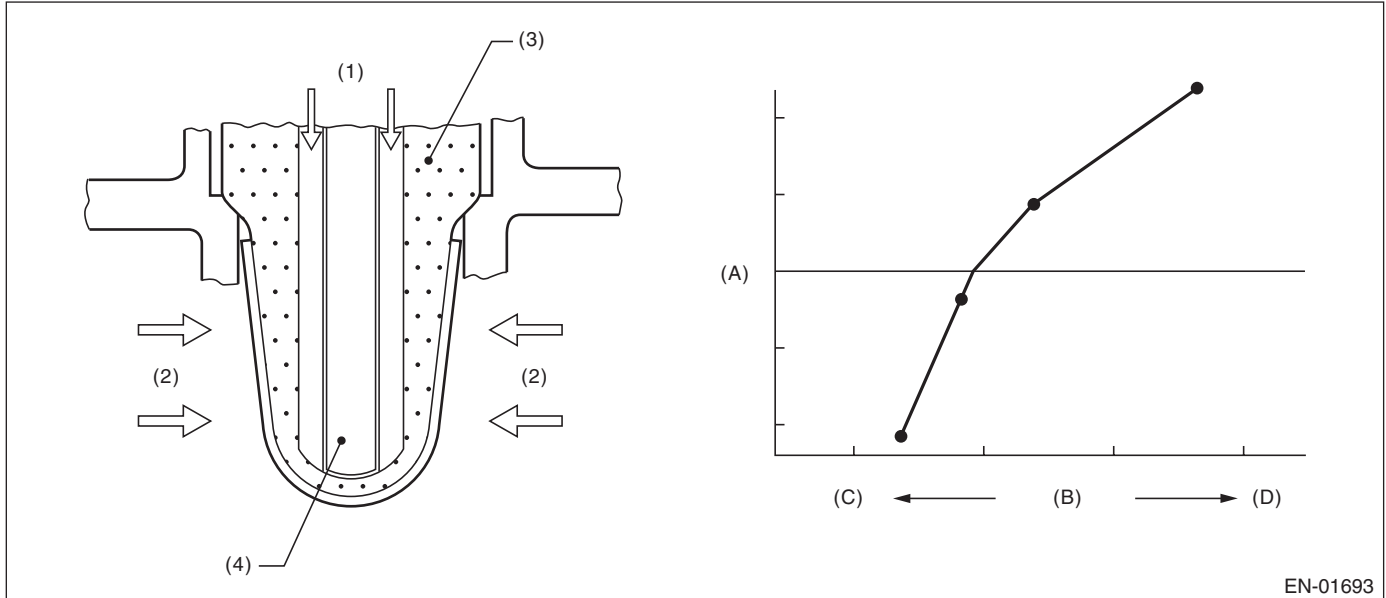

EN-01693

- | | |
|----------------------|-------------------------|
| (1) Atmosphere | (A) Electromotive force |
| (2) Exhaust gas | (B) Air fuel ratio |
| (3) ZrO ₂ | (C) Lean |
| (4) Ceramic heater | (D) Rich |

3. ENABLE CONDITION

Secondary Parameters	Enable Conditions
None	

4. GENERAL DRIVING CYCLE

Always perform the diagnosis continuously.

5. DIAGNOSTIC METHOD

Judge as NG when the continuous time of meeting the malfunction criteria below becomes more than 5 seconds.

Judgment Value

Malfunction Criteria	Threshold Value
Battery voltage	≥ 10.9 V
Time of heater duty ≥ 70%	≥ 30 sec.
Front oxygen (A/F) sensor impedance	≥ 500 Ω

Time Needed for Diagnosis: 5 seconds

Malfunction Indicator Light Illumination: Illuminates as soon as a malfunction occurs.

6. DTC CLEAR CONDITION

- When the OK idling cycle is completed 40 times in a row
- When "Clear Memory" is performed

Diagnostic Trouble Code (DTC) Detecting Criteria

GENERAL DESCRIPTION

7. MALFUNCTION INDICATOR LIGHT CLEAR CONDITION

- When the OK driving cycle is completed 3 times in a row
- When “Clear Memory” is performed

8. FAIL SAFE

- Front oxygen (A/F) sensor heater control: Not allowed to apply current to the heater.
- A/F main learning: Not allowed to calculate the A/F main learning compensation factor.
- A/F sub learning: Not allowed to calculate the A/F sub learning compensation factor.
- Purge control: Not allowed to purge.

9. ECM OPERATION AT DTC SETTING

Memorize the freeze frame data. (For test mode \$02)

Diagnostic Trouble Code (DTC) Detecting Criteria

GENERAL DESCRIPTION

AF:DTC P0137 O2 SENSOR CIRCUIT LOW VOLTAGE (BANK 1 SENSOR 2)

1. OUTLINE OF DIAGNOSIS

Detect the continuity NG of oxygen sensor. If the oxygen sensor voltage reading is not within the probable range considering the operating conditions, judge as NG.

2. COMPONENT DESCRIPTION

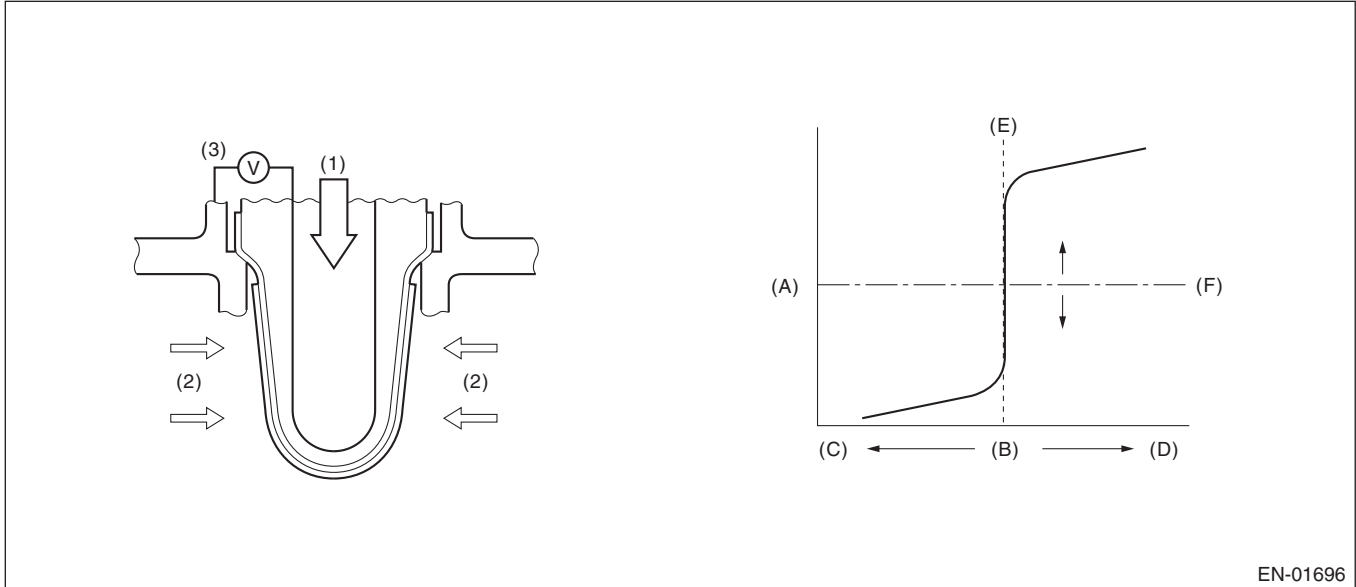

EN-01696

(A) Electromotive force

(B) Air fuel ratio

(1) Atmosphere

(C) Rich

(D) Lean

(2) Exhaust gas

(E) Theoretical air fuel ratio

(F) Comparative voltage

(3) Electromotive force

Diagnostic Trouble Code (DTC) Detecting Criteria

GENERAL DESCRIPTION

3. ENABLE CONDITION

Used only for abnormality judgment

Secondary Parameters	Enable Conditions
High side	
Secondary air injection system	Not in operation
Closed loop control with the oxygen sensor	In operation
Misfire detection during 200 revs.	< 5 times
Front oxygen (A/F) sensor compensation coefficient	Not in limit value
Battery voltage	> 10.9 V
Low side 1	
Secondary air injection system	Not in operation
Closed loop control with the oxygen sensor	In operation
Misfire detection during 200 revs.	< 5 times
Front oxygen (A/F) sensor compensation coefficient	Not in limit value
Battery voltage	> 10.9 V
Amount of intake air	≥ 10 g/second
Low side 2	
Secondary air injection system	Not in operation
Closed loop control with the oxygen sensor	In operation
Misfire detection during 200 revs.	< 5 times
Front oxygen (A/F) sensor compensation coefficient	Not in limit value
Battery voltage	> 10.9 V
Amount of intake air	< 10 g/second
Current continuation time of the rear oxygen sensor heater	30 seconds or more
Low side 3	
Secondary air injection system	Not in operation
Closed loop control with the oxygen sensor	In operation
Misfire detection during 200 revs.	< 5 times
Front oxygen (A/F) sensor compensation coefficient	Not in limit value
Battery voltage	> 10.9 V
Amount of intake air	< 10 g/second
Current continuation time of the rear oxygen sensor heater	30 seconds or more
Fuel cut	Experienced

Used only for normality judgment

Secondary Parameters	Enable Condition
Secondary air injection system	Not in operation
Closed loop control with the oxygen sensor	In operation
Misfire detection during 200 revs.	< 5 times
Front oxygen (A/F) sensor compensation coefficient	Not in limit value
Battery voltage	> 10.9 V

Diagnostic Trouble Code (DTC) Detecting Criteria

GENERAL DESCRIPTION

4. GENERAL DRIVING CYCLE

After starting the engine, perform the diagnosis in series while the engine is in a constant operating condition.

5. DIAGNOSTIC METHOD

Abnormality Judgment

Judge as NG if the continuous time when the following conditions are established exceeds the predetermined time, and judge as OK if it doesn't.

Judgment Value

Malfunction Criteria	Threshold Value	DTC
High side Maximum output voltage without continuity	≥ 1200 mV	P0138
Low side Minimum output voltage without continuity	< 30 mV	P0137

Time Needed for Diagnosis

High side: 2.5 seconds

Low side 1: 20 seconds

Low side 2: 40 seconds

Low side 3: Value from Map

Map

Fuel Cut Time (Seconds)	Time Needed for Diagnosis (Seconds)
0	40
2	40
10	60

Malfunction Indicator Light Illumination: Illuminates when malfunction occurs in 2 continuous driving cycles.

6. DTC CLEAR CONDITION

- When the OK idling cycle is completed 40 times in a row
- When "Clear Memory" is performed

7. MALFUNCTION INDICATOR LIGHT CLEAR CONDITION

- When the OK driving cycle is completed 3 times in a row
- When "Clear Memory" is performed

8. FAIL SAFE

Sub feedback control: Not allowed.

9. ECM OPERATION AT DTC SETTING

Memorize the freeze frame data. (For test mode \$02)

Diagnostic Trouble Code (DTC) Detecting Criteria

GENERAL DESCRIPTION

AG:DTC P0138 O2 SENSOR CIRCUIT HIGH VOLTAGE (BANK 1 SENSOR 2)

NOTE:

For the detection conditions, refer to DTC P0137. <Ref. to GD(H4SO)-66, DTC P0137 O2 SENSOR CIRCUIT LOW VOLTAGE (BANK 1 SENSOR 2), Diagnostic Trouble Code (DTC) Detecting Criteria.>

Diagnostic Trouble Code (DTC) Detecting Criteria

GENERAL DESCRIPTION

AH:DTC P0139 O2 SENSOR CIRCUIT SLOW RESPONSE (BANK 1 SENSOR 2)

1. OUTLINE OF DIAGNOSIS

Detect the slow response of the oxygen sensor.

Judge as NG if either the rich to lean response diagnosis or lean to rich response diagnosis is NG, and judge as OK if both are OK.

[Rich → lean response diagnosis]

1. Measure the response time for oxygen sensor output changes when the A/F ratio changes to rich to lean. If the measured response time is larger than the threshold value, it is NG. If it is smaller, it is OK.

2. Judge as NG when the oxygen sensor voltage is large (rich) when recovering from a deceleration fuel cut.

[Lean → rich response diagnosis]

1. Measure the response time for oxygen sensor output changes when the A/F ratio changes to lean to rich. If the measured response time is larger than the threshold value, it is NG.

2. Judge as NG when the oxygen sensor voltage remains small when recovering from a deceleration fuel cut.

DIAGNOSTIC METHOD

Measure the response time of the output change of the oxygen sensor when the A/F ratio changes to rich to lean. And judge as NG when the measured response time is larger than the threshold value.

2. COMPONENT DESCRIPTION

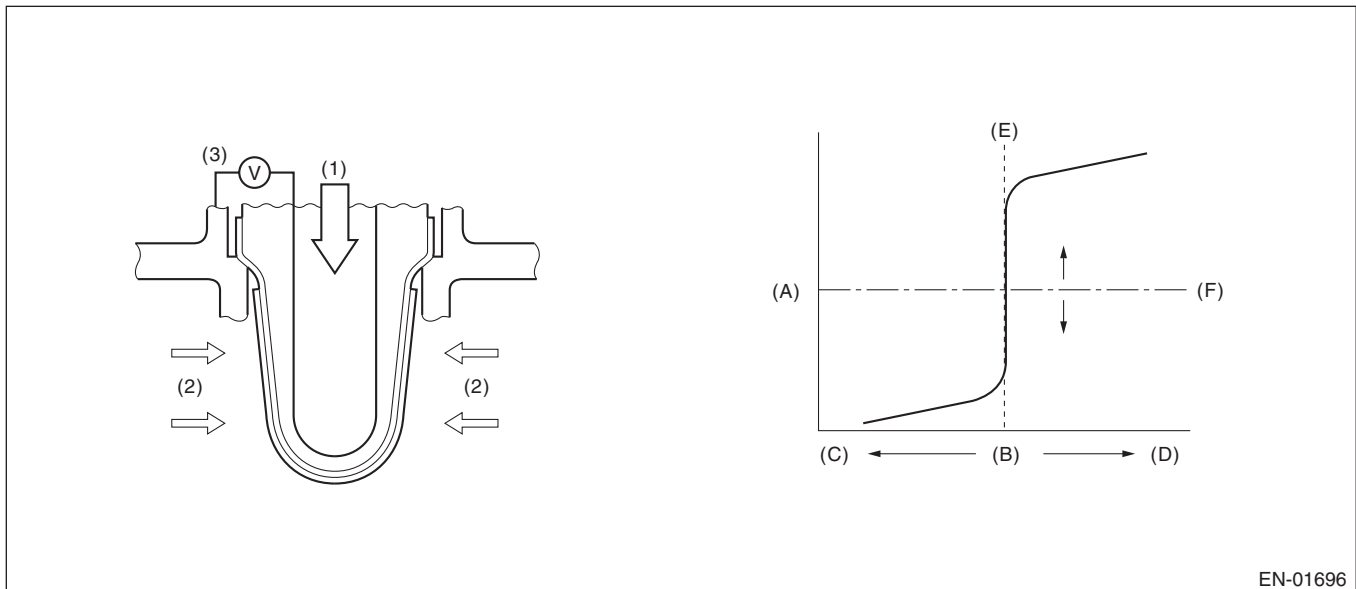

EN-01696

- (1) Atmosphere
- (2) Exhaust gas
- (3) Electromotive force

- (A) Electromotive force
- (B) Air fuel ratio
- (C) Rich

- (D) Lean
- (E) Theoretical air fuel ratio
- (F) Comparative voltage

3. ENABLE CONDITION

- Rich → lean response diagnosis

Secondary Parameters	Enable Condition
Battery voltage	> 10.9 V
A/F sub feedback control condition	Completed
Deceleration fuel cut time is 6 seconds or more.	Experienced
After fuel cut	≥ 2 sec.
Rear oxygen heater current calculation time	≥ 60 sec.
Rear oxygen heater current continuous time	≥ 30 sec.
Catalyst warm-up counter (U5 model)	≥ 9000 times
Estimated temperature in catalyst layer (Except for U5 model)	≥ 400°C (752°F)

Diagnostic Trouble Code (DTC) Detecting Criteria

GENERAL DESCRIPTION

4. GENERAL DRIVING CYCLE

Perform the diagnosis only once when deceleration fuel cut occurs after rapid acceleration. (Pay attention to the oxygen sensor voltage to decide on the timing of the deceleration.)

5. DIAGNOSTIC METHOD

When the oxygen sensor output voltage changes from 0.55 V (rich) to 0.15 V (lean), calculate the minimum response time for output change between 0.5 V and 0.2 V for the judgment criteria.

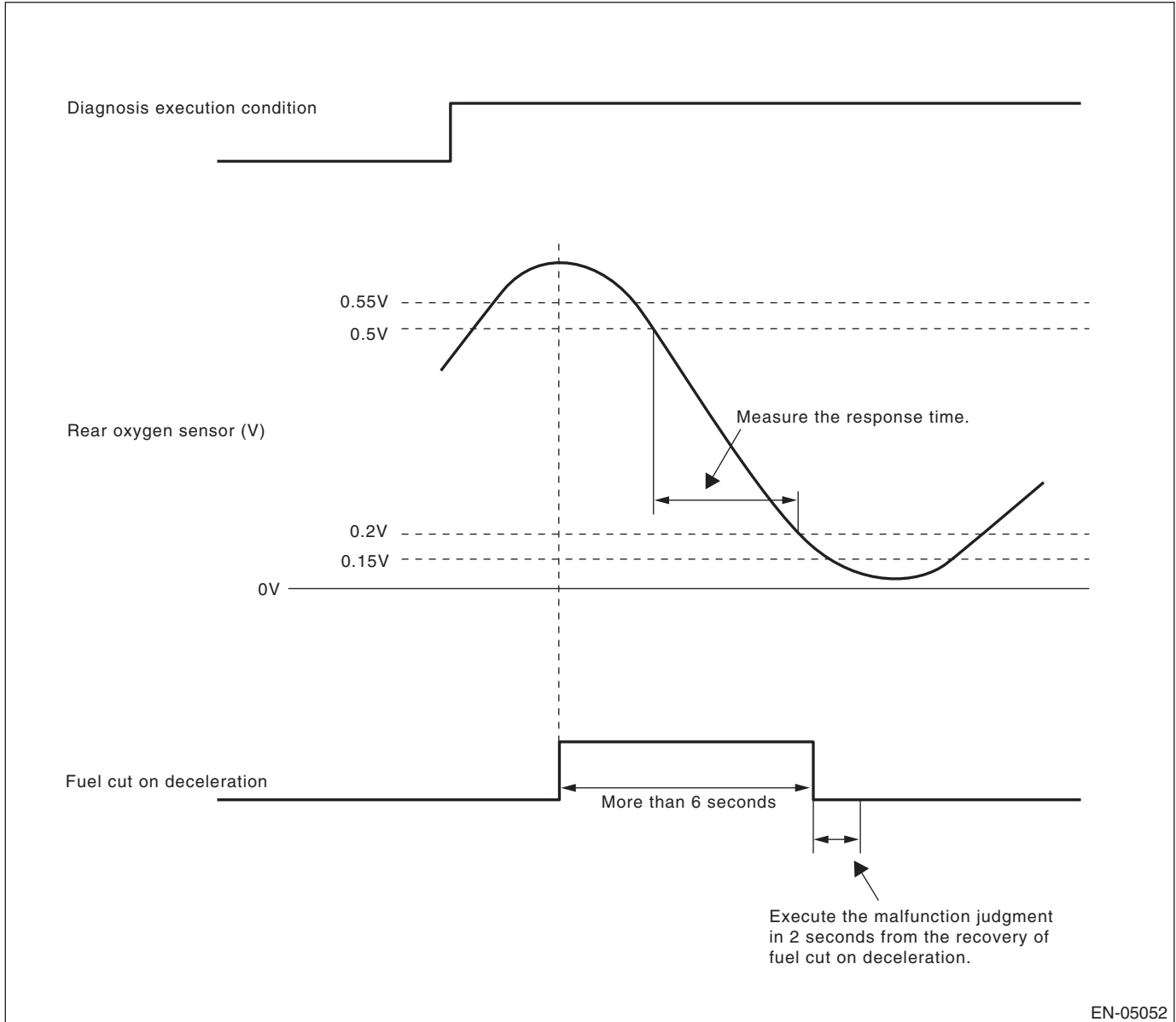

Abnormality Judgment

1. Judge as NG when the judgment value is larger than the threshold value after deceleration fuel cut. Response time (diagnosis value) > threshold value → abnormal

NOTE:

Variation time of rear oxygen sensor output voltage is short during fuel shut-off in deceleration. Carry out the NG judgment only after the fuel shut-off in deceleration. Even without deceleration fuel cut, judge as OK if the value is below the threshold.

When the deceleration fuel cut time is more than 6 seconds, judge as NG if the following criteria are met 2 seconds after recovering from the deceleration fuel cut.

Diagnostic Trouble Code (DTC) Detecting Criteria

GENERAL DESCRIPTION

2. Judge as NG when the oxygen sensor voltage at recovery from a deceleration fuel cut is large. If the fuel cut time in a deceleration fuel cut is long (more than 6 s), and even after recovering from a deceleration fuel cut, the oxygen sensor voltage is high (0.55 V or more), judge as NG.

Judgment Value

Malfunction Criteria	Threshold Value
Shortest time change from rich (0.5 V O ₂ output) to lean (0.2 V) if voltage reduces from 0.55 V to 0.15 V.	> 0.491 sec.
Time at over 0.55 V	> 2 sec.

Time Needed for Diagnosis: 1 time

Malfunction Indicator Light Illumination: Illuminates when malfunction occurs in 2 continuous driving cycles.

Normality Judgment

1. Regardless of a deceleration fuel cut, if the response time (diagnosis value) when the oxygen sensor voltage has changed from rich to lean is shorter than the threshold value (judgment value), judge as a normal condition.

Response time (diagnosis value) ≤ threshold value → normal

2. Do not judge as a normal condition.

Judge as OK when the criteria below are met.

Judgment Value

Malfunction Criteria	Threshold Value
Shortest time change from rich (0.5 V O ₂ output) to lean (0.2 V) if voltage reduces from 0.55 V to 0.15 V.	≤ 0.491 sec.

6. DTC CLEAR CONDITION

- When the OK idling cycle is completed 40 times in a row
- When "Clear Memory" is performed

7. MALFUNCTION INDICATOR LIGHT CLEAR CONDITION

- When the OK driving cycle is completed 3 times in a row
- When "Clear Memory" is performed

8. FAIL SAFE

Sub feedback control: Not allowed.

9. ECM OPERATION AT DTC SETTING

- Memorize the freeze frame data. (For test mode \$02)
- Memorize the diagnostic value and trouble standard value. (For test mode \$06)

10. ENABLE CONDITION

- Lean → rich response diagnosis

Secondary Parameters	Enable Conditions
Battery voltage	> 10.9 V
A/F main feedback control condition	Completed
Deceleration fuel cut ≥ 6 seconds	Experienced
After fuel cut	≥ 2 sec.

11. GENERAL DRIVING CYCLE

Perform the diagnosis only once when deceleration fuel cut occurs after rapid acceleration. (Pay attention to the oxygen sensor voltage to decide on the timing of the deceleration.)

Diagnostic Trouble Code (DTC) Detecting Criteria

GENERAL DESCRIPTION

12. DIAGNOSTIC METHOD

Calculate the minimum value of 0.3 V to 0.5 V output change response time when the oxygen sensor output voltage changes from 0.25 V (lean) to 0.55 V (rich).

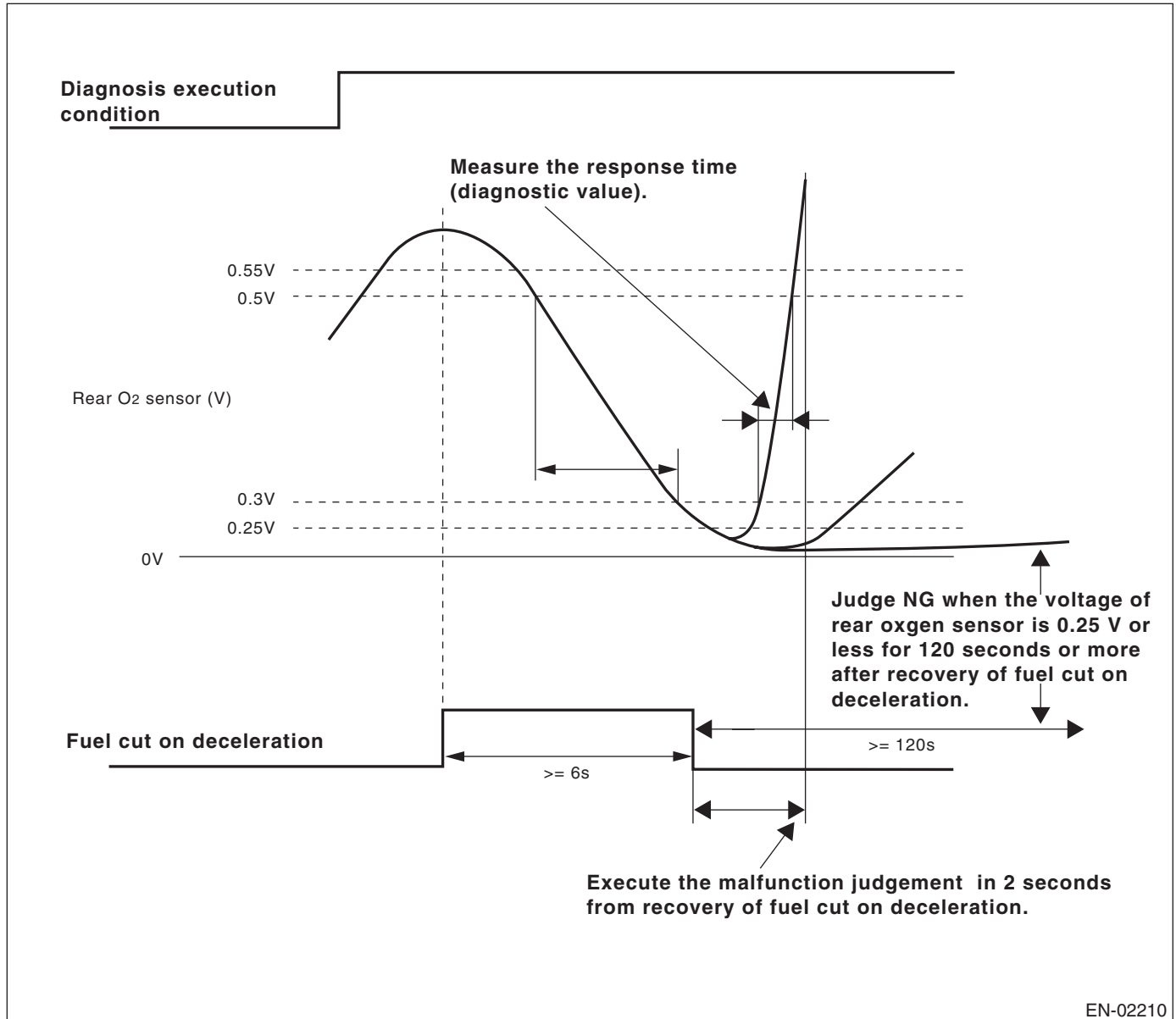

Diagnostic Trouble Code (DTC) Detecting Criteria

GENERAL DESCRIPTION

Abnormality Judgment

1. Judge as NG when the judgment value is larger than the threshold value after deceleration fuel cut.
Response time (diagnostic value) > threshold value → abnormal
2. If the oxygen sensor voltage is small after recovering from a deceleration fuel cut, and remains small, judge as NG.

Judgment Value

Malfunction Criteria	Threshold Value
Shortest time change from lean (0.3 V O ₂ output) to rich (0.5 V) when voltage drops from 0.5 V to 0.25 V.	> 2 sec.
Time at less than 0.25 V	> 120 sec.

Time Needed for Diagnosis: 1 time

Malfunction Indicator Light Illumination: Illuminates when malfunction occurs in 2 continuous driving cycles.

Normality Judgment

1. Regardless of a deceleration fuel cut, if the response time (diagnostic value) when the oxygen sensor voltage has changed from rich to lean is shorter than the threshold value (judgment value), judge as normal.
Response time (diagnostic value) ≤ threshold value → normal
2. Normality judgement is not to be performed.
Judge as OK when the criteria below are met.

Judgment Value

Malfunction Criteria	Threshold Value
Shortest time change from lean (0.3 V O ₂ output) to rich (0.5 V) when voltage drops from 0.55 V to 0.25 V.	≤ 2 sec.

13.DTC CLEAR CONDITION

- When the OK idling cycle is completed 40 times in a row
- When “Clear Memory” is performed

14.MALFUNCTION INDICATOR LIGHT CLEAR CONDITION

- When the OK driving cycle is completed 3 times in a row
- When “Clear Memory” is performed

15.FAIL SAFE

Sub feedback control: Not allowed.

16.ECM OPERATION AT DTC SETTING

- Memorize the freeze frame data. (For test mode \$02)
- Memorize the diagnostic value and trouble standard value. (For test mode \$06)

Diagnostic Trouble Code (DTC) Detecting Criteria

GENERAL DESCRIPTION

AI: DTC P0140 O2 SENSOR CIRCUIT NO ACTIVITY DETECTED (BANK 1 SENSOR 2)

1. OUTLINE OF DIAGNOSIS

Detect abnormalities in the rear oxygen sensor output property.

When looking at the intake air amount, coolant temperature, main feedback control, deceleration fuel cut and other operating conditions, even though the rear oxygen sensor voltage should be moving under those conditions, if the voltage is low, this is judged as a Low side NG. If the voltage is high, it is judged as a High side NG.

When either Low side or High side is NG, judged as rear oxygen sensor property NG.

2. ENABLE CONDITION

Secondary Parameters	Enable Conditions
Engine coolant temperature	$\geq 75^{\circ}\text{C}$ (167°F)
Target output voltage of the rear oxygen sensor	$\geq 0.6\text{ V}$
Air intake amount	10 g (0.35 oz)/seconds or more
Battery voltage	$> 10.9\text{ V}$
Closed loop with the oxygen sensor	In operation
Misfire detection during 200 revs.	5 times or less
Front oxygen (A/F) sensor compensation coefficient	Not in limit value
Deceleration fuel cut of 5 seconds or more.	Experienced

3. GENERAL DRIVING CYCLE

Perform the diagnosis only once after idling.

4. DIAGNOSTIC METHOD

Abnormality Judgment

When one of the following conditions is established, judged as NG.

Judgment Value

Malfunction Criteria	Threshold Value
Maximum output voltage low side diagnosis	$< 0.55\text{ V}$
Minimum output voltage high side diagnosis	$> 0.25\text{ V}$

Time Needed for Diagnosis: 200 seconds

Malfunction Indicator Light Illumination: Illuminates when malfunction occurs in 2 continuous driving cycles.

Normality Judgment

When the following conditions are established, judged as OK.

Judgment Value

Malfunction Criteria	Threshold Value
Maximum output voltage low side diagnosis	$\geq 0.55\text{ V}$
Minimum output voltage high side diagnosis	$\leq 0.25\text{ V}$

Diagnostic Trouble Code (DTC) Detecting Criteria

GENERAL DESCRIPTION

5. DTC CLEAR CONDITION

- When the OK idling cycle is completed 40 times in a row
- When "Clear Memory" is performed

6. MALFUNCTION INDICATOR LIGHT CLEAR CONDITION

- When the OK driving cycle is completed 3 times in a row
- When "Clear Memory" is performed

7. FAIL SAFE

Sub feedback control: Not allowed.

8. ECM OPERATION AT DTC SETTING

Memorize the freeze frame data. (For test mode \$02)

Diagnostic Trouble Code (DTC) Detecting Criteria

GENERAL DESCRIPTION

AJ:DTC P0171 SYSTEM TOO LEAN (BANK 1)

1. OUTLINE OF DIAGNOSIS

Detect fuel system malfunction by the amount of main feedback control.

DIAGNOSTIC METHOD

Fuel system is diagnosed by comparing the target air fuel ratio calculated by ECM with the actual air fuel ratio measured by sensor.

2. ENABLE CONDITION

- Lean side

Secondary Parameters	Enable Conditions
A/F main learning system	In operation
Engine coolant temperature	$\geq 75^{\circ}\text{C}$ (167°F)
Amount of intake air	\geq Value from Map 5
Intake air change during 0.5 engine revs.	≤ 0.02 g (0.001 oz)/rev

Map 5

Engine speed (rpm)	Idling	650	1000	1500	2000	2500	3000	3500	4000	4500
Measured value (g(oz)/rev)	NA	0.203 (0.0072)	0.183 (0.0065)	0.155 (0.0055)	0.149 (0.0053)	0.157 (0.0055)	0.162 (0.0057)	0.18 (0.0063)	0.193 (0.0068)	0.205 (0.0072)

3. GENERAL DRIVING CYCLE

Perform the diagnosis continuously at idling or at a constant speed after warming up the engine.

Diagnostic Trouble Code (DTC) Detecting Criteria

GENERAL DESCRIPTION

4. DIAGNOSTIC METHOD

Abnormality Judgment

Compare the diagnosed value (fsobd) with the threshold value, and if a condition where the malfunction criteria below are met continues for more than 50 seconds, judge that there is a fault in the fuel system.

Judgment Value

Malfunction Criteria	Threshold Value
$fsobd = (sglmd - tglmda) + faf + flaf$ where, sglmd = measured lambda tglmda = target lambda faf = main feedback compensation coefficient (every 64 milliseconds) flaf = main feedback learning compensation coefficient	$\geq fsobdL1$ See Map 4 fsobdL1 = lean side threshold value of fsobd

Map 4 Threshold value for fuel system malfunction criteria

Amount of air (g(oz)/s)	0 (0)	3.2 (0.113)	6.4 (0.226)	9.6 (0.339)	12.8 (0.451)	16 (0.564)	19.2 (0.677)
fsobdL1 (%)	40	40	33.2	26.5	26.5	26.5	26.5

Time Needed for Diagnosis: 10 seconds \times 5 times

Malfunction Indicator Light Illumination: Illuminates when malfunction occurs in 2 continuous driving cycles.

Normality Judgment

Judge as OK when the malfunction criteria below continue for 10 seconds or more.

Judgment Value

Malfunction Criteria	Threshold Value
$fsobd = (sglmd - tglmda) + faf + flaf$	$< 19\%$

5. DTC CLEAR CONDITION

- When the OK idling cycle is completed 40 times in a row
- When "Clear Memory" is performed

6. MALFUNCTION INDICATOR LIGHT CLEAR CONDITION

- When similar driving conditions are repeated 3 times and the result is OK.
- When "Clear Memory" is performed

7. FAIL SAFE

None

8. ECM OPERATION AT DTC SETTING

Memorize the freeze frame data. (For test mode \$02)

Diagnostic Trouble Code (DTC) Detecting Criteria

GENERAL DESCRIPTION

AK:DTC P0172 SYSTEM TOO RICH (BANK 1)

1. OUTLINE OF DIAGNOSIS

Detect fuel system malfunction by the amount of main feedback control.

DIAGNOSTIC METHOD

Fuel system is diagnosed by comparing the target air fuel ratio calculated by ECM with the actual air fuel ratio measured by sensor.

2. ENABLE CONDITION

Secondary Parameters	Enable Conditions
A/F main learning system	In operation
Engine coolant temperature	$\geq 75^{\circ}\text{C}$ (168°F)
Amount of intake air	\geq Value from Map 5
Intake air change during 0.5 engine revs.	≤ 0.02 g (0.001 oz)/rev
Learning value of EVAP conc. during purge	< 0.1
Cumulative time of canister purge after engine start	20 seconds or more
Continuous period after canister purge starting	30 seconds or more

Map 5

Engine speed (rpm)	Idling	650	1000	1500	2000	2500	3000	3500	4000	4500
Measured value (g(oz)/rev)	NA	0.203 (0.0072)	0.183 (0.0065)	0.155 (0.0055)	0.149 (0.0053)	0.157 (0.0055)	0.162 (0.0057)	0.18 (0.0063)	0.193 (0.0068)	0.205 (0.0072)

3. GENERAL DRIVING CYCLE

Perform the diagnosis continuously at idling or at a constant speed after warming up the engine.

Diagnostic Trouble Code (DTC) Detecting Criteria

GENERAL DESCRIPTION

4. DIAGNOSTIC METHOD

Abnormality Judgment

Compare the diagnosed value (fsobd) with the threshold value, and if a condition where the malfunction criteria below are met continues for more than 50 seconds, judge that there is a fault in the fuel system.

Judgment Value

Malfunction Criteria	Threshold Value
$fsobd = (sglmd - tglmda) + faf + flaf$ where, sglmd = measured lambda tglmda = target lambda faf = main feedback compensation coefficient every 64 milliseconds flaf = main feedback learning compensation coefficient	$\leq fsobdR1$ See Map 4 fsobdR1 = rich side threshold value of fsobd

Map 4 Threshold value for fuel system malfunction criteria

Amount of air (g(oz)/s)	0 (0)	3.2 (0.113)	6.4 (0.226)	9.6 (0.339)	12.8 (0.451)	11.7 (0.413)	19.2 (0.677)
fsobdR1 (%)	-40	-40	-33.2	-26.5	-26.5	-26.5	-26.5

Time Needed for Diagnosis: 10 seconds \times 5 times

Malfunction Indicator Light Illumination: Illuminates when malfunction occurs in 2 continuous driving cycles.

Normality Judgment

Judge as OK when the malfunction criteria below continues for 10 seconds.

Judgment Value

Malfunction Criteria	Threshold Value
$fsobd = (sglmd - tglmda) + faf + flaf$	$\geq -20\%$

5. DTC CLEAR CONDITION

- When the OK idling cycle is completed 40 times in a row
- When "Clear Memory" is performed

6. MALFUNCTION INDICATOR LIGHT CLEAR CONDITION

- When similar driving conditions are repeated 3 times and the result is OK.
- When "Clear Memory" is performed

7. FAIL SAFE

Purge control solenoid valve control: Not allowed to purge.

8. ECM OPERATION AT DTC SETTING

Memorize the freeze frame data. (For test mode \$02)

Diagnostic Trouble Code (DTC) Detecting Criteria

GENERAL DESCRIPTION

AL:DTC P0181 FUEL TEMPERATURE SENSOR "A" CIRCUIT RANGE/ PERFORMANCE

1. OUTLINE OF DIAGNOSIS

Detect faults in the fuel temperature sensor output properties.

Diagnosis is performed in two methods; drift diagnosis and stuck diagnosis. If either is NG, judge as NG. If both are OK, Judge as OK and clear the NG.

DRIFT DIAGNOSIS

Normally fuel temperature is lower than engine coolant temperature. When the fuel temperature becomes higher than the engine coolant temperature, the range is considered to be shifted, and judged as NG.

2. COMPONENT DESCRIPTION

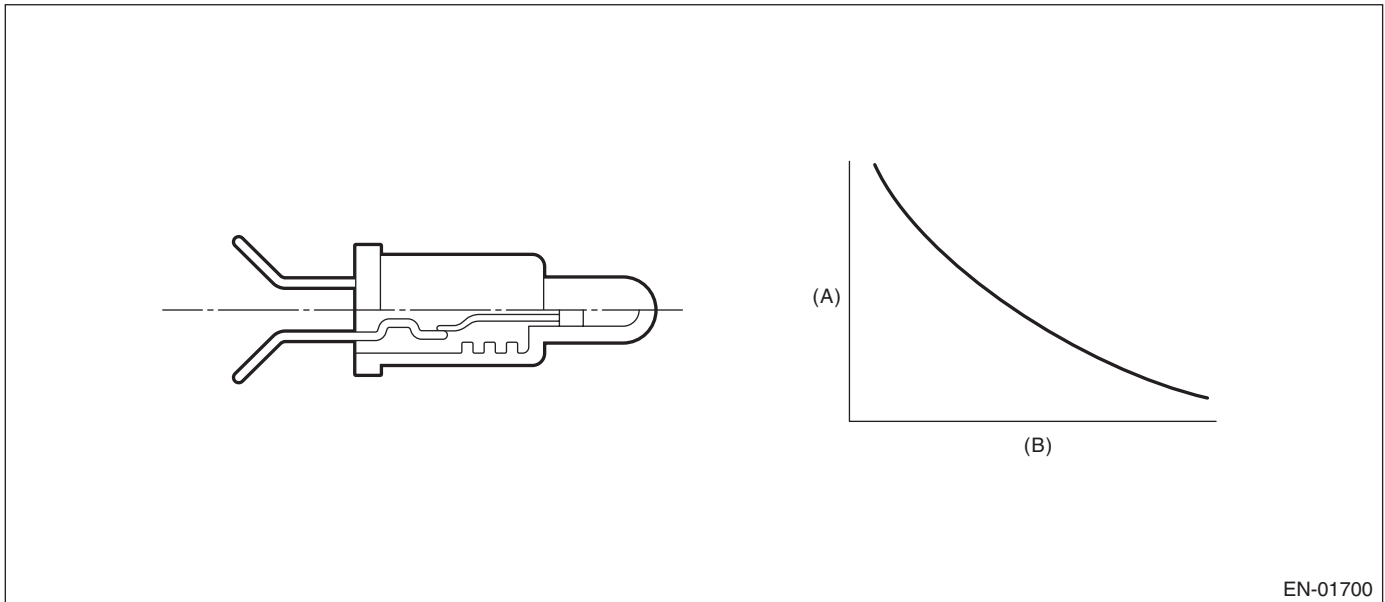

(A) Resistance value (Ω)

(B) Fuel temperature $^{\circ}\text{C}$ ($^{\circ}\text{F}$)

3. ENABLE CONDITION

Secondary Parameters	Enable Conditions
None	

4. GENERAL DRIVING CYCLE

Always perform the diagnosis continuously.

Diagnostic Trouble Code (DTC) Detecting Criteria

GENERAL DESCRIPTION

5. DIAGNOSTIC METHOD

Abnormality Judgment

Judge as NG when the continuous time of meeting the malfunction criteria below becomes 120 seconds or more.

Judgment Value

Malfunction Criteria	Threshold Value
Fuel level	$\geq 9.0 \ell$ (2.38 US gal, 1.98 Imp gal)
After engine starting	20 seconds or more
Engine coolant temperature – engine coolant temperature at engine start	$> 10^{\circ}\text{C}$ (18°F)
Fuel temperature – Engine coolant temperature	$\geq 10^{\circ}\text{C}$ (18°F)
Battery voltage	$> 10.9 \text{ V}$

Time Needed for Diagnosis: 120 seconds

Malfunction Indicator Light Illumination: Illuminates when malfunction occurs in 2 continuous driving cycles.

Normality Judgment

Judge as OK when the criteria below are met.

Judgment Value

Malfunction Criteria	Threshold Value
Fuel level	$\geq 9.0 \ell$ (2.38 US gal, 1.98 Imp gal)
After engine starting	20 seconds or more
Engine coolant temperature – engine coolant temperature at engine start	$> 10^{\circ}\text{C}$ (18°F)
Fuel temperature – Engine coolant temperature	$< 10^{\circ}\text{C}$ (18°F)
Engine coolant temperature	$< 75^{\circ}\text{C}$ (167°F)
Battery voltage	$> 10.9 \text{ V}$

Stuck Diagnosis

As the engine warms up (cumulative amount of intake air after starting is large), if the fuel temperature which should rise does not, determine as being stuck and NG.

6. ENABLE CONDITION

Secondary Parameters	Enable Conditions
After engine starting	20 seconds or more
Battery voltage	$> 10.9 \text{ V}$

7. GENERAL DRIVING CYCLE

Always perform diagnosis after 20 seconds have passed since the engine started.

Diagnostic Trouble Code (DTC) Detecting Criteria

GENERAL DESCRIPTION

8. DIAGNOSTIC METHOD

Abnormality Judgment

Judge as NG when the malfunction criteria below are met.

Judgment Value

Malfunction Criteria	Threshold Value
Accumulated amount of intake air	≥ 551 kg (1215 lb)
Fuel temperature difference between Max. and Min.	< 2°C (3.6°F)

Time Needed for Diagnosis: Undetermined

Malfunction Indicator Light Illumination: Illuminates when malfunction occurs in 2 continuous driving cycles.

Normality Judgment

Judge as OK when the criteria below are met.

Judgment Value

Malfunction Criteria	Threshold Value
Accumulated amount of intake air	≥ 551 kg (1215 lb)
Fuel temperature difference between Max. and Min.	≥ 2°C (3.6°F)

9. DTC CLEAR CONDITION

- When the OK idling cycle is completed 40 times in a row
- When "Clear Memory" is performed

10.MALFUNCTION INDICATOR LIGHT CLEAR CONDITION

- When the OK driving cycle is completed 3 times in a row
- When "Clear Memory" is performed

11.FAIL SAFE

None

12.ECM OPERATION AT DTC SETTING

Memorize the freeze frame data. (For test mode \$02)

Diagnostic Trouble Code (DTC) Detecting Criteria

GENERAL DESCRIPTION

AM:DTC P0182 FUEL TEMPERATURE SENSOR "A" CIRCUIT LOW INPUT

1. OUTLINE OF DIAGNOSIS

Detect the open or short circuit of fuel temperature sensor.
Judge as NG if it is out of specification.

2. COMPONENT DESCRIPTION

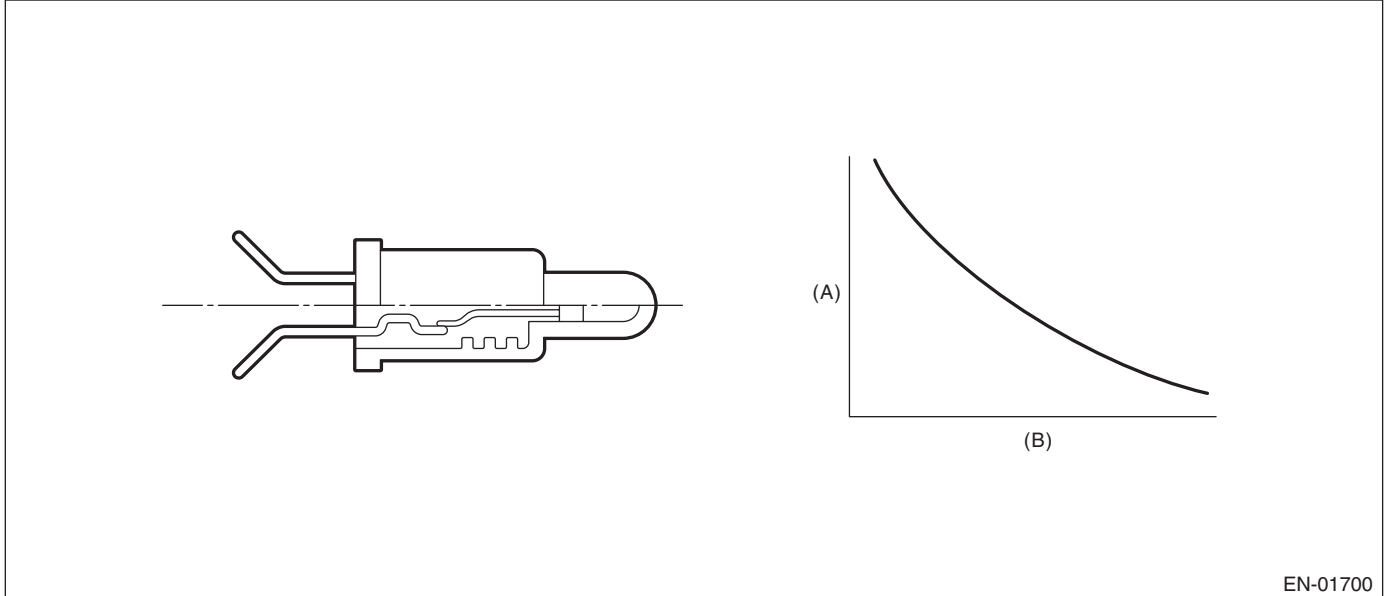

EN-01700

(A) Resistance value (Ω)

(B) Fuel temperature °C (°F)

3. ENABLE CONDITION

Secondary Parameters	Enable Conditions
None	

4. GENERAL DRIVING CYCLE

Always perform the diagnosis continuously.

5. DIAGNOSTIC METHOD

Abnormality Judgment

Judge as NG when the continuous time of meeting the malfunction criteria below becomes 2.5 seconds or more.

Judgment Value

Malfunction Criteria	Threshold Value
Output voltage	< 0.166 V
Battery voltage	≥ 10.9 V

Time Needed for Diagnosis: 2.5 seconds

Malfunction Indicator Light Illumination: Illuminates as soon as a malfunction occurs.

Normality Judgment

Judge as OK and clear the NG when the malfunction criteria below are met.

Judgment Value

Malfunction Criteria	Threshold Value
Output voltage	≥ 0.166 V
Battery voltage	≥ 10.9 V

Diagnostic Trouble Code (DTC) Detecting Criteria

GENERAL DESCRIPTION

6. DTC CLEAR CONDITION

- When the OK idling cycle is completed 40 times in a row
- When "Clear Memory" is performed

7. MALFUNCTION INDICATOR LIGHT CLEAR CONDITION

- When the OK driving cycle is completed 3 times in a row
- When "Clear Memory" is performed

8. FAIL SAFE

None

9. ECM OPERATION AT DTC SETTING

Memorize the freeze frame data. (For test mode \$02)

Diagnostic Trouble Code (DTC) Detecting Criteria

GENERAL DESCRIPTION

AN:DTC P0183 FUEL TEMPERATURE SENSOR “A” CIRCUIT HIGH INPUT

1. OUTLINE OF DIAGNOSIS

Detect the open or short circuit of fuel temperature sensor.
Judge as NG if it is out of specification.

2. COMPONENT DESCRIPTION

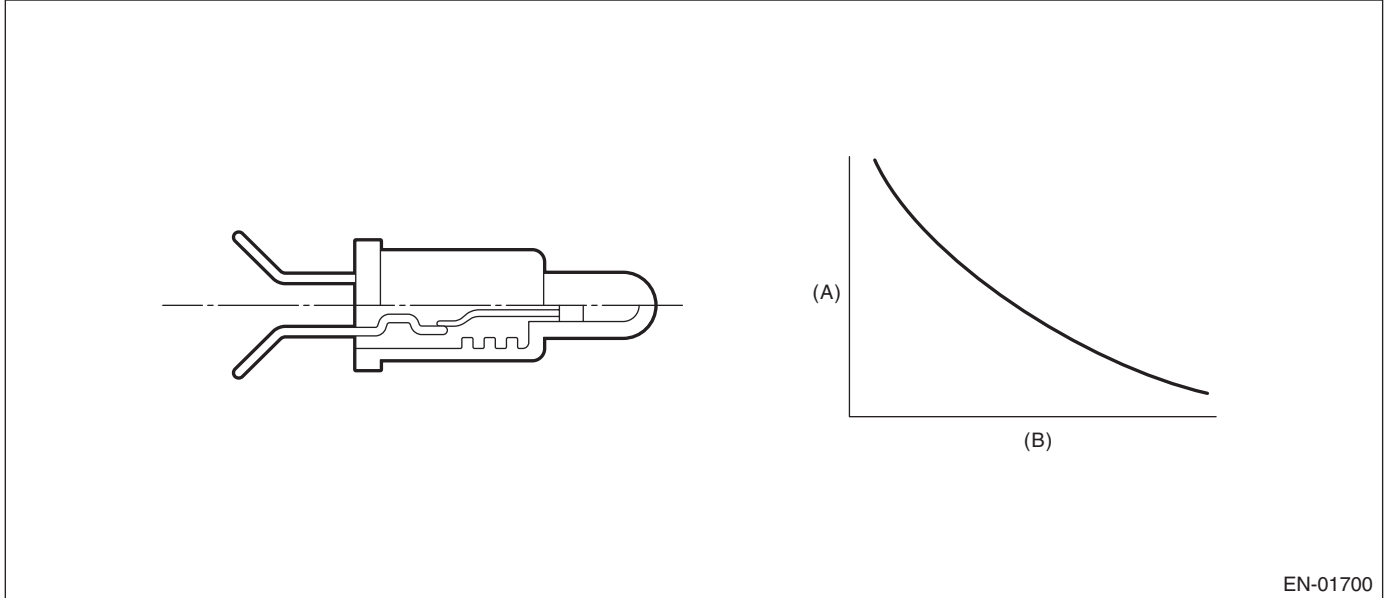

(A) Resistance value (Ω)

(B) Fuel temperature °C (°F)

3. ENABLE CONDITION

Secondary Parameters	Enable Conditions
None	

4. GENERAL DRIVING CYCLE

Always perform the diagnosis continuously.

Diagnostic Trouble Code (DTC) Detecting Criteria

GENERAL DESCRIPTION

5. DIAGNOSTIC METHOD

Abnormality Judgment

Judge as NG when the continuous time of meeting the malfunction criteria below becomes 2.5 seconds or more.

Judgment Value

Malfunction Criteria	Threshold Value
Output voltage	$\geq 4.716 \text{ V}$
Battery voltage	$\geq 10.9 \text{ V}$

Time Needed for Diagnosis: 2.5 seconds

Malfunction Indicator Light Illumination: Illuminates as soon as a malfunction occurs.

Normality Judgment

Judge as OK and clear the NG when the malfunction criteria below are met.

Judgment Value

Malfunction Criteria	Threshold Value
Output voltage	$< 4.716 \text{ V}$
Battery voltage	$\geq 10.9 \text{ V}$

6. DTC CLEAR CONDITION

- When the OK idling cycle is completed 40 times in a row
- When "Clear Memory" is performed

7. MALFUNCTION INDICATOR LIGHT CLEAR CONDITION

- When the OK driving cycle is completed 3 times in a row
- When "Clear Memory" is performed

8. FAIL SAFE

None

9. ECM OPERATION AT DTC SETTING

Memorize the freeze frame data. (For test mode \$02)

Diagnostic Trouble Code (DTC) Detecting Criteria

GENERAL DESCRIPTION

AO:DTC P0196 ENGINE OIL TEMPERATURE SENSOR CIRCUIT RANGE/ PERFORMANCE

1. OUTLINE OF DIAGNOSIS

Detect for abnormal values in the oil temperature sensor output properties.

Judge as NG when the oil temperature does not rise even though the engine is running under a condition where it should rise.

2. ENABLE CONDITION

Secondary Parameters	Enable Conditions
Battery voltage	≥ 10.9 V
Engine speed	500 rpm

3. GENERAL DRIVING CYCLE

Perform the diagnosis continuously after starting the engine.

Diagnostic Trouble Code (DTC) Detecting Criteria

GENERAL DESCRIPTION

4. DIAGNOSTIC METHOD

Abnormality Judgment

When the following conditions are established, judged as NG.

Judgment Value

Malfunction Criteria	Threshold Value
Engine oil temperature	< 15°C (59°F)
After engine start oil temperature sensor characteristic diagnosis timer	≥ Judgment value for after engine start oil temperature sensor characteristic diagnosis timer

After engine start oil temperature sensor characteristic diagnosis timer (timer for diagnosis).

a. Timer stop at fuel cut mode

b. During the driving conditions except a) above, timer counts up.

64 milliseconds + TOILCNT milliseconds (at the time of 64 milliseconds)

Where, TOILCNT is determined as follows.

TOILCNT = 0 (at idle switch ON)

For TOILCNT at Idle switch off, refer to the following table.

		Vehicle speed km/h (MPH)							
		0 (0)	8 (5)	16 (10)	24 (15)	32 (20)	40 (25)	48 (30)	56 (35)
Temperature °C (°F)	-30 (-22)	64 ms	73.2 ms	83.9 ms	96.3 ms	113.2 ms	133.9 ms	160.2 ms	194.6 ms
	-20 (-4)	64 ms	73.3 ms	84 ms	96.6 ms	113.7 ms	135 ms	162 ms	197.4 ms
	-10 (14)	64 ms	73.4 ms	84.2 ms	96.9 ms	114.5 ms	136.4 ms	164.4 ms	201.5 ms
	0 (32)	64 ms	73.5 ms	84.5 ms	97.4 ms	115.6 ms	138.5 ms	168 ms	207.6 ms
	10(50)	102.2 ms	114.8 ms	129.4 ms	146.7 ms	171.7 ms	203.4 ms	245.1 ms	302.1 ms

After engine start oil temperature characteristic diagnosis timer judgment value (t).

$t = 1882940 - 43302 \times T_i$ ($t \geq 1882940$)

T_i = The lowest coolant temperature after starting the engine

Time Needed for Diagnosis: Undetermined

Malfunction Indicator Light Illumination: Illuminates when malfunction occurs in 2 continuous driving cycles.

Normality Judgment

When the following conditions are established, judged as OK.

Judgment Value

Malfunction Criteria	Threshold Value
Engine oil temperature	≥ 15°C (59°F)

5. DTC CLEAR CONDITION

- When the OK idling cycle is completed 40 times in a row
- When "Clear Memory" is performed

6. MALFUNCTION INDICATOR LIGHT CLEAR CONDITION

- When the OK driving cycle is completed 3 times in a row
- When "Clear Memory" is performed

7. FAIL SAFE

Oil temperature sensor process: Engine oil temperature is fixed at 70°C (158°F).

8. ECM OPERATION AT DTC SETTING

Memorize the freeze frame data. (For test mode \$02)

Diagnostic Trouble Code (DTC) Detecting Criteria

GENERAL DESCRIPTION

AP:DTC P0197 ENGINE OIL TEMPERATURE SENSOR LOW

1. OUTLINE OF DIAGNOSIS

Detect the open or short circuit of the oil temperature sensor.
Judge as NG when outside of the possible range.

2. ENABLE CONDITION

Secondary Parameters	Enable Conditions
None	

3. GENERAL DRIVING CYCLE

Always perform the diagnosis continuously.

4. DIAGNOSTIC METHOD

Judge as NG when the continuous time when the following conditions are established is more than 0.5 seconds. Judge as OK and clear the NG when the following conditions are not established.

Judgment Value

Malfunction Criteria	Threshold Value
Output voltage	≤ 0.166 V

Time Needed for Diagnosis: 0.5 seconds

Malfunction Indicator Light Illumination: Illuminates as soon as a malfunction occurs.

5. DTC CLEAR CONDITION

- When the OK idling cycle is completed 40 times in a row
- When "Clear Memory" is performed

6. MALFUNCTION INDICATOR LIGHT CLEAR CONDITION

- When the OK driving cycle is completed 3 times in a row
- When "Clear Memory" is performed

7. FAIL SAFE

Oil temperature sensor process: Engine oil temperature is fixed at 70°C (158°F).

8. ECM OPERATION AT DTC SETTING

Memorize the freeze frame data. (For test mode \$02)

Diagnostic Trouble Code (DTC) Detecting Criteria

GENERAL DESCRIPTION

AQ:DTC P0198 ENGINE OIL TEMPERATURE SENSOR HIGH

1. OUTLINE OF DIAGNOSIS

Detect the open or short circuit of the oil temperature sensor.
Judge as NG when outside of the judgment value.

2. ENABLE CONDITION

Secondary Parameters	Enable Conditions
None	

3. GENERAL DRIVING CYCLE

Always perform the diagnosis continuously.

4. DIAGNOSTIC METHOD

Judge as NG when the continuous time when the following conditions are established is more than 0.5 seconds. Judge as OK and clear the NG when the following conditions are not established.

Judgment Value

Malfunction Criteria	Threshold Value
Output voltage	≥ 4.716 V

Time Needed for Diagnosis: 0.5 seconds

Malfunction Indicator Light Illumination: Illuminates as soon as a malfunction occurs.

5. DTC CLEAR CONDITION

- When the OK idling cycle is completed 40 times in a row
- When "Clear Memory" is performed

6. MALFUNCTION INDICATOR LIGHT CLEAR CONDITION

- When the OK driving cycle is completed 3 times in a row
- When "Clear Memory" is performed

7. FAIL SAFE

Oil temperature sensor process: Engine oil temperature is fixed at 70°C (158°F).

8. ECM OPERATION AT DTC SETTING

Memorize the freeze frame data. (For test mode \$02)

Diagnostic Trouble Code (DTC) Detecting Criteria

GENERAL DESCRIPTION

AR:DTC P0222 THROTTLE/PEDAL POSITION SENSOR/SWITCH “B” CIRCUIT LOW

1. OUTLINE OF DIAGNOSIS

Detect the open or short circuit of throttle position sensor 2.
Judge as NG if it is out of specification.

2. COMPONENT DESCRIPTION

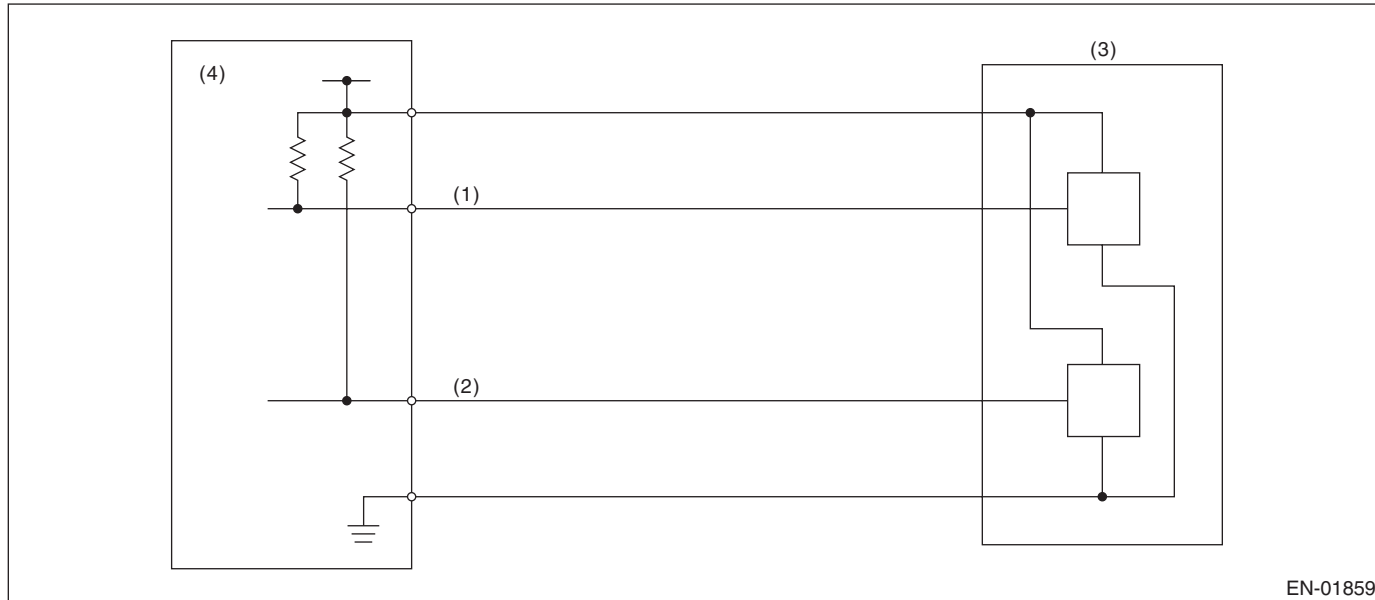

- (1) Throttle position sensor 1 signal (3) Throttle position sensor (4) Engine control module (ECM)
(2) Throttle position sensor 2 signal

3. ENABLE CONDITION

Secondary Parameters	Enable Conditions
Ignition switch	ON

4. GENERAL DRIVING CYCLE

Always perform the diagnosis continuously.

5. DIAGNOSTIC METHOD

Judge as OK and clear the NG when the malfunction criteria below are met.

Judgment Value

Malfunction Criteria	Threshold Value
Sensor 2 input voltage	≥ 0.749 V

Time Needed for Diagnosis: 24 milliseconds

Malfunction Indicator Light Illumination: Illuminates as soon as a malfunction occurs.

6. DTC CLEAR CONDITION

- When the OK idling cycle is completed 40 times in a row
- When “Clear Memory” is performed (Only with engine stopped)

7. MALFUNCTION INDICATOR LIGHT CLEAR CONDITION

- When the OK driving cycle is completed 3 times in a row
- When “Clear Memory” is performed (Only with engine stopped)

8. FAIL SAFE

Stop the continuity to the electronic throttle control motor. (Throttle opening is fixed to 6°.)

9. ECM OPERATION AT DTC SETTING

Memorize the freeze frame data. (For test mode \$02)

Diagnostic Trouble Code (DTC) Detecting Criteria

GENERAL DESCRIPTION

AS:DTC P0223 THROTTLE/PEDAL POSITION SENSOR/SWITCH "B" CIRCUIT HIGH

1. OUTLINE OF DIAGNOSIS

Detect the open or short circuit of throttle position sensor 2.
Judge as NG if it is out of specification.

2. COMPONENT DESCRIPTION

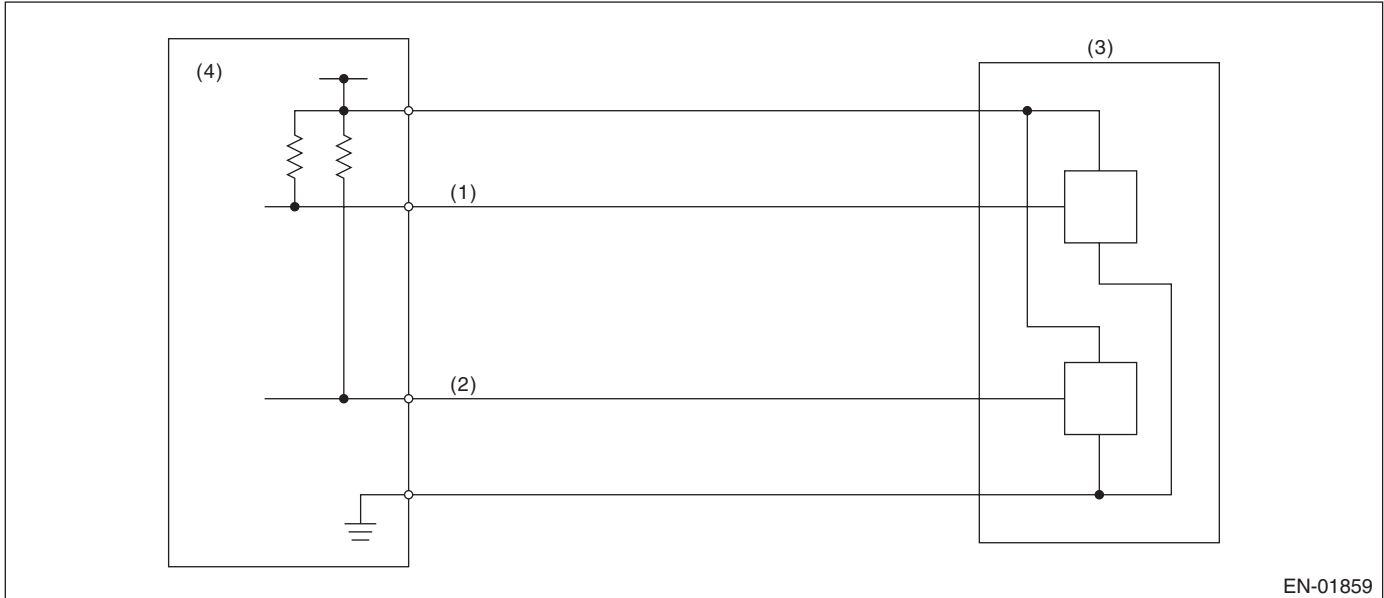

- (1) Throttle position sensor 1 signal (3) Throttle position sensor (4) Engine control module (ECM)
(2) Throttle position sensor 2 signal

3. ENABLE CONDITION

Secondary Parameters	Enable Conditions
Ignition switch	ON

4. GENERAL DRIVING CYCLE

Always perform the diagnosis continuously.

5. DIAGNOSTIC METHOD

Judge as OK and clear the NG when the malfunction criteria below are met.

Judgment Value

Malfunction Criteria	Threshold Value
Sensor 2 input voltage	≤ 4.747 V

Time Needed for Diagnosis: 24 milliseconds

Malfunction Indicator Light Illumination: Illuminates as soon as a malfunction occurs.

6. DTC CLEAR CONDITION

- When the OK idling cycle is completed 40 times in a row
- When "Clear Memory" is performed (Only with engine stopped)

7. MALFUNCTION INDICATOR LIGHT CLEAR CONDITION

- When the OK driving cycle is completed 3 times in a row
- When "Clear Memory" is performed (Only with engine stopped)

8. FAIL SAFE

Stop the continuity to the electronic throttle control motor. (Throttle opening is fixed to 6°.)

9. ECM OPERATION AT DTC SETTING

Memorize the freeze frame data. (For test mode \$02)

Diagnostic Trouble Code (DTC) Detecting Criteria

GENERAL DESCRIPTION

AT:DTC P0301 CYLINDER 1 MISFIRE DETECTED

1. OUTLINE OF DIAGNOSIS

Detect the presence of misfire occurrence. (Revolution fluctuation method)

Monitoring misfire which influences exhaust deterioration (1.5 times of FTP) and catalyst damage is made obligatory by the law. Misfire affecting these two has two patterns below.

- Intermittent misfire (The same cylinder misfires in random, or different cylinders misfire in random.): FTP 1.5 times misfire
- Every time misfire (The same cylinder misfires every time.): FTP 1.5 times misfire, Catalyst damage misfire

The following detecting methods are adopted for these detection.

1) Intermittent misfire: FTP 1.5 times misfire

- 180° Interval Difference Method (MT: 1,800 rpm or less; AT: None)
- 360° Interval Difference Method (whole range)
- 720° Interval Difference Method (3,000 rpm or more)

2) Every time misfire: FTP 1.5 times misfire, Catalyst damage misfire

- 360° Interval Difference Method

2. ENABLE CONDITION

Secondary Parameters	Enable Conditions
All secondary parameters enable conditions	1 second or more
Intake manifold pressure change during 0.5 engine revs.	< 13.3 kPa (100 mmHg, 3.94 inHg)
Throttle position change during 16 milliseconds	< 21°
Fuel shut-off function	Not in operation
Atmospheric pressure	≥ 75.0 kPa (563 mmHg, 22.2 inHg)
Fuel level	≥ 9.0 ℓ (2.38 US gal, 1.98 Imp gal)
AT torque control	Not in operation
Evaporative system leak check	Not in operation
Engine speed	460 — 6,400 rpm
Intake manifold pressure	> Value from Map 3
Battery voltage	≥ 8 V
Fuel parameter determination	Not extremely low volatility

Diagnostic Trouble Code (DTC) Detecting Criteria

GENERAL DESCRIPTION

Map 3

MT (Vehicle Speed < 64 km/h (40 MPH))

rpm	650	1000	1500	2000	2500	3000	3500	4000	4500	5000	5500	6000	6400
kPa (mmHg, inHg)	25.6 (192, 7.56)	23.1 (173, 6.82)	20.0 (150, 5.91)	20.0 (150, 5.91)	20.0 (150, 5.91)	21.6 (162, 6.38)	26.4 (198, 7.80)	28.0 (210, 8.27)	29.5 (221, 8.71)	32.4 (243, 9.57)	36.4 (273, 10.75)	39.9 (299, 11.78)	44.5 (324, 13.14)

MT (Vehicle Speed ≥ 64 km/h (40 MPH))

rpm	650	1000	1500	2000	2500	3000	3500	4000	4500	5000	5500	6000	6400
kPa (mmHg, inHg)	31.6 (237, 9.33)	31.6 (237, 9.33)	31.6 (237, 9.33)	31.1 (233, 9.19)	31.3 (235, 9.24)	33.1 (248, 9.78)	33.9 (254, 10.01)	28.8 (216, 8.51)	30.1 (226, 8.89)	33.3 (250, 9.84)	36.9 (277, 10.90)	40.1 (301, 11.84)	44.5 (324, 13.14)

AT

rpm	700	1000	1500	2000	2500	3000	3500	4000	4500	5000	5500	6000	6400
kPa (mmHg, inHg)	25.6 (192, 7.56)	24.4 (183, 7.21)	22.0 (165, 6.50)	22.4 (168, 6.62)	22.8 (171, 6.73)	23.9 (179, 7.06)	29.9 (224, 8.83)	31.3 (235, 9.24)	29.9 (244, 8.83)	35.6 (267, 10.51)	39.3 (295, 11.61)	43.3 (325, 12.79)	44.5 (334, 13.14)

3. GENERAL DRIVING CYCLE

- Detect misfires from idling to high rpm.
- Perform the diagnosis continuously.

4. DIAGNOSTIC METHOD

When a misfire occurs, the engine speed will decreased and the crankshaft position speed will change. Calculate the interval difference value (diagnostic value) from crankshaft position speed by the following formula, and judge whether a misfire is occurring or not comparing the calculated result with judgment value. Counting the number of misfires, if the misfire ratio is higher during 1000 rev. or 200 rev., Judge corresponding cylinders as NG.

Diagnostic value calculation (Calculate from angle speed)	→	Misfire detection every single ignition (Compare diagnostic value with judgment value)	→	NG judgment (Misfire occurrence judgment required by the law) (Compare number of misfire with judgment)
		<ul style="list-style-type: none"> • 180° Interval Difference Method • 360° Interval Difference Method • 720° Interval Difference Method 		<ul style="list-style-type: none"> • FTP 1.5 times misfire NG judgment • Catalyst damage misfire NG judgment

Diagnostic Trouble Code (DTC) Detecting Criteria

GENERAL DESCRIPTION

As shown in the following figure, pick a cylinder as the standard and name it ω_0 . And the former crankshaft position speed is named ω_1 , the second former crankshaft position speed is named ω_2 , the third is named ω_3 , etc.

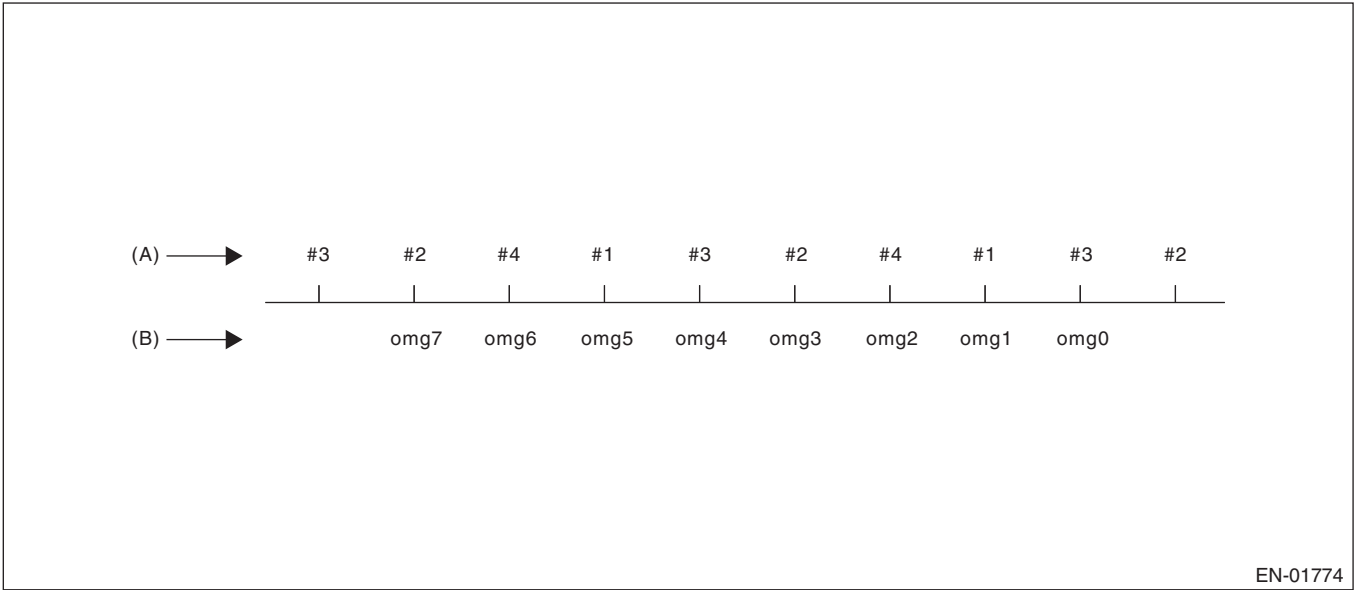

EN-01774

(A) Ignition order

(B) Crankshaft position speed

180° Interval Difference Method

Diagnostic value $\text{domg180} = (\omega_1 - \omega_0) - (\omega_5 - \omega_1)/4$

Judge as a misfire in the following cases.

- $\text{domg180} > \text{judgment value of positive side}$
 - $\text{domg180} \leq \text{judgment value of negative side}$
- (Judgment value before 180°CA)

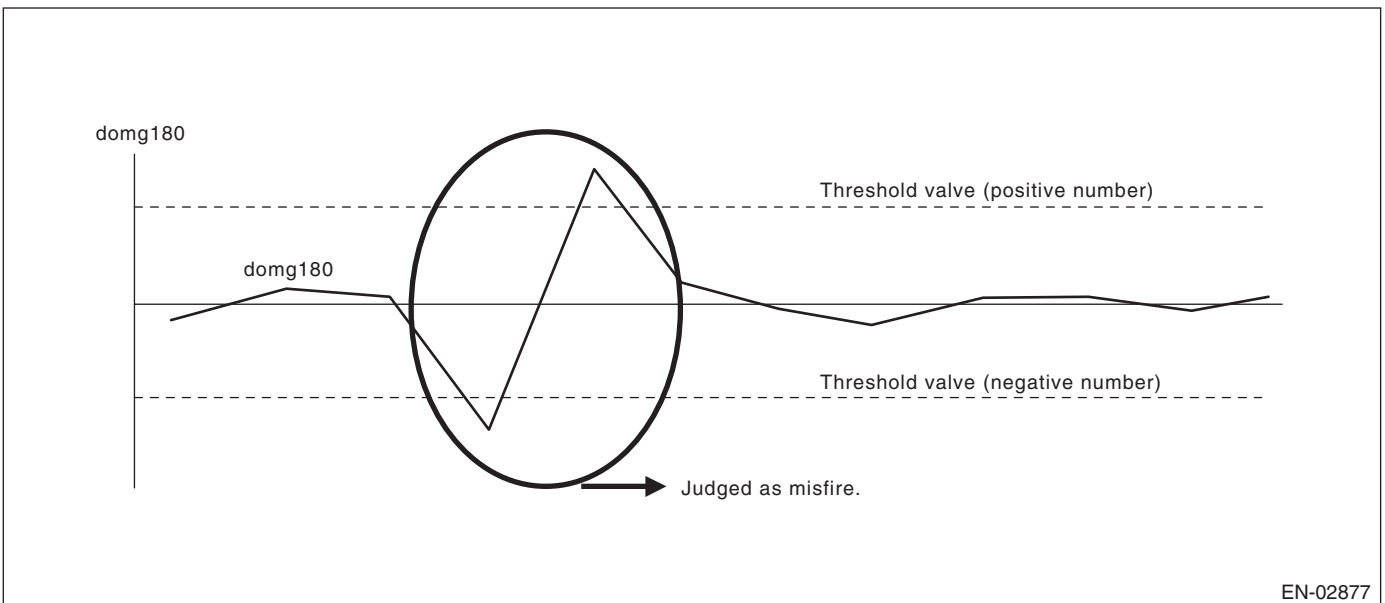

EN-02877

Diagnostic Trouble Code (DTC) Detecting Criteria

GENERAL DESCRIPTION

360° Interval Difference Method

Diagnostic value	$\text{domg } 360 = (\text{omg } 1 - \text{omg } 0) - (\text{omg } 3 - \text{omg } 2)$
Misfire judgment	$\text{domg } 360 > \text{Judgment value} \rightarrow \text{Judge as misfire}$

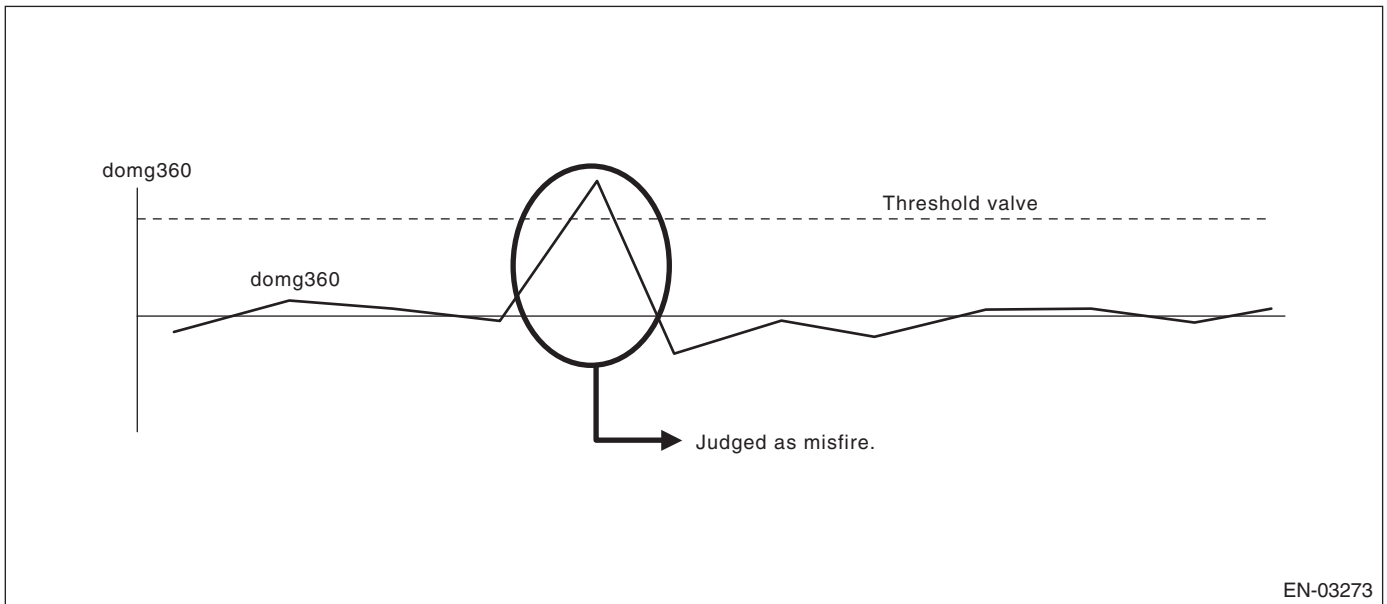

EN-03273

720° Interval Difference Method

Diagnostic value	$\text{domg } 720 = (\text{omg } 1 - \text{omg } 0) - (\text{omg } 5 - \text{omg } 4)$
Misfire judgment	$\text{domg } 720 > \text{Judgment value} \rightarrow \text{Judge as misfire}$

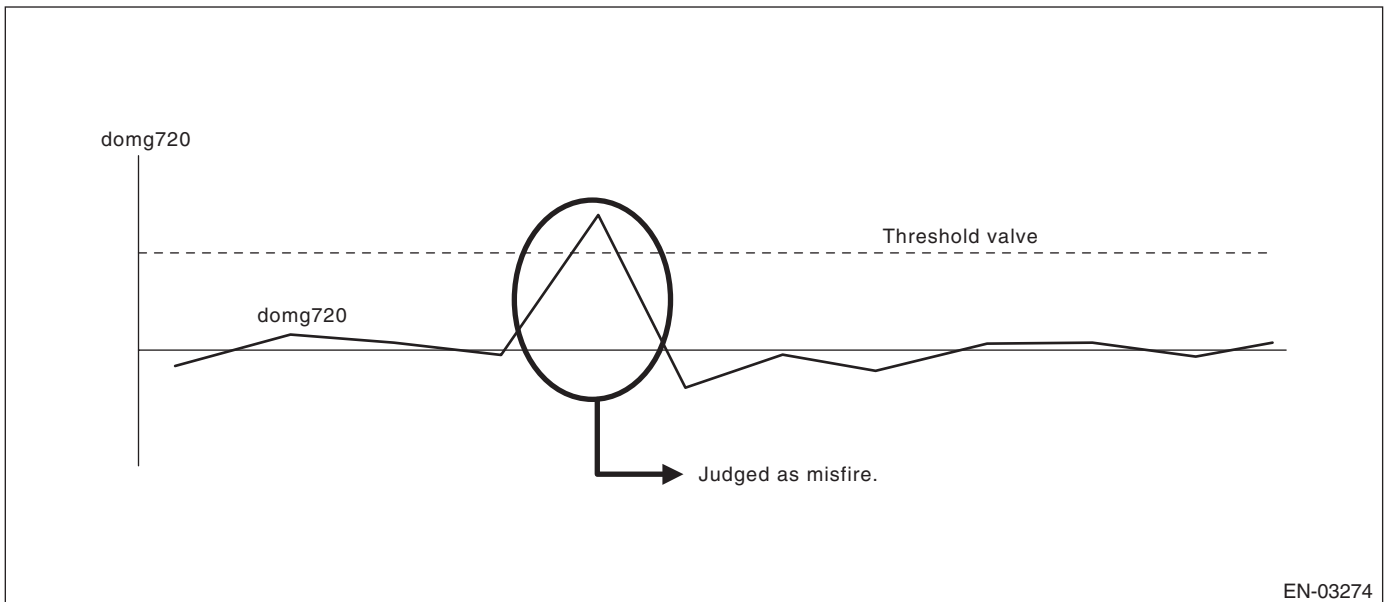

EN-03274

Diagnostic Trouble Code (DTC) Detecting Criteria

GENERAL DESCRIPTION

FTP 1.5 times misfire (Misfire occurrence level which influences exhaust gas)

Judgment Value (Judge that malfunction occurs when the misfire ratio is high in 1000 engine revs.)

Malfunction Criteria	Threshold Value
FTP emission diagnostic value	> 1.0 % in 1000 revs

Time Needed for Diagnosis: 1000 engine revs.

Malfunction Indicator Light Illumination: Illuminates when malfunction occurs in 2 continuous driving cycles.

Catalyst damage misfire (Misfire occurrence level damaging catalyst)

Judgment Value (Judge that malfunction occurs when the misfire ratio is high in 200 engine revs. (400 ignitions))

Malfunction Criteria	Threshold Value
Catalyst damage misfire diagnostic value	See Map 1

Map 1 Threshold value of malfunction criteria for misfire damaging catalyst

percentage		Intake air (g (oz)/rev)									
		0.16 (0.0006)	0.28 (0.010)	0.4 (0.014)	0.52 (0.018)	0.64 (0.023)	0.76 (0.027)	0.92 (0.032)	1.1 (0.039)	1.2 (0.042)	1.3 (0.046)
Engine speed (rpm)	700	25	25	25	25	22.5	20	16	12	12	12
	1000	25	25	25	25	22.5	20	15.75	11	11	11
	1500	25	25	22.5	20	18.25	16.75	13.5	10	10	10
	2000	20	20	20	20	17	14.25	12.75	11	11	11
	2500	20	20	18.25	16.75	15.5	14.25	12.75	11	11	11
	3000	16.75	16.75	15.5	14.25	12.75	11	11	11	11	11
	3500	16.75	16.75	14	11	10	9	8.5	7.75	7.75	7.75
	4000	14.25	14.25	11	7.75	6	5	5	5	5	5
	4500	11	11	8.25	7.75	5	5	5	5	5	5
	5000	11	11	9.5	7.75	5	5	5	5	5	5
	5500	9	9	7.75	6.75	5	5	5	5	5	5
6000	9	5	5	5	5	5	5	5	5	5	
6400	9	5	5	5	5	5	5	5	5	5	

These figures indicate the misfire rate (%) in 400 ignitions; for example, 22.5 (%) means 400 (ignition) × 22.5 (%) = 90 (ignition) misfires. This value or more is judged as a misfire.

Time Needed for Diagnosis: 200 engine revs.

Malfunction Indicator Light Illumination: Illuminates as soon as a malfunction occurs.

5. DTC CLEAR CONDITION

- When the OK idling cycle is completed 40 times in a row
- When "Clear Memory" is performed

6. MALFUNCTION INDICATOR LIGHT CLEAR CONDITION

- When the OK driving cycle is completed 3 times in a row
- When "Clear Memory" is performed

7. FAIL SAFE

None

8. ECM OPERATION AT DTC SETTING

Memorize the freeze frame data. (For test mode \$02)

Diagnostic Trouble Code (DTC) Detecting Criteria

GENERAL DESCRIPTION

AU:DTC P0302 CYLINDER 2 MISFIRE DETECTED

NOTE:

For the diagnostic procedure, refer to DTC P0301. <Ref. to GD(H4SO)-94, DTC P0301 CYLINDER 1 MISFIRE DETECTED, Diagnostic Trouble Code (DTC) Detecting Criteria.>

AV:DTC P0303 CYLINDER 3 MISFIRE DETECTED

NOTE:

For the diagnostic procedure, refer to DTC P0301. <Ref. to GD(H4SO)-94, DTC P0301 CYLINDER 1 MISFIRE DETECTED, Diagnostic Trouble Code (DTC) Detecting Criteria.>

AW:DTC P0304 CYLINDER 4 MISFIRE DETECTED

NOTE:

For the diagnostic procedure, refer to DTC P0301. <Ref. to GD(H4SO)-94, DTC P0301 CYLINDER 1 MISFIRE DETECTED, Diagnostic Trouble Code (DTC) Detecting Criteria.>

Diagnostic Trouble Code (DTC) Detecting Criteria

GENERAL DESCRIPTION

AX:DTC P0327 KNOCK SENSOR 1 CIRCUIT LOW (BANK 1 OR SINGLE SENSOR)

1. OUTLINE OF DIAGNOSIS

Detect the open or short circuit of knock sensor.

Judge as NG if it is out of specification.

2. COMPONENT DESCRIPTION

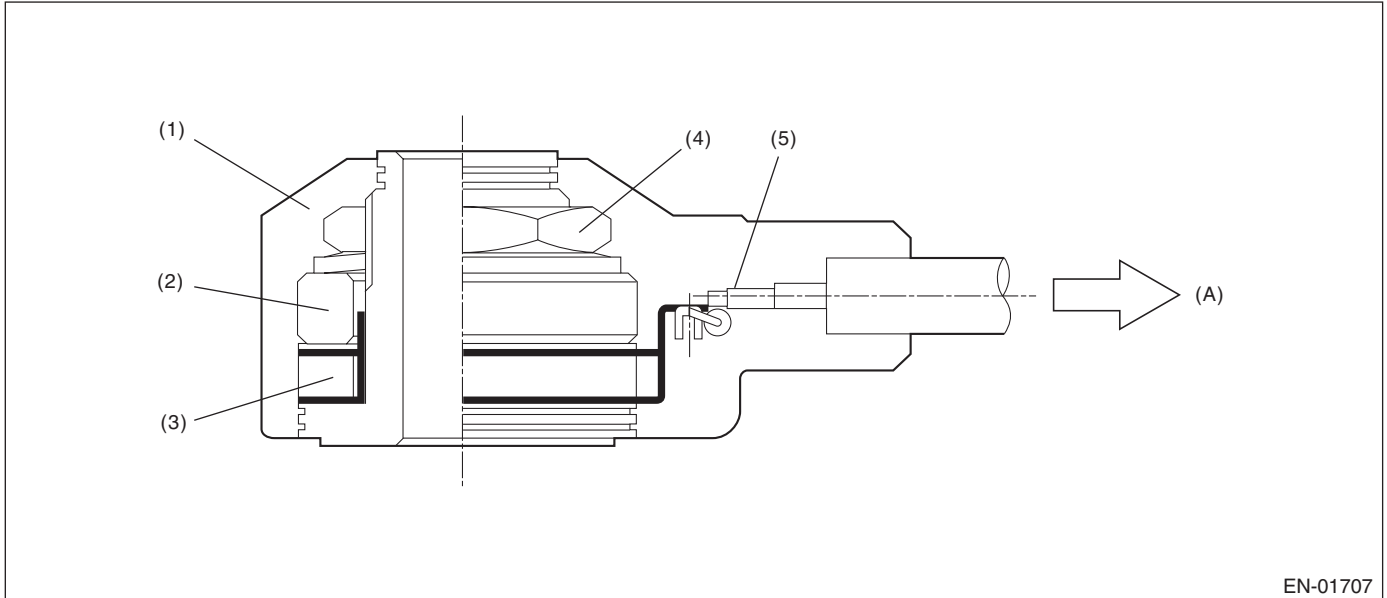

(1) Case

(2) Weight

(3) Piezoelectric element

(4) Nut

(5) Resistance

(A) To knock sensor harness

3. ENABLE CONDITION

Secondary Parameters	Enable Conditions
None	

4. GENERAL DRIVING CYCLE

Always perform the diagnosis continuously.

Diagnostic Trouble Code (DTC) Detecting Criteria

GENERAL DESCRIPTION

5. DIAGNOSTIC METHOD

Abnormality Judgment

Judge as NG when the continuous time of meeting the malfunction criteria below becomes 1 second or more.

Judgment Value

Malfunction Criteria	Threshold Value
Output voltage	< 0.238 V
Ignition switch	ON

Time Needed for Diagnosis: 1 second

Malfunction Indicator Light Illumination: Illuminates as soon as a malfunction occurs.

Normality Judgment

Judge as OK and clear the NG when the malfunction criteria below are met.

Judgment Value

Malfunction Criteria	Threshold Value
Output voltage	≥ 0.25 V
Ignition switch	ON

6. DTC CLEAR CONDITION

- When the OK idling cycle is completed 40 times in a row
- When "Clear Memory" is performed

7. MALFUNCTION INDICATOR LIGHT CLEAR CONDITION

- When the OK driving cycle is completed 3 times in a row
- When "Clear Memory" is performed

8. FAIL SAFE

None

9. ECM OPERATION AT DTC SETTING

Memorize the freeze frame data. (For test mode \$02)

Diagnostic Trouble Code (DTC) Detecting Criteria

GENERAL DESCRIPTION

AY:DTC P0328 KNOCK SENSOR 1 CIRCUIT HIGH (BANK 1 OR SINGLE SENSOR)

1. OUTLINE OF DIAGNOSIS

Detect the open or short circuit of knock sensor.
Judge as NG if it is out of specification.

2. COMPONENT DESCRIPTION

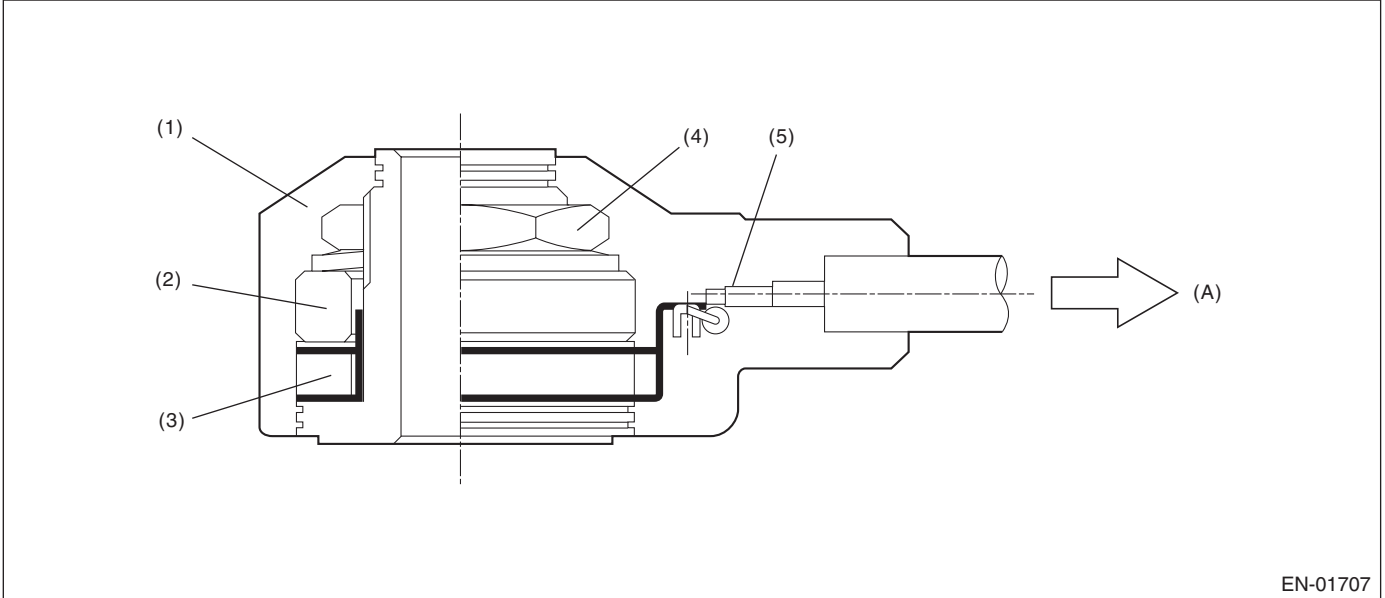

- (1) Case
- (2) Weight
- (3) Piezoelectric element

- (4) Nut
- (5) Resistance

- (A) To knock sensor harness

3. ENABLE CONDITION

Secondary Parameters	Enable Conditions
None	

4. GENERAL DRIVING CYCLE

Always perform the diagnosis continuously.

Diagnostic Trouble Code (DTC) Detecting Criteria

GENERAL DESCRIPTION

5. DIAGNOSTIC METHOD

Abnormality Judgment

Judge as NG when the continuous time of meeting the malfunction criteria below becomes 1 second or more.

Judgment Value

Malfunction Criteria	Threshold Value
Output voltage	≥ 4.714 V
Ignition switch	ON

Time Needed for Diagnosis: 1 second

Malfunction Indicator Light Illumination: Illuminates as soon as a malfunction occurs.

Normality Judgment

Judge as OK and clear the NG when the malfunction criteria below are met.

Judgment Value

Malfunction Criteria	Threshold Value
Output voltage	< 4.7 V
Ignition switch	ON

6. DTC CLEAR CONDITION

- When the OK idling cycle is completed 40 times in a row
- When "Clear Memory" is performed

7. MALFUNCTION INDICATOR LIGHT CLEAR CONDITION

- When the OK driving cycle is completed 3 times in a row
- When "Clear Memory" is performed

8. FAIL SAFE

None

9. ECM OPERATION AT DTC SETTING

Memorize the freeze frame data. (For test mode \$02)

Diagnostic Trouble Code (DTC) Detecting Criteria

GENERAL DESCRIPTION

AZ:DTC P0335 CRANKSHAFT POSITION SENSOR "A" CIRCUIT

1. OUTLINE OF DIAGNOSIS

Detect the open or short circuit of the crankshaft position sensor.

Judge as NG when the crank signal is not input even though the starter was turned on.

2. COMPONENT DESCRIPTION

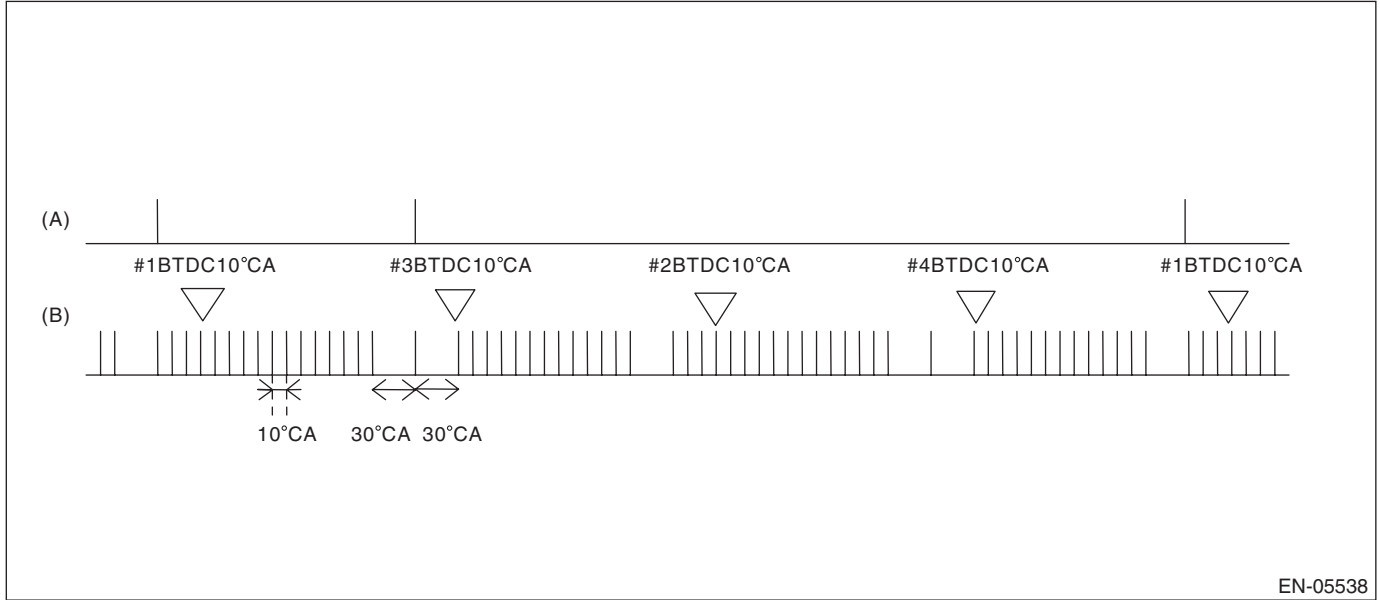

(A) Camshaft signal

(B) Crankshaft signal

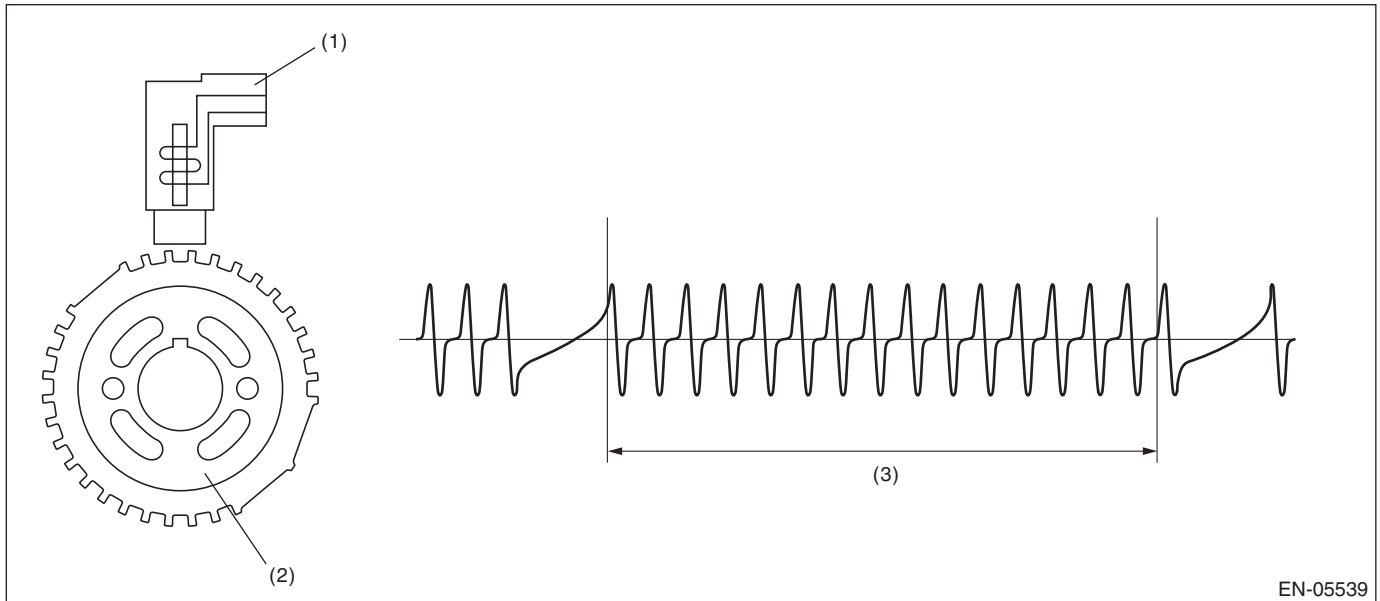

(1) Crankshaft position sensor

(2) Crank sprocket

(3) Crankshaft half-turn

3. ENABLE CONDITION

Secondary Parameters	Enable Conditions
None	

4. GENERAL DRIVING CYCLE

Always perform the diagnosis continuously.

Diagnostic Trouble Code (DTC) Detecting Criteria

GENERAL DESCRIPTION

5. DIAGNOSTIC METHOD

Abnormality Judgment

Judge as NG when the continuous time of meeting the malfunction criteria below becomes more than 3 seconds.

Judgment Value

Malfunction Criteria	Threshold Value
Starter switch	ON
Crankshaft position sensor signal	Not detected
Battery voltage	$\geq 8\text{ V}$

Time Needed for Diagnosis: 3 seconds

Malfunction Indicator Light Illumination: Illuminates as soon as a malfunction occurs.

Normality Judgment

Judge as OK when the malfunction criteria below are met.

Judgment Value

Malfunction Criteria	Threshold Value
Crankshaft position sensor signal	Input exists
Battery voltage	$\geq 8\text{ V}$

6. DTC CLEAR CONDITION

- When the OK idling cycle is completed 40 times in a row
- When "Clear Memory" is performed

7. MALFUNCTION INDICATOR LIGHT CLEAR CONDITION

- When the OK driving cycle is completed 3 times in a row
- When "Clear Memory" is performed

8. FAIL SAFE

None

9. ECM OPERATION AT DTC SETTING

Memorize the freeze frame data. (For test mode \$02)

Diagnostic Trouble Code (DTC) Detecting Criteria

GENERAL DESCRIPTION

BA:DTC P0336 CRANKSHAFT POSITION SENSOR "A" CIRCUIT RANGE/ PERFORMANCE

1. OUTLINE OF DIAGNOSIS

Detect for faults in crankshaft position sensor output properties.

Judge as NG when there is a problem in the number of crankshaft signals for every revolution.

2. COMPONENT DESCRIPTION

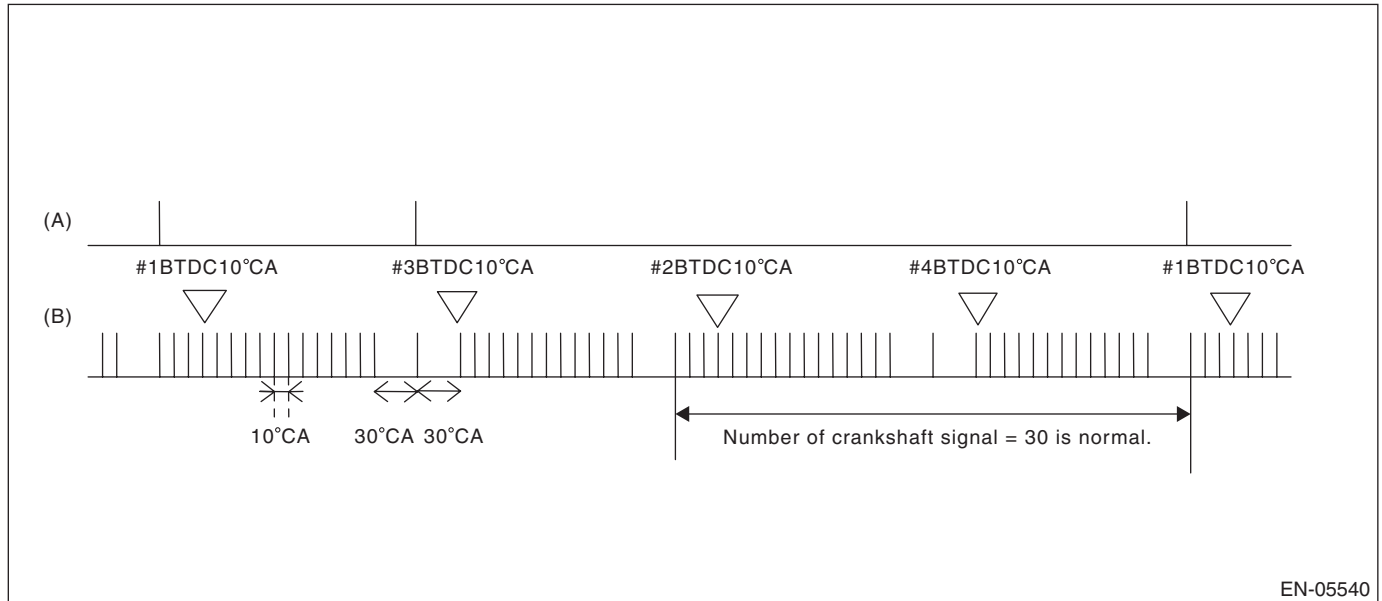

(A) Camshaft signal

(B) Crankshaft signal

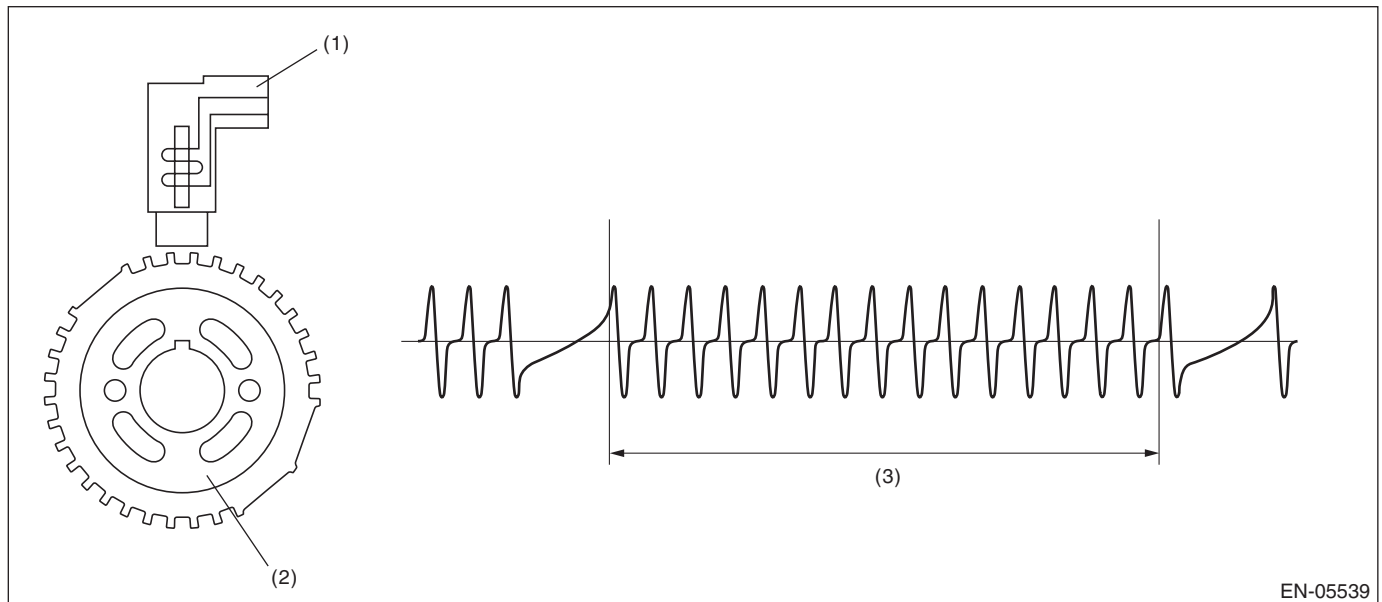

(1) Crankshaft position sensor

(2) Crank sprocket

(3) Crankshaft half-turn

3. ENABLE CONDITION

Secondary Parameters	Enable Conditions
Battery voltage	$\geq 8 \text{ V}$
Engine speed	$< 4000 \text{ rpm}$

Diagnostic Trouble Code (DTC) Detecting Criteria

GENERAL DESCRIPTION

4. GENERAL DRIVING CYCLE

Perform the diagnosis continuously under 4000 rpm engine speed.

5. DIAGNOSTIC METHOD

Abnormality Judgment

Judge as NG when all the malfunction criteria below are completed more than 10 times in a row.

Judgment Value

Malfunction Criteria	Threshold Value
Cylinder number identification	Completed
Number of crankshaft position sensor signal during 1 rev.	Not = 30

Time Needed for Diagnosis: 10 engine revs.

Malfunction Indicator Light Illumination: Illuminates when malfunction occurs in 2 continuous driving cycles.

Normality Judgment

Judge as OK and clear the NG when all the malfunction criteria below are met.

Judgment Value

Malfunction Criteria	Threshold Value
Cylinder number distinction	Completed
Number of crankshaft position sensor signal during 1 rev.	= 30

6. DTC CLEAR CONDITION

- When the OK idling cycle is completed 40 times in a row
- When "Clear Memory" is performed

7. MALFUNCTION INDICATOR LIGHT CLEAR CONDITION

- When the OK driving cycle is completed 3 times in a row
- When "Clear Memory" is performed

8. FAIL SAFE

None

9. ECM OPERATION AT DTC SETTING

Memorize the freeze frame data. (For test mode \$02)

Diagnostic Trouble Code (DTC) Detecting Criteria

GENERAL DESCRIPTION

BB:DTC P0340 CAMSHAFT POSITION SENSOR “A” CIRCUIT (BANK 1 OR SINGLE SENSOR)

1. OUTLINE OF DIAGNOSIS

Detect the open or short circuit of the camshaft position sensor.
Judge as NG when the number of camshaft signals remains abnormal.

2. COMPONENT DESCRIPTION

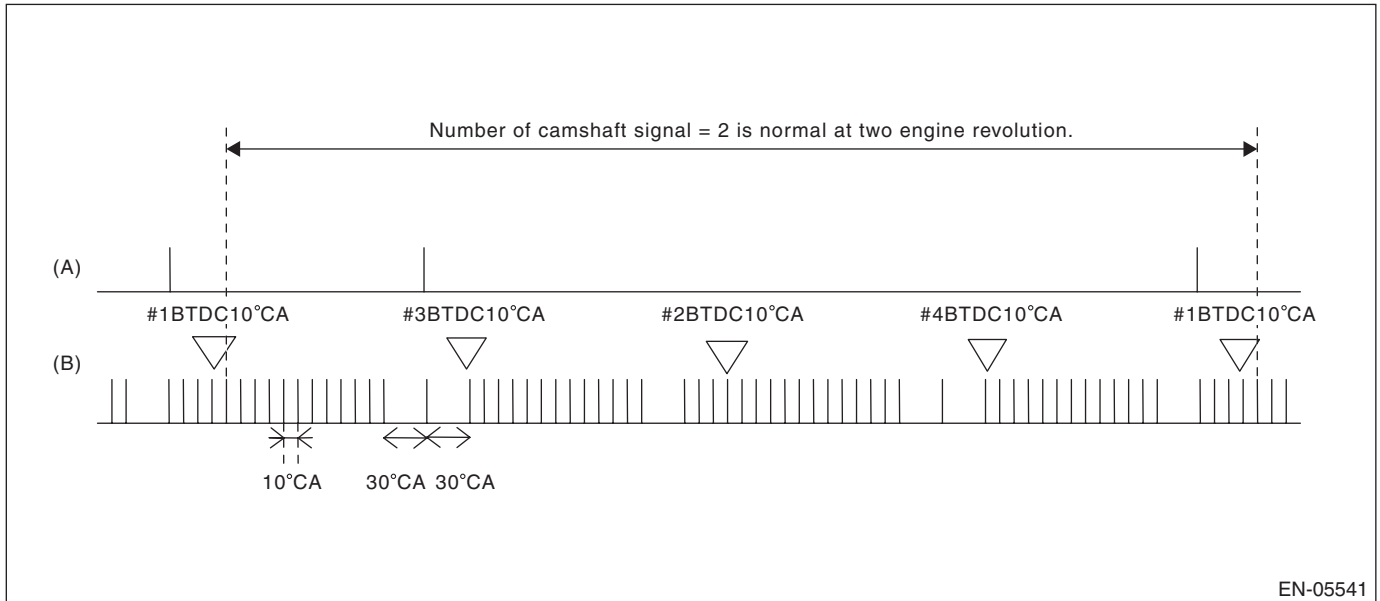

(A) Camshaft signal

(B) Crankshaft signal

3. ENABLE CONDITION

Secondary Parameters	Enable Conditions
None	

4. GENERAL DRIVING CYCLE

Always perform the diagnosis continuously.

Diagnostic Trouble Code (DTC) Detecting Criteria

GENERAL DESCRIPTION

5. DIAGNOSTIC METHOD

Abnormality Judgment

Judge as NG when the following malfunction criteria continues for 8 engine revolutions or more.

Judgment Value

Malfunction Criteria	Threshold Value
Voltage	$\geq 8 \text{ V}$
Number of camshaft sensor signals during 2 rev.	Not = 2

Time Needed for Diagnosis: 8 rev.

Malfunction Indicator Light Illumination: Illuminates as soon as a malfunction occurs.

Normality Judgment

Judge as OK and clear the NG when the following criteria are established.

Judgment Value

Malfunction Criteria	Threshold Value
Voltage	$\geq 8 \text{ V}$
Number of camshaft sensor signal during 2 rev.	2

6. DTC CLEAR CONDITION

- When the OK idling cycle is completed 40 times in a row
- When "Clear Memory" is performed

7. MALFUNCTION INDICATOR LIGHT CLEAR CONDITION

- When the OK driving cycle is completed 3 times in a row
- When "Clear Memory" is performed

8. FAIL SAFE

None

9. ECM OPERATION AT DTC SETTING

Memorize the freeze frame data. (For test mode \$02)

Diagnostic Trouble Code (DTC) Detecting Criteria

GENERAL DESCRIPTION

BC:DTC P0341 CAMSHAFT POSITION SENSOR "A" CIRCUIT RANGE/ PERFORMANCE (BANK 1 OR SINGLE SENSOR)

1. OUTLINE OF DIAGNOSIS

Detect the malfunction of camshaft position sensor output property.

Judge NG when the camshaft position signal input timing is shifted from the crankshaft position sensor signal because of timing belt tooth chip etc.

2. COMPONENT DESCRIPTION

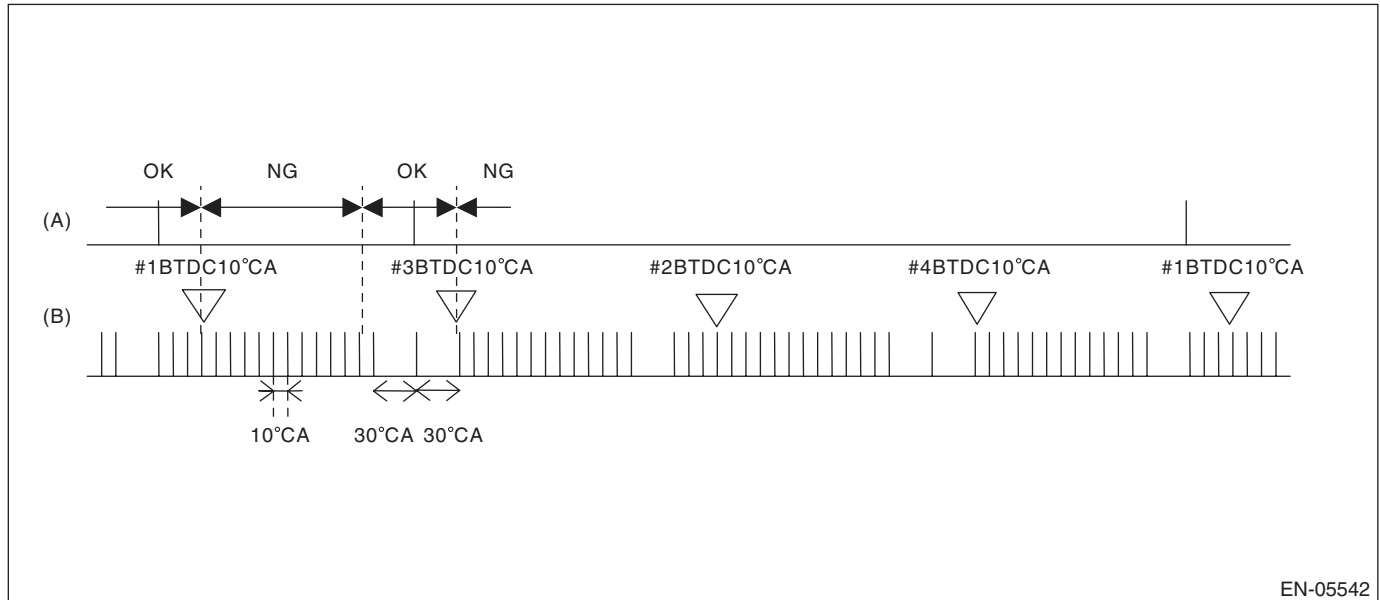

(A) Camshaft signal

(B) Crankshaft signal

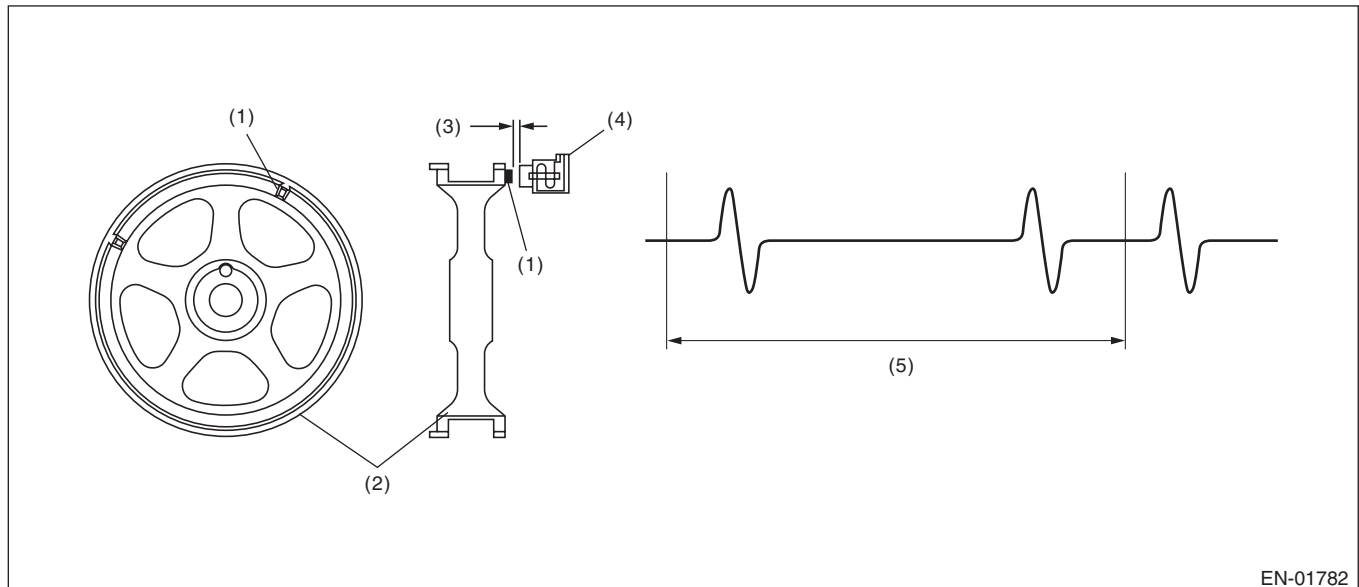

(1) Boss
(2) Cam sprocket

(3) Air gap
(4) Camshaft position sensor

(5) Camshaft one revolution (Engine two revolutions)

Diagnostic Trouble Code (DTC) Detecting Criteria

GENERAL DESCRIPTION

3. ENABLE CONDITION

Secondary Parameters	Enable Conditions
Cylinder number identification	Completed
Battery voltage	≥ 8 V
Engine speed	550 — 1,000 rpm
Engine operation	Idling
Misfire	Not detected

4. GENERAL DRIVING CYCLE

Always perform the diagnosis continuously at idle speed.

5. DIAGNOSTIC METHOD

Judge NG when the engine speed continues 4 revolutions for the malfunction criteria below. Judge as OK and clear the NG when the malfunction criteria below are not met.

Judgment Value

Malfunction Criteria	Threshold Value
Position of camshaft position sensor signal	Not between BTDC 10°CA and BTDC 80°CA

Time Needed for Diagnosis: 4 revs.

Malfunction Indicator Light Illumination: Illuminates when malfunction occurs in 2 continuous driving cycles.

6. DTC CLEAR CONDITION

- When the OK idling cycle is completed 40 times in a row
- When “Clear Memory” is performed

7. MALFUNCTION INDICATOR LIGHT CLEAR CONDITION

- When the OK driving cycle is completed 3 times in a row
- When “Clear Memory” is performed

8. FAIL SAFE

None

9. ECM OPERATION AT DTC SETTING

Memorize the freeze frame data. (For test mode \$02)

Diagnostic Trouble Code (DTC) Detecting Criteria

GENERAL DESCRIPTION

BD:DTC P0400 EXHAUST GAS RECIRCULATION FLOW

1. OUTLINE OF DIAGNOSIS

Detect EGR system malfunction.

Intake manifold pressure (negative pressure) is constant because the throttle valve is fully closed during deceleration fuel cut. At this time, when the EGR valve is opened/closed, the intake manifold pressure will change. EGR system OK/NG is judged by the range of this change.

2. COMPONENT DESCRIPTION

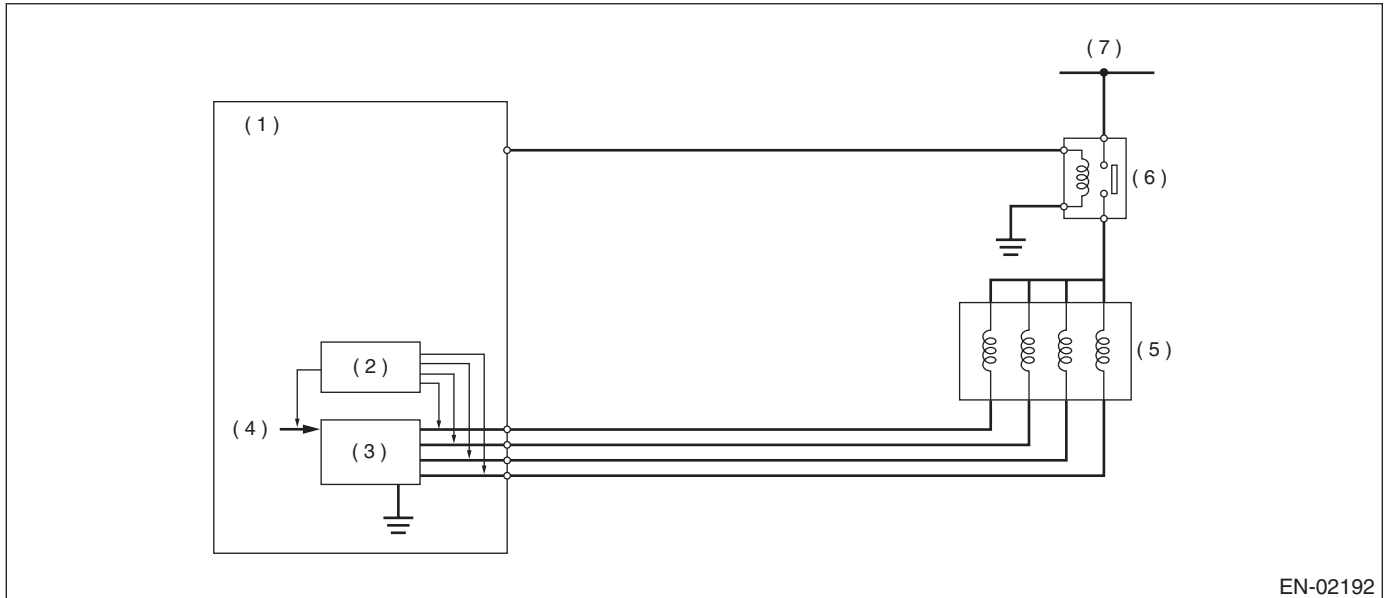

EN-02192

- | | | |
|-----------------------|---------------|--------------------------|
| (1) ECM | (4) CPU | (6) Main relay |
| (2) Detecting circuit | (5) EGR valve | (7) Battery power supply |
| (3) Switching circuit | | |

3. ENABLE CONDITION

Secondary Parameters	Enable Conditions
After engine starting	40 seconds or more
Engine coolant temperature	$\geq 75^{\circ}\text{C}$ (167°F)
Engine speed	1200 — 2,950 rpm
Intake manifold pressure (absolute pressure)	< 40.0 kPa (300 mmHg, 11.81 inHg)
Ambient air temperature	$\geq 5^{\circ}\text{C}$ (41°F)
Throttle position	$< 0.25^{\circ}$
Battery voltage	> 10.9 V
Atmospheric pressure	≥ 75.0 kPa (563 mmHg, 22.17 inHg)
Vehicle speed	≥ 53 km/h (33 MPH)
Fuel shut-off function	In operation
Neutral switch	Over 1 second after changing from OFF and ON to OFF.
Load (A/C, power steering, lighting, rear defogger, heater fan and radiator fan)	No change for over 5 seconds.

4. GENERAL DRIVING CYCLE

During deceleration fuel cut from more than 53 km/h (approx. 33 MPH), perform diagnosis once. Be careful of vehicle speed and engine speed. (Diagnosis will not be completed if the vehicle speed and engine speed conditions become out of specification due to deceleration.)

Diagnostic Trouble Code (DTC) Detecting Criteria

GENERAL DESCRIPTION

5. DIAGNOSTIC METHOD

Measure the pressure values as follows when the enable conditions are established, and perform diagnosis by calculating those results.

1. Label the intake manifold pressure value as PMOF1, which is observed when enable conditions are established, and set the EGR target step to 50 steps (nearly full open).
2. Label the intake manifold pressure value as PMON, which is observed after one second has passed since EGR target step was set to 50 steps (when the enable conditions were established), and set the EGR target step to 0.
3. Label the intake manifold pressure value as PMOF2, which is observed after one second has passed since EGR target step was set to 0 (after two seconds have passed since the enable conditions were established).

Abnormality Judgment

Judge as NG when the following conditions are established, and judge as OK when not.

$PMON - (PMOF1 + PMOF2) / 2 < 2.48 \text{ kPa (18.63 mmHg, 0.733 inHg)}$

Time Needed for Diagnosis: 1 time

Diagnostic Trouble Code (DTC) Detecting Criteria

GENERAL DESCRIPTION

Malfunction Indicator Light Illumination: Illuminates when malfunction occurs in 2 continuous driving cycles.

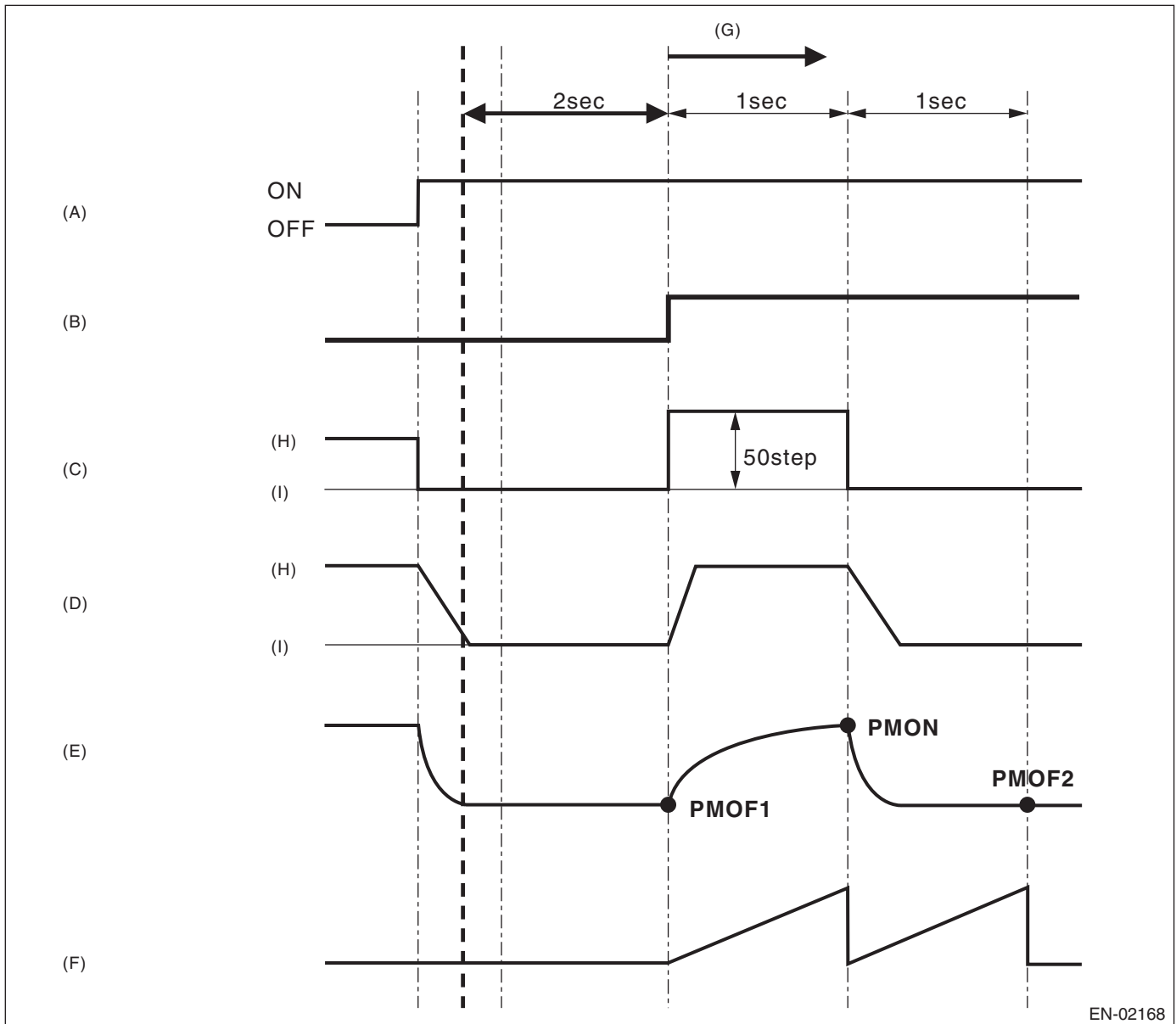

EN-02168

- | | | |
|---------------------------------|--|---------------------|
| (A) Deceleration fuel cut | (E) Intake manifold pressure (During normal condition) | (G) Start diagnosis |
| (B) Diagnosis enable conditions | (F) Diagnostic mode timer | (H) Open |
| (C) EGR target step | | (I) Closed |
| (D) EGR actual step | | |

6. DTC CLEAR CONDITION

- When the OK idling cycle is completed 40 times in a row
- When "Clear Memory" is performed

7. MALFUNCTION INDICATOR LIGHT CLEAR CONDITION

- When the OK driving cycle is completed 3 times in a row
- When "Clear Memory" is performed

Diagnostic Trouble Code (DTC) Detecting Criteria

GENERAL DESCRIPTION

8. FAIL SAFE

A/F main learning = Not allowed.

Knock learning = Not allowed.

EGR control: Not allowed to operate.

9. ECM OPERATION AT DTC SETTING

- Memorize the freeze frame data. (For test mode \$02)
- Memorize the diagnostic value and trouble standard value. (For test mode \$06)

Diagnostic Trouble Code (DTC) Detecting Criteria

GENERAL DESCRIPTION

BE:DTC P0420 CATALYST SYSTEM EFFICIENCY BELOW THRESHOLD (BANK 1)

1. OUTLINE OF DIAGNOSIS

Detect the deterioration of the catalytic function.

Though the front oxygen sensor output would change slowly with a new catalyst, the sensor output with a deteriorated catalyst becomes high and the inversion time is shortened.

For this reason, the catalyst diagnosis is carried out by monitoring the front oxygen sensor output and comparing it with the front oxygen (A/F) sensor output.

2. COMPONENT DESCRIPTION

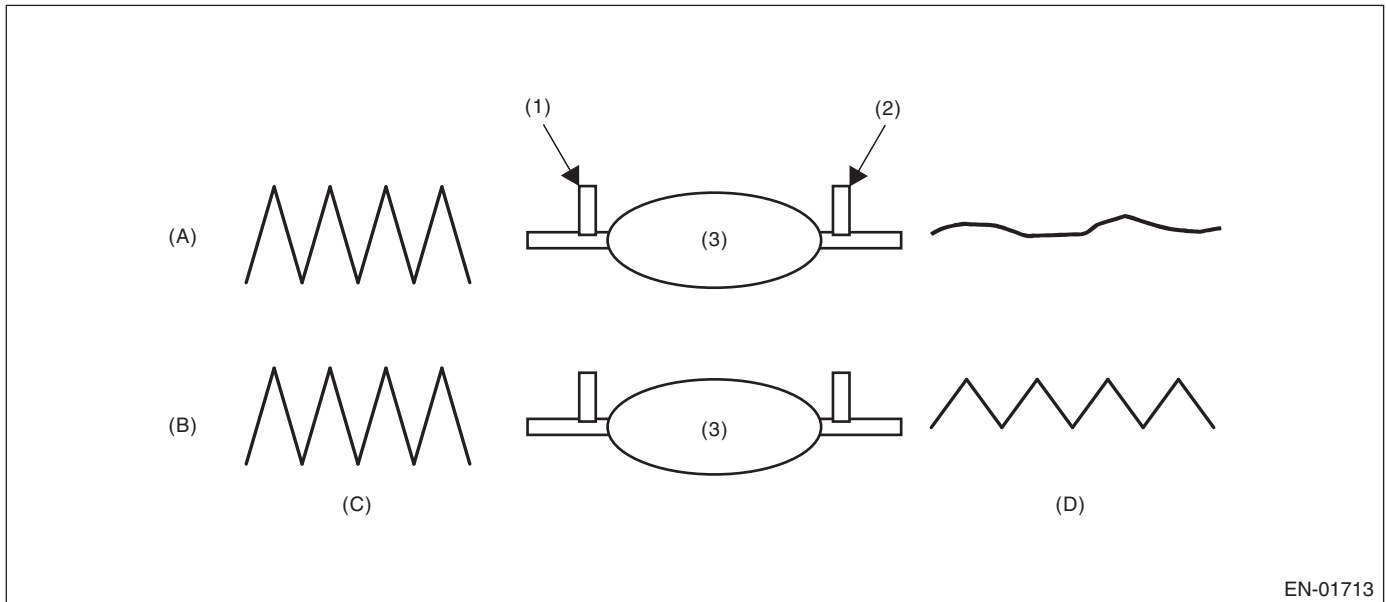

- (1) Front oxygen (A/F) sensor
- (2) Front oxygen sensor
- (3) Catalytic converter

- (A) Normal
- (B) Deterioration

- (C) Output waveform from the front oxygen (A/F) sensor
- (D) Output waveform from the front oxygen sensor

Diagnostic Trouble Code (DTC) Detecting Criteria

GENERAL DESCRIPTION

3. ENABLE CONDITION

Secondary Parameters	Enable Conditions
Battery voltage	> 10.9 V
Atmospheric pressure	> 75.1 kPa (563 mmHg, 22.2 inHg)
Engine coolant temperature	≥ 70°C (158°F)
Catalyst warm-up counter (Map 2) (U5 model)	≥ 9000
Misfire detection during 200 revs.	< 5 times
Learning value of evaporation gas density	≤ 0.20
Sub feedback	In operation
Evaporative system diagnosis	Not in operation
Time of difference (< 0.10) between actual and target lambda	1000 milliseconds or more
Vehicle speed	> 70 km/h (43.5 MPH)
Amount of intake air	10 — 40 g (0.35 — 1.41 oz)/s
Engine load change every 0.5 engine revs.	< 0.02 g (0.001 oz)/rev
Rear oxygen output change from lower than 660 mV to higher than 660 mV	Experienced after fuel cut
After engine starting	≥ 205 sec.
Purge execution calculated time	5 seconds or more
Time from recovering from the fuel cut (U5 model)	≥ Value from Map 23
Estimated temperature inside catalyst layer (other than U5 model)	≥ 650°C (1202°F)

Map 2

Add the following value every 512 milliseconds.

Intake amount of air (g(oz)/s)	0 (0)	3.2 (0.113)	6.4 (0.226)	9.6 (0.339)	12.8 (0.451)	16 (0.564)	19.2 (0.677)	22.4 (0.790)	25.6 (0.903)	28.8 (1.016)	32 (1.129)	35.2 (1.242)
Total value for warm-up counter	-5	-5	15	31	46	62	77	92	108	123	127	127

Map 23

Time from recovering from the fuel cut (ms)	5000	30000	60000	180000
Value (ms)	0	60000	180000	300000

4. GENERAL DRIVING CYCLE

Perform the diagnosis only once at a constant speed of 70 km/h (43 MPH).

Diagnostic Trouble Code (DTC) Detecting Criteria

GENERAL DESCRIPTION

5. DIAGNOSTIC METHOD

After establishing the execution conditions, calculate the front oxygen (A/F) sensor lambda deviation cumulative value per 128 milliseconds ($\sum |(\text{sglmd}_n - \text{sglmd}_{n-1})|$) and rear oxygen sensor output voltage deviation cumulative value ($\sum |(\text{ro2sad}_n - \text{ro2sad}_{n-1})|$), and when the front oxygen (A/F) sensor lambda deviation cumulative value ($\sum |(\text{sglmd}_n - \text{sglmd}_{n-1})|$) becomes higher than the predetermined value, calculate the diagnostic value.

Judge as NG when the malfunction criteria below are met. Judge as OK if the criteria below are not met.

Judgment Value

Malfunction Criteria	Threshold Value
$\sum (\text{ro2sad}_n - \text{ro2sad}_{n-1}) / \sum (\text{sglmd}_n - \text{sglmd}_{n-1}) $	> 15.4 (U5 model), > 18.5 (other than U5 model)

Time Needed for Diagnosis: 30 to 55 seconds

Malfunction Indicator Light Illumination: Illuminates when malfunction occurs in 2 continuous driving cycles.

6. DTC CLEAR CONDITION

- When the OK idling cycle is completed 40 times in a row
- When "Clear Memory" is performed

7. MALFUNCTION INDICATOR LIGHT CLEAR CONDITION

- When the OK driving cycle is completed 3 times in a row
- When "Clear Memory" is performed

8. FAIL SAFE

None

9. ECM OPERATION AT DTC SETTING

- Memorize the freeze frame data. (For test mode \$02)
- Memorize the diagnostic value and trouble standard value. (For test mode \$06)

BF:DTC P0442 EVAPORATIVE EMISSION CONTROL SYSTEM LEAK DETECTED (SMALL LEAK)

1. OUTLINE OF DIAGNOSIS

Check if there is a leakage in fuel system or not, and perform the function diagnosis of valve.

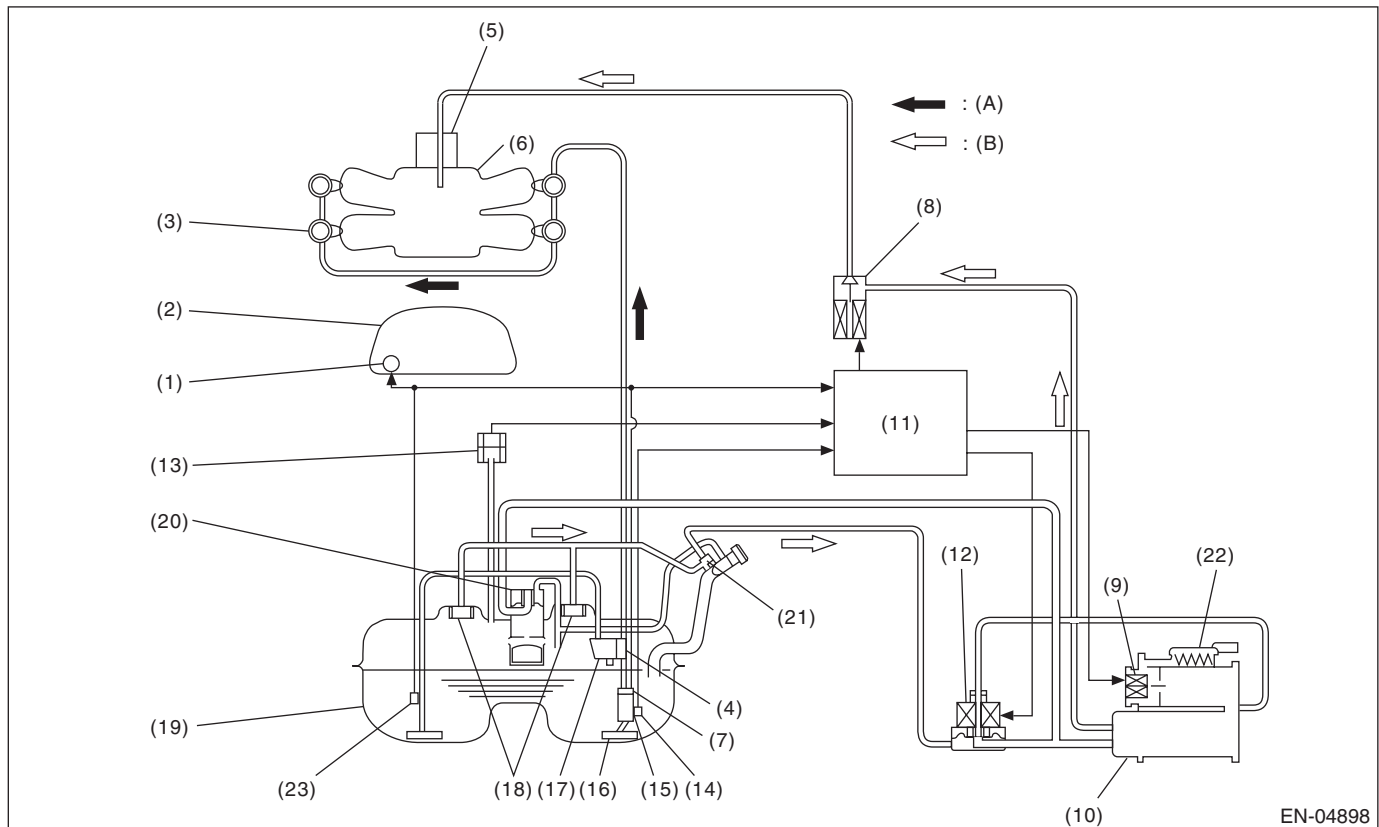

EN-04898

- | | | |
|----------------------------------|----------------------------------|----------------------------|
| (1) Fuel gauge | (10) Canister | (19) Fuel tank |
| (2) Combination meter | (11) Engine control module (ECM) | (20) Vent valve |
| (3) Fuel injector | (12) Pressure control valve | (21) Shut-off valve |
| (4) Pressure regulator | (13) Fuel tank pressure sensor | (22) Drain filter |
| (5) Throttle body | (14) Fuel temperature sensor | (23) Fuel sub level sensor |
| (6) Intake manifold | (15) Fuel level sensor | |
| (7) Fuel filter | (16) Fuel pump | (A) Fuel line |
| (8) Purge control solenoid valve | (17) Jet pump | (B) Vaporized fuel line |
| (9) Drain valve | (18) Fuel cut valve | |

In this system diagnosis, check for leakage and valve function is conducted by changing the fuel tank pressure and monitoring the pressure change using the fuel tank pressure sensor. During 0.04-inch diagnosis, perform in the order of mode Z → mode A → mode B → mode C and mode D; During 0.02-inch diagnosis, perform in the order of mode A → mode B → mode C → mode D and mode E.

Diagnostic Trouble Code (DTC) Detecting Criteria

GENERAL DESCRIPTION

0.04-INCH DIAGNOSIS

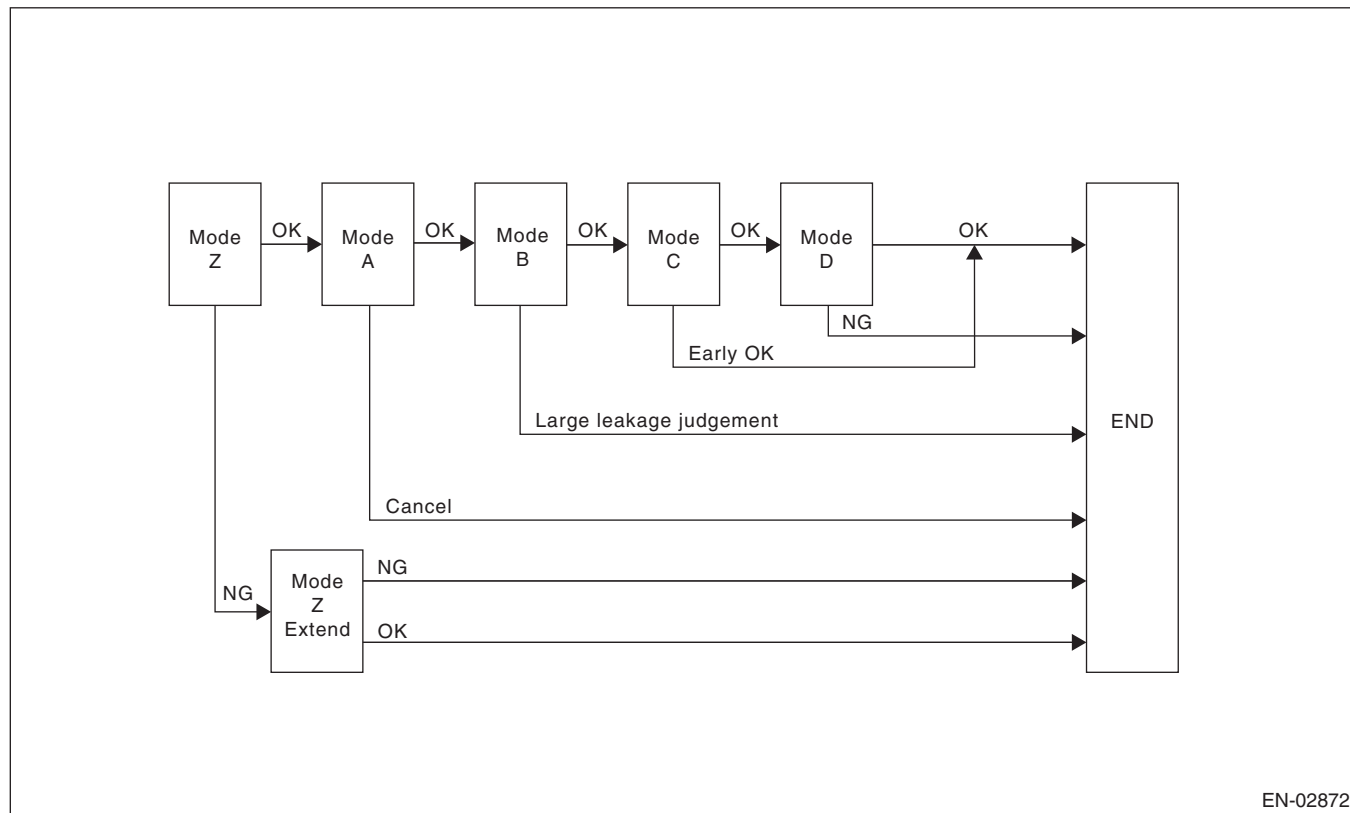

EN-02872

Mode	Mode description	Diagnosis period
Mode Z (Purge control solenoid valve opening failure diagnosis)	Perform purge control solenoid valve opening failure diagnosis from the size of tank pressure variation from diagnosis start.	3 — 16 seconds
Mode A (Estimated evaporation amount)	Calculate the tank pressure change amount (P1).	10 seconds
Mode B (Sealed negative pressure, large leakage judgment)	Decrease the pressure in the tank to the target value by introducing the intake manifold pressure to the fuel tank. If the tank pressure cannot be reduced, it is diagnosed as large leak.	5 — 25 seconds
Mode C (Pressure increase check, advanced OK judgment)	Wait until the tank pressure returns to the target (start level of P2 calculation). If the tank pressure does not become the value, make advanced OK judgment.	1 — 15 seconds
Mode D (Negative pressure variation measurement, evaporation leakage diagnosis)	Calculate the tank pressure variation (P2), and obtain the diagnostic value using P1 found in Mode A. Perform the evaporation diagnosis using the diagnostic value.	10 seconds

Mode Table for Evaporative Emission Control System Diagnosis

Mode	Tank internal pressure under normal conditions	Diagnostic item	DTC
Mode Z	Roughly the same as atmospheric pressure (Same as 0 kPa (0 mmHg, 0 inHg))	Purge control solenoid valve is judged to be open.	P0457
Mode A	Pressure is in proportion to amount of evaporative emission.		
Mode B	Negative pressure is formed due to intake manifold negative pressure.	Large leak	P0457
Mode C	Reaches target pressure		None
Mode D	Pressure change is small.	EVAP system large leak judgement [1.0 mm (0.04 in)]	P0442

Diagnostic Trouble Code (DTC) Detecting Criteria

GENERAL DESCRIPTION

0.02-inch Diagnosis

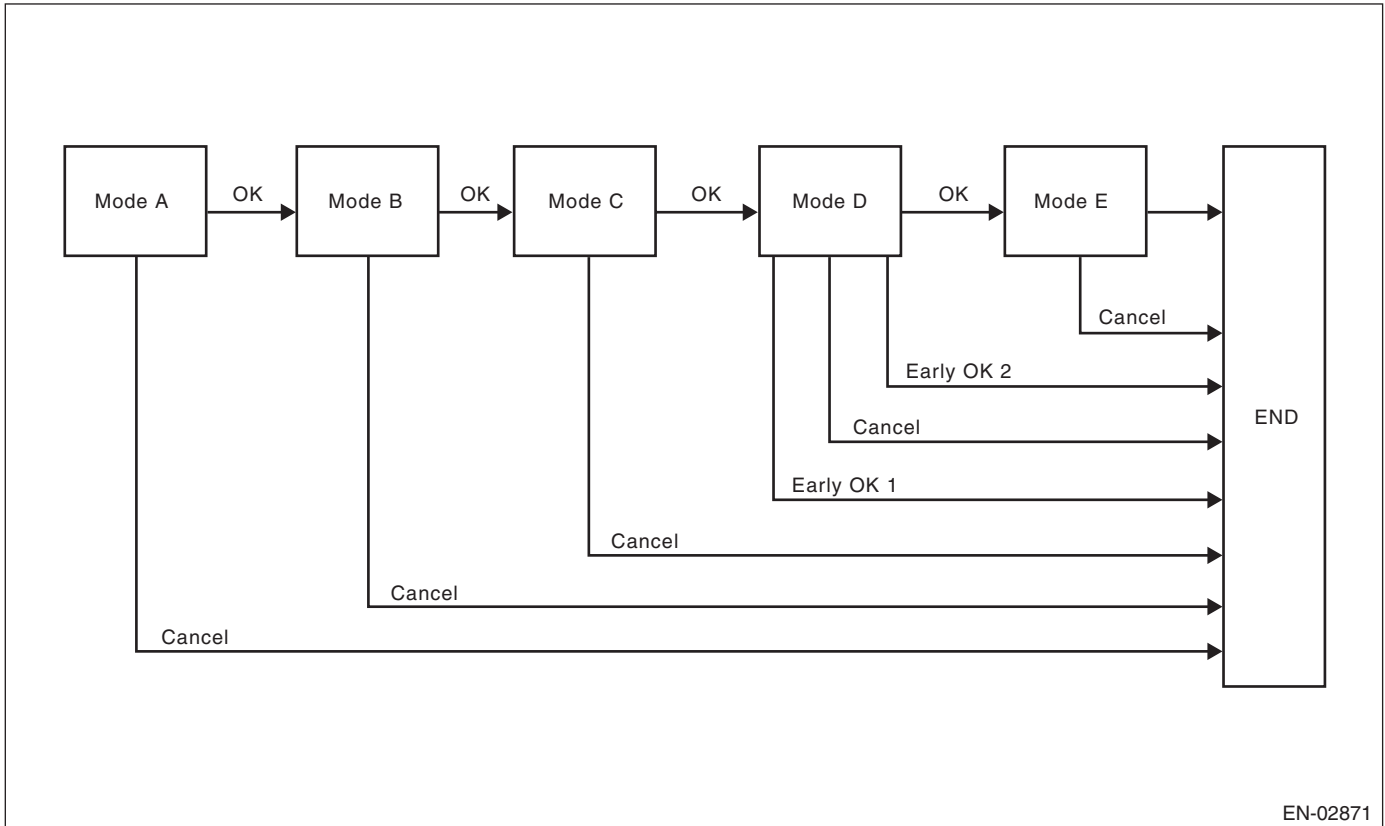

EN-02871

Mode	Mode Description	Diagnosis period
Mode A (0 point compensation)	When the pressure in the tank is high, wait until it returns to 0 point (Near 0 mmHg).	0 — 12 seconds
Mode B (Negative pressure introduced)	Decrease the pressure in the tank to the target value by introducing the intake manifold pressure to the fuel tank.	0 — 27 seconds
Mode C (Negative pressure maintained)	Wait until the tank pressure returns to the target (start level of P2 calculation).	0 — 20 seconds
Mode D (Negative pressure change calculated)	Calculate the time it takes for the tank pressure to return to the P2 calculation complete pressure. If the tank pressure does not return to the P2 calculation complete pressure, make advanced OK judgment.	0 — 200 seconds
Mode E (Evaporation generated amount calculated)	Calculate the amount of evaporation (P1).	0 — 280 seconds

2. COMPONENT DESCRIPTION

Pressure Control Solenoid Valve

PCV controls the fuel tank pressure to be equal to the atmospheric air pressure. Normally, the solenoid is set to OFF. The valve opens and closes mechanically in accordance with the pressure difference between tank and atmospheric air, or tank and canister.

Diagnostic Trouble Code (DTC) Detecting Criteria

GENERAL DESCRIPTION

The valve is forcibly opened by setting the solenoid to ON at the time of diagnosis.

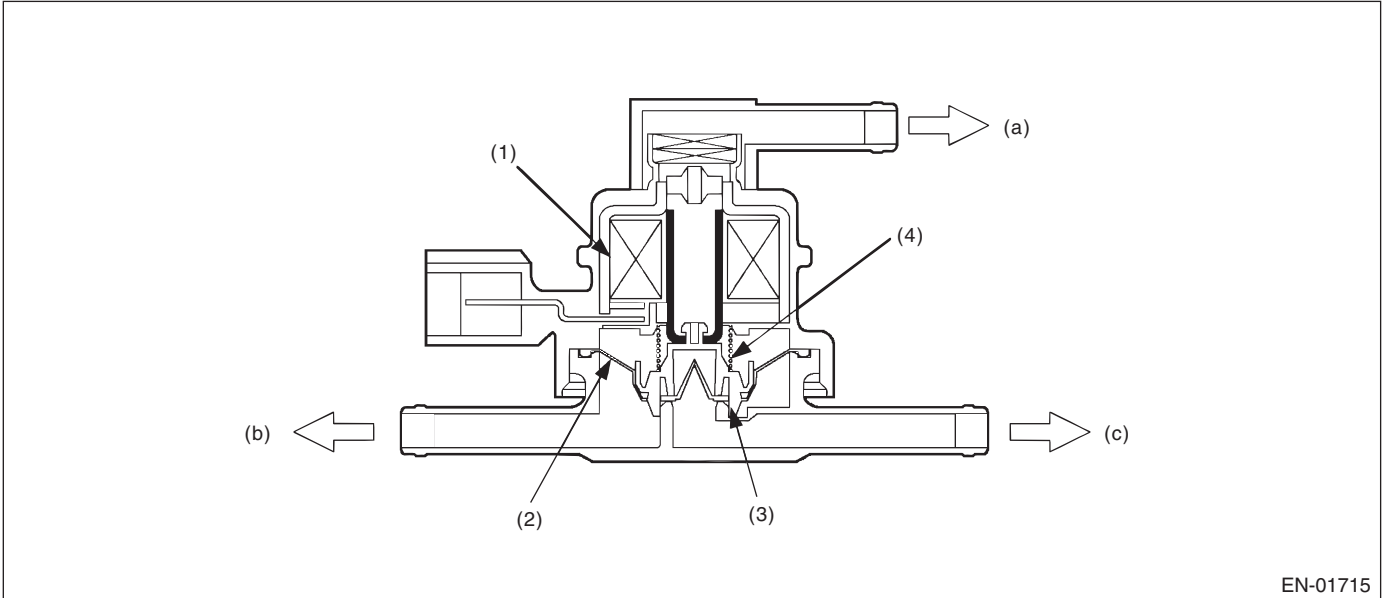

EN-01715

- | | | |
|---------------|------------|--------------------------|
| (1) Solenoid | (3) Valve | (a) Atmospheric pressure |
| (2) Diaphragm | (4) Spring | (b) Fuel tank |
| | | (c) Canister |

Valve Operation and Air Flow

In the figure below, divided by the diaphragm, the part above X is charged with atmospheric air pressure, and the part below X is charged with tank pressure. Also, the part above Y is charged with tank pressure, and the part below Y is charged with canister pressure.

If the atmospheric air pressure port is A, tank pressure port is B, and canister pressure port is C, the air flows according to pressure difference from each port as shown in the table below.

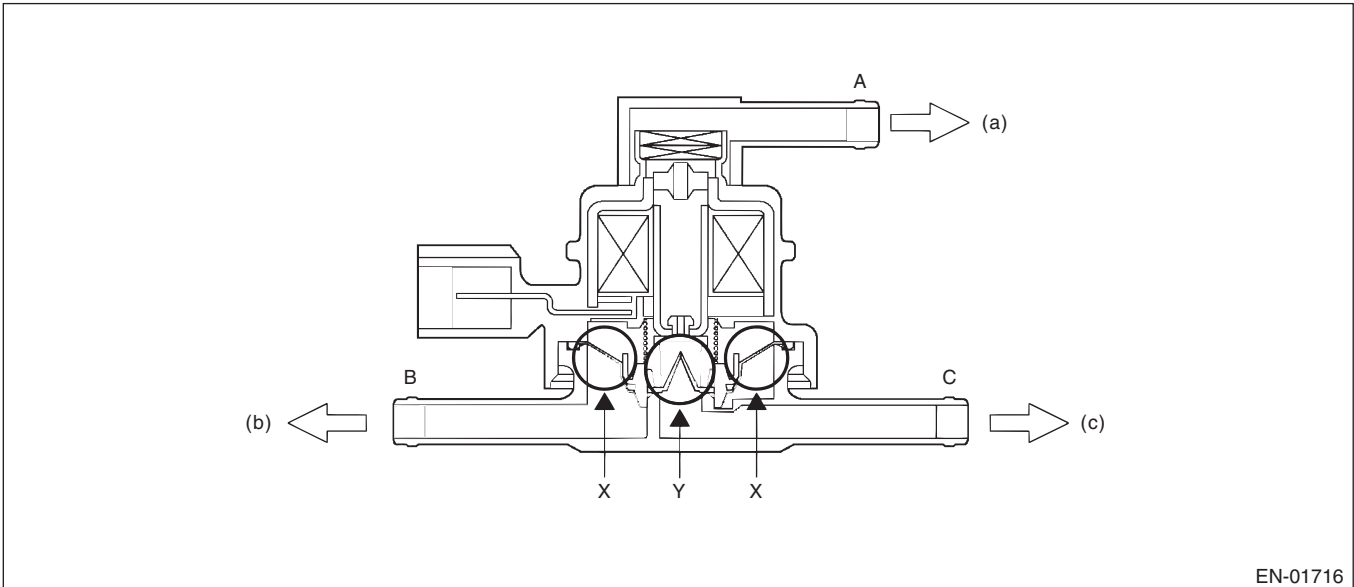

EN-01716

- | | | |
|--------------------------|---------------|--------------|
| (a) Atmospheric pressure | (b) Fuel tank | (c) Canister |
|--------------------------|---------------|--------------|

Condition of pressure	Flow
A < B (solenoid OFF)	B → C
B < C (solenoid OFF)	C → B
Solenoid ON	B ↔ C

Diagnostic Trouble Code (DTC) Detecting Criteria

GENERAL DESCRIPTION

When $A < B$ (Solenoid OFF)

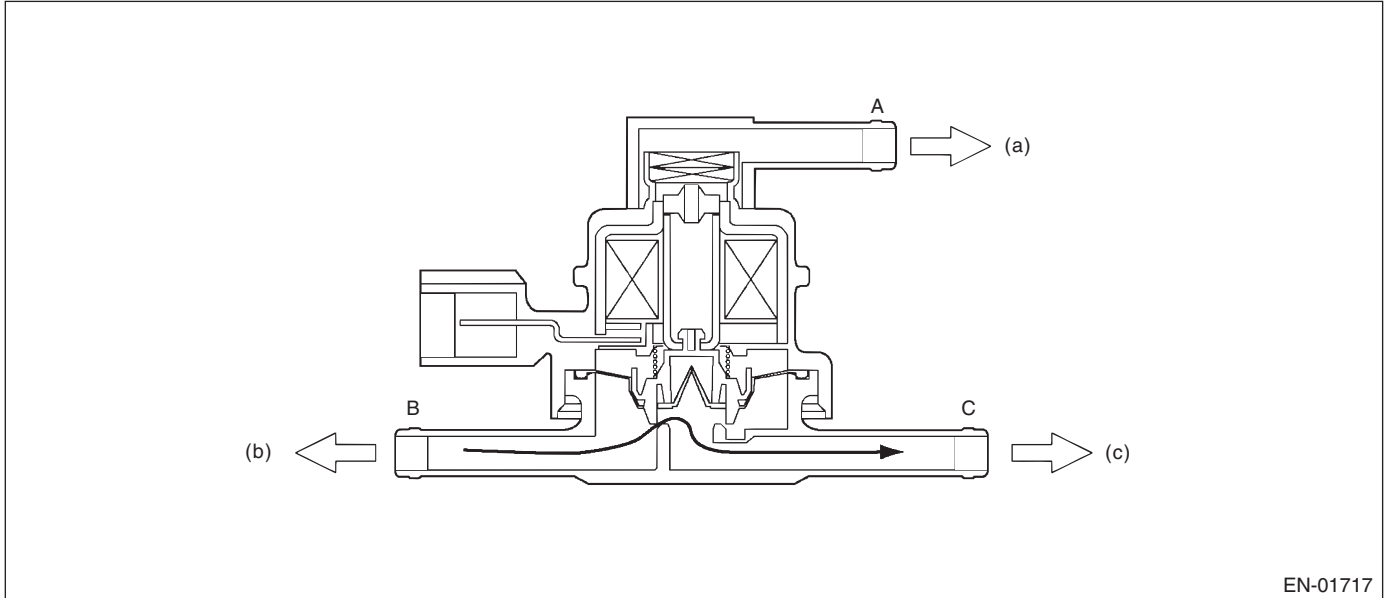

EN-01717

(a) Atmospheric pressure

(b) Fuel tank

(c) Canister

When $B < C$ (Solenoid OFF)

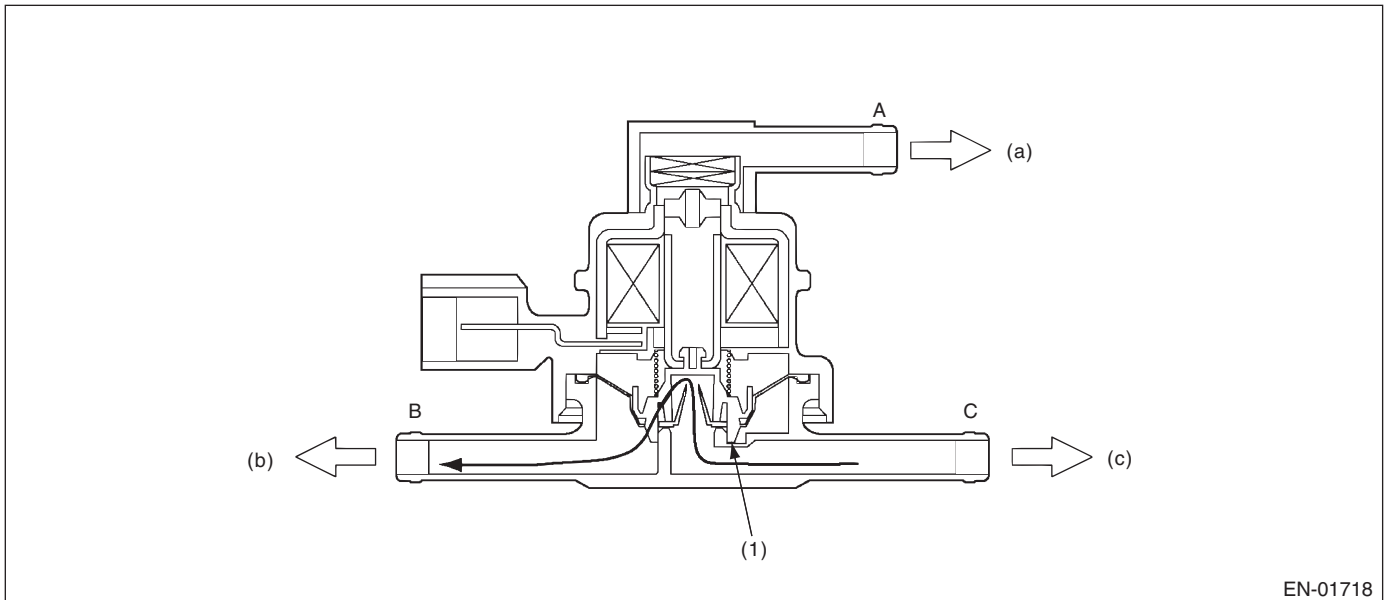

EN-01718

(1) Valve

(a) Atmospheric pressure

(b) Fuel tank

(c) Canister

Diagnostic Trouble Code (DTC) Detecting Criteria

GENERAL DESCRIPTION

When Solenoid is ON

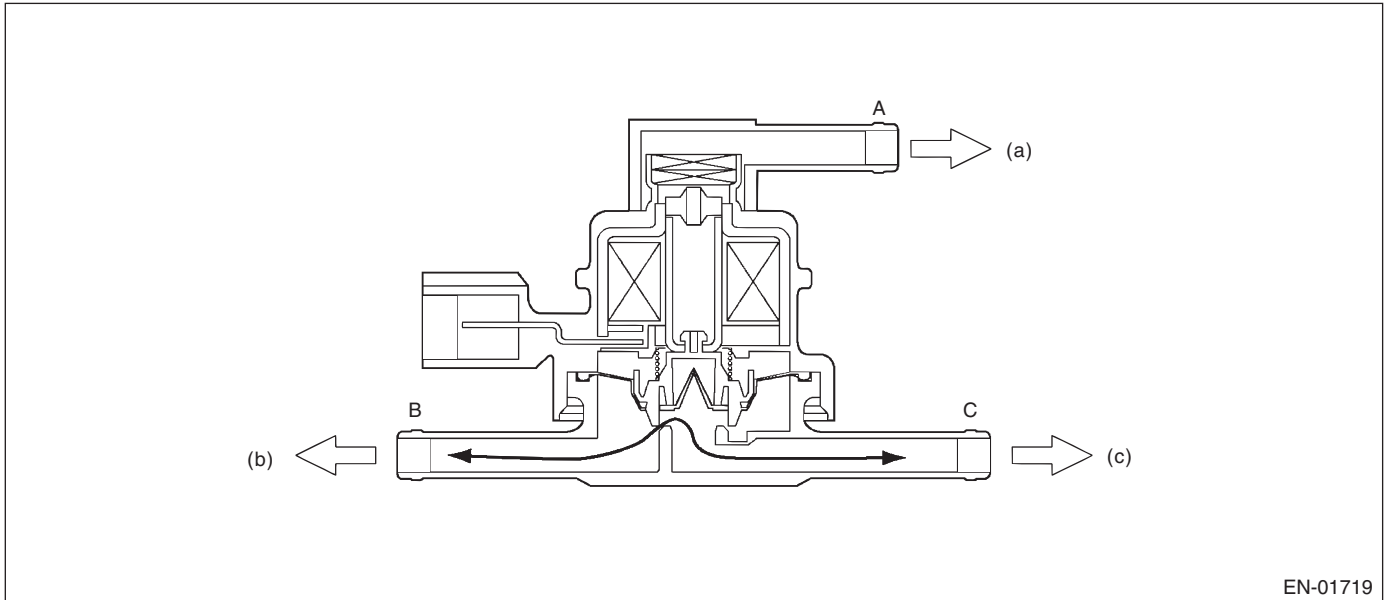

EN-01719

(a) Atmospheric pressure

(b) Fuel tank

(c) Canister

Drain Valve

Drain valve controls the ambient air to be introduced to the canister.

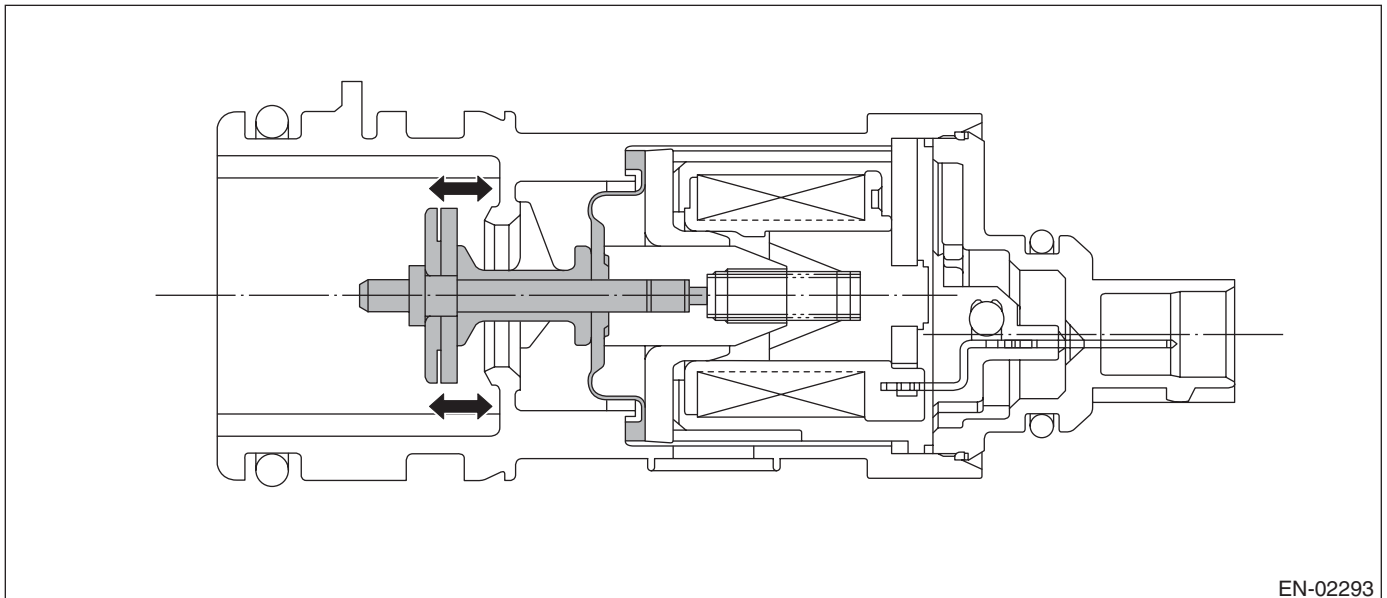

EN-02293

Diagnostic Trouble Code (DTC) Detecting Criteria

GENERAL DESCRIPTION

3. ENABLE CONDITION

0.04-inch Diagnosis

Secondary Parameters	Enable Conditions
Battery voltage	≥ 10.9 V
Barometric pressure	≥ 75.1 kPa (563 mmHg, 22.17 inHg)
Total time of canister purge operation	120 seconds or more
After engine starting	856 seconds or more
Learning value of evaporation gas density	≤ 0.08
Engine speed	1,050 — 6,000 rpm
Fuel tank pressure	≥ -4.00 kPa (-30 mmHg, -1.18 inHg)
Intake manifold vacuum (relative pressure)	< -26.7 kPa (-200 mmHg, -7.87 inHg)
Vehicle speed	≥ 32 km/h (20 MPH)
Fuel level	9.0 — 51.0 (2.38 — 13.47 US gal, 1.98 — 11.22 Imp gal)
Closed air/fuel ratio control	In operation
Fuel temperature	-10 — 45°C (14 — 113°F)
Intake air temperature	≥ -10 °C (14°F)
Pressure change per second	< 0.23 kPa (1.7 mmHg, 0.07 inHg)
Minimum pressure change value every one second – Maximum pressure change value every one second	< 0.23 kPa (1.7 mmHg, 0.07 inHg)
Change of fuel level	< 2.5 \varnothing /128 milliseconds (0.66 US gal/128 milliseconds, 0.55 Imp gal/128 milliseconds)
Air fuel ratio	0.76 — 1.25

Diagnostic Trouble Code (DTC) Detecting Criteria

GENERAL DESCRIPTION

0.02-inch Diagnosis

Secondary Parameters	Enable Condition
(At starting a diagnosis)	
Evap. diagnosis	Incomplete
Battery voltage	≥ 10.9 V
Atmospheric pressure	≥ 75.1 kPa (563 mmHg, 22.2 inHg)
Time from 0.02 inch leak, previous incomplete diagnosis	
When cancelling in mode A	> 120 sec.
When cancelling in other than mode A	> 600 sec.
Total time of canister purge operation	120 seconds or more
After engine starting	120 seconds or more
Fuel Temp.	-10 — 70°C (14 — 158°F)
Fuel level	9.0 — 51.0 ℓ (2.38 — 13.47 US gal, 1.98 — 11.22 Imp gal)
Intake manifold vacuum (relative pressure)	< -8.0 kPa (-60 mmHg, -2.36 inHg)
Fuel tank pressure	-0.67 — 1.43 kPa (-5 — 10.7 mmHg, -0.20 — 0.42 inHg)
Vehicle speed	≥ 30 km/h (19 MPH)
Closed air/fuel ratio control	In operation
Engine speed	550 — 6000 rpm
(During diagnosis)	
Change of fuel level	≤ Value from Map
Pressure change every one second	< 0.06 kPa (0.44 mmHg, 0.02 inHg)
Minimum pressure change value every one second —	< 0.07 kPa (0.51 mmHg, 0.02 inHg)
Maximum pressure change value every one second	
Pressure change in tank every second	≤ 0.1 kPa (0.75 mmHg, 0.03 inHg)
Atmospheric pressure change (Mode D)	-0.48 — 0.32 kPa (-3.6 — 2.4 mmHg, -0.14 — 0.09 inHg)
Atmospheric pressure change (Mode E)	-0.32 — 0.32 kPa (-2.4 — 2.4 mmHg, -0.09 — 0.09 inHg)

Map

Fuel level (ℓ , US gal, Imp gal)	0	10, 2.64, 2.2	20, 5.28, 4.4	30, 7.93, 6.6	40, 10.57, 8.8	50, 13.21, 11	60, 15.85, 13.2
Change (ℓ , US gal, Imp gal)	4.2, 1.11, 0.92	4.2, 1.11, 0.92	4.1, 1.08, 0.9	4.0, 1.06, 0.88	3.9, 1.03, 0.86	3.8, 1.0, 0.84	3.8, 1.0, 0.84

4. GENERAL DRIVING CYCLE

0.04-inch Diagnosis

- After 856 seconds or more have passed since the engine started, perform the diagnosis only once at a constant speed of 32 km/h (20 MPH) or more.
- Pay attention to the fuel temperature and fuel level.

0.02-inch Diagnosis

- After 770 seconds or more have passed since the engine started, perform the diagnosis at a constant speed of 68 km/h (42 MPH) or more, to judge as NG or OK.
- If judgment cannot be made, repeat the diagnosis.
- Be careful of the remaining fuel level.

5. DIAGNOSTIC METHOD

Purge control solenoid valve stuck open fault diagnosis

DTC

P0457 Evaporative Emission Control System Leak Detected (Fuel Cap Loose/Off)

Purpose of Mode Z

When performing the leakage diagnosis of EVAP system, the purge control solenoid valve must operate normally. Therefore, mode Z is used to diagnose the purge control solenoid valve stuck open condition. Note that if a purge control solenoid valve stuck open fault is detected, the EVAP system leakage diagnosis is cancelled.

Diagnostic method

Purge control solenoid valve functional diagnosis is performed by monitoring the tank pressure in mode Z.

Normality Judgment

Judge OK and change to Mode A when the criteria below are completed in 3 seconds after Mode Z started.

Judgment Value

Malfunction Criteria	Threshold Value	DTC
(Tank pressure when Mode Z started) – (Tank pressure when Mode Z finished)	≤ 0.4 kPa (3 mmHg, 0.12 inHg)	P0457

Normal

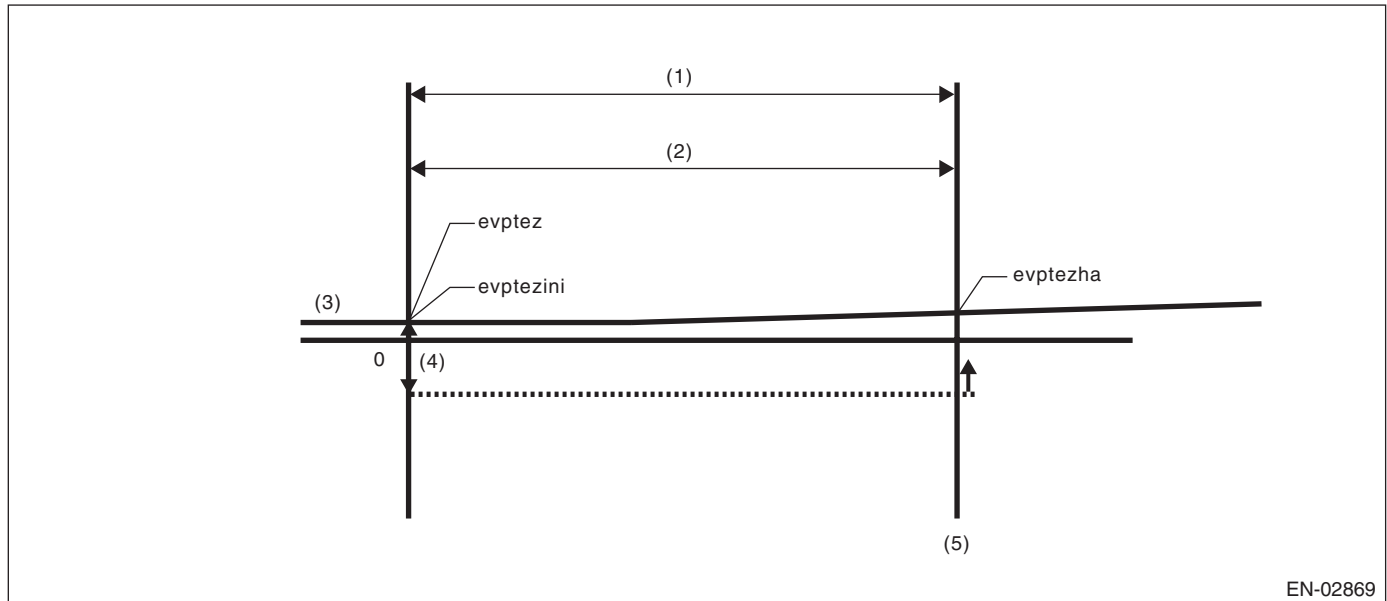

EN-02869

- | | | |
|---------------|-----------------------------------|-----------------|
| (1) Mode Z | (3) Fuel tank pressure | (5) OK judgment |
| (2) 3 seconds | (4) 0.4 kpa (3.0 mmHg, 0.12 inHg) | |

- $evptez - evptezha \leq 0.4 \text{ kPa (3.0 mmHg, 0.12 inHg)}$
- $evptezini - evptezha \leq 0.4 \text{ kPa (3.0 mmHg, 0.12 inHg)}$

Judge as normal when both are established.

Abnormality Judgment

If OK judgment cannot be made, extend Mode Z 16 seconds more, and judge as NG when all the criteria below are completed after 16 seconds.

Judgment Value

Malfunction Criteria	Threshold Value	DTC
(Tank pressure when Mode Z started) – (Tank pressure when Mode Z finished)	> 0.6 kPa (4.5 mmHg, 0.18 inHg)	P0457
Tank pressure when Mode Z started	≤ 1.43 kPa (10.7 mmHg, 0.42 inHg)	
Time of 2 0 or more fuel no sloshing	≥ 40 sec.	

Diagnostic Trouble Code (DTC) Detecting Criteria

GENERAL DESCRIPTION

Time Needed for Diagnosis: 16 seconds

Malfunction Indicator Light Illumination: Illuminates when malfunction occurs in 2 continuous driving cycles.

When judgment for purge control solenoid valve stuck open NG is made, end the evaporative diagnosis. Cancel the evaporative diagnosis when the OK/NG judgment for purge control solenoid valve stuck open cannot be made in Mode Z.

Purge Control Solenoid Valve Open Fixation

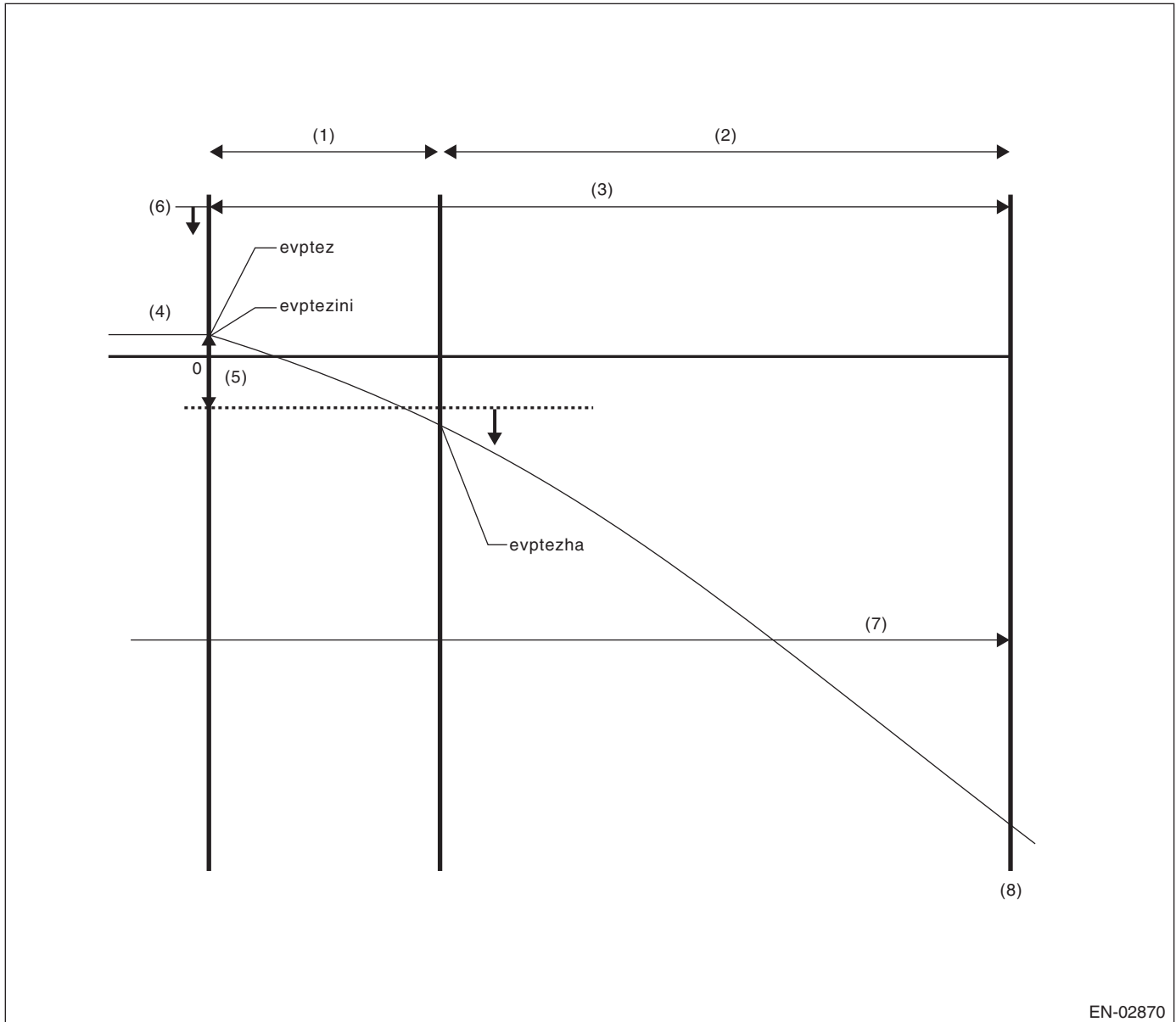

EN-02870

- | | | |
|---------------------|-------------------------------------|-------------------------------------|
| (1) Mode Z | (4) Fuel tank pressure | (7) No fuel sloshing for 40 seconds |
| (2) Extended mode Z | (5) 0.87 kpa (6.5 mmHg, 0.26 inHg) | (8) NG judgment |
| (3) 16 seconds | (6) 1.43 kpa (10.7 mmHg, 0.42 inHg) | |

- $evptezini, evptez \leq 1.43 \text{ kPa (10.7 mmHg, 0.42 inHg)}$
 - $evptez - evptezha \leq 0.87 \text{ kPa (6.5 mmHg, 0.26 inHg)}$
 - $evptezini - evptezha \leq 0.87 \text{ kPa (6.5 mmHg, 0.26 inHg)}$
 - No fuel sloshing of over 2 \varnothing (0.53 US gal, 0.44 Imp gal) for 40 seconds or more.
- Judge as normal when all are established.

Diagnostic Trouble Code (DTC) Detecting Criteria

GENERAL DESCRIPTION

Leak Diagnosis

DTC

P0442 Evaporative Emission Control System Leak Detected (Small Leak)

P0457 Evaporative Emission Control System Leak Detected (Fuel Cap Loose/Off)

Diagnostic method

- The diagnostic method consists of creating a sealed vacuum in the fuel tank and then determining the presence of leakage from the speed at which the tank internal pressure returns to atmospheric pressure.
- The diagnosis is divided into the following five phases.

Mode A: (Estimated evaporation gas amount)

Calculate the tank pressure change amount (P1) when using mode A. After calculating P1, switch to mode B.

Mode B: (Negative pressure sealed)

Introduce negative pressure in the intake manifold to the tank.

Approximately 0 → -1.4 kPa (0 → -10.5 mmHg, 0 → -0.41 inHg)

When the pressure above (desired negative pressure) is reached, enters Mode C.

In this case, if the tank pressure does not reach the target negative pressure, judge that there is a large leakage (10 seconds or 25 seconds) in the system and terminate the evaporative emission control system diagnosis.

Abnormality Judgment

Judge as NG (large leak) when the criteria below are met.

Judgment Value

Malfunction Criteria	Threshold Value	DTC
Time to reach target negative pressure Or mode B time (Min. pressure value in tank when in mode B) – (Tank pressure when mode B started)	≥ 25 sec. ≥ 10 sec. < -0.53 kPa (-4 mmHg, -0.16 inHg)	P0457

Mode C: (Check pressure rise)

Stop the introduction of negative pressure. (Wait until the tank pressure returns to the start level of P2 calculation.)

Change to Mode D when the tank pressure returns to the start level of P2 calculation.

Judge immediate OK and change to Mode E when it does not return in spite of spending the specified time.

Tank pressure when starting calculation of P2	Make advanced OK judgment
-1.3 kPa (-9.75 mmHg, -0.38 inHg)	15 seconds

Mode D: (Measure amount of negative pressure change)

Monitor the tank pressure change amount in mode D. In this case, the tank pressure increases (nears atmospheric pressure), because evaporation occurs. However, if any leakage exists, the pressure increases additionally in proportion to this leakage. The pressure variation of this tank is P2.

After calculating P2, perform a small leak diagnosis according to the items below.

When Mode D is ended

Assign tank variations measured in Mode A and Mode D; P1 and P2, to the formula below, judge small leaks in the system. If the measured judgment value exceeds the threshold value, it is judged to be a malfunction.

Diagnostic Trouble Code (DTC) Detecting Criteria

GENERAL DESCRIPTION

Abnormality Judgment

Judge as NG when the criteria below are met and judge as OK and clear NG when not met.

Judgment Value

Malfunction Criteria	Threshold Value	DTC
P2 – 1.5 × P1 P2: Tank pressure that changes every 10 seconds in mode D P1: Tank pressure that changes every 10 seconds in mode A	> Value from Map 7 * Threshold value: Map (Remaining Fuel vs Tank temperature)	P0442

* 1.5: Evaporation amount compensation value when below negative pressure (Amount of evaporation occurrence increases as a vacuum condition increases.)

Map 7 Malfunction criteria limit for evaporation diagnosis

Fuel temperature vs Fuel level	5°C (41°F)	15°C (59°F)	25°C (77°F)	35°C (95°F)	45°C (113°F)
10 ℓ (2.6 US gal, 2.2 Imp gal)	0.49 kPa (3.68 mmHg, 0.145 inHg)	0.49 kPa (3.68 mmHg, 0.145 inHg)	0.53 kPa (3.95 mmHg, 0.156 inHg)	0.54 kPa (4.07 mmHg, 0.160 inHg)	0.56 kPa (4.17 mmHg, 0.164 inHg)
20 ℓ (5.3 US gal, 4.4 Imp gal)	0.50 kPa (3.77 mmHg, 0.148 inHg)	0.51 kPa (3.79 mmHg, 0.149 inHg)	0.53 kPa (4.01 mmHg, 0.158 inHg)	0.56 kPa (4.17 mmHg, 0.164 inHg)	0.57 kPa (4.27 mmHg, 0.168 inHg)
30 ℓ (7.9 US gal, 6.6 Imp gal)	0.51 kPa (3.85 mmHg, 0.152 inHg)	0.52 kPa (3.9 mmHg, 0.154 inHg)	0.54 kPa (4.06 mmHg, 0.160 inHg)	0.57 kPa (4.27 mmHg, 0.168 inHg)	0.60 kPa (4.48 mmHg, 0.176 inHg)
40 ℓ (10.6 US gal, 8.8 Imp gal)	0.65 kPa (4.88 mmHg, 0.192 inHg)	0.65 kPa (4.90 mmHg, 0.193 inHg)	0.66 kPa (4.98 mmHg, 0.196 inHg)	0.71 kPa (5.32 mmHg, 0.209 inHg)	0.76 kPa (5.73 mmHg, 0.226 inHg)
50 ℓ (13.2 US gal, 11.0 Imp gal)	0.79 kPa (5.90 mmHg, 0.232 inHg)	0.79 kPa (5.90 mmHg, 0.232 inHg)	0.79 kPa (5.90 mmHg, 0.232 inHg)	0.85 kPa (6.38 mmHg, 0.251 inHg)	0.88 kPa (6.60 mmHg, 0.260 inHg)

Time Needed for Diagnosis: 30 to 100 seconds

Malfunction Indicator Light Illumination: Illuminates when malfunction occurs in 2 continuous driving cycles.

Leak Diagnosis

DTC

P0456 Evaporative Emission Control System Leak Detected (very small leak)

Diagnostic method

- The diagnostic method consists of creating a sealed vacuum in the fuel tank and then determining the presence of leakage from the speed at which the tank internal pressure returns to atmospheric pressure.
- The diagnosis is divided into the following five phases.

Mode A: (0 point compensation)

When the pressure in the tank is high, wait until it returns to 0 point (Near 0 mmHg.). Shift to mode B when returned to the 0 point. Cancel the diagnosis when 0 point does not return in the specified time.

Mode B: (Vacuum pressure introduction)

Introduce negative pressure in the intake manifold to the tank.
Approximately 0 → -2.0 kPa (0 → -15 mmHg, 0 → -0.59 inHg)

When the pressure above (desired negative pressure) is reached, enters Mode C.

At this time, if the tank internal pressure does not reach the target vacuum pressure, cancel the diagnosis.

Mode C: (Vacuum pressure maintained)

Stop the introduction of negative pressure. (Wait until the tank pressure returns to the start level of P2 calculation.)

Change to Mode D either when the tank pressure returns to the start level of P2 calculation, or when the pre-determined amount of time has passed.

Diagnostic Trouble Code (DTC) Detecting Criteria

GENERAL DESCRIPTION

Mode D: (Vacuum pressure change amount calculation)

Monitor the tank pressure in mode D, calculate (P2) the pressure change in the tank, and measure the time (evpdset) for the tank pressure to return when calculation of P2 is completed. Shift to Mode E when the tank pressure returns to the end level of P2 calculation. If it does not return to the P2 calculation end tank internal pressure after the predetermined amount of time has passed, make advanced OK judgment or cancel the diagnosis.

Normality Judgment

Judge as OK when the criteria below are met.

Judgment Value

Malfunction Criteria	Threshold Value
Advanced OK judgment 1	
Mode D time	≥ 30 sec.
Tank internal pressure	≤ -1.8 kPa (-13.4 mmHg, -0.53 inHg)
Advanced OK judgment 2	
Mode D time	≥ 200 sec.
P2	≤ 0.9 — 1.3 kPa (7 — 9.6 mmHg, 0.28 — 0.38 inHg)

Mode E: (Evaporation occurrence amount calculation)

Calculate the change of tank pressure with the time evpdset to judge as NG/OK according to the value of P1. (There are gray judgments.)

Abnormality Judgment

Judge as NG when the malfunction criteria below are met.

Judgment Value

Malfunction Criteria	Threshold Value
P1	< Value from Map 7 * Threshold value: Map (Remaining fuel vs evpdset)

Map 7 Malfunction criteria limit for evaporation diagnosis

Time (evpdset) vs fuel level	0 seconds	30 seconds	80 seconds	100 seconds	150 seconds	200 seconds
10 ℓ (2.6 US gal, 2.2 Imp gal)	0 kPa (0 mmHg, 0 inHg)	0.21 kPa (1.6 mmHg, 0.063 inHg)	0.29 kPa (2.2 mmHg, 0.087 inHg)	0.29 kPa (2.2 mmHg, 0.087 inHg)	0.29 kPa (2.2 mmHg, 0.087 inHg)	0.29 kPa (2.2 mmHg, 0.087 inHg)
30 ℓ (7.9 US gal, 6.6 Imp gal)	0 kPa (0 mmHg, 0 inHg)	0.21 kPa (1.6 mmHg, 0.063 inHg)	0.29 kPa (2.2 mmHg, 0.087 inHg)	0.29 kPa (2.2 mmHg, 0.087 inHg)	0.29 kPa (2.2 mmHg, 0.087 inHg)	0 kPa (0 mmHg, 0 inHg)
50 ℓ (13.2 US gal, 11.0 Imp gal)	0 kPa (0 mmHg, 0 inHg)	0.24 kPa (1.8 mmHg, 0.071 inHg)	0.29 kPa (2.2 mmHg, 0.087 inHg)	0.29 kPa (2.2 mmHg, 0.087 inHg)	0 kPa (0 mmHg, 0 inHg)	0 kPa (0 mmHg, 0 inHg)

Diagnostic Trouble Code (DTC) Detecting Criteria

GENERAL DESCRIPTION

Normality Judgment

Judge as OK when the criteria below are met.

Judgment Value

Malfunction Criteria	Threshold Value
P1	> Value from Map 8 * Threshold value: Map (Remaining fuel vs evpdset)

Map 8 Malfunction criteria limit for evaporation diagnosis

Time (evpdset) vs fuel level	0 seconds	30 seconds	80 seconds	100 seconds	150 seconds	200 seconds
10 ℓ (2.6 US gal, 2.2 Imp gal)	0.16 kPa (1.2 mmHg, 0.047 inHg)	0.37 kPa (2.8 mmHg, 0.110 inHg)	0.45 kPa (3.4 mmHg, 0.134 inHg)	0.45 kPa (3.4 mmHg, 0.134 inHg)	0.45 kPa (3.4 mmHg, 0.134 inHg)	0.45 kPa (3.4 mmHg, 0.134 inHg)
30 ℓ (7.9 US gal, 6.6 Imp gal)	0.16 kPa (1.2 mmHg, 0.047 inHg)	0.37 kPa (2.8 mmHg, 0.110 inHg)	0.45 kPa (3.4 mmHg, 0.134 inHg)	0.45 kPa (3.4 mmHg, 0.134 inHg)	0.45 kPa (3.4 mmHg, 0.134 inHg)	0.45 kPa (3.4 mmHg, 0.134 inHg)
50 ℓ (13.2 US gal, 11.0 Imp gal)	0.16 kPa (1.2 mmHg, 0.047 inHg)	0.40 kPa (3 mmHg, 0.118 inHg)	0.45 kPa (3.4 mmHg, 0.134 inHg)	0.45 kPa (3.4 mmHg, 0.134 inHg)	0.45 kPa (3.4 mmHg, 0.134 inHg)	0.45 kPa (3.4 mmHg, 0.134 inHg)

Time Needed for Diagnosis: 65 to 514 seconds

Malfunction Indicator Light Illumination: Illuminates when malfunction occurs in 2 continuous driving cycles.

6. DTC CLEAR CONDITION

- When the OK idling cycle is completed 40 times in a row
- When "Clear Memory" is performed

7. MALFUNCTION INDICATOR LIGHT CLEAR CONDITION

- When the OK driving cycle is completed 3 times in a row
- When "Clear Memory" is performed

8. FAIL SAFE

None

9. ECM OPERATION AT DTC SETTING

- Memorize the freeze frame data. (For test mode \$02)
- Memorize the diagnostic value and trouble standard value. (For test mode \$06)

Diagnostic Trouble Code (DTC) Detecting Criteria

GENERAL DESCRIPTION

BG:DTC P0447 EVAPORATIVE EMISSION CONTROL SYSTEM VENT CONTROL CIRCUIT OPEN

1. OUTLINE OF DIAGNOSIS

Detect open or short circuit of the drain valve.

Judge as NG when the ECM output level differs from the actual terminal level.

2. COMPONENT DESCRIPTION

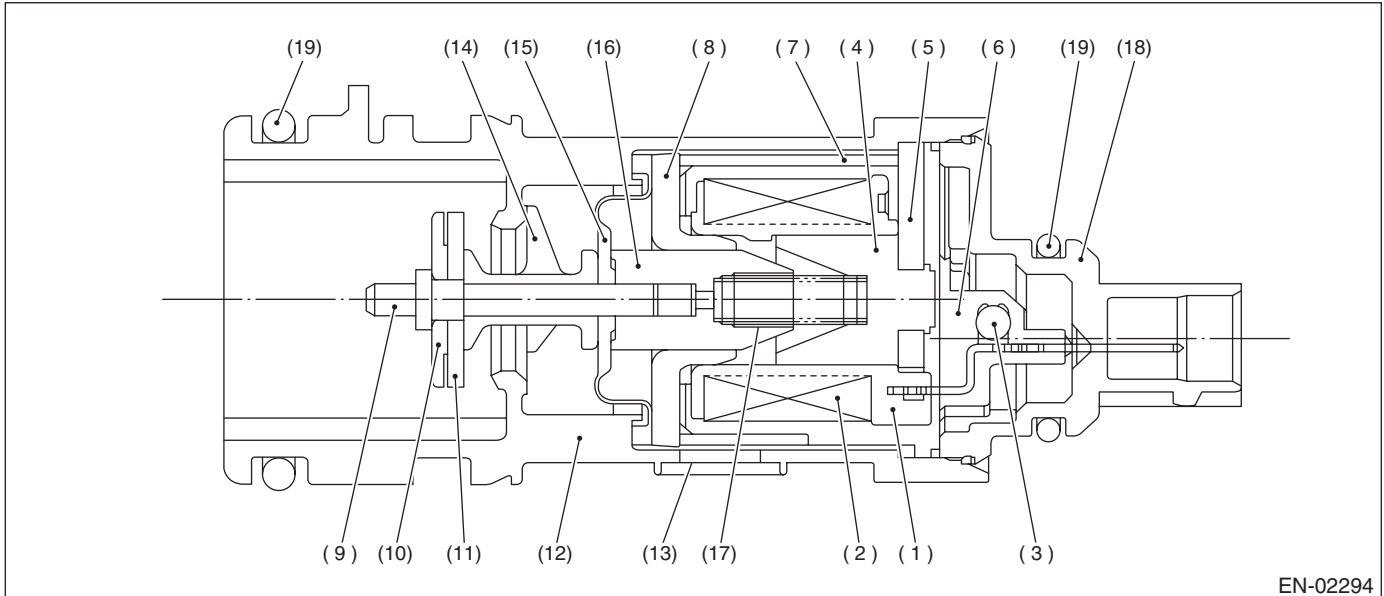

- | | | |
|-----------------|--------------------|-------------------|
| (1) Bobbin | (8) Magnetic plate | (14) Retainer |
| (2) Coil | (9) Shaft | (15) Diaphragm |
| (3) Diode | (10) Plate | (16) Movable core |
| (4) Stator core | (11) Valve | (17) Spring |
| (5) End plate | (12) Housing | (18) Cover |
| (6) Body | (13) Filter | (19) O-ring |
| (7) Yoke | | |

3. ENABLE CONDITION

Secondary Parameters	Enable Conditions
None	

4. GENERAL DRIVING CYCLE

Always perform the diagnosis continuously.

Diagnostic Trouble Code (DTC) Detecting Criteria

GENERAL DESCRIPTION

5. DIAGNOSTIC METHOD

Abnormality Judgment

Judge as NG when the continuous time of meeting all the malfunction criteria below becomes more than 2.5 seconds.

Judgment Value

Malfunction Criteria	Threshold Value
Ignition switch	ON
Battery voltage	≥ 10.9 V
After engine starting	1 second or more
Terminal output voltage when ECM outputs OFF signal	Low

Time Needed for Diagnosis: 2.5 seconds

Malfunction Indicator Light Illumination: Illuminates as soon as a malfunction occurs.

Normality Judgment

Judge as OK and clear the NG when all the malfunction criteria below are met.

Judgment Value

Malfunction Criteria	Threshold Value
Ignition switch	ON
Battery voltage	≥ 10.9 V
After engine starting	1 second or more
Terminal output voltage when ECM outputs OFF signal	High

6. DTC CLEAR CONDITION

- When the OK idling cycle is completed 40 times in a row
- When "Clear Memory" is performed

7. MALFUNCTION INDICATOR LIGHT CLEAR CONDITION

- When the OK driving cycle is completed 3 times in a row
- When "Clear Memory" is performed

8. FAIL SAFE

Pressure control solenoid valve control: Open the pressure control solenoid valve.

9. ECM OPERATION AT DTC SETTING

Memorize the freeze frame data. (For test mode \$02)

Diagnostic Trouble Code (DTC) Detecting Criteria

GENERAL DESCRIPTION

BH:DTC P0448 EVAPORATIVE EMISSION CONTROL SYSTEM VENT CONTROL CIRCUIT SHORTED

1. OUTLINE OF DIAGNOSIS

Detect open or short circuit of the drain valve.

Judge as NG when the ECM output level differs from the actual terminal level.

2. COMPONENT DESCRIPTION

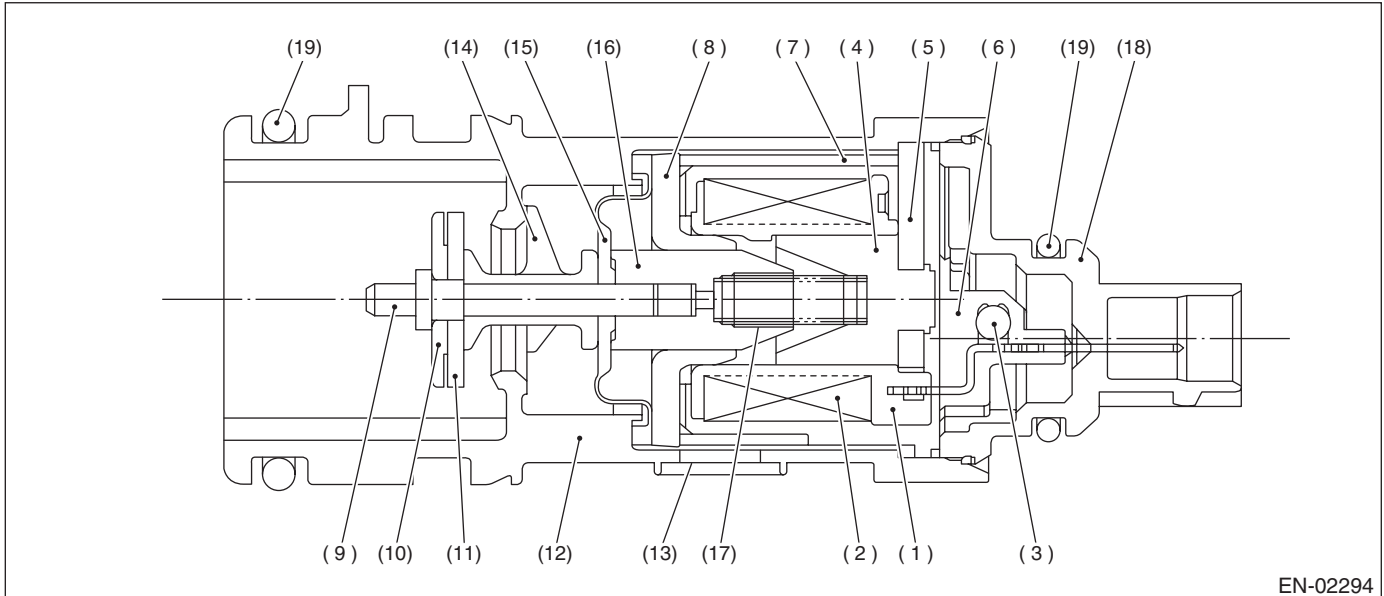

- | | | |
|-----------------|--------------------|-------------------|
| (1) Bobbin | (8) Magnetic plate | (14) Retainer |
| (2) Coil | (9) Shaft | (15) Diaphragm |
| (3) Diode | (10) Plate | (16) Movable core |
| (4) Stator core | (11) Valve | (17) Spring |
| (5) End plate | (12) Housing | (18) Cover |
| (6) Body | (13) Filter | (19) O-ring |
| (7) Yoke | | |

3. ENABLE CONDITION

Secondary Parameters	Enable Conditions
None	

4. GENERAL DRIVING CYCLE

Always perform the diagnosis continuously.

Diagnostic Trouble Code (DTC) Detecting Criteria

GENERAL DESCRIPTION

5. DIAGNOSTIC METHOD

Abnormality Judgment

Judge as NG when the continuous time of meeting the malfunction criteria below becomes more than 2.5 seconds.

Judgment Value

Malfunction Criteria	Threshold Value
Ignition switch	ON
Battery voltage	≥ 10.9 V
After engine starting	1 second or more
Terminal output voltage when ECM outputs ON signal	High

Time Needed for Diagnosis: 2.5 seconds

Malfunction Indicator Light Illumination: Illuminates as soon as a malfunction occurs.

Normality Judgment

Judge as OK and clear the NG when all the malfunction criteria below are met.

Judgment Value

Malfunction Criteria	Threshold Value
Ignition switch	ON
Battery voltage	≥ 10.9 V
After engine starting	1 second or more
Terminal output voltage when ECM outputs ON signal	Low

6. DTC CLEAR CONDITION

- When the OK idling cycle is completed 40 times in a row
- When "Clear Memory" is performed

7. MALFUNCTION INDICATOR LIGHT CLEAR CONDITION

- When the OK driving cycle is completed 3 times in a row
- When "Clear Memory" is performed

8. FAIL SAFE

Pressure control solenoid valve control: Open the pressure control solenoid valve.

9. ECM OPERATION AT DTC SETTING

Memorize the freeze frame data. (For test mode \$02)

Diagnostic Trouble Code (DTC) Detecting Criteria

GENERAL DESCRIPTION

BI: DTC P0451 EVAPORATIVE EMISSION CONTROL SYSTEM PRESSURE SENSOR

1. OUTLINE OF DIAGNOSIS

Detect the tank pressure sensor output property abnormality.

If there is no variation of tank internal pressure when there should be under the operating condition, judge as NG.

2. COMPONENT DESCRIPTION

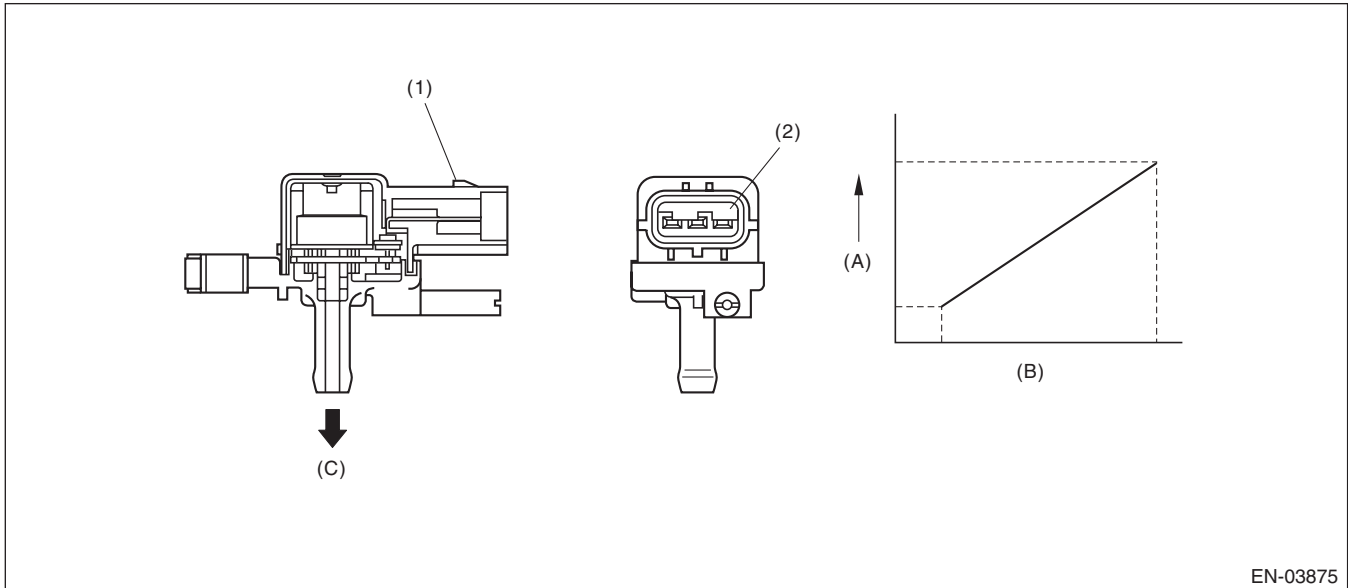

- (1) Connector
(2) Terminals

- (A) Output voltage
(B) Input voltage

- (C) To fuel tank

3. ENABLE CONDITION

Secondary Parameters	Enable Conditions
After engine starting	60 seconds or more
Fuel level	$\geq 9.0 \text{ l}$ (2.4 US gal, 2.0 Imp gal)
Fuel temperature	$< 35^{\circ}\text{C}$ (95°F)
Battery voltage	$\geq 10.9 \text{ V}$
Atmospheric pressure	$> 75.1 \text{ kPa}$ (563 mmHg, 22.2 inHg)

4. GENERAL DRIVING CYCLE

- Perform the diagnosis continuously after 60 seconds or more have passed since the engine started.
- Be sure to check the fuel level and fuel temperature.

Diagnostic Trouble Code (DTC) Detecting Criteria

GENERAL DESCRIPTION

5. DIAGNOSTIC METHOD

Abnormality Judgment

Judge as NG when the malfunction criteria below are met.

Judgment Value

Malfunction Criteria	Threshold Value
Number of times when the difference between the maximum value and minimum value for the fuel level every 60 seconds is 2 ℓ (0.53 US gal, 0.44 Imp gal) or more (with enable conditions established)	≥ 16 times
Maximum – Minimum tank pressure (with enable conditions established)	< 0.05 kPa (0.375 mmHg, 0.01 inHg)
Maximum – Minimum fuel temperature (with enable condition completed)	≥ 7°C (12.6°F)

If the maximum value – minimum value for the fuel level every 60 seconds is less than 2 liters, extend 60 seconds and make judgment with the maximum and minimum values for the fuel level in 120 seconds. If a difference does not appear though the time was extended 60 seconds, extend the time (180, 240, 300 seconds) and continue the judgment. If the maximum value – minimum value for the fuel level is 2 liters or more, the diagnosis counter counts up.

Time Needed for Diagnosis: 1 minute × 16 times or more

Malfunction Indicator Light Illumination: Illuminates when malfunction occurs in 2 continuous driving cycles.

Normality Judgment

Judge as OK and clear the NG when the malfunction criteria below are met.

Judgment Value

Malfunction Criteria	Threshold Value
Maximum – Minimum tank pressure	≥ 0.05 kPa (0.375 mmHg, 0.01 inHg)

6. DTC CLEAR CONDITION

- When the OK idling cycle is completed 40 times in a row
- When “Clear Memory” is performed

7. MALFUNCTION INDICATOR LIGHT CLEAR CONDITION

- When the OK driving cycle is completed 3 times in a row
- When “Clear Memory” is performed

8. FAIL SAFE

Purge control solenoid valve control: Not allowed to purge fixed mode.

9. ECM OPERATION AT DTC SETTING

Memorize the freeze frame data. (For test mode \$02)

BJ:DTC P0452 EVAPORATIVE EMISSION CONTROL SYSTEM PRESSURE SENSOR LOW INPUT

1. OUTLINE OF DIAGNOSIS

Detect the open or short circuit of the fuel tank pressure sensor.
Judge as NG if it is out of specification.

2. COMPONENT DESCRIPTION

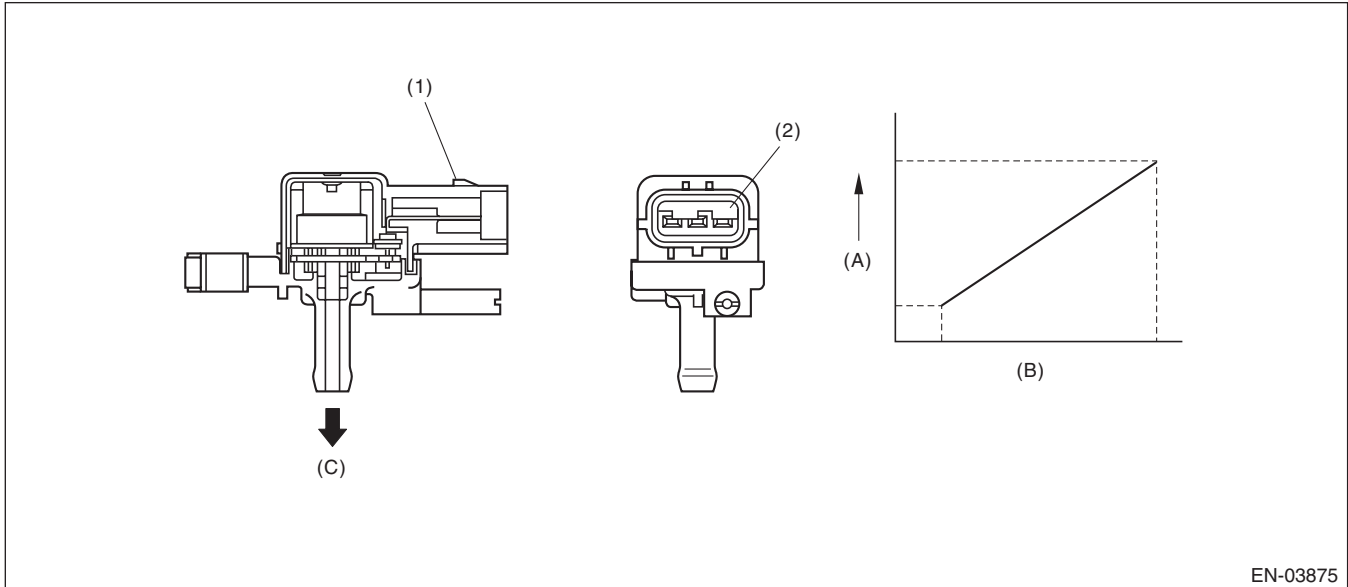

EN-03875

- (1) Connector
- (2) Terminals

- (A) Output voltage
- (B) Input voltage

- (C) To fuel tank

3. ENABLE CONDITION

Secondary Parameters	Enable Conditions
Battery voltage	$\geq 10.9 \text{ V}$

4. GENERAL DRIVING CYCLE

Always perform the diagnosis continuously.

Diagnostic Trouble Code (DTC) Detecting Criteria

GENERAL DESCRIPTION

5. DIAGNOSTIC METHOD

Abnormality Judgment

Judge as NG when the continuous time of meeting the malfunction criteria below becomes 15 seconds or more.

Judgment Value

Malfunction Criteria	Threshold Value
Fuel tank pressure	≤ -7.48 kPa (-56.15 mmHg, -2.21 inHg)

Time Needed for Diagnosis: 15 seconds

Malfunction Indicator Light Illumination: Illuminates as soon as a malfunction occurs.

Normality Judgment

Judge as OK when the criteria below are met.

Judgment Value

Malfunction Criteria	Threshold Value
Fuel tank pressure	> -7.48 kPa (-56.15 mmHg, -2.21 inHg)

6. DTC CLEAR CONDITION

- When the OK idling cycle is completed 40 times in a row
- When "Clear Memory" is performed

7. MALFUNCTION INDICATOR LIGHT CLEAR CONDITION

- When the OK driving cycle is completed 3 times in a row
- When "Clear Memory" is performed

8. FAIL SAFE

Purge control solenoid valve control: Not allowed to purge fixed mode.

9. ECM OPERATION AT DTC SETTING

Memorize the freeze frame data. (For test mode \$02)

BK:DTC P0453 EVAPORATIVE EMISSION CONTROL SYSTEM PRESSURE SENSOR HIGH INPUT

1. OUTLINE OF DIAGNOSIS

Detect the open or short circuit of the fuel tank pressure sensor.
Judge as NG if it is out of specification.

2. COMPONENT DESCRIPTION

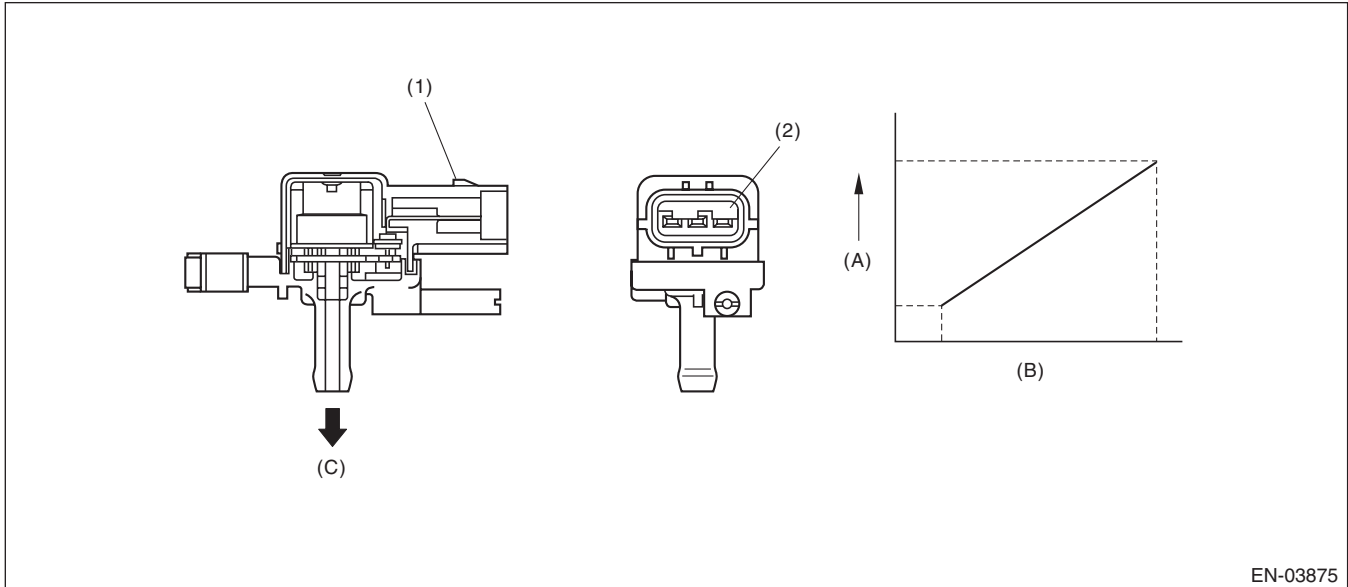

EN-03875

- | | | |
|---------------|--------------------|------------------|
| (1) Connector | (A) Output voltage | (C) To fuel tank |
| (2) Terminals | (B) Input voltage | |

3. ENABLE CONDITION

Secondary Parameters	Enable Conditions
Vehicle speed	≥ 2 km/h (1 MPH)
All conditions of EVAP canister purge	Completed
Learning value of evaporation gas density	≤ 0.08
Main feedback compensation coefficient	≥ 0.9
Battery voltage	≥ 10.9 V

4. GENERAL DRIVING CYCLE

Perform the diagnosis continually when purging.

Diagnostic Trouble Code (DTC) Detecting Criteria

GENERAL DESCRIPTION

5. DIAGNOSTIC METHOD

Abnormality Judgment

Judge as NG when the continuous time of meeting the malfunction criteria below becomes 15 seconds or more.

Judgment Value

Malfunction Criteria	Threshold Value
Fuel tank pressure	> 7.98 kPa (59.85 mmHg, 2.36 inHg)
Fuel temperature	< 35°C (95°F)
Atmospheric pressure	≥ 75.1 kPa (563 mmHg, 22.2 inHg)

Time Needed for Diagnosis: 15 seconds

Malfunction Indicator Light Illumination: Illuminates as soon as a malfunction occurs.

Normality Judgment

Judge as OK when the criteria below are met.

Judgment Value

Malfunction Criteria	Threshold Value
Fuel tank pressure	≤ 7.98 kPa (59.85 mmHg, 2.36 inHg)

6. DTC CLEAR CONDITION

- When the OK idling cycle is completed 40 times in a row
- When "Clear Memory" is performed

7. MALFUNCTION INDICATOR LIGHT CLEAR CONDITION

- When the OK driving cycle is completed 3 times in a row
- When "Clear Memory" is performed

8. FAIL SAFE

Purge control solenoid valve control: Not allowed to purge fixed mode.

9. ECM OPERATION AT DTC SETTING

Memorize the freeze frame data. (For test mode \$02)

Diagnostic Trouble Code (DTC) Detecting Criteria

GENERAL DESCRIPTION

BL:DTC P0456 EVAPORATIVE EMISSION CONTROL SYSTEM LEAK DETECTED (VERY SMALL LEAK)

NOTE:

For the detection standard, refer to DTC P0442 “EVAPORATIVE EMISSION CONTROL SYSTEM LEAK DETECTED (SMALL LEAK)”. <Ref. to GD(H4SO)-119, DTC P0442 EVAPORATIVE EMISSION CONTROL SYSTEM LEAK DETECTED (SMALL LEAK), Diagnostic Trouble Code (DTC) Detecting Criteria.>

BM:DTC P0457 EVAPORATIVE EMISSION CONTROL SYSTEM LEAK DETECTED (FUEL CAP LOOSE/OFF)

NOTE:

For the detection standard, refer to DTC P0442 “EVAPORATIVE EMISSION CONTROL SYSTEM LEAK DETECTED (SMALL LEAK)”. <Ref. to GD(H4SO)-119, DTC P0442 EVAPORATIVE EMISSION CONTROL SYSTEM LEAK DETECTED (SMALL LEAK), Diagnostic Trouble Code (DTC) Detecting Criteria.>

Diagnostic Trouble Code (DTC) Detecting Criteria

GENERAL DESCRIPTION

BN:DTC P0458 EVAPORATIVE EMISSION SYSTEM PURGE CONTROL VALVE CIRCUIT LOW

1. OUTLINE OF DIAGNOSIS

Detect open or short circuit of the purge control solenoid valve.

Judge as NG when the ECM output level differs from the actual terminal level.

2. COMPONENT DESCRIPTION

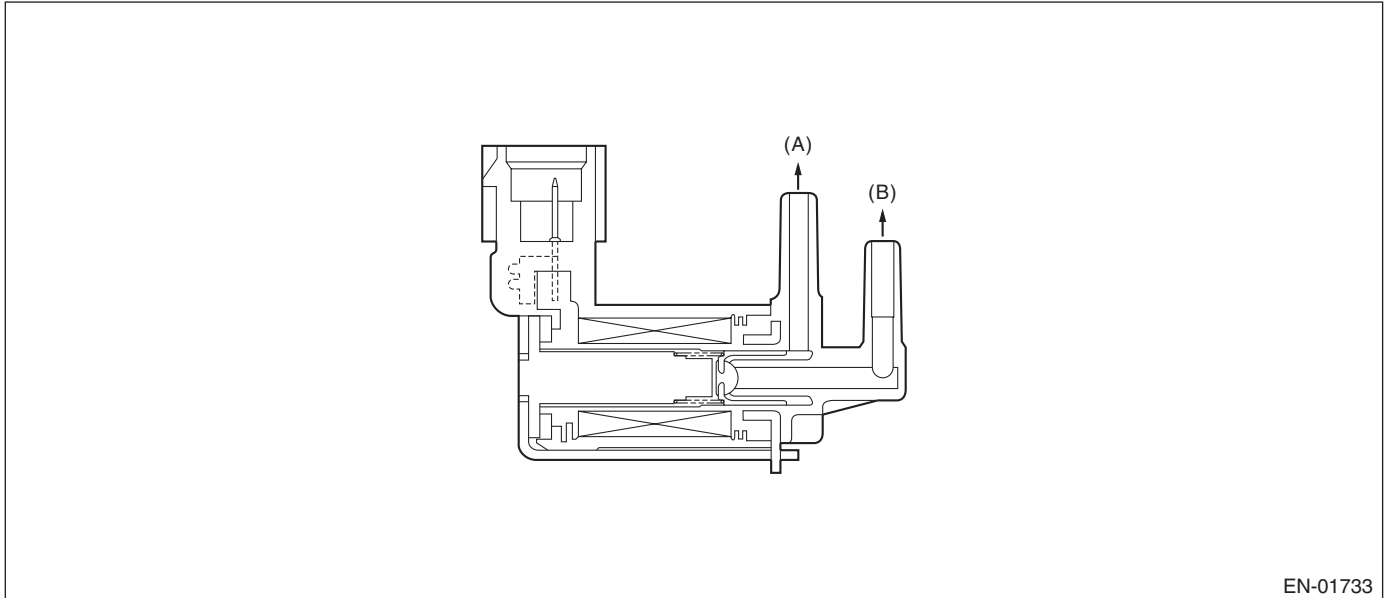

EN-01733

(A) To canister

(B) To intake manifold

3. ENABLE CONDITION

Secondary Parameters	Enable Conditions
Ignition switch	ON
Battery voltage	≥ 10.9 V
After engine starting	1 second or more

4. GENERAL DRIVING CYCLE

Always perform the diagnosis after starting the engine.

Diagnostic Trouble Code (DTC) Detecting Criteria

GENERAL DESCRIPTION

5. DIAGNOSTIC METHOD

Abnormality Judgment

Judge as NG when the malfunction criteria below are met.

Judgment Value

Malfunction Criteria	Threshold Value
Continuous time with the following conditions established:	≥ 2.5 sec.
Duty ratio of "ON"	$< 75\%$
Terminal output voltage	Low

Time Needed for Diagnosis: 2.5 seconds

Malfunction Indicator Light Illumination: Illuminates when malfunction occurs in 2 continuous driving cycles.

Normality Judgment

Judge as OK and clear the NG when the malfunction criteria below are met.

Judgment Value

Malfunction Criteria	Threshold Value
Terminal output voltage	High

6. DTC CLEAR CONDITION

- When the OK idling cycle is completed 40 times in a row
- When "Clear Memory" is performed

7. MALFUNCTION INDICATOR LIGHT CLEAR CONDITION

- When the OK driving cycle is completed 3 times in a row
- When "Clear Memory" is performed

8. FAIL SAFE

None

9. ECM OPERATION AT DTC SETTING

Memorize the freeze frame data. (For test mode \$02)

Diagnostic Trouble Code (DTC) Detecting Criteria

GENERAL DESCRIPTION

BO:DTC P0459 EVAPORATIVE EMISSION SYSTEM PURGE CONTROL VALVE CIRCUIT HIGH

1. OUTLINE OF DIAGNOSIS

Detect open or short circuit of the purge control solenoid valve.

Judge as NG when the ECM output level differs from the actual terminal level.

2. COMPONENT DESCRIPTION

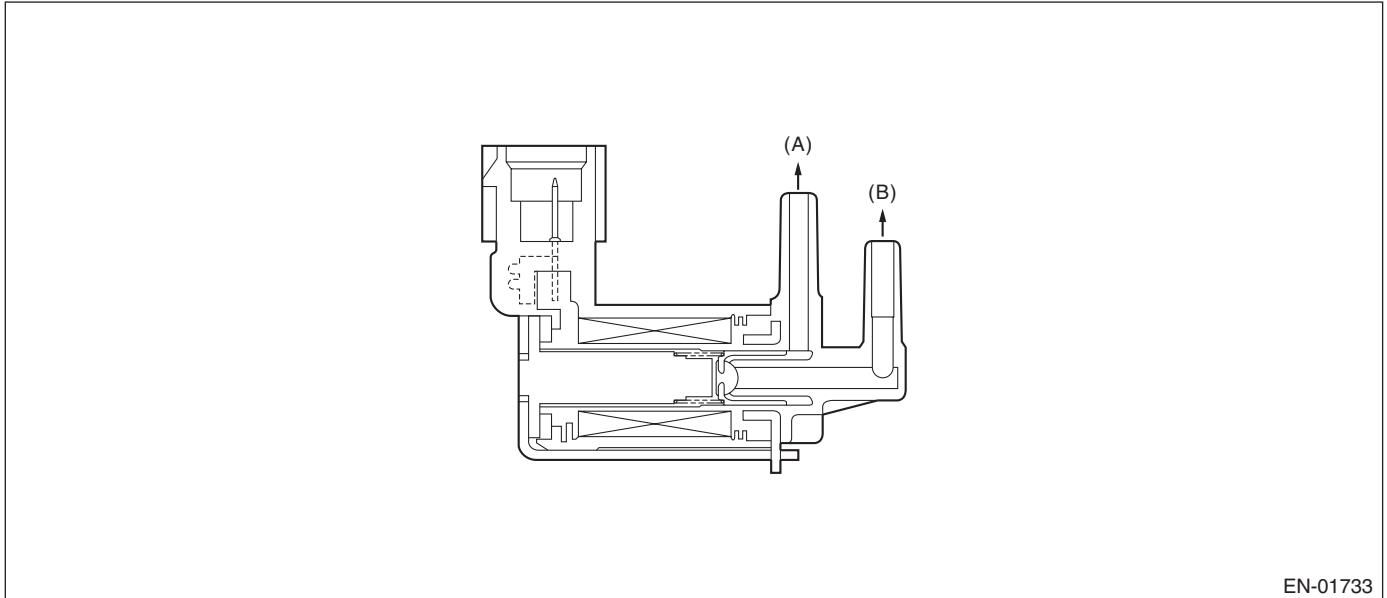

EN-01733

(A) To canister

(B) To intake manifold

3. ENABLE CONDITION

Secondary Parameters	Enable Conditions
Ignition switch	ON
Battery voltage	≥ 10.9 V
After engine starting	1 second or more

4. GENERAL DRIVING CYCLE

Always perform the diagnosis after starting the engine.

Diagnostic Trouble Code (DTC) Detecting Criteria

GENERAL DESCRIPTION

5. DIAGNOSTIC METHOD

Abnormality Judgment

Judge as NG when the malfunction criteria below are met.

Judgment Value

Malfunction Criteria	Threshold Value
Continuous time with the following conditions established:	≥ 2.5 sec.
Duty ratio of "ON"	≥ 25%
Terminal output voltage	High

Time Needed for Diagnosis: 2.5 seconds

Malfunction Indicator Light Illumination: Illuminates when malfunction occurs in 2 continuous driving cycles.

Normality Judgment

Judge as OK and clear the NG when the malfunction criteria below are met.

Judgment Value

Malfunction Criteria	Threshold Value
Terminal output voltage	Low

6. DTC CLEAR CONDITION

- When the OK idling cycle is completed 40 times in a row
- When "Clear Memory" is performed

7. MALFUNCTION INDICATOR LIGHT CLEAR CONDITION

- When the OK driving cycle is completed 3 times in a row
- When "Clear Memory" is performed

8. FAIL SAFE

None

9. ECM OPERATION AT DTC SETTING

Memorize the freeze frame data. (For test mode \$02)

Diagnostic Trouble Code (DTC) Detecting Criteria

GENERAL DESCRIPTION

BP:DTC P0461 FUEL LEVEL SENSOR "A" CIRCUIT RANGE/PERFORMANCE

1. OUTLINE OF DIAGNOSIS

Detect malfunctions of the fuel level sensor output property.

If the fuel level does not vary in a particular driving condition / engine condition where it should, judge as NG.

2. COMPONENT DESCRIPTION

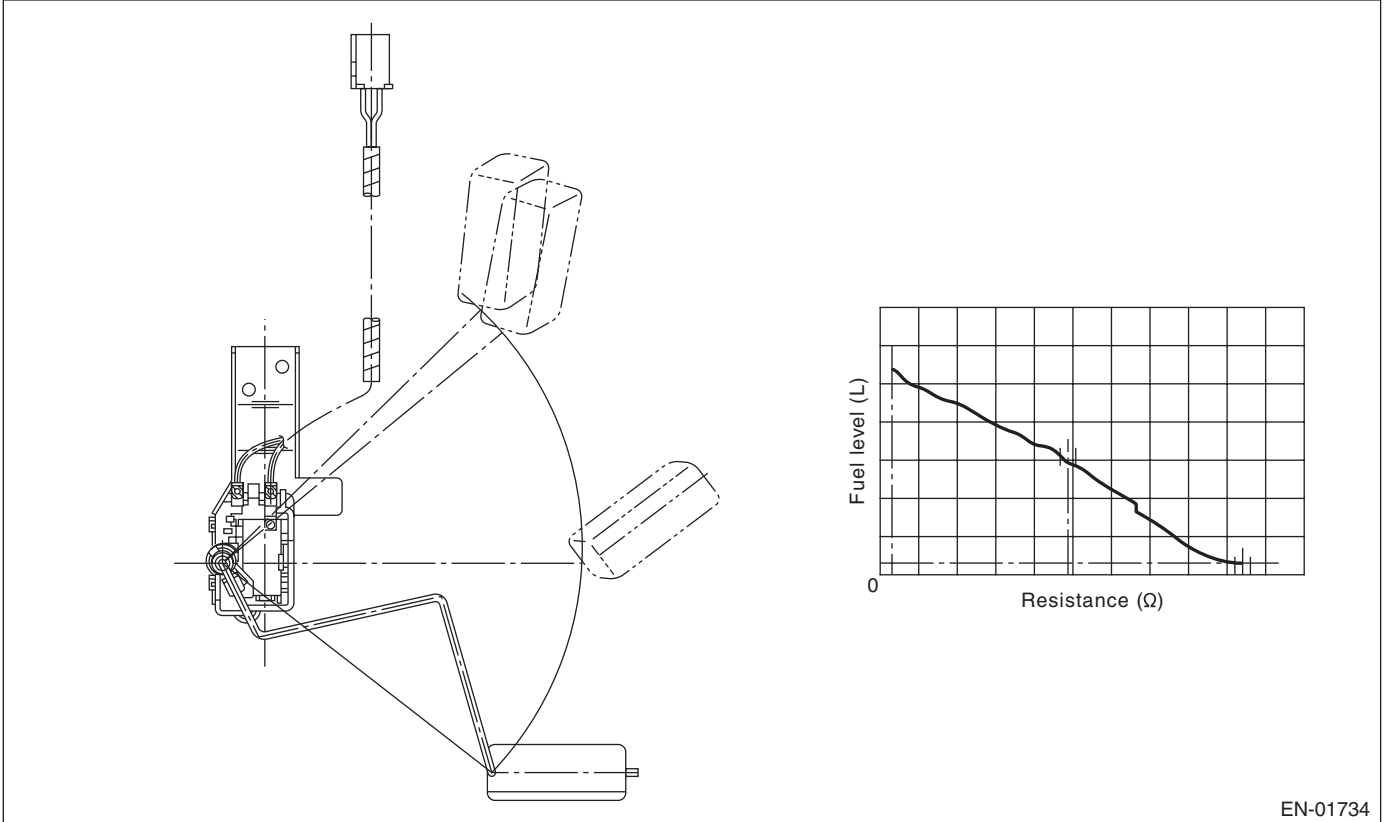

EN-01734

3. ENABLE CONDITION

Secondary Parameters	Enable Conditions
None	

4. GENERAL DRIVING CYCLE

Always perform the diagnosis continuously.

Diagnostic Trouble Code (DTC) Detecting Criteria

GENERAL DESCRIPTION

5. DIAGNOSTIC METHOD

Abnormality Judgment

Judge as NG when the malfunction criteria below are met.

Judgment Value

Malfunction Criteria	Threshold Value
Accumulated amount of intake air	> 331 kg (729.9 lb)
Max. – Min. values of fuel level output	< 2.6 ℓ (0.69 US gal, 0.57 Imp gal)
Battery voltage	≥ 10.9 V
After engine starting	5 seconds or more

Time Needed for Diagnosis: Undetermined

Malfunction Indicator Light Illumination: Illuminates when malfunction occurs in 2 continuous driving cycles.

Normality Judgment

Judge as OK and clear the NG when the malfunction criteria below are met.

Judgment Value

Malfunction Criteria	Threshold Value
Accumulated amount of intake air	> 331 kg (729.9 lb)
Max. – Min. values of fuel level output	≥ 2.6 ℓ (0.69 US gal, 0.57 Imp gal)
Battery voltage	≥ 10.9 V
After engine starting	5 seconds or more

6. DTC CLEAR CONDITION

- When the OK idling cycle is completed 40 times in a row
- When “Clear Memory” is performed

7. MALFUNCTION INDICATOR LIGHT CLEAR CONDITION

- When the OK driving cycle is completed 3 times in a row
- When “Clear Memory” is performed

8. FAIL SAFE

None

9. ECM OPERATION AT DTC SETTING

Memorize the freeze frame data. (For test mode \$02)

Diagnostic Trouble Code (DTC) Detecting Criteria

GENERAL DESCRIPTION

BQ:DTC P0462 FUEL LEVEL SENSOR “A” CIRCUIT LOW

1. OUTLINE OF DIAGNOSIS

Detect the open or short circuit of fuel level sensor. Judge as NG if it is out of specification.

2. COMPONENT DESCRIPTION

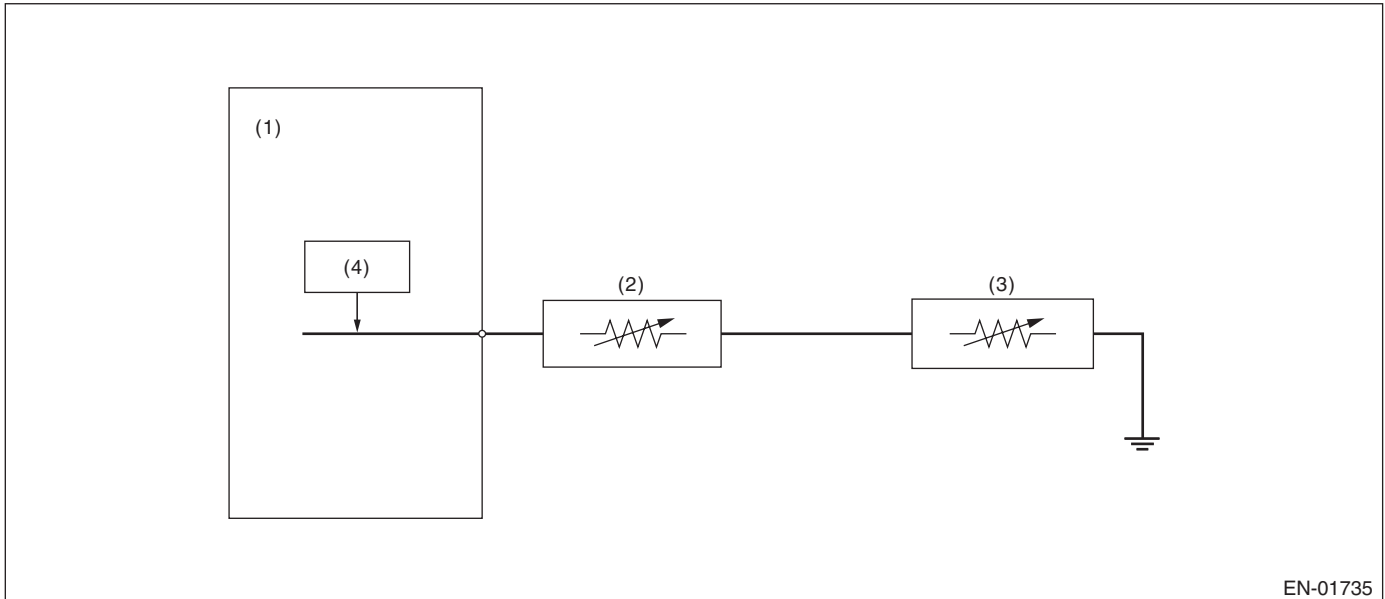

(1) Engine control module (ECM)

(3) Fuel sub level sensor

(4) Detecting circuit

(2) Fuel level sensor

3. ENABLE CONDITION

Secondary Parameters	Enable Conditions
None	

4. GENERAL DRIVING CYCLE

Always perform the diagnosis continuously.

Diagnostic Trouble Code (DTC) Detecting Criteria

GENERAL DESCRIPTION

5. DIAGNOSTIC METHOD

Abnormality Judgment

Judge as NG when the continuous time of meeting the malfunction criteria below becomes more than time needed for diagnosis (2.5 seconds).

Judgment Value

Malfunction Criteria	Threshold Value
Ignition switch	ON
Battery voltage	≥ 10.9 V
After engine starting	3 seconds or more
Output voltage	≤ 0.035 V

Time Needed for Diagnosis: 2.5 seconds

Malfunction Indicator Light Illumination: Illuminates when malfunction occurs in 2 continuous driving cycles.

Normality Judgment

Judge as OK and clear the NG when the malfunction criteria below are met.

Judgment Value

Malfunction Criteria	Threshold Value
Ignition switch	ON
Battery voltage	≥ 10.9 V
After engine starting	3 seconds or more
Output voltage	> 0.035 V

6. DTC CLEAR CONDITION

- When the OK idling cycle is completed 40 times in a row
- When "Clear Memory" is performed

7. MALFUNCTION INDICATOR LIGHT CLEAR CONDITION

- When the OK driving cycle is completed 3 times in a row
- When "Clear Memory" is performed

8. FAIL SAFE

None

9. ECM OPERATION AT DTC SETTING

Memorize the freeze frame data. (For test mode \$02)

Diagnostic Trouble Code (DTC) Detecting Criteria

GENERAL DESCRIPTION

BR:DTC P0463 FUEL LEVEL SENSOR "A" CIRCUIT HIGH

1. OUTLINE OF DIAGNOSIS

Detect the open or short circuit of fuel level sensor. Judge as NG if it is out of specification.

2. COMPONENT DESCRIPTION

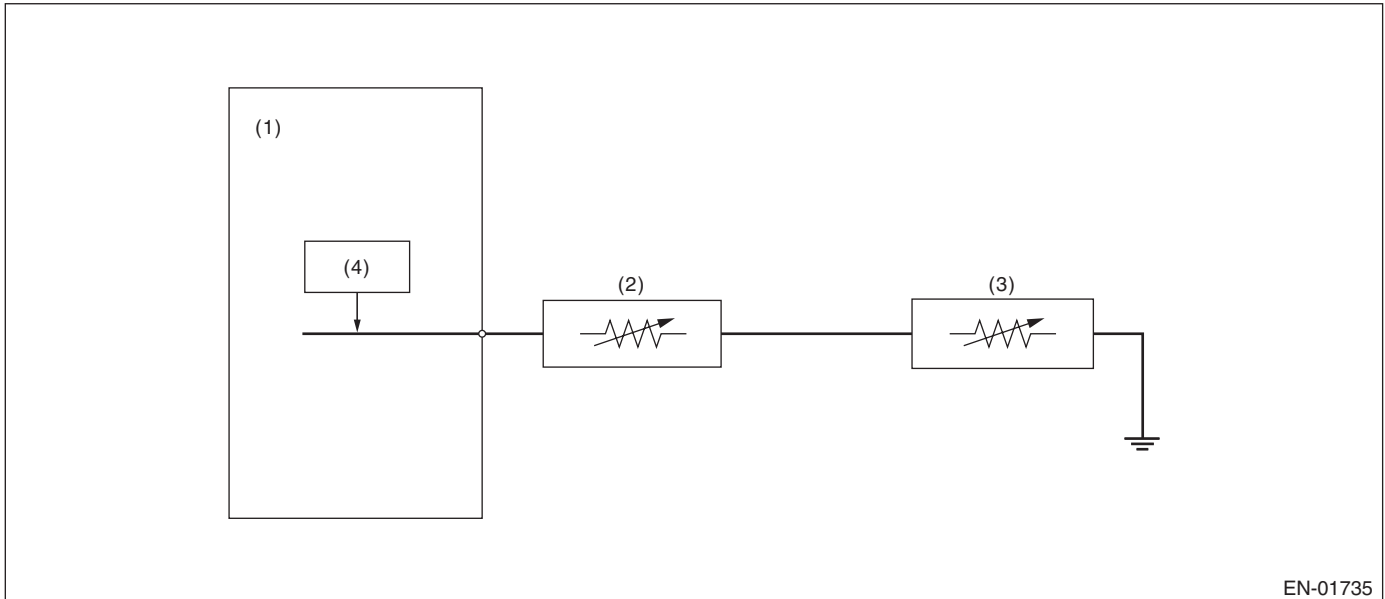

(1) Engine control module (ECM)

(3) Fuel sub level sensor

(4) Detecting circuit

(2) Fuel level sensor

3. ENABLE CONDITION

Secondary Parameters	Enable Condition
None	

4. GENERAL DRIVING CYCLE

Always perform the diagnosis continuously.

Diagnostic Trouble Code (DTC) Detecting Criteria

GENERAL DESCRIPTION

5. DIAGNOSTIC METHOD

Abnormality Judgment

Judge as NG when the continuous time of meeting the malfunction criteria below exceeds the time required for diagnosis (2.5 seconds).

Judgment Value

Malfunction Criteria	Threshold Value
Ignition switch	ON
Battery voltage	≥ 10.9 V
After engine starting	3 seconds or more
Output voltage	≥ 4.911 V

Time Needed for Diagnosis: 2.5 seconds

Malfunction Indicator Light Illumination: Illuminates when malfunction occurs in 2 continuous driving cycles.

Normality Judgment

Judge as OK and clear the NG when the malfunction criteria below are met.

Judgment Value

Malfunction Criteria	Threshold value
Ignition switch	ON
Battery voltage	≥ 10.9 V
After engine starting	3 seconds or more
Output voltage	< 4.911 V

6. DTC CLEAR CONDITION

- When the OK idling cycle is completed 40 times in a row
- When "Clear Memory" is performed

7. MALFUNCTION INDICATOR LIGHT CLEAR CONDITION

- When the OK driving cycle is completed 3 times in a row
- When "Clear Memory" is performed

8. FAIL SAFE

None

9. ECM OPERATION AT DTC SETTING

Memorize the freeze frame data. (For test mode \$02)

Diagnostic Trouble Code (DTC) Detecting Criteria

GENERAL DESCRIPTION

BS:DTC P0464 FUEL LEVEL SENSOR CIRCUIT INTERMITTENT

1. OUTLINE OF DIAGNOSIS

Detect the unstable output faults from the fuel level sensor caused by noise. Judge as NG when the max. value and cumulative value of output voltage variation of the fuel level sensor is larger than the threshold value.

2. ENABLE CONDITION

Malfunction Criteria	Threshold Value
Engine speed	≥ 500 rpm
After engine starting	1 second or more
Ignition switch	ON
Battery voltage	> 10.9 V
Idle switch	ON
Fuel level	9.0 — 51 ℓ (2.38 — 13.47 US gal, 1.98 — 11.22 Imp gal)
Vehicle speed = 0 km/h (0 MPH)	10 seconds or more

3. GENERAL DRIVING CYCLE

- Always perform the diagnosis continuously at idle speed.
- Pay attention to the fuel level.

Diagnostic Trouble Code (DTC) Detecting Criteria

GENERAL DESCRIPTION

4. DIAGNOSTIC METHOD

Calculate the Max. value (delflmax) and cumulative value (sumfl) of output voltage variation of fuel level sensor during 12.2 seconds. Judge as normal when both max. and cumulative values are not over the threshold value. Otherwise, when either of them is over the threshold value, the diagnosis counter counts up. Judge as NG if the counter indicated 4 counts.

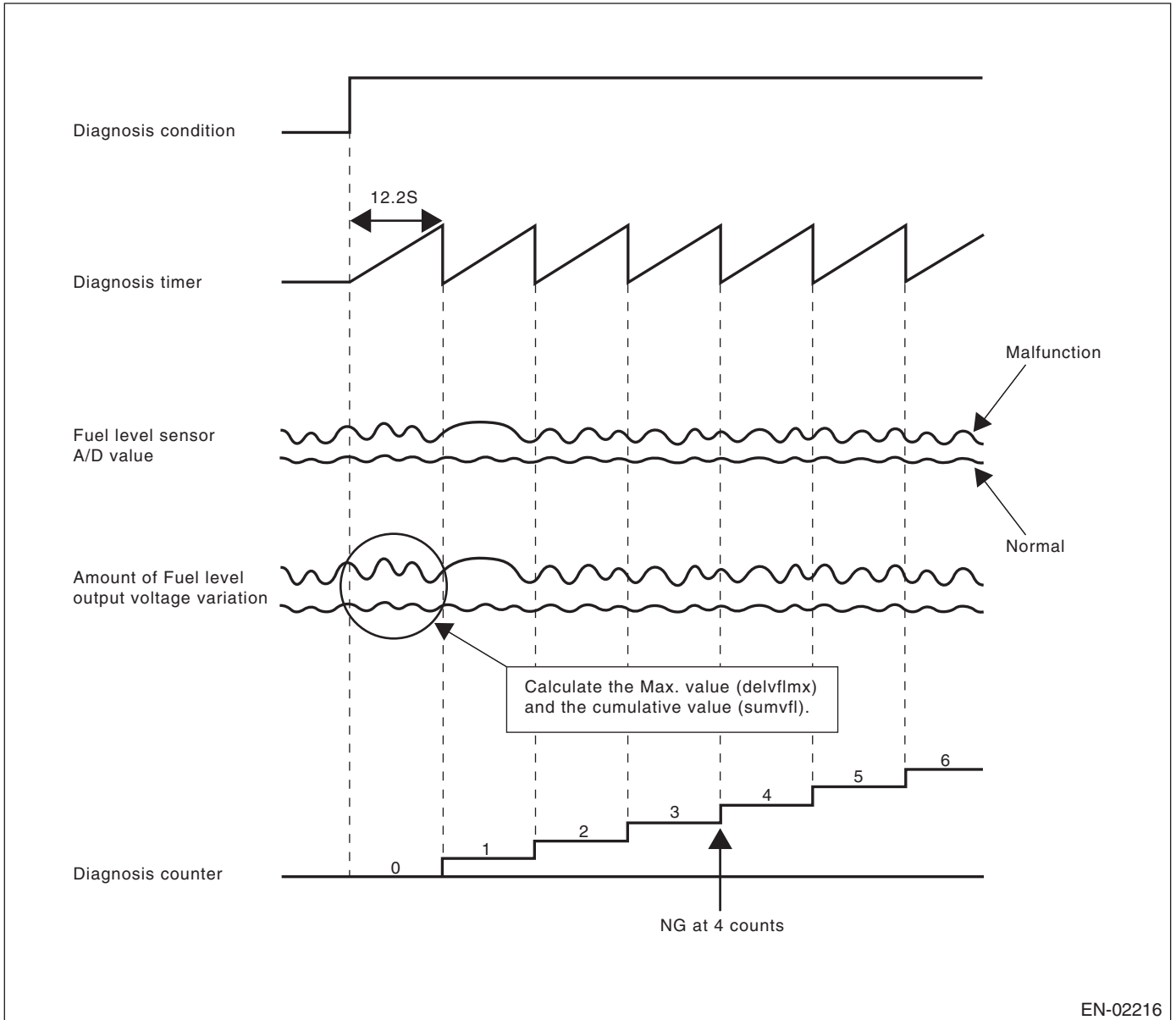

Diagnostic Trouble Code (DTC) Detecting Criteria

GENERAL DESCRIPTION

Abnormality Judgment

Judge as NG when the malfunction criteria below are met.

Judgment Value

Malfunction Criteria	Threshold Value
Total times of the condition reaching follows, DELFLMAX $\geq 0.2 - 0.26$ V or SUMFL ≥ 16 V At that time, DELFLMAX: Maximum difference of sensor output for 12.2 seconds; SUMFL: Integrated value of the sensor output deviation for 12.2 seconds	≥ 4 times

The diagnosis counter does not count up when the following conditions are completed within 12.2 seconds.

Maximum value – minimum value of change of tank pressure for 12.2 seconds	≥ 0.05 kPa (0.375 mmHg, 0.02 inHg)
Maximum value – minimum value of battery voltage for 12.2 seconds	≥ 1.65 V

Time Needed for Diagnosis: 12.2 seconds \times 4 times

Malfunction Indicator Light Illumination: Illuminates when malfunction occurs in 2 continuous driving cycles.

Normality Judgment

Judge as OK and clear the NG when the malfunction criteria below are met.

Judgment Value

Malfunction Criteria	Threshold Value
DELFLMAX SUMFL At that time, DELFLMAX: Maximum difference of sensor output for 12.2 seconds; SUMFL: Integrated value of the sensor output deviation for 12.2 seconds	$< 0.2 - 0.26$ V < 16 V

5. DTC CLEAR CONDITION

- When the OK idling cycle is completed 40 times in a row
- When "Clear Memory" is performed

6. MALFUNCTION INDICATOR LIGHT CLEAR CONDITION

- When the OK driving cycle is completed 3 times in a row
- When "Clear Memory" is performed

7. FAIL SAFE

None

8. ECM OPERATION AT DTC SETTING

Memorize the freeze frame data. (For test mode \$02)

Diagnostic Trouble Code (DTC) Detecting Criteria

GENERAL DESCRIPTION

BT:DTC P0483 FAN RATIONALITY CHECK

1. OUTLINE OF DIAGNOSIS

Detect the function abnormality of the radiator fan.

Judge as NG when the engine coolant temperature slowly decreases even when the radiator fan is rotating.

2. ENABLE CONDITION

Diagnostic enable condition is established if the radiator fan changes from OFF → ON when all of the conditions below are met.

When one of the conditions below is not met, the diagnostic enable condition is not established.

Secondary Parameters	Enable Conditions
Engine speed	560 — 900 rpm
Idle switch	ON
Vehicle speed	< 2 km/h (1 MPH)
Battery voltage	≥ 10.9 V

3. GENERAL DRIVING CYCLE

Perform the diagnosis continuously when the radiator fan changes from OFF → ON when idling.

4. DIAGNOSTIC METHOD

Abnormality Judgment

Judge as NG when the continuous time of meeting the malfunction criteria below becomes more than 5 minutes.

Judgment Value

Malfunction Criteria	Threshold Value
Engine coolant temperature	≥ 100°C (212°F)
Radiator fan signal change	OFF to ON
Engine coolant temperature	Does not decrease

Time Needed for Diagnosis: 5 minutes

Malfunction Indicator Light Illumination: Illuminates when malfunction occurs in 2 continuous driving cycles.

Normality Judgment

Judge as OK and clear the NG when the malfunction criteria below are met.

Judgment Value

Malfunction Criteria	Threshold Value
Radiator fan signal change	OFF to ON
Engine coolant temperature	Decrease

5. DTC CLEAR CONDITION

- When the OK idling cycle is completed 40 times in a row
- When "Clear Memory" is performed

6. MALFUNCTION INDICATOR LIGHT CLEAR CONDITION

- When the OK driving cycle is completed 3 times in a row
- When "Clear Memory" is performed

7. FAIL SAFE

None

8. ECM OPERATION AT DTC SETTING

Memorize the freeze frame data. (For test mode \$02)

Diagnostic Trouble Code (DTC) Detecting Criteria

GENERAL DESCRIPTION

BU:DTC P0502 VEHICLE SPEED SENSOR “A” CIRCUIT LOW INPUT

1. OUTLINE OF DIAGNOSIS

Detect the open or short circuit of vehicle speed. Judge NG when low vehicle speed (0 km/h (0 MPH)) remains whereas it seemed to be in a usual driving speed.

2. ENABLE CONDITION (FOR ABNORMALITY JUDGMENT ONLY)

Secondary Parameters	Enable Condition
Engine speed	< 4000 rpm
Fuel cut in decel.	In operation
Battery voltage	≥ 10.9 V

3. GENERAL DRIVING CYCLE

Perform the diagnosis continuously during deceleration fuel cut.

4. DIAGNOSTIC METHOD

Abnormality Judgment

Judge as NG when the continuous time of meeting the malfunction criteria below becomes 4 seconds or more.

Judgment Value

Malfunction Criteria	Threshold Value
Vehicle speed	< 1

Time Needed for Diagnosis: 4 seconds

Malfunction Indicator Light Illumination: Illuminates as soon as a malfunction occurs.

Normality Judgment

Judge as OK and clear the NG when all of the following criteria are established.

Malfunction Criteria	Threshold Value
Vehicle speed	≥ 1
Starter switch	OFF
Starter switch ON → OFF time	≥ 3 sec.

5. DTC CLEAR CONDITION

- When the OK idling cycle is completed 40 times in a row
- When “Clear Memory” is performed

6. MALFUNCTION INDICATOR LIGHT CLEAR CONDITION

- When the OK driving cycle is completed 3 times in a row
- When “Clear Memory” is performed

7. FAIL SAFE

- Vehicle speed sensor signal process: Vehicle speed = 10 km/h (6 MPH)
- ISC control: Open loop compensation is set to specified value (1 g (0.04 oz)/s). Not allowed to calculate ISC feed back amount.
- Radiator fan control: Both main and sub fan ON
- Tumble generator valve control: Open the tumble generator valve.

8. ECM OPERATION AT DTC SETTING

Memorize the freeze frame data. (For test mode \$02)

Diagnostic Trouble Code (DTC) Detecting Criteria

GENERAL DESCRIPTION

BV:DTC P0503 VEHICLE SPEED SENSOR “A” INTERMITTENT/ERRATIC/HIGH

1. OUTLINE OF DIAGNOSIS

Detect the open or short circuit of vehicle speed. Judge NG when high vehicle speed (240 km/h (149 MPH) or more) remains whereas it seemed to be in a usual driving speed.

2. ENABLE CONDITION (FOR ABNORMALITY JUDGMENT ONLY)

Secondary Parameters	Enable Condition
Engine speed	< 4000 rpm
Fuel cut in decel.	In operation
Battery voltage	≥ 10.9 V

3. GENERAL DRIVING CYCLE

Perform the diagnosis continuously during deceleration fuel cut.

4. DIAGNOSTIC METHOD

Abnormality Judgment

Judge as NG when the continuous time of meeting the malfunction criteria below becomes 4 seconds or more.

Judgment Value

Malfunction Criteria	Threshold Value
Vehicle speed	≥ 240

Time Needed for Diagnosis: 4 seconds

Malfunction Indicator Light Illumination: Illuminates as soon as a malfunction occurs.

Normality Judgment

Judge as OK and clear the NG when all of the following criteria are established.

Malfunction Criteria	Threshold Value
Vehicle speed	< 240
Starter switch	OFF
Starter switch ON → OFF time	≥ 3 sec.

5. DTC CLEAR CONDITION

- When the OK idling cycle is completed 40 times in a row
- When “Clear Memory” is performed

6. MALFUNCTION INDICATOR LIGHT CLEAR CONDITION

- When the OK driving cycle is completed 3 times in a row
- When “Clear Memory” is performed

7. FAIL SAFE

- Vehicle speed sensor signal process: Vehicle speed = 10 km/h (6 MPH)
- ISC control: Open loop compensation is set to specified value (1 g (0.04 oz)/s). Not allowed to calculate ISC feed back amount.
- Radiator fan control: Both main and sub fan ON
- Tumble generator valve control: Open the tumble generator valve.

8. ECM OPERATION AT DTC SETTING

Memorize the freeze frame data. (For test mode \$02)

Diagnostic Trouble Code (DTC) Detecting Criteria

GENERAL DESCRIPTION

BW:DTC P0506 IDLE AIR CONTROL SYSTEM RPM LOWER THAN EXPECTED

1. OUTLINE OF DIAGNOSIS

Detect the malfunction that actual engine speed is not close to target engine speed during idling. Judge as NG when actual engine speed is not close to target engine speed during idling.

2. ENABLE CONDITION

Secondary Parameters	Enable Conditions
Engine coolant temperature	≥ 75°C (167°F)
Battery voltage	≥ 10.9 V
Atmospheric pressure	> 75.1 kPa (563 mmHg, 22.2 inHg)
Fuel level	≥ 9.0 ℓ (2.38 US gal, 1.98 Imp gal)
After engine starting	≥ 10.5 sec.
Feedback in ISC	In operation
Lambda value	0.81 — 1.1
After air condition switching ON/OFF	> 5.1 sec.
After intake manifold pressure changes more than 4 kPa (30 mmHg, 1.2 inHg)	> 5.1 sec.
After neutral switch ON/OFF change	> 5.1 sec.
Vehicle speed	0 km/h (0 MPH)

3. GENERAL DRIVING CYCLE

Perform the diagnosis continuously at idling after warming up engine.

4. DIAGNOSTIC METHOD

Abnormality Judgment

Judge as NG when the continuous time of meeting the malfunction criteria below is 10 seconds × 3 times.

Judgment Value

Malfunction Criteria	Threshold Value
Actual – target engine speed	< –100 rpm
Feedback value for ISC	Max.

Time Needed for Diagnosis: 10 seconds × 3 times

Malfunction Indicator Light Illumination: Illuminates when malfunction occurs in 2 continuous driving cycles.

Normality Judgment

Judge as OK and clear NG when the continuous time of meeting the malfunction criteria below becomes more than 10 seconds.

Judgment Value

Malfunction Criteria	Threshold Value
Actual – target engine speed	≥ –100 rpm

5. DTC CLEAR CONDITION

- When the OK idling cycle is completed 40 times in a row
- When “Clear Memory” is performed

6. MALFUNCTION INDICATOR LIGHT CLEAR CONDITION

- When the OK driving cycle is completed 3 times in a row
- When “Clear Memory” is performed

Diagnostic Trouble Code (DTC) Detecting Criteria

GENERAL DESCRIPTION

7. FAIL SAFE

None

8. ECM OPERATION AT DTC SETTING

Memorize the freeze frame data. (For test mode \$02)

Diagnostic Trouble Code (DTC) Detecting Criteria

GENERAL DESCRIPTION

BX:DTC P0507 IDLE AIR CONTROL SYSTEM RPM HIGHER THAN EXPECTED

1. OUTLINE OF DIAGNOSIS

Detect the malfunction that actual engine speed is not close to target engine speed during idling. Judge as NG when actual engine speed is not close to target engine speed during idling.

2. ENABLE CONDITION

Secondary Parameters	Enable Conditions
Engine coolant temperature	≥ 75°C (167°F)
Battery voltage	≥ 10.9 V
Atmospheric pressure	> 75.1 kPa (563 mmHg, 22.2 inHg)
Fuel level	≥ 9.0 ℓ (2.38 US gal, 1.98 Imp gal)
After engine starting	≥ 10.5 sec.
Feedback in ISC	In operation
Lambda value	0.81 — 1.1
After air condition switching ON/OFF	> 5.1 sec.
After intake manifold pressure changes more than 4 kPa (30 mmHg, 1.2 inHg)	> 5.1 sec.
After neutral switch ON/OFF change	> 5.1 sec.
Vehicle speed	0 km/h (0 MPH)

3. GENERAL DRIVING CYCLE

Perform the diagnosis continuously at idling after warming up engine.

4. DIAGNOSTIC METHOD

Abnormality Judgment

Judge as NG when the continuous time of meeting the malfunction criteria below is 10 seconds × 3 times.

Judgment Value

Malfunction Criteria	Threshold Value
Actual – target engine speed	≥ 200 rpm
Feedback value for ISC	Min.

Time Needed for Diagnosis: 10 seconds × 3 times

Malfunction Indicator Light Illumination: Illuminates when malfunction occurs in 2 continuous driving cycles.

Normality Judgment

Judge as OK and clear NG when the continuous time of meeting the malfunction criteria below becomes more than 10 seconds.

Judgment Value

Malfunction Criteria	Threshold Value
Actual – target engine speed	< 200 rpm

5. DTC CLEAR CONDITION

- When the OK idling cycle is completed 40 times in a row
- When “Clear Memory” is performed

6. MALFUNCTION INDICATOR LIGHT CLEAR CONDITION

- When the OK driving cycle is completed 3 times in a row
- When “Clear Memory” is performed

Diagnostic Trouble Code (DTC) Detecting Criteria

GENERAL DESCRIPTION

7. FAIL SAFE

None

8. ECM OPERATION AT DTC SETTING

Memorize the freeze frame data. (For test mode \$02)

Diagnostic Trouble Code (DTC) Detecting Criteria

GENERAL DESCRIPTION

BY:DTC P0512 STARTER REQUEST CIRCUIT

1. OUTLINE OF DIAGNOSIS

Detect the open or short circuit of starter SW.
Judge ON NG when the starter SW signal remains ON.

2. ENABLE CONDITION

Secondary Parameters	Enable Conditions
None	

3. GENERAL DRIVING CYCLE

Always perform the diagnosis continuously.

4. DIAGNOSTIC METHOD

Abnormality Judgment

Judge as ON NG when the continuous time of meeting the malfunction criteria below becomes more than 3 minutes.

Judgment Value

Malfunction Criteria	Threshold Value
Engine speed	> 500 rpm
Starter OFF signal	Not detected
Battery voltage	> 8 V

Time Needed for Diagnosis: 180 seconds

Malfunction Indicator Light Illumination: Illuminates when malfunction occurs in 2 continuous driving cycles.

Normality Judgment

Judge ON OK and clear the NG when the malfunction criteria below are met.

Judgment Value

Malfunction Criteria	Threshold Value
Starter OFF signal	Detected
Battery voltage	> 8 V

5. DTC CLEAR CONDITION

- When the OK idling cycle is completed 40 times in a row
- When "Clear Memory" is performed

6. MALFUNCTION INDICATOR LIGHT CLEAR CONDITION

- When the OK driving cycle is completed 3 times in a row
- When "Clear Memory" is performed

7. FAIL SAFE

None

8. ECM OPERATION AT DTC SETTING

Memorize the freeze frame data. (For test mode \$02)

BZ:DTC P0519 IDLE AIR CONTROL SYSTEM PERFORMANCE

1. OUTLINE OF DIAGNOSIS

Detect malfunctions in which the engine speed continues to rise during idling.

2. ENABLE CONDITION

Secondary Parameters	Enable Conditions
Battery voltage	≥ 10.9 V
Feedback in ISC	In operation
Vehicle speed	< 4 km/h (2 MPH)
After engine starting	1 second or more

3. GENERAL DRIVING CYCLE

Perform the diagnosis continuously if the vehicle speed at less than 4 km/h (2 MPH).

4. DIAGNOSTIC METHOD

Judge as NG when the continuous time of meeting the all malfunction criteria below becomes more than 2 seconds.

Judgment Value

Malfunction Criteria	Threshold Value
Engine speed – targeted engine speed	> 2000 rpm
Feedback compensation for ISC	≤ 0
Engine speed change every 180 degree engine revs.	≥ -5 rpm

Time Needed for Diagnosis: 2 seconds

Malfunction Indicator Light Illumination: Illuminates as soon as a malfunction occurs.

Normality Judgment

Judge as OK and clear NG when the continuous time of meeting the malfunction criteria below becomes more than 5 seconds.

Judgment Value

Malfunction Criteria	Threshold Value
Engine speed – targeted engine speed	< 200 rpm

5. DTC CLEAR CONDITION

- When the OK idling cycle is completed 40 times in a row
- When “Clear Memory” is performed

6. MALFUNCTION INDICATOR LIGHT CLEAR CONDITION

- When the OK driving cycle is completed 3 times in a row
- When “Clear Memory” is performed

7. FAIL SAFE

Fuel cut: Cuts off fuel for only #1 and #2 cylinders, or for all cylinders according to vehicle speed, engine speed, and throttle position.

8. ECM OPERATION AT DTC SETTING

Memorize the freeze frame data. (For test mode \$02)

Diagnostic Trouble Code (DTC) Detecting Criteria

GENERAL DESCRIPTION

CA:DTC P0600 SERIAL COMMUNICATION LINK

1. OUTLINE OF DIAGNOSIS

Detect malfunction of CAN communication.

Judge as NG when CAN communication is not established, CAN communication with AT is not established, and the data from the AT is not normal.

2. COMPONENT DESCRIPTION

ECM and TCM are connected by high speed CAN.

(Common Specifications)

CAN Protocol 2.0 B (Active)

Frame Format: 11 Bit ID Frame (Standard Frame)

(High speed CAN)

Conforms to ISO11898

Communication Speed: 500 kbps

3. ENABLE CONDITION

Secondary Parameters	Enable Conditions
Battery voltage	≥ 10.9 V
Starter switch	OFF
Engine	run

4. GENERAL DRIVING CYCLE

Perform the diagnosis continuously after starting the engine.

5. DIAGNOSTIC METHOD

Abnormality Judgment

Judge as NG when either of the following conditions is established.

Judge as OK and clear the NG when the continuous time when all of the following criteria are established is more than the predetermined time (1 second).

Judgment Value

Malfunction Criteria	Threshold Value
bus off flag or warning flag	set
ID is not received from the TCM	= 500 milliseconds

Time Needed for Diagnosis: 1 time

Malfunction Indicator Light Illumination: Illuminates as soon as a malfunction occurs.

6. DTC CLEAR CONDITION

- When the OK idling cycle is completed 40 times in a row
- When "Clear Memory" is performed

7. MALFUNCTION INDICATOR CLEAR PARAMETERS

- When the OK driving cycle is completed 3 times in a row
- When "Clear Memory" is performed

8. FAIL SAFE

None

9. ECM OPERATION AT DTC SETTING

Memorize the freeze frame data. (For test mode \$02)

Diagnostic Trouble Code (DTC) Detecting Criteria

GENERAL DESCRIPTION

CB:DTC P0604 INTERNAL CONTROL MODULE RANDOM ACCESS MEMORY (RAM) ERROR

1. OUTLINE OF DIAGNOSIS

Detect the malfunction of microcomputer (RAM).

When there is a problem in the main CPU normal RAM, or the sub CPU normal RAM, judge as NG. Judge as OK when both are operating properly.

If it is possible to write data to the whole area of RAM in the initial routine, and is possible to read the same data, it is judged as OK, and if not, NG.

2. ENABLE CONDITION

Secondary Parameters	Enable Conditions
None	

Diagnosis with the initial routine.

3. GENERAL DRIVING CYCLE

Perform the diagnosis as soon as the ignition switch is turned to ON.

4. DIAGNOSTIC METHOD

Abnormality Judgment

Judge as NG when the malfunction criteria below are met.

Judgment Value

Malfunction Criteria	Threshold Value
Main CPU normal RAM abnormal Write 5AA5A55A and then read. (Whole area of RAM) Or write A55A5AA5 and then read. (Whole area of RAM)	5AA5A55A cannot be read. A55A5AA5 cannot be read.
Sub CPU normal RAM abnormal Write 5AA5 and then read. (Whole area of RAM) Or write A55A and then read. (Whole area of RAM)	5AA5 cannot be read. A55A cannot be read.

Time Needed for Diagnosis: Undetermined

Malfunction Indicator Light Illumination: Illuminates as soon as a malfunction occurs.

Normality Judgment

Judge as OK and clear the NG when the malfunction criteria below are met.

Judgment Value

Malfunction Criteria	Threshold Value
Main CPU normal RAM abnormal Write 5AA5A55A and then read. (Whole area of RAM) And write A55A5AA5 and then read. (Whole area of RAM)	5AA5A55A can be read. A55A5AA5 can be read.
Sub CPU normal RAM abnormal Write 5AA5 and then read. (Whole area of RAM) And write A55A and then read. (Whole area of RAM)	5AA5 can be read. A55A can be read.

Diagnostic Trouble Code (DTC) Detecting Criteria

GENERAL DESCRIPTION

5. DTC CLEAR CONDITION

- When the OK idling cycle is completed 40 times in a row
- When "Clear Memory" is performed

6. MALFUNCTION INDICATOR LIGHT CLEAR CONDITION

- When the OK driving cycle is completed 3 times in a row
- When "Clear Memory" is performed

7. FAIL SAFE

None

8. ECM OPERATION AT DTC SETTING

Memorize the freeze frame data. (For test mode \$02)

Diagnostic Trouble Code (DTC) Detecting Criteria

GENERAL DESCRIPTION

CC:DTC P0605 INTERNAL CONTROL MODULE READ ONLY MEMORY (ROM) ERROR

1. OUTLINE OF DIAGNOSIS

Judge as NG when SUM value of ROM is outside the standard value.

2. ENABLE CONDITION

Secondary Parameters	Enable Conditions
Ignition switch	ON

3. GENERAL DRIVING CYCLE

Always perform the diagnosis continuously.

4. DIAGNOSTIC METHOD

Abnormality Judgment

Judge as NG when the continuous time of meeting the malfunction criteria below becomes 0.5 seconds or more.

Judgment Value

Malfunction Criteria	Threshold Value
SUM value of ROM	Specification

Time Needed for Diagnosis: Undetermined

Malfunction Indicator Light Illumination: Illuminates as soon as a malfunction occurs.

5. DTC CLEAR CONDITION

- When the OK idling cycle is completed 40 times in a row
- When "Clear Memory" is performed (Only with engine stopped)

6. MALFUNCTION INDICATOR LIGHT CLEAR CONDITION

- When the OK driving cycle is completed 3 times in a row
- When "Clear Memory" is performed (Only with engine stopped)

7. FAIL SAFE

Stop the continuity to the electronic throttle control motor. (Throttle opening is fixed to 6°.)

8. ECM OPERATION AT DTC SETTING

Memorize the freeze frame data. (For test mode \$02)

Diagnostic Trouble Code (DTC) Detecting Criteria

GENERAL DESCRIPTION

CD:DTC P0607 CONTROL MODULE PERFORMANCE

1. OUTLINE OF DIAGNOSIS

Judge as NG when either the following is completed.

- When the read value of throttle position sensor 1 signal is mismatched between main CPU and sub CPU.
- When the read value of accelerator pedal position sensor 1 signal is mismatched between main CPU and sub CPU.
- When the sub CPU operates abnormally.
- When the communication between main CPU \leftrightarrow sub CPU is abnormal.
- When the input amplifier circuit of throttle position sensor 1 is abnormal.
- When the cruise control cannot be canceled correctly.
- When the signal of brake SW1 and 2 is mismatched.
- When the directed angle from the main CPU is abnormal.

2. COMPONENT DESCRIPTION

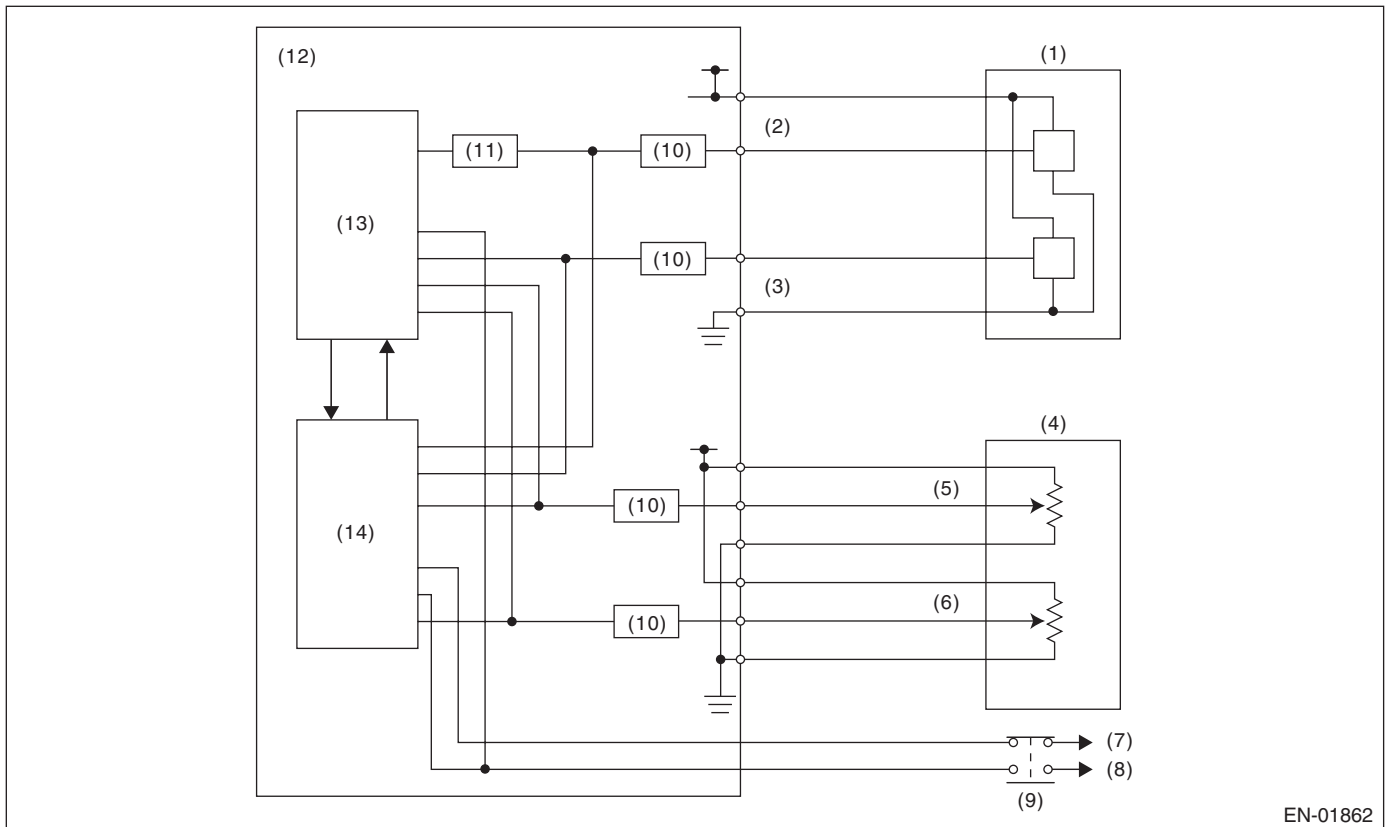

EN-01862

- | | | |
|---|---|----------------------------------|
| (1) Throttle position sensor | (6) Accelerator pedal position sensor 2 | (10) I/F circuit |
| (2) Throttle position sensor 1 | (7) Battery | (11) Amplifier circuit |
| (3) Throttle position sensor 2 | (8) Stop light | (12) Engine control module (ECM) |
| (4) Accelerator pedal position sensor | (9) Brake switch | (13) Sub CPU |
| (5) Accelerator pedal position sensor 1 | | (14) Main CPU |

Diagnostic Trouble Code (DTC) Detecting Criteria

GENERAL DESCRIPTION

3. ENABLE CONDITION

Secondary Parameters	Enable Conditions
(1) Ignition switch	ON
(2) Ignition switch	ON
(3) None	—
(4) None	—
(5) Throttle opening angle	
(6) Brake switch (only with cruise control)	ON
(7) None	—
(8) Cruise control	OFF

4. GENERAL DRIVING CYCLE

- (1) — (4): Always perform the diagnosis continuously.
- (5): Always perform the diagnosis continuously when idling.
- (6): Perform the diagnosis when the brake pedal is depressed.
- (7): Always perform the diagnosis continuously.
- (8): Always perform the diagnosis continuously when the cruise control pedal is not operating.

5. DIAGNOSTIC METHOD

Judge as OK and clear the NG when the malfunction criteria below are met.

Judgment Value

Malfunction Criteria	Threshold Value
(1) Difference of CPU reading value of the throttle position sensor signal	0.0858 V
(2) Difference of CPU on read value of the accelerator pedal position sensor signal	0.038 V
(3) WD pulse from sub CPU	WD pulse occur
(4) Communication between CPU	Possible to communicate
(5) Throttle position sensor 1 opening angle — (Throttle position sensor 1 opening angle after the amplifier) 1/4	< 3°
(6) Cruise control cancel signal at brake ON	Cruise control cancel signal ON
(7) Brake switch 1, 2 signal	SW 1 and 2 are matched

Time Needed for Diagnosis:

- 1. 250 milliseconds
- 2. 250 milliseconds
- 3. 200 milliseconds
- 4. 200 milliseconds
- 5. 24 milliseconds
- 6. 250 milliseconds
- 7. 200 milliseconds

Malfunction Indicator Light Illumination: Illuminates as soon as a malfunction occurs.

6. DTC CLEAR CONDITION

- When the OK idling cycle is completed 40 times in a row
- When “Clear Memory” is performed

7. MALFUNCTION INDICATOR LIGHT CLEAR CONDITION

- When the OK driving cycle is completed 3 times in a row
- When “Clear Memory” is performed

8. FAIL SAFE

Stop the continuity to the electronic throttle control motor. (Throttle opening is fixed to 6°.)

9. ECM OPERATION AT DTC SETTING

Memorize the freeze frame data. (For test mode \$02)

Diagnostic Trouble Code (DTC) Detecting Criteria

GENERAL DESCRIPTION

CE:DTC P0638 THROTTLE ACTUATOR CONTROL RANGE/PERFORMANCE (BANK 1)

1. OUTLINE OF DIAGNOSIS

Judge as NG when the target opening angle and actual opening angle is mismatched or the current to motor is more than specified duty for specified time continuously.

2. COMPONENT DESCRIPTION

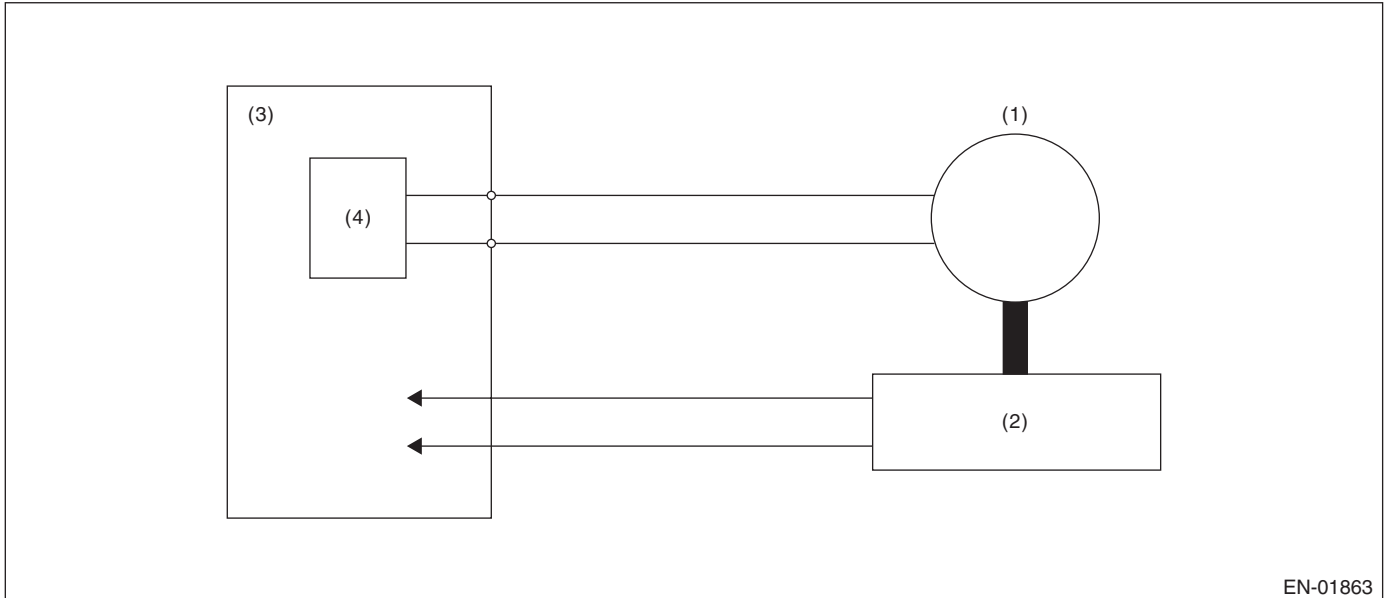

- (1) Motor
(2) Throttle position sensor
(3) Engine control module (ECM)
(4) Drive circuit

3. ENABLE CONDITION

Secondary Parameters	Enable Conditions
Ignition switch	ON
Normal operation of electric throttle control	ON

4. GENERAL DRIVING CYCLE

Always perform the diagnosis continuously when the electric throttle control is operating.

Diagnostic Trouble Code (DTC) Detecting Criteria

GENERAL DESCRIPTION

5. DIAGNOSTIC METHOD

Judge as OK and clear the NG when the malfunction criteria below are met.

Judgment Value

Malfunction Criteria	Threshold Value
Difference between target opening angle and actual opening angle	3.5° or less
Output duty to drive circuit	95% or less

Time Needed for Diagnosis:

- Target opening angle and actual opening angle: 250 milliseconds (For NG) 2000 milliseconds (For OK)
- Output duty to drive circuit: 2000 milliseconds

Details of Judgment Value

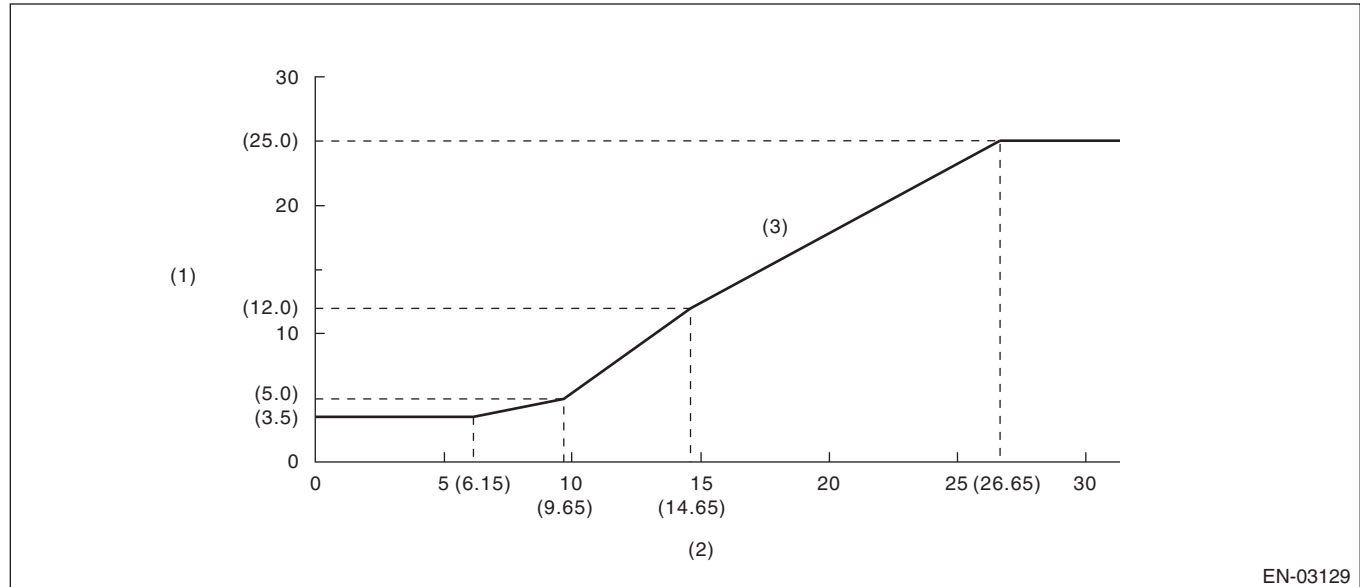

- (1) Difference between target opening angle and actual opening angle (°) (2) Target throttle opening angle (°) (3) NG area

Diagnostic Trouble Code (DTC) Detecting Criteria

GENERAL DESCRIPTION

Details of Judgment (The actual opening angle \leq target opening angle is always 1000 milliseconds)

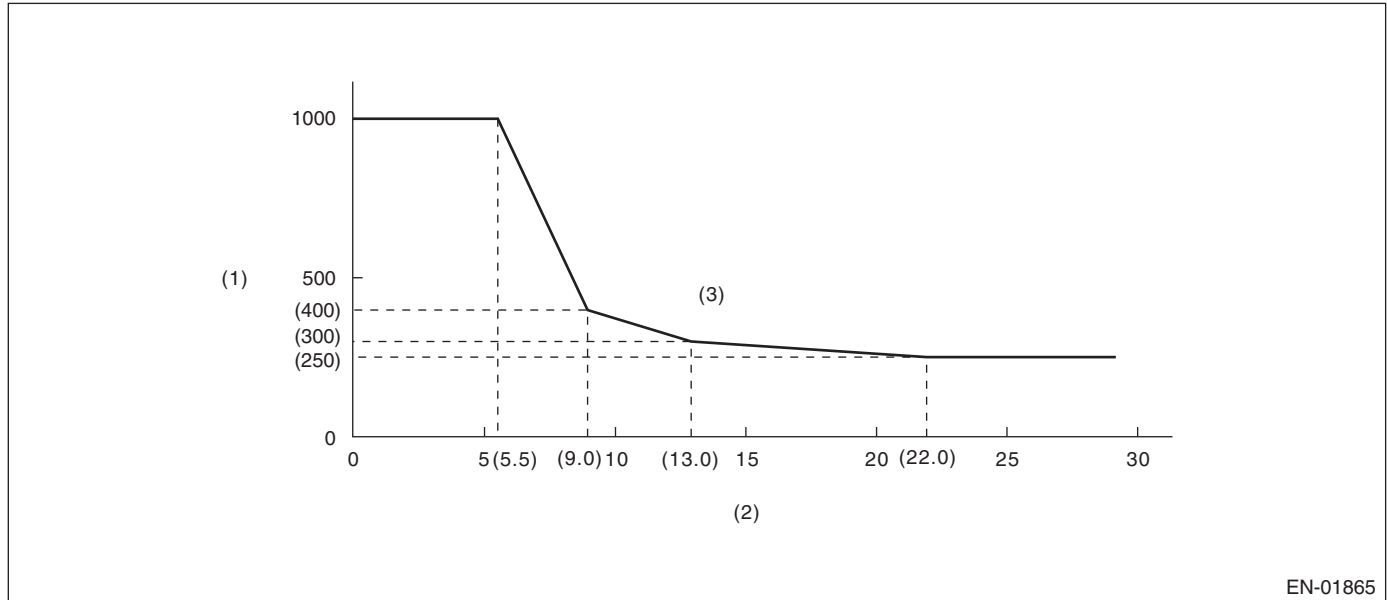

EN-01865

(1) Judgment time (milliseconds)

(2) Throttle position sensor 1 opening angle

(3) NG area

Malfunction Indicator Light Illumination: Illuminates as soon as a malfunction occurs.

6. DTC CLEAR CONDITION

- When the OK idling cycle is completed 40 times in a row
- When "Clear Memory" is performed (Only with engine stopped)

7. MALFUNCTION INDICATOR LIGHT CLEAR CONDITION

- When the OK driving cycle is completed 3 times in a row
- When "Clear Memory" is performed (Only with engine stopped)

8. FAIL SAFE

Stop the continuity to the electronic throttle control motor. (Throttle opening is fixed to 6°.)

9. ECM OPERATION AT DTC SETTING

Memorize the freeze frame data. (For test mode \$02)

Diagnostic Trouble Code (DTC) Detecting Criteria

GENERAL DESCRIPTION

CF:DTC P0691 FAN 1 CONTROL CIRCUIT LOW

1. OUTLINE OF DIAGNOSIS

Detect the open or short circuit of radiator fan circuit.

Judge as NG when the ECM output level differs from the actual terminal level.

2. ENABLE CONDITION

Secondary Parameters	Enable Conditions
None	

3. GENERAL DRIVING CYCLE

Always perform the diagnosis continuously.

4. DIAGNOSTIC METHOD

Abnormality Judgment

Judge as NG when the continuous time of meeting the malfunction criteria below becomes more than 2.5 seconds.

Judgment Value

Malfunction Criteria	Threshold Value
After engine starting	1 second or more
Engine speed	≥ 500 rpm
Ignition switch	ON
Battery voltage	≥ 10.9 V
Terminal voltage level when ECM outputs OFF signal	Low level

Time Needed for Diagnosis: 2.5 seconds

Malfunction Indicator Light Illumination: Illuminates when malfunction occurs in 2 continuous driving cycles.

Normality Judgment

Judge as OK and clear the NG when the malfunction criteria below are met.

Judgment Value

Malfunction Criteria	Threshold Value
After engine starting	1 second or more
Engine speed	≥ 500 rpm
Ignition switch	ON
Battery voltage	≥ 10.9 V
Terminal voltage level when ECM outputs OFF signal	High level

5. DTC CLEAR CONDITION

- When the OK idling cycle is completed 40 times in a row
- When "Clear Memory" is performed

6. MALFUNCTION INDICATOR LIGHT CLEAR CONDITION

- When the OK driving cycle is completed 3 times in a row
- When "Clear Memory" is performed

7. FAIL SAFE

None

8. ECM OPERATION AT DTC SETTING

Memorize the freeze frame data. (For test mode \$02)

Diagnostic Trouble Code (DTC) Detecting Criteria

GENERAL DESCRIPTION

CG:DTC P0692 FAN 1 CONTROL CIRCUIT HIGH

1. OUTLINE OF DIAGNOSIS

Detect the open or short circuit of radiator fan circuit.

Judge as NG when the ECM output level differs from the actual terminal level.

2. ENABLE CONDITION

Secondary Parameters	Enable Conditions
None	

3. GENERAL DRIVING CYCLE

Always perform the diagnosis continuously.

4. DIAGNOSTIC METHOD

Abnormality Judgment

Judge as NG when the continuous time of meeting the malfunction criteria below becomes more than 2.5 seconds.

Judgment Value

Malfunction Criteria	Threshold Value
After engine starting	1 second or more
Engine speed	≥ 500 rpm
Ignition switch	ON
Battery voltage	≥ 10.9 V
Terminal voltage level when ECM outputs ON signal	High level

Time Needed for Diagnosis: 2.5 seconds

Malfunction Indicator Light Illumination: Illuminates when malfunction occurs in 2 continuous driving cycles.

Normality Judgment

Judge as OK and clear the NG when the malfunction criteria below are met.

Judgment Value

Malfunction Criteria	Threshold Value
After engine starting	1 second or more
Engine speed	≥ 500 rpm
Ignition switch	ON
Battery voltage	≥ 10.9 V
Terminal voltage level when ECM outputs ON signal	Low level

5. DTC CLEAR CONDITION

- When the OK idling cycle is completed 40 times in a row
- When "Clear Memory" is performed

6. MALFUNCTION INDICATOR LIGHT CLEAR CONDITION

- When the OK driving cycle is completed 3 times in a row
- When "Clear Memory" is performed

7. FAIL SAFE

None

8. ECM OPERATION AT DTC SETTING

Memorize the freeze frame data. (For test mode \$02)

Diagnostic Trouble Code (DTC) Detecting Criteria

GENERAL DESCRIPTION

CH:DTC P0700 TRANSMISSION CONTROL SYSTEM (MIL REQUEST)

1. OUTLINE OF DIAGNOSIS

CAN communication is established with AT and, judge as NG when there is a MIL lighting request.

2. ENABLE CONDITION

Secondary Parameters	Enable Conditions
Battery voltage	≥ 10.9 V

3. GENERAL DRIVING CYCLE

Always perform the diagnosis continuously.

4. DIAGNOSTIC METHOD

Judge as NG when the continuous time of meeting the malfunction criteria below becomes more than pre-determined amount of time (2.5 seconds).

Judge as OK and clear the NG when the following conditions are not met.

Judgment Value

Malfunction Criteria	Threshold Value
MIL lighting request from TCM	set

Time Needed for Diagnosis: 2.5 seconds

Malfunction Indicator Light Illumination: Illuminates as soon as a malfunction occurs.

5. DTC CLEAR CONDITION

- When the OK idling cycle is completed 40 times in a row
- When "Clear Memory" is performed

6. MALFUNCTION INDICATOR LIGHT CLEAR CONDITION

- When the OK driving cycle is completed 3 times in a row
- When "Clear Memory" is performed

7. FAIL SAFE

None

8. ECM OPERATION AT DTC SETTING

Memorize the freeze frame data. (For test mode \$02)

Diagnostic Trouble Code (DTC) Detecting Criteria

GENERAL DESCRIPTION

CI: DTC P0851 PARK/NEUTRAL SWITCH INPUT CIRCUIT LOW (AT MODEL)

1. OUTLINE OF DIAGNOSIS

Detect the open or short circuit of the neutral SW.

Judge NG when the ECM neutral terminal input differs from the reception data from TCM.

2. ENABLE CONDITION

Secondary Parameters	Enable Conditions
Ignition switch	ON
Battery voltage	≥ 10.9 V
After engine starting	2 seconds or more
Starter switch	OFF

3. GENERAL DRIVING CYCLE

Perform the diagnosis continuously in 2 seconds after starting the engine.

4. DIAGNOSTIC METHOD

Judge as NG when the continuous time of meeting the malfunction criteria below becomes more than 2.56 seconds. Judge as OK and clear the NG when the malfunction criteria below are not met.

Judgment Value

Malfunction Criteria	Threshold Value
Neutral switch signal when park/neutral = "OFF" and any other switches = "ON" on AT	LOW (ON)

Time Needed for Diagnosis: 2.56 seconds

Malfunction Indicator Light Illumination: Illuminates when malfunction occurs in 2 continuous driving cycles.

5. DTC CLEAR CONDITION

- When the OK idling cycle is completed 40 times in a row
- When "Clear Memory" is performed

6. MALFUNCTION INDICATOR LIGHT CLEAR CONDITION

- When the OK driving cycle is completed 3 times in a row
- When "Clear Memory" is performed

7. FAIL SAFE

Control of cruise control: Not allowed to control.

8. ECM OPERATION AT DTC SETTING

Memorize the freeze frame data. (For test mode \$02)

Diagnostic Trouble Code (DTC) Detecting Criteria

GENERAL DESCRIPTION

CJ:DTC P0851 NEUTRAL SWITCH INPUT CIRCUIT LOW (MT MODEL)

1. OUTLINE OF DIAGNOSIS

Detect the open or short circuit of the neutral SW.

Judge NG when there is no change in the neutral SW even if the driving shift was applied. (There is neutral SW ON/OFF inversion from the vehicle speed and engine speed.)

2. ENABLE CONDITION

Secondary Parameters	Enable Conditions
Ignition switch	ON
Battery voltage	≥ 10.9 V
After engine starting	2 seconds or more
Starter switch	OFF

3. GENERAL DRIVING CYCLE

Perform the diagnosis continuously in 2 seconds after starting the engine.

4. DIAGNOSTIC METHOD

Judge NG when the malfunction criteria below are completed 3 time or more after the neutral SW change. Judge as OK and clear the NG if there is change in the neutral SW.

Judgment Value

Malfunction Criteria	Threshold Value
Neutral switch signal (while changing from a to b below)	LOW (ON)
Driving condition change	a) to b)
a) Vehicle speed = 0 km/h (0 MPH) and engine speed 600 — 900 rpm	
b) Vehicle speed ≥ 64 km/h (40 MPH) and engine speed 1600 — 2550 rpm	

Time Needed for Diagnosis: Monitoring 3 times

Malfunction Indicator Light Illumination: Illuminates when malfunction occurs in 2 continuous driving cycles.

5. DTC CLEAR CONDITION

- When the OK idling cycle is completed 40 times in a row
- When “Clear Memory” is performed

6. MALFUNCTION INDICATOR LIGHT CLEAR CONDITION

- When the OK driving cycle is completed 3 times in a row
- When “Clear Memory” is performed

7. FAIL SAFE

Control of cruise control: Not allowed to control.

8. ECM OPERATION AT DTC SETTING

Memorize the freeze frame data. (For test mode \$02)

Diagnostic Trouble Code (DTC) Detecting Criteria

GENERAL DESCRIPTION

CK:DTC P0852 PARK/NEUTRAL SWITCH INPUT CIRCUIT HIGH (AT MODEL)

1. OUTLINE OF DIAGNOSIS

Judge the open or short circuit of the neutral SW.

Judge NG when the ECM neutral terminal input differs from the reception data from TCM.

2. ENABLE CONDITION

Secondary Parameters	Enable Conditions
Ignition switch	ON
Battery voltage	≥ 10.9 V
After engine starting	2 seconds or more
Starter switch	OFF

3. GENERAL DRIVING CYCLE

Perform the diagnosis continuously in 2 seconds after starting the engine.

4. DIAGNOSTIC METHOD

Judge as NG when the continuous time until meeting the malfunction criteria below becomes 2.56 seconds.

Judge as OK and clear the NG when the malfunction criteria below are not met.

Judgment Value

Malfunction Criteria	Threshold Value
Neutral switch signal when park/neutral = "ON" and any other switches = "OFF" on AT	HIGH (OFF)

Time Needed for Diagnosis: 2.56 seconds

Malfunction Indicator Light Illumination: Illuminates when malfunction occurs in 2 continuous driving cycles.

5. DTC CLEAR CONDITION

- When the OK idling cycle is completed 40 times in a row
- When "Clear Memory" is performed

6. MALFUNCTION INDICATOR LIGHT CLEAR CONDITION

- When the OK driving cycle is completed 3 times in a row
- When "Clear Memory" is performed

7. FAIL SAFE

Control of cruise control: Not allowed to control.

8. ECM OPERATION AT DTC SETTING

Memorize the freeze frame data. (For test mode \$02)

Diagnostic Trouble Code (DTC) Detecting Criteria

GENERAL DESCRIPTION

CL:DTC P0852 NEUTRAL SWITCH INPUT CIRCUIT HIGH (MT MODEL)

1. OUTLINE OF DIAGNOSIS

Judge the open or short circuit of the neutral SW.

Judge NG when there is no change in the neutral SW even if the driving shift was applied. (There is neutral SW ON/OFF inversion from the vehicle speed and engine speed.)

2. ENABLE CONDITION

Secondary Parameters	Enable Conditions
Ignition switch	ON
Battery voltage	≥ 10.9 V
After engine starting	2 seconds or more
Starter switch	OFF

3. GENERAL DRIVING CYCLE

Perform the diagnosis continuously in 2 seconds after starting the engine.

4. DIAGNOSTIC METHOD

Judge NG when the malfunction criteria below are completed 3 time or more after the neutral SW change. Judge as OK and clear the NG if there is change in the neutral SW.

Judgment Value

Malfunction Criteria	Threshold Value
Neutral switch signal (while changing from a to b below)	HIGH (OFF)
Driving condition change	a) to b)
a) Vehicle speed = 0 km/h (0 MPH) and engine speed 600 — 900 rpm	
b) Vehicle speed ≥ 64 km/h (40 MPH) and engine speed 1600 — 2550 rpm	

Time Needed for Diagnosis: Monitoring 3 times

Malfunction Indicator Light Illumination: Illuminates when malfunction occurs in 2 continuous driving cycles.

5. DTC CLEAR CONDITION

- When the OK idling cycle is completed 40 times in a row
- When “Clear Memory” is performed

6. MALFUNCTION INDICATOR LIGHT CLEAR CONDITION

- When the OK driving cycle is completed 3 times in a row
- When “Clear Memory” is performed

7. FAIL SAFE

Control of cruise control: Not allowed to control.

8. ECM OPERATION AT DTC SETTING

Memorize the freeze frame data. (For test mode \$02)

Diagnostic Trouble Code (DTC) Detecting Criteria

GENERAL DESCRIPTION

CM:DTC P1152 O2 SENSOR CIRCUIT RANGE/PERFORMANCE (LOW) (BANK 1 SENSOR 1)

1. OUTLINE OF DIAGNOSIS

Detect that λ value remains Low.

Judge as NG when lambda value is abnormal in accordance with λ value of front oxygen (A/F) sensor and running conditions such as vehicle speed, amount of intake air, engine coolant temperature, sub feedback control, etc.

λ value = Actual air fuel ratio/Theoretical air fuel ratio

$\lambda > 1$: Lean

$\lambda < 1$: Rich

2. COMPONENT DESCRIPTION

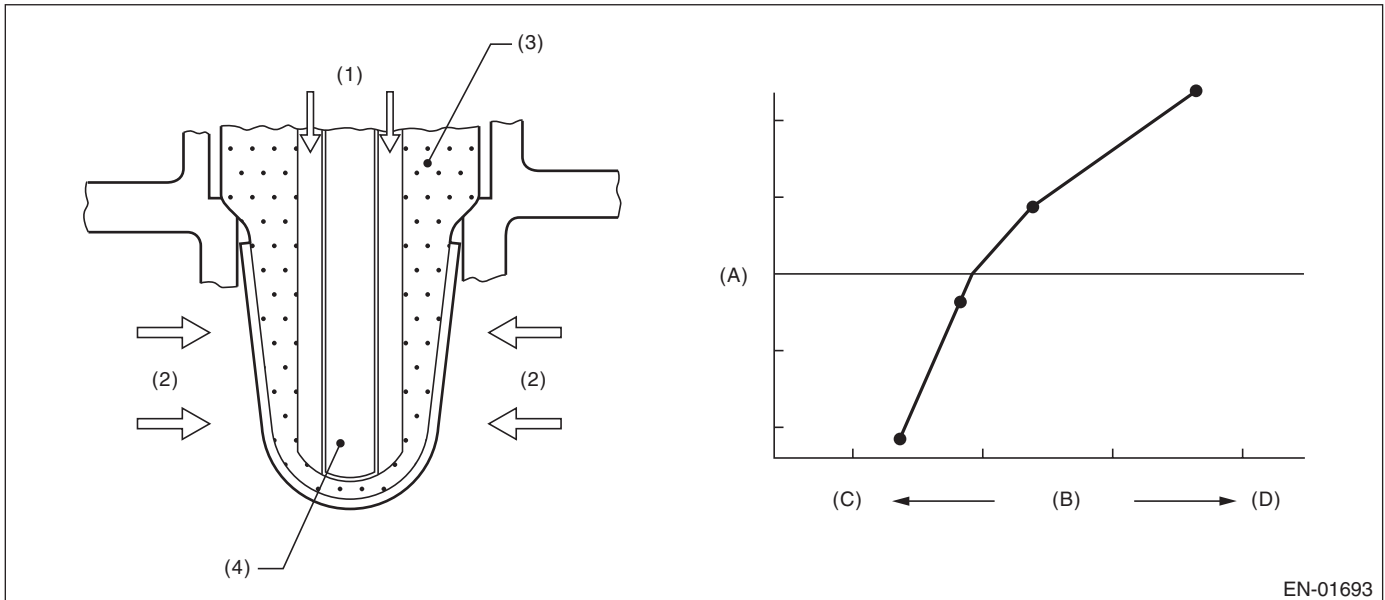

EN-01693

- (1) Atmosphere
- (2) Exhaust gas
- (3) ZrO₂
- (4) Ceramic heater

- (A) Electromotive force
- (B) Air fuel ratio
- (C) Lean
- (D) Rich

Diagnostic Trouble Code (DTC) Detecting Criteria

GENERAL DESCRIPTION

3. ENABLE CONDITION

Secondary Parameters	Enable Conditions
All secondary parameters enable conditions	4 seconds or more
Battery voltage	> 10.9 V
Atmospheric pressure	> 75.1 kPa (563 mmHg, 22.2 inHg)
Rear oxygen sensor sub feedback	Execution
Rear oxygen sensor output voltage – Feedback target voltage	–0.2 V — 0.1 V
Or rear oxygen sensor sub feedback compensation coefficient	On Min.
Or rear oxygen sensor sub feedback compensation coefficient	On Max.
After engine starting	60 seconds or more
Engine coolant temperature	≥ 75°C (167°F)
Vehicle speed	≥ 20 km/h (12 MPH)
Amount of intake air	≥ 6 g (0.21 oz)/s
Load change during 0.5 engine revs.	≤ 0.02 g (0.001 oz)/rev
Front oxygen (A/F) sensor impedance	0 — 50 Ω
Learning value of evaporation gas density	≤ 0.2
Total time of operating canister purge	20 seconds or more
Target lambda load compensation coefficient	–0.03 — 0

4. GENERAL DRIVING CYCLE

Perform diagnosis continuously at a constant speed of 20 km/h (12 MPH) or more after 60 seconds have passed since the engine started.

5. DIAGNOSTIC METHOD

Judge as NG when the continuous time of meeting the malfunction criteria below becomes more than 10 seconds. Judge as OK and clear the NG when the malfunction criteria below are not met.

Judgment Value

Malfunction Criteria	Threshold Value
λ value when rear oxygen sensor sub feedback compensation coefficient is not at maximum limit	≤ 0.85

Time Needed for Diagnosis: 10 seconds

Malfunction Indicator Light Illumination: Illuminates when malfunction occurs in 2 continuous driving cycles.

6. DTC CLEAR CONDITION

- When the OK idling cycle is completed 40 times in a row
- When “Clear Memory” is performed

7. MALFUNCTION INDICATOR LIGHT CLEAR CONDITION

- When the OK driving cycle is completed 3 times in a row
- When “Clear Memory” is performed

8. FAIL SAFE

- Front oxygen (A/F) sensor main learning compensation: Not allowed to calculate.
- Front oxygen (A/F) sensor sub learning compensation: Not allowed to calculate.
- Purge control: Not allowed to purge.

9. ECM OPERATION AT DTC SETTING

Memorize the freeze frame data. (For test mode \$02)

Diagnostic Trouble Code (DTC) Detecting Criteria

GENERAL DESCRIPTION

CN:DTC P1153 O2 SENSOR CIRCUIT RANGE/PERFORMANCE (HIGH) (BANK 1 SENSOR 1)

1. OUTLINE OF DIAGNOSIS

Detect that λ value remains High.

Judge as NG when lambda value is abnormal in accordance with λ value of front oxygen (A/F) sensor and running conditions such as vehicle speed, amount of intake air, engine coolant temperature, sub feedback control, etc.

λ value = Actual air fuel ratio/Theoretical air fuel ratio

$\lambda > 1$: Lean

$\lambda < 1$: Rich

2. COMPONENT DESCRIPTION

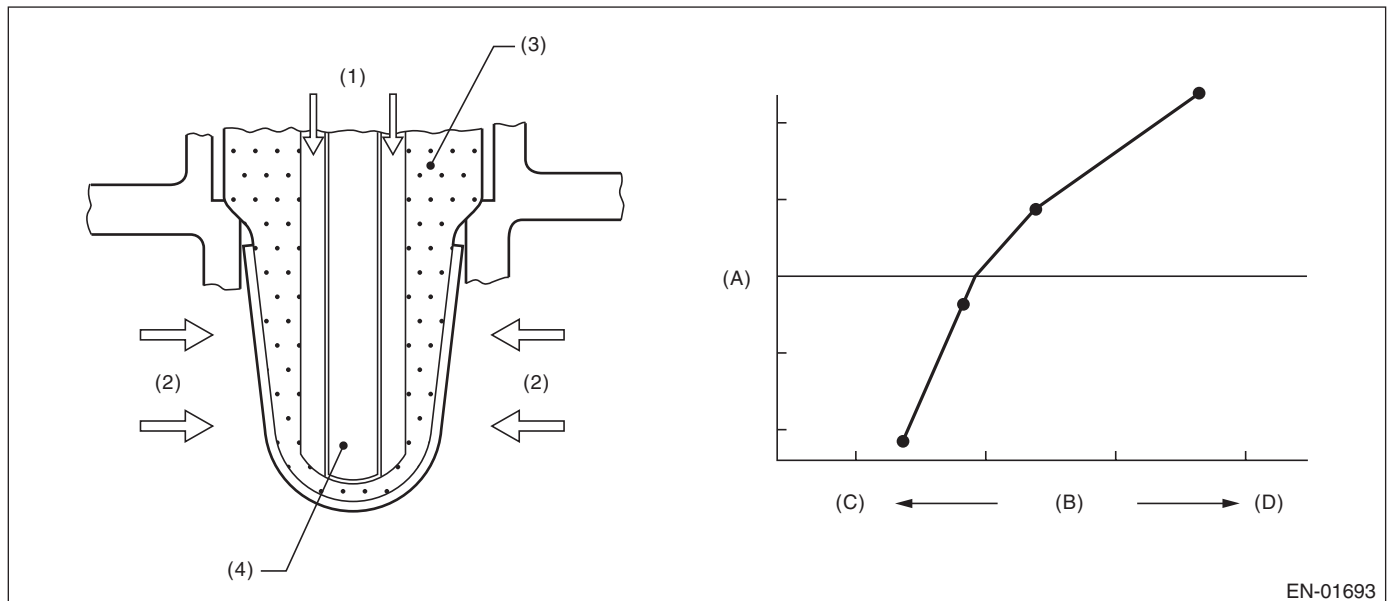

EN-01693

- (1) Atmosphere
- (2) Exhaust gas
- (3) ZrO₂
- (4) Ceramic heater

- (A) Electromotive force
- (B) Air fuel ratio
- (C) Lean
- (D) Rich

Diagnostic Trouble Code (DTC) Detecting Criteria

GENERAL DESCRIPTION

3. ENABLE CONDITION

Secondary Parameters	Enable Conditions
All secondary parameters enable conditions	4 seconds or more
Battery voltage	> 10.9 V
Atmospheric pressure	> 75.1 kPa (563 mmHg, 22.2 inHg)
Rear oxygen sensor sub feedback	Execution
Rear oxygen sensor output voltage – Feedback target voltage	–0.2 V — 0.1 V
Or rear oxygen sensor sub feedback compensation coefficient	On Min.
Or rear oxygen sensor sub feedback compensation coefficient	On Max.
After engine starting	60 seconds or more
Engine coolant temperature	≥ 75°C (167°F)
Vehicle speed	≥ 20 km/h (12 MPH)
Amount of intake air	≥ 6 g (0.21 oz)/s
Load change during 0.5 engine revs.	≤ 0.02 g (0.001 oz)/rev
Front oxygen (A/F) sensor impedance	0 — 50 Ω
Learning value of evaporation gas density	≤ 0.2
Total time of operating canister purge	20 seconds or more
Target lambda load compensation coefficient	–0.03 — 0

4. GENERAL DRIVING CYCLE

Perform diagnosis continuously at a constant vehicle speed of 20 km/h (12 MPH) or more after 60 seconds have passed since the engine started.

5. DIAGNOSTIC METHOD

Judge as NG when the continuous time of meeting the malfunction criteria below becomes more than 10 seconds. Judge as OK and clear the NG when the malfunction criteria below are not met.

Judgment Value

Malfunction Criteria	Threshold Value
λ value when rear oxygen sensor sub feedback compensation coefficient cannot be at minimum limit	≥ 1.15

Time Needed for Diagnosis: 10 seconds

Malfunction Indicator Light Illumination: Illuminates when malfunction occurs in 2 continuous driving cycles.

6. DTC CLEAR CONDITION

- When the OK idling cycle is completed 40 times in a row
- When “Clear Memory” is performed

7. MALFUNCTION INDICATOR LIGHT CLEAR CONDITION

- When the OK driving cycle is completed 3 times in a row
- When “Clear Memory” is performed

8. FAIL SAFE

- Front oxygen (A/F) sensor main learning compensation: Not allowed to calculate.
- Front oxygen (A/F) sensor sub learning compensation: Not allowed to calculate.
- Purge control: Not allowed to purge.

9. ECM OPERATION AT DTC SETTING

Memorize the freeze frame data. (For test mode \$02)

Diagnostic Trouble Code (DTC) Detecting Criteria

GENERAL DESCRIPTION

CO:DTC P1160 RETURN SPRING FAILURE

1. OUTLINE OF DIAGNOSIS

Judge as NG when the valve does not move to the close direction with the motor power stopped and the valve open more than the default opening.

2. COMPONENT DESCRIPTION

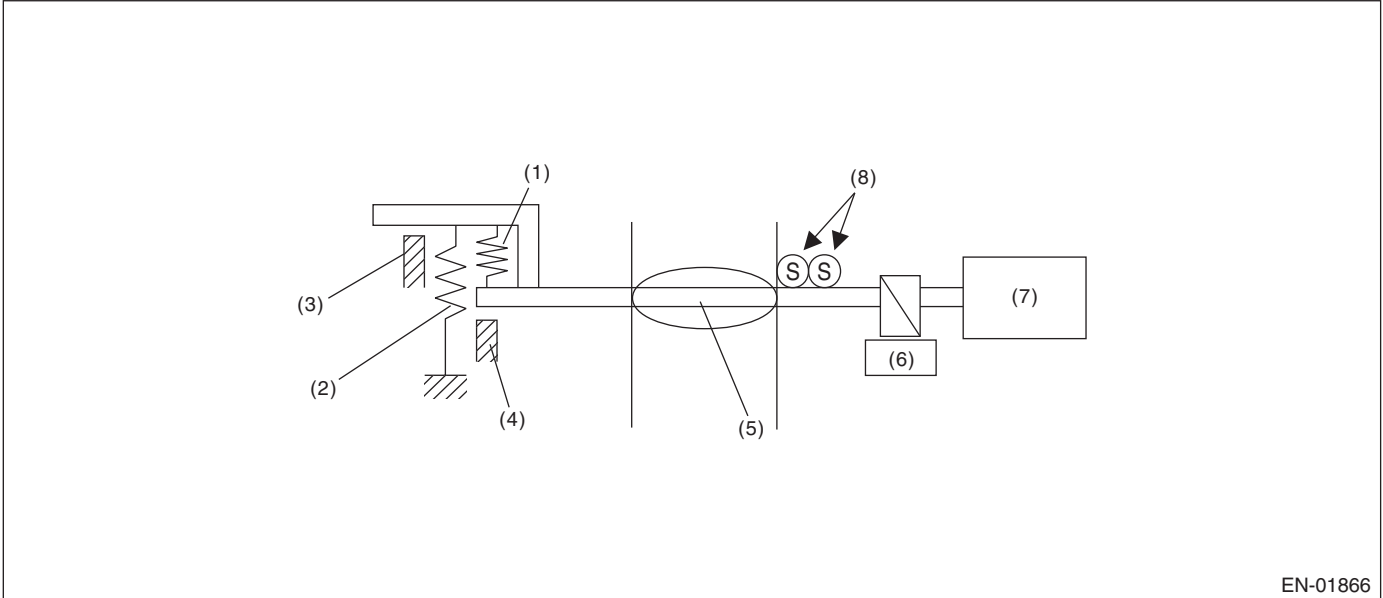

EN-01866

- | | | |
|--------------------------|-------------------------|----------------------------------|
| (1) Opener spring | (4) Full closed stopper | (7) DC motor |
| (2) Return spring | (5) Throttle valve | (8) Main and sub throttle sensor |
| (3) Intermediate stopper | (6) Gear | |

3. ENABLE CONDITION

Secondary Parameters	Enable Conditions
Throttle opening angle	OFF
Motor continuity	OFF

4. GENERAL DRIVING CYCLE

- Ignition switch ON → OFF
- Ignition switch OFF → ON (Only after clearing memory)

5. DIAGNOSTIC METHOD

Judge as OK and clear the NG when the malfunction criteria below are met.

Judgment Value

Malfunction Criteria	Threshold Value
Opening variation after continuity is set to OFF	$\geq 2^\circ$

Time Needed for Diagnosis: 1880 milliseconds

Malfunction Indicator Light Illumination: Illuminates as soon as a malfunction occurs.

6. DTC CLEAR CONDITION

- When the OK idling cycle is completed 40 times in a row
- When "Clear Memory" is performed (Only with engine stopped)

Diagnostic Trouble Code (DTC) Detecting Criteria

GENERAL DESCRIPTION

7. MALFUNCTION INDICATOR LIGHT CLEAR CONDITION

- When the OK driving cycle is completed 3 times in a row
- When "Clear Memory" is performed (Only with engine stopped)

8. FAIL SAFE

Throttle opening is fixed to 6°.

9. ECM OPERATION AT DTC SETTING

Memorize the freeze frame data. (For test mode \$02)

Diagnostic Trouble Code (DTC) Detecting Criteria

GENERAL DESCRIPTION

CP:DTC P1400 FUEL TANK PRESSURE CONTROL SOLENOID VALVE CIRCUIT LOW

1. OUTLINE OF DIAGNOSIS

Detect the open/short circuit of pressure control solenoid valve.

Judge as NG when ECM output level is different from actual terminal level.

2. COMPONENT DESCRIPTION

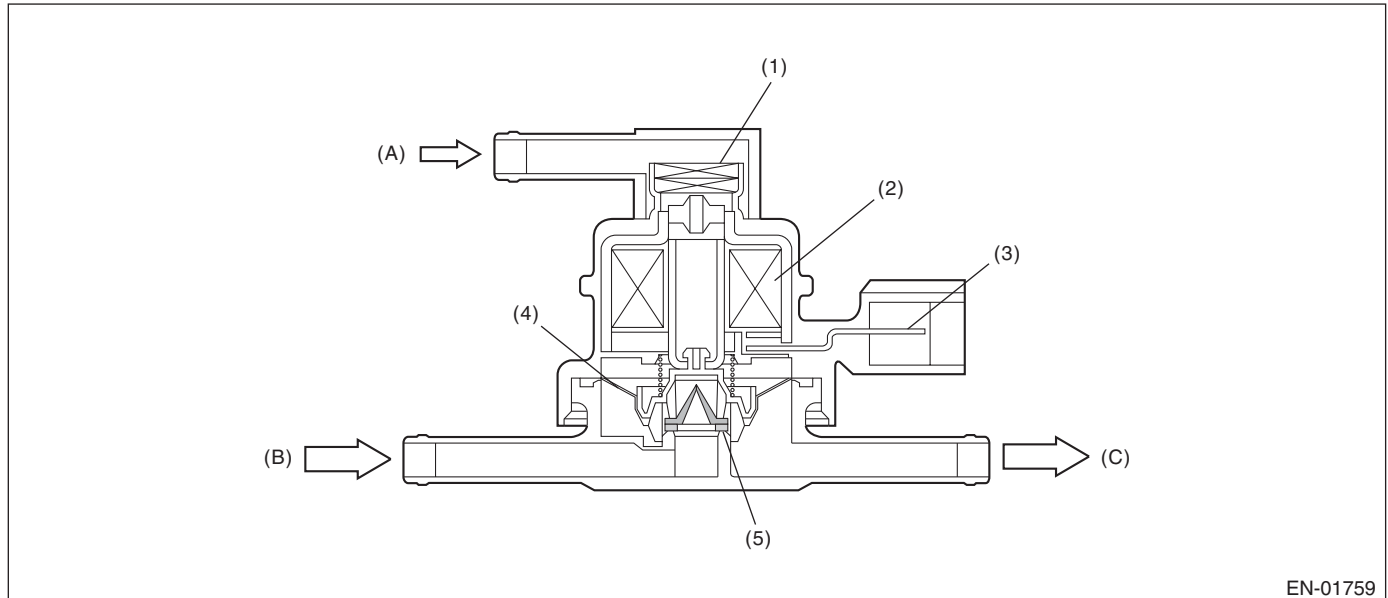

EN-01759

- | | | |
|------------------------|---------------|--------------------------|
| (1) Filter | (4) Diaphragm | (A) Atmospheric pressure |
| (2) Coil | (5) Valve | (B) Shut-off valve |
| (3) Connector terminal | | (C) To fuel tank |

3. ENABLE CONDITION

Secondary Parameters	Enable Conditions
Ignition switch	ON
Battery voltage	$\geq 10.9 \text{ V}$
After engine starting	1 second or more

4. GENERAL DRIVING CYCLE

Always perform the diagnosis after starting the engine.

5. DIAGNOSTIC METHOD

Judge as NG when the continuous time of meeting the malfunction criteria below becomes more than time needed for diagnosis (2.5 seconds). Judge as OK and clear the NG when the malfunction criteria below are not met.

Judgment Value

Malfunction Criteria	Threshold Value
Terminal output voltage when ECM outputs OFF signal	Low

Time Needed for Diagnosis: 2.5 seconds

Malfunction Indicator Light Illumination: Illuminates when malfunction occurs in 2 continuous driving cycles.

Diagnostic Trouble Code (DTC) Detecting Criteria

GENERAL DESCRIPTION

6. DTC CLEAR CONDITION

- When the OK idling cycle is completed 40 times in a row
- When "Clear Memory" is performed

7. MALFUNCTION INDICATOR LIGHT CLEAR CONDITION

- When the OK driving cycle is completed 3 times in a row
- When "Clear Memory" is performed

8. FAIL SAFE

None

9. ECM OPERATION AT DTC SETTING

Memorize the freeze frame data. (For test mode \$02)

Diagnostic Trouble Code (DTC) Detecting Criteria

GENERAL DESCRIPTION

CQ:DTC P1420 FUEL TANK PRESSURE CONTROL SOL. VALVE CIRCUIT HIGH

1. OUTLINE OF DIAGNOSIS

Detect the open/short circuit of pressure control solenoid valve.

Judge as NG when ECM output level is different from actual terminal level.

2. COMPONENT DESCRIPTION

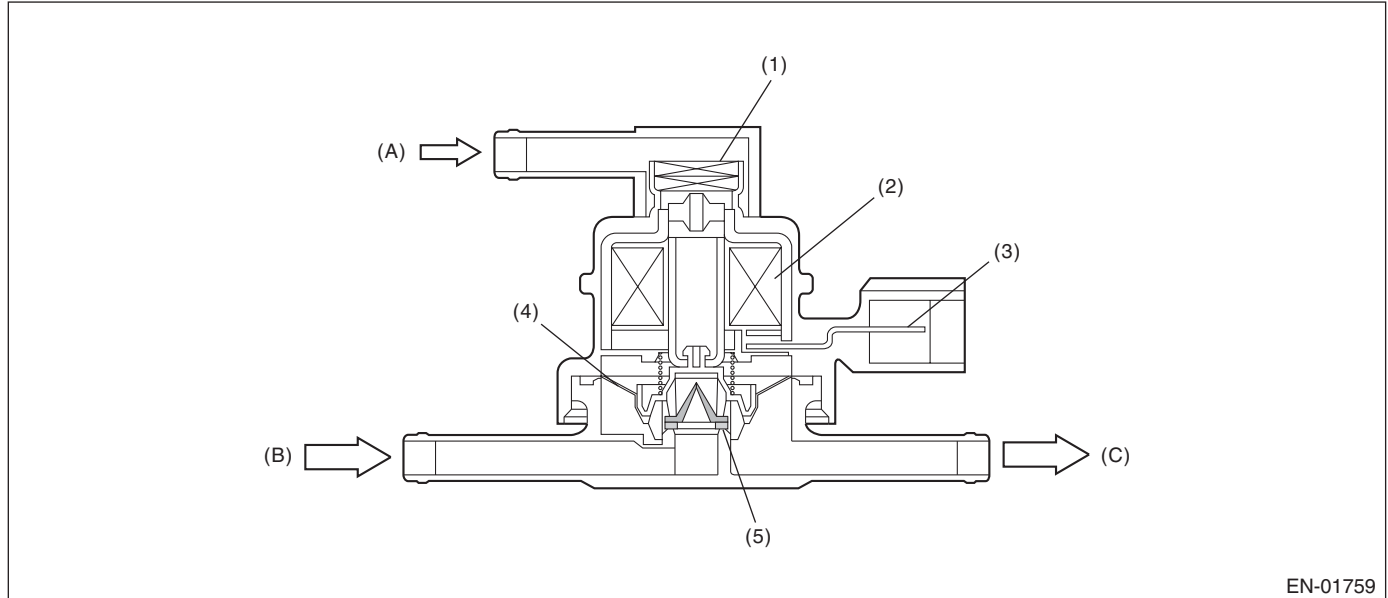

- | | | |
|------------------------|---------------|--------------------------|
| (1) Filter | (4) Diaphragm | (A) Atmospheric pressure |
| (2) Coil | (5) Valve | (B) Shut-off valve |
| (3) Connector terminal | | (C) To fuel tank |

3. ENABLE CONDITION

Secondary Parameters	Enable Conditions
Ignition switch	ON
Battery voltage	$\geq 10.9 \text{ V}$
After engine starting	1 second or more

4. GENERAL DRIVING CYCLE

Always perform the diagnosis after starting the engine.

5. DIAGNOSTIC METHOD

Judge as NG when the continuous time of meeting the malfunction criteria below becomes more than time needed for diagnosis (2.5 seconds). Judge as OK and clear the NG when the malfunction criteria below are not met.

Judgment Value

Malfunction Criteria	Threshold Value
Terminal output voltage when ECM outputs ON signal	High

Time Needed for Diagnosis: 2.5 seconds

Malfunction Indicator Light Illumination: Illuminates when malfunction occurs in 2 continuous driving cycles.

6. DTC CLEAR CONDITION

- When the OK idling cycle is completed 40 times in a row
- When "Clear Memory" is performed

Diagnostic Trouble Code (DTC) Detecting Criteria

GENERAL DESCRIPTION

7. MALFUNCTION INDICATOR LIGHT CLEAR CONDITION

- When the OK driving cycle is completed 3 times in a row
- When "Clear Memory" is performed

8. FAIL SAFE

None

9. ECM OPERATION AT DTC SETTING

Memorize the freeze frame data. (For test mode \$02)

Diagnostic Trouble Code (DTC) Detecting Criteria

GENERAL DESCRIPTION

CR:DTC P1443 VENT CONTROL SOLENOID VALVE FUNCTION PROBLEM

1. OUTLINE OF DIAGNOSIS

Detect the abnormal function (stuck closed) of the drain valve.
Judge as NG when fuel tank pressure is low.

2. COMPONENT DESCRIPTION

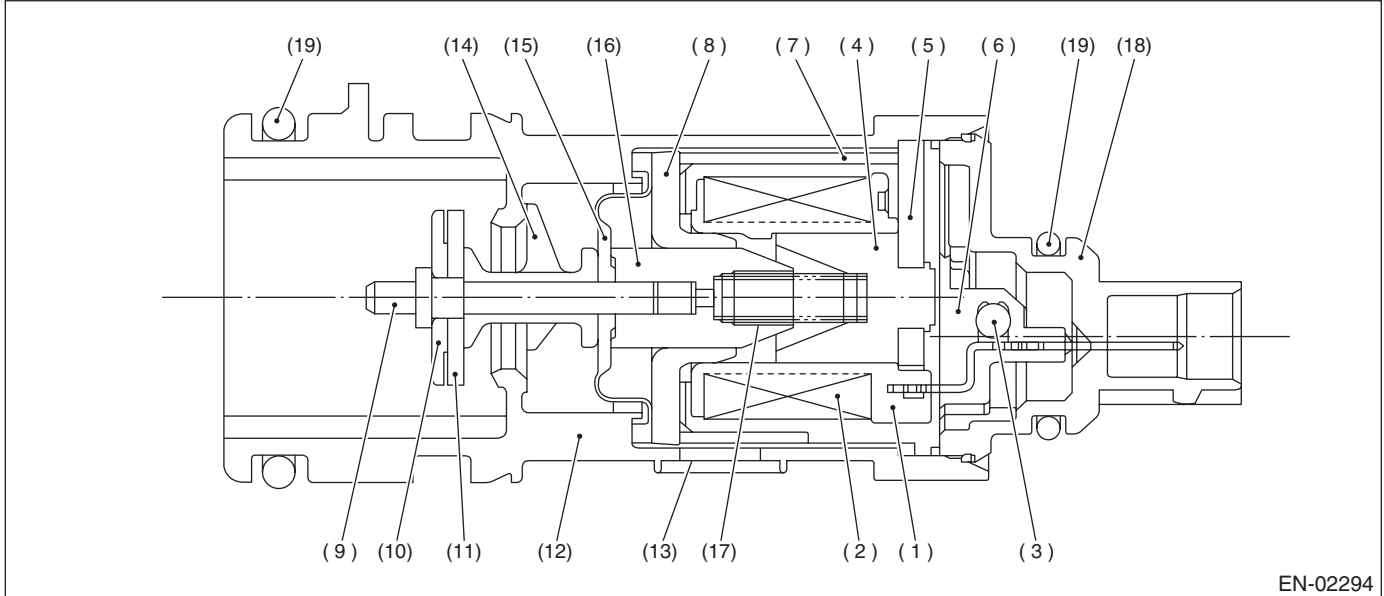

- | | | |
|-----------------|--------------------|-------------------|
| (1) Bobbin | (8) Magnetic plate | (15) Diaphragm |
| (2) Coil | (9) Shaft | (16) Movable core |
| (3) Diode | (10) Plate | (17) Spring |
| (4) Stator core | (11) Valve | (18) Cover |
| (5) End plate | (12) Housing | (19) O-ring |
| (6) Body | (13) Filter | |
| (7) Yoke | (14) Retainer | |

3. ENABLE CONDITION

Secondary Parameters	Enable Conditions
Drain valve	Open
Battery voltage	≥ 10.9 V
Atmospheric pressure	≥ 75.0 kPa (563 mmHg, 22.17 inHg)
Tank pressure when starter is OFF → ON	-0.7 — 1.4 kPa (-5 — 10.7 mmHg, -0.20 — 0.42 inHg)

4. GENERAL DRIVING CYCLE

Always perform the diagnosis continuously.

Diagnostic Trouble Code (DTC) Detecting Criteria

GENERAL DESCRIPTION

5. DIAGNOSTIC METHOD

Abnormality Judgment

Judge as NG when the continuous time while meeting all of the malfunction criteria below is more than 3 seconds.

Judgment Value

Malfunction Criteria	Threshold Value
Tank pressure	≤ -4.0 kPa (-30 mmHg, -1.18 inHg)

Time Needed for Diagnosis: 3 seconds

Malfunction Indicator Light Illumination: Illuminates as soon as a malfunction occurs.

Normality Judgment

Judge as OK and clear the NG when all the malfunction criteria below are met.

Judgment Value

Malfunction Criteria	Threshold Value
Tank pressure	> -4.0 kPa (-30 mmHg, -1.18 inHg)
Cumulative time when all of the malfunction criteria below is completed.	≥ 30 sec.
Purge control solenoid valve duty ratio	Not = 0
Fuel temp.	-10 — 45°C (14 — 113°F)
Intake manifold relative pressure	≤ -26.7 kPa (-200 mmHg, -7.87 inHg)

6. DTC CLEAR CONDITION

- When the OK idling cycle is completed 40 times in a row
- When "Clear Memory" is performed

7. MALFUNCTION INDICATOR LIGHT CLEAR CONDITION

- When the OK driving cycle is completed 3 times in a row
- When "Clear Memory" is performed

8. FAIL SAFE

Pressure control solenoid valve control: Open the pressure control solenoid valve.

9. ECM OPERATION AT DTC SETTING

Memorize the freeze frame data. (For test mode \$02)

Diagnostic Trouble Code (DTC) Detecting Criteria

GENERAL DESCRIPTION

CS:DTC P1491 POSITIVE CRANKCASE VENTILATION (BLOW-BY) FUNCTION PROBLEM

1. OUTLINE OF DIAGNOSIS

Detect the blow-by hose release abnormality.

Judge as NG when the diagnosis terminal voltage is high.

2. COMPONENT DESCRIPTION

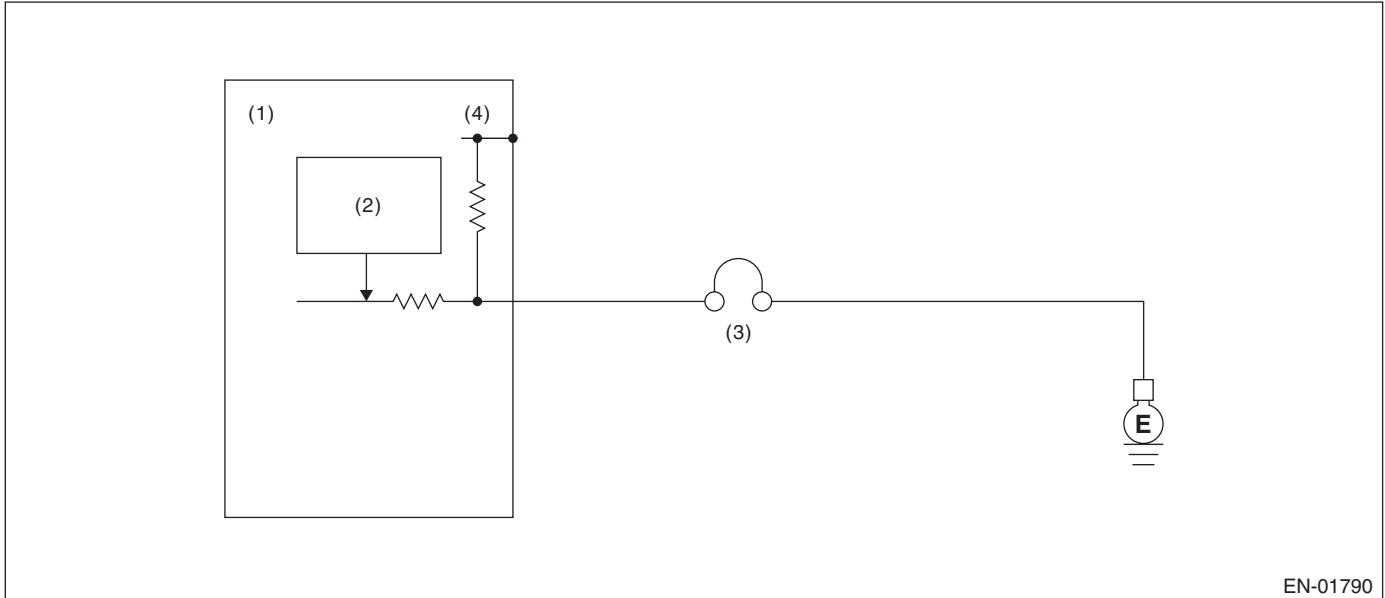

EN-01790

- (1) Engine control module (ECM) (3) PCV diagnosis connector
(2) Detecting circuit (4) 5 V

3. ENABLE CONDITION

Secondary Parameters	Enable Conditions
None	

4. GENERAL DRIVING CYCLE

Always perform the diagnosis continuously.

Diagnostic Trouble Code (DTC) Detecting Criteria

GENERAL DESCRIPTION

5. DIAGNOSTIC METHOD

Abnormality Judgment

Judge as NG when the continuous time with the following criteria established exceeds 2.5 seconds.

Judgment Value

Malfunction Criteria	Threshold Value
Battery voltage	> 10.9 V
Engine speed	≥ 500 rpm
Positive crankcase ventilation diagnosis voltage	High

Time Needed for Diagnosis: 2.5 seconds

Malfunction Indicator Light Illumination: Illuminates as soon as a malfunction occurs.

Normality Judgment

Judge as OK when the following conditions are established after predetermined amount of time has passed.
Judge as OK and clear the NG when the malfunction criteria below are met.

Judgment Value

Malfunction Criteria	Threshold Value
Battery voltage	> 10.9 V
Engine speed	≥ 500 rpm
Positive crankcase ventilation diagnosis voltage	Low

6. DTC CLEAR CONDITION

- When the OK idling cycle is completed 40 times in a row
- When "Clear Memory" is performed

7. MALFUNCTION INDICATOR LIGHT CLEAR CONDITION

- When the OK driving cycle is completed 3 times in a row
- When "Clear Memory" is performed

8. FAIL SAFE

None

9. ECM OPERATION AT DTC SETTING

Memorize the freeze frame data. (For test mode \$02)

Diagnostic Trouble Code (DTC) Detecting Criteria

GENERAL DESCRIPTION

CT:DTC P1492 EGR SOLENOID VALVE SIGNAL #1 CIRCUIT MALFUNCTION (LOW INPUT)

1. OUTLINE OF DIAGNOSIS

- Detects open or short circuit of EGR.
- Judge as NG when the ECM output level differs from the actual terminal level.

2. COMPONENT DESCRIPTION

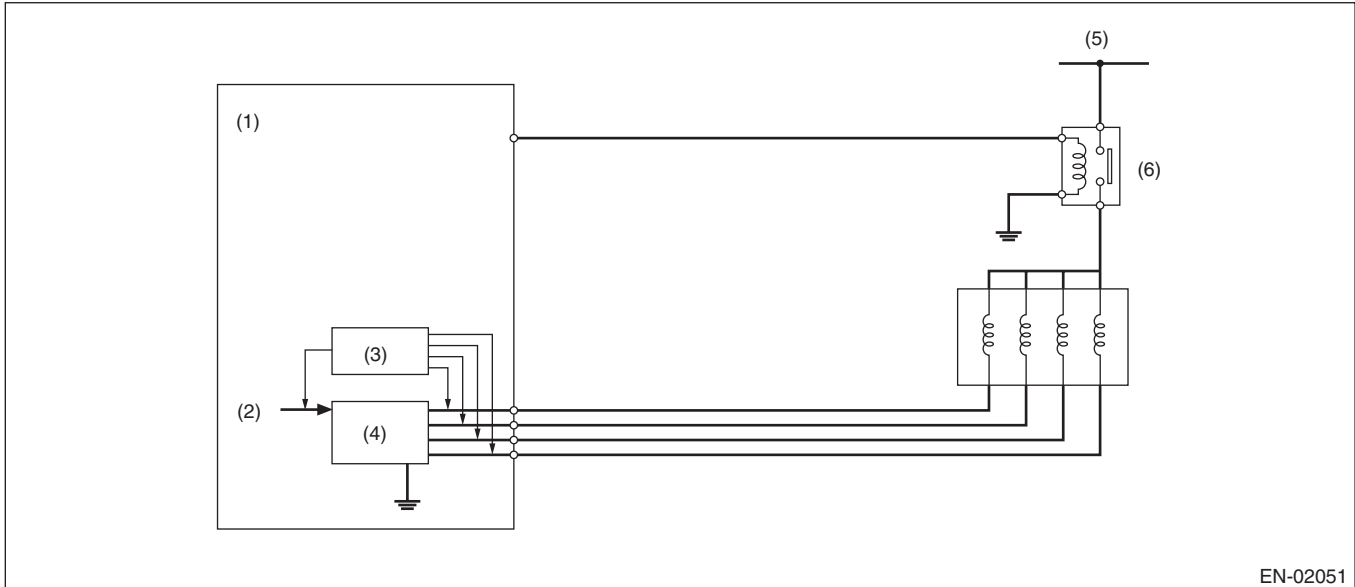

EN-02051

- (1) Engine control module (ECM) (3) Detecting circuit (5) Battery voltage
(2) Computer unit (CPU) (4) Switch circuit (6) Main relay

3. ENABLE CONDITION

Secondary Parameters	Enable Conditions
EGR valve target position	> 0 step
Battery voltage	> 10.9 V

4. GENERAL DRIVING CYCLE

Perform diagnosis continuously during EGR operation.

Diagnostic Trouble Code (DTC) Detecting Criteria

GENERAL DESCRIPTION

5. DIAGNOSTIC METHOD

Abnormality Judgment

Judge as NG when the continuous time with the following criteria established exceeds the predetermined time.

Judgment Value

Malfunction Criteria	Threshold Value
Terminal voltage level when ECM outputs OFF signal	Low level

Time Needed for Diagnosis: 2.5 seconds

Malfunction Indicator Light: Illuminates as soon as a malfunction occurs.

Normality Judgment

Judge as OK and clear the NG when the malfunction criteria below are met.

Judgment Value

Malfunction Criteria	Threshold Value
Terminal voltage level when ECM outputs OFF signal	High level

6. DTC CLEAR CONDITION

- When the OK idling cycle is completed 40 times in a row
- When "Clear Memory" is performed

7. MALFUNCTION INDICATOR LIGHT CLEAR CONDITION

- When the OK driving cycle is completed 3 times in a row
- When "Clear Memory" is performed

8. FAIL SAFE

- Front oxygen (A/F) sensor main learning compensation: Not allowed to calculate.
- Knock sensor learning compensation: Not allowed to calculate.
- EGR control: Not allowed to operate.

9. ECM OPERATION AT DTC SETTING

Memorize the freeze frame data. (For test mode \$02)

Diagnostic Trouble Code (DTC) Detecting Criteria

GENERAL DESCRIPTION

CU:DTC P1493 EGR SOLENOID VALVE SIGNAL #1 CIRCUIT MALFUNCTION (HIGH INPUT)

1. OUTLINE OF DIAGNOSIS

- Detects open or short circuit of EGR.
- Judge as NG when the ECM output level differs from the actual terminal level.

2. COMPONENT DESCRIPTION

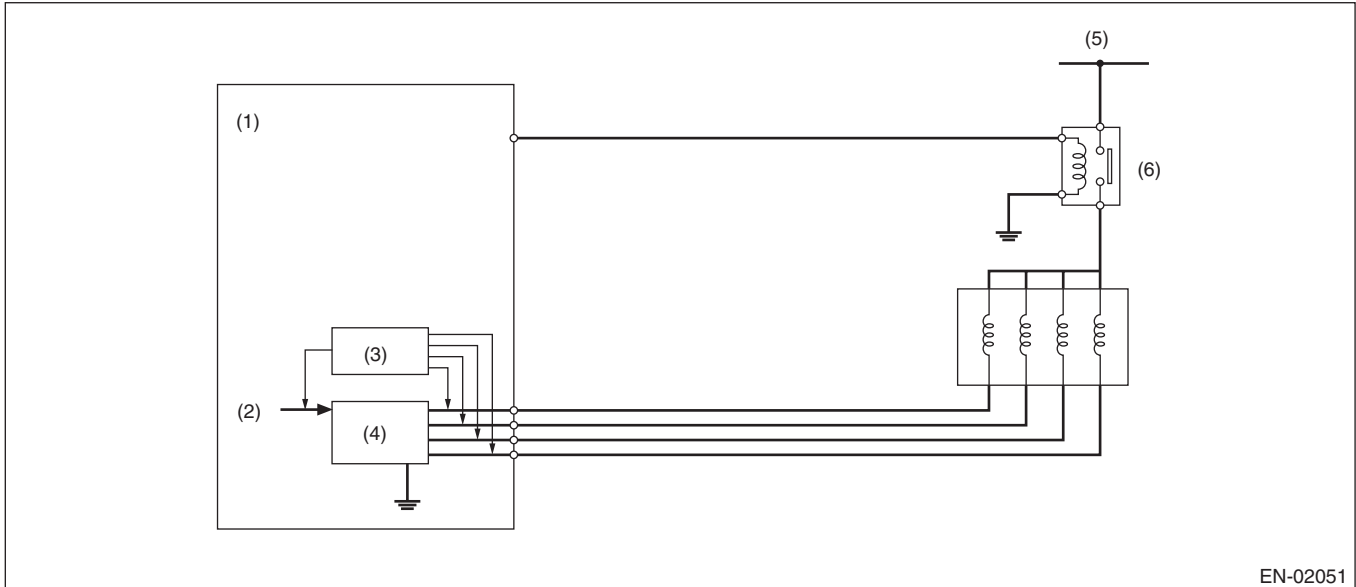

EN-02051

- (1) Engine control module (ECM) (3) Detecting circuit (5) Battery voltage
(2) Computer unit (CPU) (4) Switch circuit (6) Main relay

3. ENABLE CONDITION

Secondary Parameters	Enable Conditions
Battery voltage	> 10.9 V
EGR valve target position	> 0 step

4. GENERAL DRIVING CYCLE

Always perform the diagnosis continuously.

Diagnostic Trouble Code (DTC) Detecting Criteria

GENERAL DESCRIPTION

5. DIAGNOSTIC METHOD

Abnormality Judgment

Judge as NG when the continuous time with the following criteria established exceeds the predetermined time.

Judgment Value

Malfunction Criteria	Threshold Value
Terminal voltage level when ECM outputs ON signal	High level

Time Needed for Diagnosis: 2.5 seconds

Malfunction Indicator Light: Illuminates as soon as a malfunction occurs.

Normality Judgment

Judge as OK and clear the NG when the malfunction criteria below are met.

Judgment Value

Malfunction Criteria	Threshold Value
Terminal voltage level when ECM outputs ON signal	Low level

6. DTC CLEAR CONDITION

- When the OK idling cycle is completed 40 times in a row
- When "Clear Memory" is performed

7. MALFUNCTION INDICATOR LIGHT CLEAR CONDITION

- When the OK driving cycle is completed 3 times in a row
- When "Clear Memory" is performed

8. FAIL SAFE

- Front oxygen (A/F) sensor main learning compensation: Not allowed to calculate.
- Knock sensor learning compensation: Not allowed to calculate.
- EGR control: Not allowed to operate.

9. ECM OPERATION AT DTC SETTING

Memorize the freeze frame data. (For test mode \$02)

Diagnostic Trouble Code (DTC) Detecting Criteria

GENERAL DESCRIPTION

CV:DTC P1494 EGR SOLENOID VALVE SIGNAL #2 CIRCUIT MALFUNCTION (LOW INPUT)

NOTE:

For the detection conditions, refer to DTC P1492. <Ref. to GD(H4SO)-196, DTC P1492 EGR SOLENOID VALVE SIGNAL #1 CIRCUIT MALFUNCTION (LOW INPUT), Diagnostic Trouble Code (DTC) Detecting Criteria.>

CW:DTC P1495 EGR SOLENOID VALVE SIGNAL #2 CIRCUIT MALFUNCTION (HIGH INPUT)

NOTE:

For the detection conditions, refer to DTC P1493. <Ref. to GD(H4SO)-198, DTC P1493 EGR SOLENOID VALVE SIGNAL #1 CIRCUIT MALFUNCTION (HIGH INPUT), Diagnostic Trouble Code (DTC) Detecting Criteria.>

CX:DTC P1496 EGR SOLENOID VALVE SIGNAL #3 CIRCUIT MALFUNCTION (LOW INPUT)

NOTE:

For the detection conditions, refer to DTC P1492. <Ref. to GD(H4SO)-196, DTC P1492 EGR SOLENOID VALVE SIGNAL #1 CIRCUIT MALFUNCTION (LOW INPUT), Diagnostic Trouble Code (DTC) Detecting Criteria.>

CY:DTC P1497 EGR SOLENOID VALVE SIGNAL #3 CIRCUIT MALFUNCTION (HIGH INPUT)

NOTE:

For the detection conditions, refer to DTC P1493. <Ref. to GD(H4SO)-198, DTC P1493 EGR SOLENOID VALVE SIGNAL #1 CIRCUIT MALFUNCTION (HIGH INPUT), Diagnostic Trouble Code (DTC) Detecting Criteria.>

CZ:DTC P1498 EGR SOLENOID VALVE SIGNAL #4 CIRCUIT MALFUNCTION (LOW INPUT)

NOTE:

For the detection conditions, refer to DTC P1492. <Ref. to GD(H4SO)-196, DTC P1492 EGR SOLENOID VALVE SIGNAL #1 CIRCUIT MALFUNCTION (LOW INPUT), Diagnostic Trouble Code (DTC) Detecting Criteria.>

DA:DTC P1499 EGR SOLENOID VALVE SIGNAL #4 CIRCUIT MALFUNCTION (HIGH INPUT)

NOTE:

For the detection conditions, refer to DTC P1493. <Ref. to GD(H4SO)-198, DTC P1493 EGR SOLENOID VALVE SIGNAL #1 CIRCUIT MALFUNCTION (HIGH INPUT), Diagnostic Trouble Code (DTC) Detecting Criteria.>

Diagnostic Trouble Code (DTC) Detecting Criteria

GENERAL DESCRIPTION

DB:DTC P1518 STARTER SWITCH CIRCUIT LOW INPUT

1. OUTLINE OF DIAGNOSIS

Detect the open or short circuit of starter SW.

Judge as OFF NG when the engine starts without starter ON experience.

2. ENABLE CONDITION

Secondary Parameters	Enable Conditions
None	

3. GENERAL DRIVING CYCLE

Always perform the diagnosis continuously.

4. DIAGNOSTIC METHOD

Abnormality Judgment

Judge as OFF NG when the malfunction criteria below are met.

Judgment Value

Malfunction Criteria	Threshold Value
Vehicle speed	< 1 km/h (1 MPH)
Starter ON signal	Not detected
engine speed, after engine speed of less than 500 rpm continues for more than 0.8 seconds.	≥ 500 rpm

Time Needed for Diagnosis: 1 second

Malfunction Indicator Light Illumination: Illuminates when malfunction occurs in 2 continuous driving cycles.

Normality Judgment

Judge as OFF OK and clear the NG when the malfunction criteria below are met.

Judgment Value

Malfunction Criteria	Threshold Value
Starter ON	Experienced
Battery voltage	> 8 V

5. DTC CLEAR CONDITION

- When the OK idling cycle is completed 40 times in a row
- When "Clear Memory" is performed

6. MALFUNCTION INDICATOR LIGHT CLEAR CONDITION

- When the OK driving cycle is completed 3 times in a row
- When "Clear Memory" is performed

7. FAIL SAFE

None

8. ECM OPERATION AT DTC SETTING

Memorize the freeze frame data. (For test mode \$02)

Diagnostic Trouble Code (DTC) Detecting Criteria

GENERAL DESCRIPTION

DC:DTC P1560 BACK-UP VOLTAGE CIRCUIT MALFUNCTION

1. OUTLINE OF DIAGNOSIS

Detect the open/short circuit of back-up power supply circuit.

Judge as NG when the backup voltage becomes smaller than the battery voltage.

2. ENABLE CONDITION

Secondary Parameters	Enable Conditions
None	

3. GENERAL DRIVING CYCLE

Always perform the diagnosis continuously.

4. DIAGNOSTIC METHOD

Abnormality Judgment

Judge as NG when the continuous time with the following criteria established exceeds 2.5 seconds.

Judgment Value

Malfunction Criteria	Threshold Value
Voltage of back-up power supply	Low
Battery voltage	≥ 10.9 V
Engine speed	≥ 500 rpm

Time Needed for Diagnosis: 2.5 seconds

Malfunction Indicator Light Illumination: Illuminates as soon as a malfunction occurs.

Normality Judgment

Judge as OK and clear the NG when the malfunction criteria below are met.

Judgment Value

Malfunction Criteria	Threshold Value
Voltage of back-up power supply	High
Battery voltage	≥ 10.9 V
Engine speed	≥ 500 rpm

5. DTC CLEAR CONDITION

- When the OK idling cycle is completed 40 times in a row
- When "Clear Memory" is performed

6. MALFUNCTION INDICATOR LIGHT CLEAR CONDITION

- When the OK driving cycle is completed 3 times in a row
- When "Clear Memory" is performed

7. FAIL SAFE

None

8. ECM OPERATION AT DTC SETTING

Memorize the freeze frame data. (For test mode \$02)

DD:DTC P1602 CONTROL MODULE PROGRAMMING ERROR

1. OUTLINE OF DIAGNOSIS

Detect the malfunction of catalytic converter initial warm-up retard angle control.

Judge as NG if the ECM is not operating properly when performing catalytic converter initial warm-up retard angle control.

Judge as NG when judged NG in either or both diagnosis of exhaust temperature and diagnosis of idle speed.

- Diagnosis of exhaust temperature

Judge as NG if the exhaust temperature is below the specified value at 14 seconds after a cold start.

- Diagnosis of idle speed

Judge as NG when actual engine speed is not close to target engine speed after stopping retard angle control.

2. ENABLE CONDITION

Secondary Parameters	Enable Conditions
Atmospheric pressure	> 75.1 kPa (563 mmHg, 22.2 inHg)
Battery voltage	> 10.9 V
Diagnosis of cold start	Incomplete
Engine	Start
Vehicle speed	≤ 2 km/h (1 MPH)
Misfire during 200 engine revs.	< 5
Time elapsed after engine start	= 14 seconds

3. GENERAL DRIVING CYCLE

Diagnose at cold start.

Diagnostic Trouble Code (DTC) Detecting Criteria

GENERAL DESCRIPTION

4. DIAGNOSTIC METHOD

- Diagnosis of exhaust temperature

Abnormality Judgment

Calculate the estimated exhaust temperature when the enable conditions for judgment were established. Judge as NG if the following conditions are established within 14 seconds after starting the engine.

Judgment Value

Malfunction Criteria	Threshold Value
Estimated exhaust temperature	< Value from Map 1

Map 1

Engine coolant temperature at start °C (°F)	-40 (-40)	-30 (-22)	-20 (-4)	-10 (-14)	0 (32)	10 (50)	20 (68)	30 (86)	40 (104)	50 (122)
Threshold value AT model °C (°F)	152 (306)	152 (306)	152 (306)	152 (306)	152 (306)	143 (289)	135 (275)	127 (261)	121 (250)	118 (244)
Threshold value MT model °C (°F)	135 (275)	135 (275)	135 (275)	135 (275)	135 (275)	135 (275)	134 (273)	129 (264)	126 (259)	119 (246)

Time Needed for Diagnosis: 14 seconds

Malfunction indicator light: Illuminates when malfunction occurs in 2 continuous driving cycles.

Normality Judgement

Judge as OK when the following conditions are established after predetermined amount of time has passed.

Judgment Value

Malfunction Criteria	Threshold Value
Estimated exhaust temperature	≥ Value from Map 1

- Diagnosis of idle speed

Judges NG when all of the following conditions are established, and judge as OK if they are not established.

Malfunction Criteria	Threshold Value
Continuous time of (target engine RPM – engine RPM > 300)	≥ 10000 ms
(actual retard amount > AT model:18°C A, MT model:13°C A)	≥ 3000 ms

Time Needed for Diagnosis: 6 seconds

Malfunction Indicator Light Illumination: Illuminates when malfunction occurs in 2 continuous driving cycles.

5. DTC CLEAR CONDITION

- When the OK idling cycle is completed 40 times in a row
- When “Clear Memory” is performed

6. MALFUNCTION INDICATOR LIGHT CLEAR CONDITION

- When the OK driving cycle is completed 3 times in a row
- When “Clear Memory” is performed

7. FAIL SAFE

None

8. ECM OPERATION AT DTC SETTING

Memorize the freeze frame data. (For test mode \$02)

Diagnostic Trouble Code (DTC) Detecting Criteria

GENERAL DESCRIPTION

DE:DTC P2096 POST CATALYST FUEL TRIM SYSTEM TOO LEAN BANK 1

1. OUTLINE OF DIAGNOSIS

Detect the malfunction of fuel system from the amount of sub feedback control.

Judge as NG when the sub feedback learning control is being performed and when the learning value goes to the lean side.

2. COMPONENT DESCRIPTION

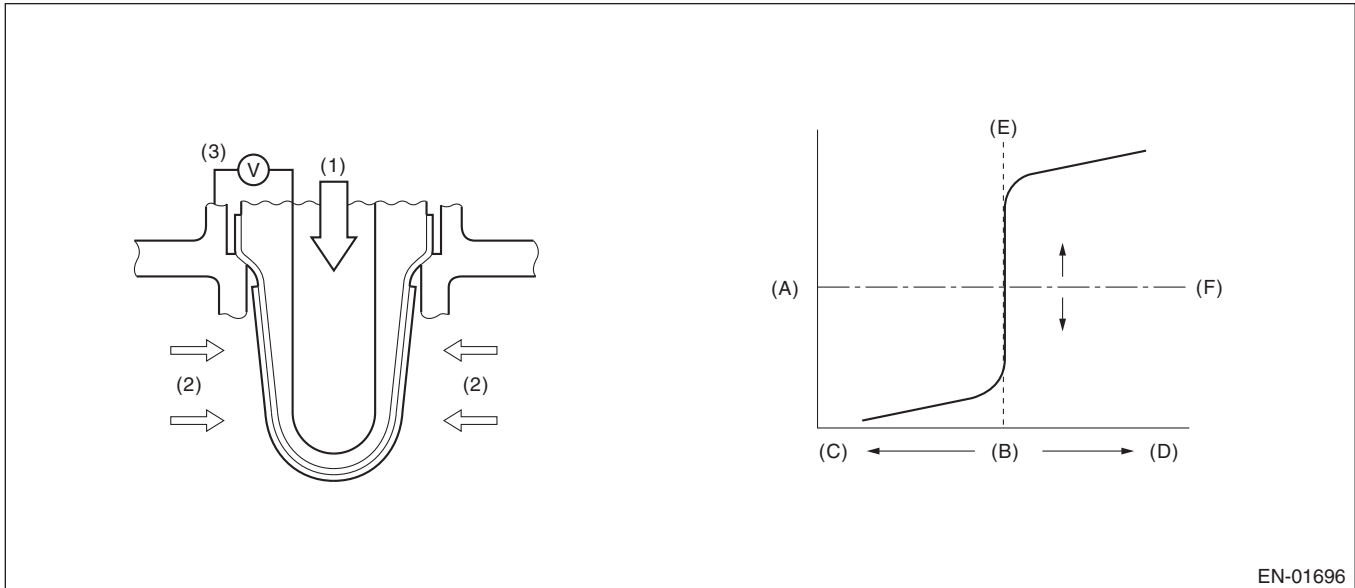

EN-01696

- (1) Atmosphere
- (2) Exhaust gas
- (3) Electromotive force

- (A) Electromotive force
- (B) Air fuel ratio
- (C) Rich

- (D) Lean
- (E) Theoretical air fuel ratio
- (F) Comparative voltage

3. ENABLE CONDITION

Secondary Parameters	Enable Conditions
Continuous time when the following conditions are established	1 second or more
Sub feedback learning execution conditions	Completed

4. GENERAL DRIVING CYCLE

Perform the diagnosis continuously at a constant speed of 50 — 100 km/h (31 — 62 MPH).

5. DIAGNOSTIC METHOD

Judge as NG when the continuous time of meeting the malfunction criteria below becomes 5 seconds or more. Judge as OK when the continuous time of not meeting the malfunction criteria below becomes 5 seconds or more.

Judgment Value

Malfunction Criteria	Threshold Value
Sub feedback learning value	≤ -0.02

Time Needed for Diagnosis: 5 seconds × 1 time

Malfunction Indicator Light Illumination: Illuminates when malfunction occurs in 2 continuous driving cycles.

Diagnostic Trouble Code (DTC) Detecting Criteria

GENERAL DESCRIPTION

6. DTC CLEAR CONDITION

- When the OK idling cycle is completed 40 times in a row
- When "Clear Memory" is performed

7. MALFUNCTION INDICATOR LIGHT CLEAR CONDITION

- When similar driving conditions are repeated 3 times and the result is OK.
- When "Clear Memory" is performed

8. FAIL SAFE

None

9. ECM OPERATION AT DTC SETTING

Memorize the freeze frame data. (For test mode \$02)

DF:DTC P2097 POST CATALYST FUEL TRIM SYSTEM TOO RICH BANK 1

1. OUTLINE OF DIAGNOSIS

Detect the malfunction of fuel system from the amount of sub feedback control.

Judge as NG when the sub feedback learning control is being performed and when the learning value goes to the rich side.

2. COMPONENT DESCRIPTION

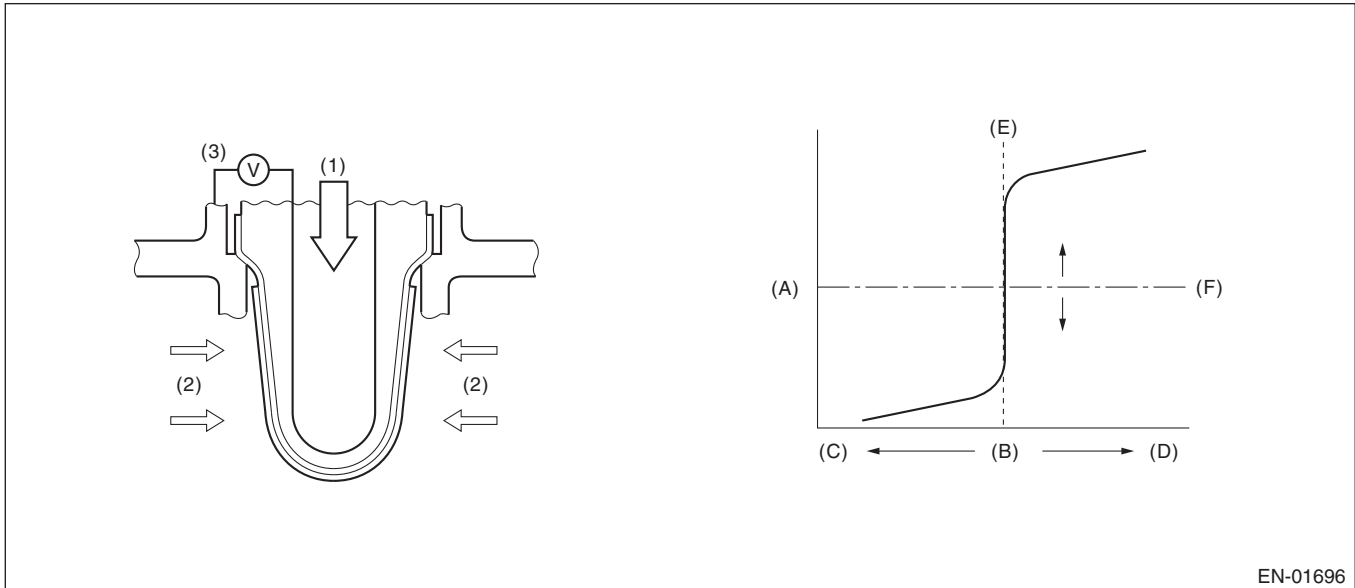

EN-01696

- | | | |
|-------------------------|-------------------------|--------------------------------|
| (1) Atmosphere | (A) Electromotive force | (D) Lean |
| (2) Exhaust gas | (B) Air fuel ratio | (E) Theoretical air fuel ratio |
| (3) Electromotive force | (C) Rich | (F) Comparative voltage |

3. ENABLE CONDITION

Secondary Parameters	Enable Conditions
Continuous time when the following conditions are established	1 second or more
Sub feedback learning execution conditions	Completed

4. GENERAL DRIVING CYCLE

Perform the diagnosis continuously at a constant speed of 50 — 100 km/h (31 — 62 MPH).

5. DIAGNOSTIC METHOD

Judge as NG when the continuous time of meeting the malfunction criteria below becomes 5 seconds or more. Judge as OK when the continuous time of not meeting the malfunction criteria below becomes 5 seconds or more.

Judgment Value

Malfunction Criteria	Threshold Value
Sub feedback learning value	≥ 0.038

Time Needed for Diagnosis: 5 seconds × 1 time

Malfunction Indicator Light Illumination: Illuminates when malfunction occurs in 2 continuous driving cycles.

Diagnostic Trouble Code (DTC) Detecting Criteria

GENERAL DESCRIPTION

6. DTC CLEAR CONDITION

- When the OK idling cycle is completed 40 times in a row
- When "Clear Memory" is performed

7. MALFUNCTION INDICATOR LIGHT CLEAR CONDITION

- When similar driving conditions are repeated 3 times and the result is OK.
- When "Clear Memory" is performed

8. FAIL SAFE

None

9. ECM OPERATION AT DTC SETTING

Memorize the freeze frame data. (For test mode \$02)

DG:DTC P2101 THROTTLE ACTUATOR CONTROL MOTOR CIRCUIT RANGE/ PERFORMANCE

1. OUTLINE OF DIAGNOSIS

Judge as NG when the motor current becomes too large or drive circuit is heated.

2. COMPONENT DESCRIPTION

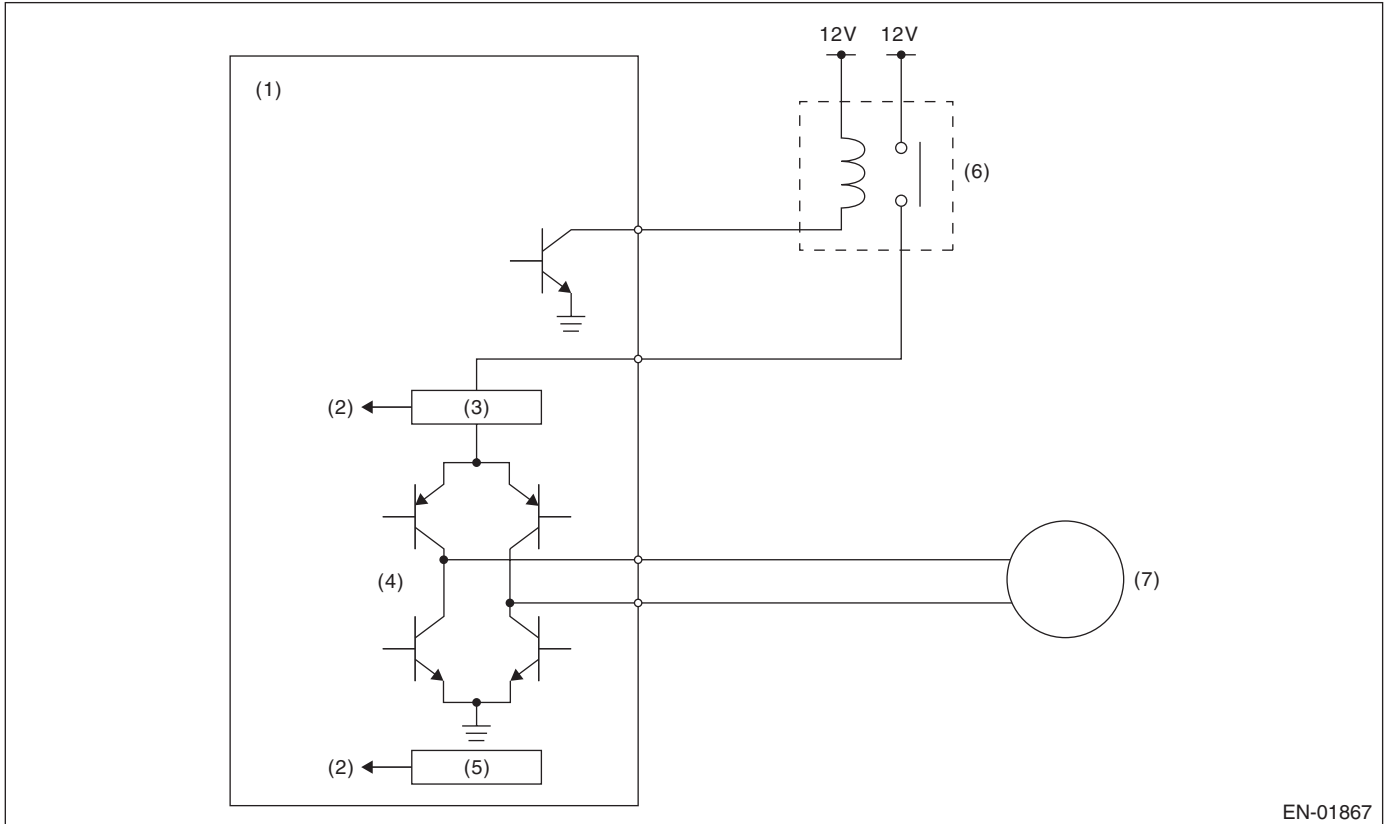

EN-01867

- | | | |
|-----------------------------------|-----------------------------------|---------------------------------------|
| (1) Engine control module (ECM) | (4) Drive circuit | (6) Electronic throttle control relay |
| (2) Detecting circuit | (5) Temperature detection circuit | (7) Motor |
| (3) Overcurrent detection circuit | | |

3. ENABLE CONDITION

Secondary Parameters	Enable Conditions
Under control of electronic throttle control	ON

4. GENERAL DRIVING CYCLE

Always perform the diagnosis continuously.

Diagnostic Trouble Code (DTC) Detecting Criteria

GENERAL DESCRIPTION

5. DIAGNOSTIC METHOD

Judge as OK and clear the NG when the malfunction criteria below are met.

Judgment Value

Malfunction Criteria	Threshold Value
Motor current	≤ 8 A
Drive circuit inner temperature	$\leq 175^{\circ}\text{C}$ (347°F)

Time Needed for Diagnosis:

- 500 milliseconds (For NG)
- 2000 milliseconds (For OK)

Malfunction Indicator Light Illumination: Illuminates as soon as a malfunction occurs.

6. DTC CLEAR CONDITION

- When the OK idling cycle is completed 40 times in a row
- When "Clear Memory" is performed (Only with engine stopped)

7. MALFUNCTION INDICATOR LIGHT CLEAR CONDITION

- When the OK driving cycle is completed 3 times in a row
- When "Clear Memory" is performed (Only with engine stopped)

8. FAIL SAFE

Stop the continuity to the electronic throttle control motor. (Throttle opening is fixed to 6°.)

9. ECM OPERATION AT DTC SETTING

Memorize the freeze frame data. (For test mode \$02)

DH:DTC P2102 THROTTLE ACTUATOR CONTROL MOTOR CIRCUIT LOW

1. OUTLINE OF DIAGNOSIS

Judge as NG when the electronic throttle control power is not supplied even when ECM sets the electronic throttle control relay to ON.

2. COMPONENT DESCRIPTION

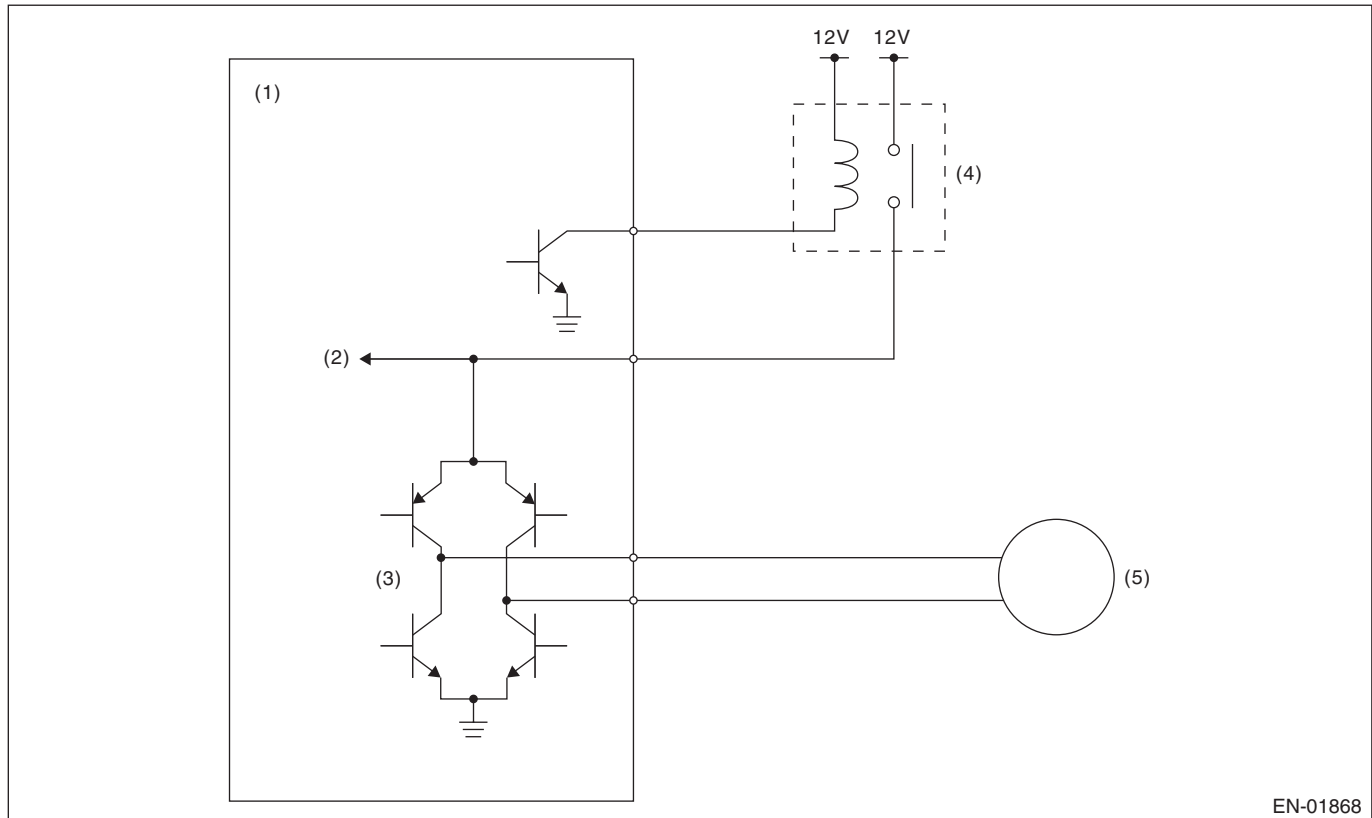

EN-01868

- | | | |
|---------------------------------|---------------------------------------|-----------|
| (1) Engine control module (ECM) | (3) Drive circuit | (5) Motor |
| (2) Voltage detection circuit | (4) Electronic throttle control relay | |

3. ENABLE CONDITION

Secondary Parameters	Enable Conditions
Electronic throttle control relay output	ON

4. GENERAL DRIVING CYCLE

Always perform the diagnosis continuously.

5. DIAGNOSTIC METHOD

Judge as OK and clear the NG when the malfunction criteria below are met.

Judgment Value

Malfunction Criteria	Threshold Value
Motor power voltage	≥ 5 V

Time Needed for Diagnosis:

- 400 milliseconds (For NG)
- 2000 milliseconds (For OK)

Malfunction Indicator Light Illumination: Illuminates as soon as a malfunction occurs.

Diagnostic Trouble Code (DTC) Detecting Criteria

GENERAL DESCRIPTION

6. DTC CLEAR CONDITION

- When the OK idling cycle is completed 40 times in a row
- When "Clear Memory" is performed (Only with engine stopped)

7. MALFUNCTION INDICATOR LIGHT CLEAR CONDITION

- When the OK driving cycle is completed 3 times in a row
- When "Clear Memory" is performed (Only with engine stopped)

8. FAIL SAFE

Stop the continuity to the electronic throttle control motor. (Throttle opening is fixed to 6°.)

9. ECM OPERATION AT DTC SETTING

Memorize the freeze frame data. (For test mode \$02)

DI: DTC P2103 THROTTLE ACTUATOR CONTROL MOTOR CIRCUIT HIGH

1. OUTLINE OF DIAGNOSIS

Judge as NG when the electronic throttle control power is supplied even when ECM sets the electronic throttle relay to OFF.

2. COMPONENT DESCRIPTION

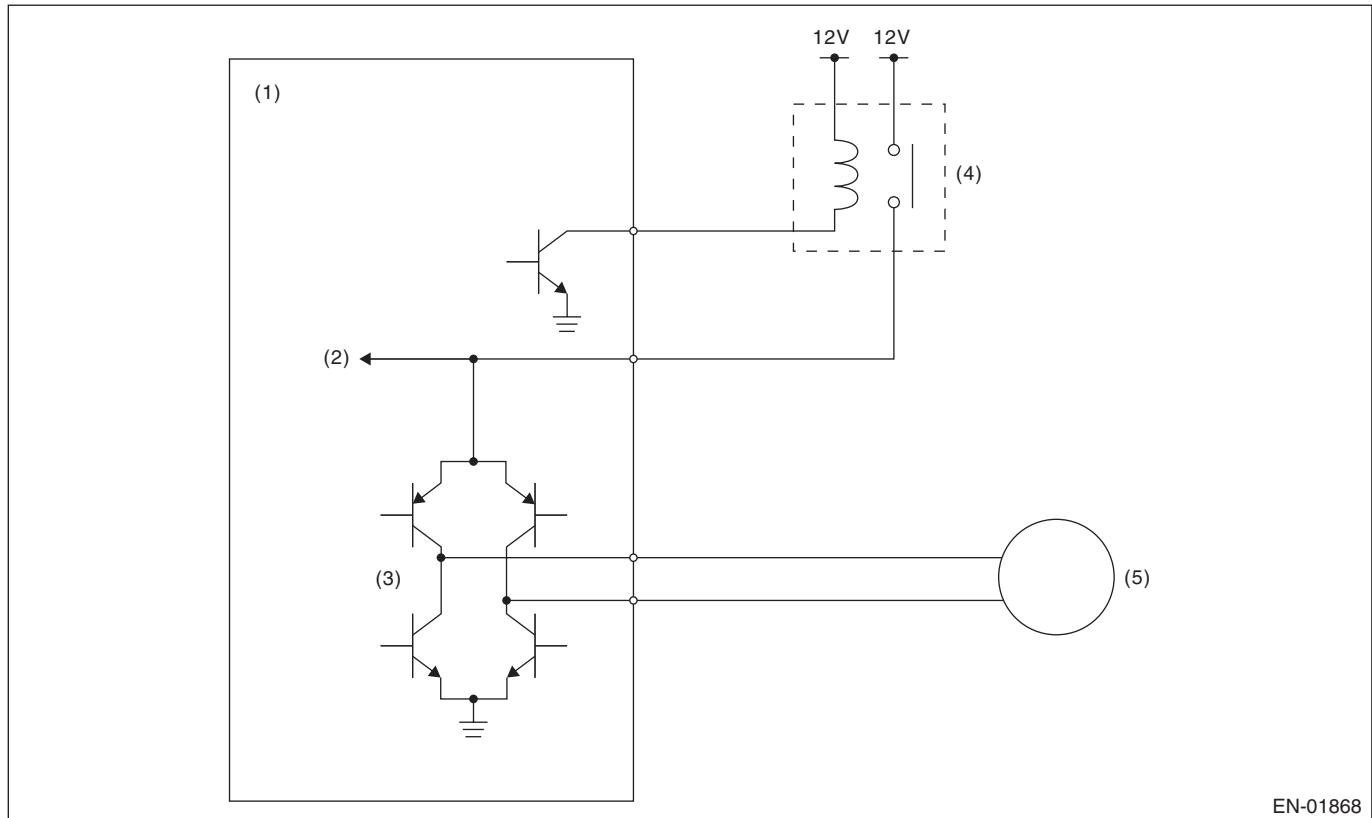

EN-01868

- | | | |
|---------------------------------|---------------------------------------|-----------|
| (1) Engine control module (ECM) | (3) Drive circuit | (5) Motor |
| (2) Voltage detection circuit | (4) Electronic throttle control relay | |

3. ENABLE CONDITION

Secondary Parameters	Enable Conditions
Electronic throttle control relay output	OFF

4. GENERAL DRIVING CYCLE

- When ignition switch ON → OFF
- Ignition switch OFF → ON (Only after clearing memory)

5. DIAGNOSTIC METHOD

Judge as OK and clear the NG when the malfunction criteria below are met.

Judgment Value

Malfunction Criteria	Threshold Value
Motor power voltage	≤ 5 V

Time Needed for Diagnosis:

- 600 milliseconds (For NG)
- 400 milliseconds (For OK)

Malfunction Indicator Light Illumination: Illuminates as soon as a malfunction occurs.

Diagnostic Trouble Code (DTC) Detecting Criteria

GENERAL DESCRIPTION

6. DTC CLEAR CONDITION

- When the OK idling cycle is completed 40 times in a row
- When “Clear Memory” is performed (Only with engine stopped)

7. MALFUNCTION INDICATOR LIGHT CLEAR CONDITION

- When the OK driving cycle is completed 3 times in a row
- When “Clear Memory” is performed (Only with engine stopped)

8. FAIL SAFE

Stop the continuity to the electronic throttle control motor. (Throttle opening is fixed to 6°.)

9. ECM OPERATION AT DTC SETTING

Memorize the freeze frame data. (For test mode \$02)

DJ:DTC P2109 THROTTLE/PEDAL POSITION SENSOR “A” MINIMUM STOP PERFORMANCE

1. OUTLINE OF DIAGNOSIS

Judge as NG when all close point learning cannot conducted or abnormal value is detected.

2. COMPONENT DESCRIPTION

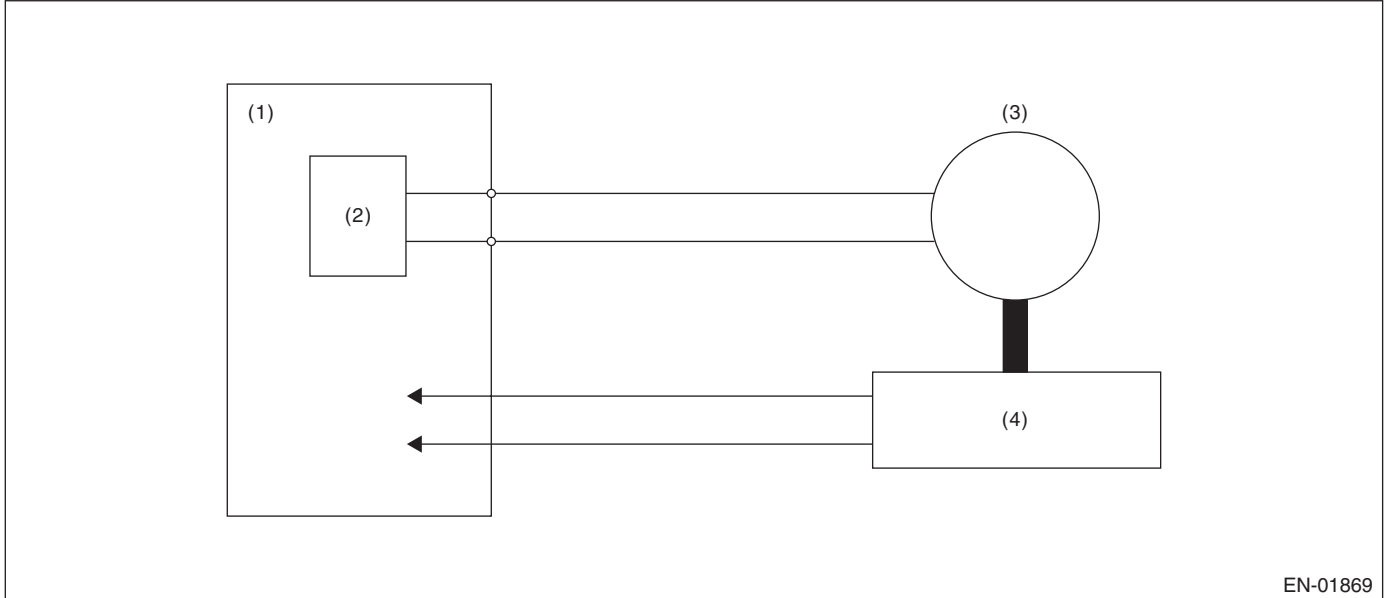

- | | |
|---------------------------------|------------------------------|
| (1) Engine control module (ECM) | (3) Motor |
| (2) Drive circuit | (4) Throttle position sensor |

3. ENABLE CONDITION

Secondary Parameters	Enable Conditions
Ignition switch	ON → OFF
Ignition switch (only after cleaning the memory)	OFF → ON

4. GENERAL DRIVING CYCLE

Perform the diagnosis at all close point learning.

5. DIAGNOSTIC METHOD

Judge as OK and clear the NG when the malfunction criteria below are met.

Judgment Value

Malfunction Criteria	Threshold Value
Throttle opening angle at all close point learning	10.127° or more, 19.872° or less
Throttle sensor opening angle when the ignition switch is ON – Throttle minimum stop position	≥ 1.683°

Time Needed for Diagnosis: 8 — 80 milliseconds

Malfunction Indicator Light Illumination: Illuminates as soon as a malfunction occurs.

6. DTC CLEAR CONDITION

- When the OK idling cycle is completed 40 times in a row
- When “Clear Memory” is performed (Only with engine stopped)

Diagnostic Trouble Code (DTC) Detecting Criteria

GENERAL DESCRIPTION

7. MALFUNCTION INDICATOR LIGHT CLEAR CONDITION

- When the OK driving cycle is completed 3 times in a row
- When "Clear Memory" is performed (Only with engine stopped)

8. FAIL SAFE

Stop the continuity to the electronic throttle control motor. (Throttle opening is fixed to 6°.)

9. ECM OPERATION AT DTC SETTING

Memorize the freeze frame data. (For test mode \$02)

DK:DTC P2122 THROTTLE/PEDAL POSITION SENSOR/SWITCH “D” CIRCUIT LOW INPUT

1. OUTLINE OF DIAGNOSIS

Detect the open or short circuit of accelerator pedal position sensor 1.

Judge as NG if it is out of specification.

2. COMPONENT DESCRIPTION

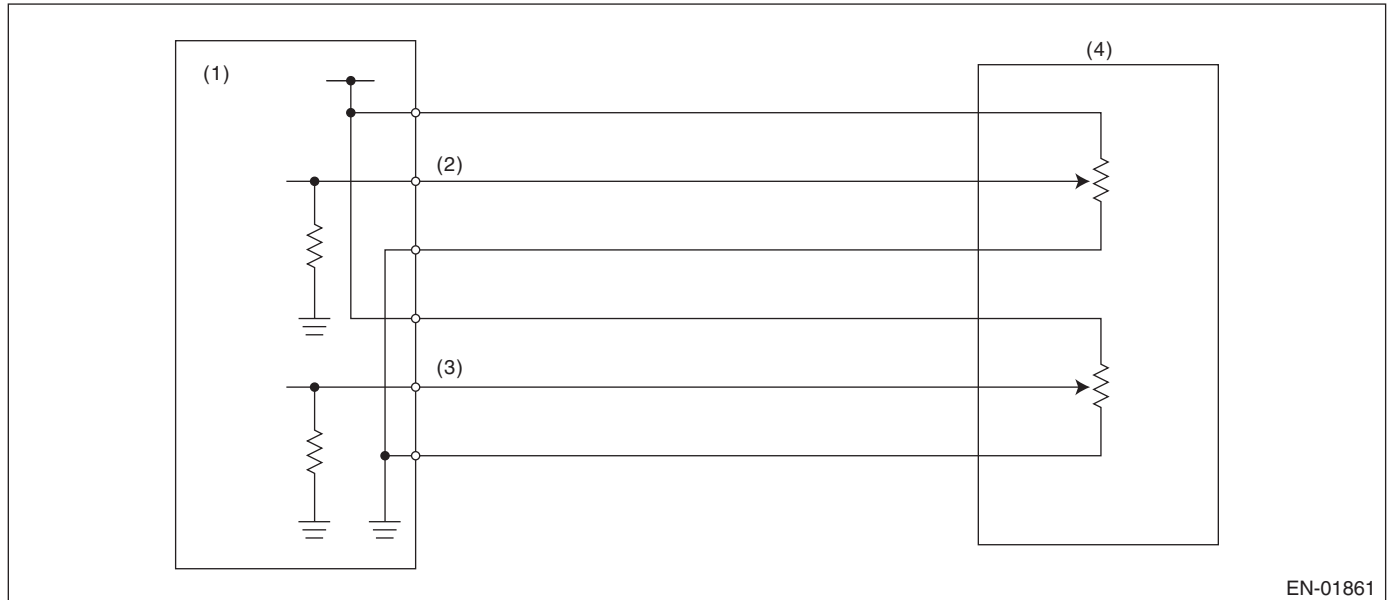

- | | | |
|--|--|---------------------------------------|
| (1) Engine control module (ECM) | (3) Accelerator pedal position sensor 2 signal | (4) Accelerator pedal position sensor |
| (2) Accelerator pedal position sensor 1 signal | | |

3. ENABLE CONDITION

Secondary Parameters	Enable Conditions
Ignition switch	ON

4. GENERAL DRIVING CYCLE

Always perform the diagnosis continuously.

5. DIAGNOSTIC METHOD

Judge as OK and clear the NG when the malfunction criteria below are met.

Judgment Value

Malfunction Criteria	Threshold Value
Sensor 1 input voltage	≥ 0.308 V

Time Needed for Diagnosis: 100 milliseconds

Malfunction Indicator Light Illumination: Illuminates as soon as a malfunction occurs.

6. DTC CLEAR CONDITION

- When the OK idling cycle is completed 40 times in a row
- When “Clear Memory” is performed (Only with engine stopped)

7. MALFUNCTION INDICATOR LIGHT CLEAR CONDITION

- When the OK driving cycle is completed 3 times in a row
- When “Clear Memory” is performed (Only with engine stopped)

Diagnostic Trouble Code (DTC) Detecting Criteria

GENERAL DESCRIPTION

8. FAIL SAFE

- Single malfunction: Control with normal sensor
- Simultaneous failure: Throttle opening is fixed to 6°.

9. ECM OPERATION AT DTC SETTING

Memorize the freeze frame data. (For test mode \$02)

DL:DTC P2123 THROTTLE/PEDAL POSITION SENSOR/SWITCH “D” CIRCUIT HIGH INPUT

1. OUTLINE OF DIAGNOSIS

Detect the open or short circuit of accelerator pedal position sensor 1.

Judge as NG if it is out of specification.

2. COMPONENT DESCRIPTION

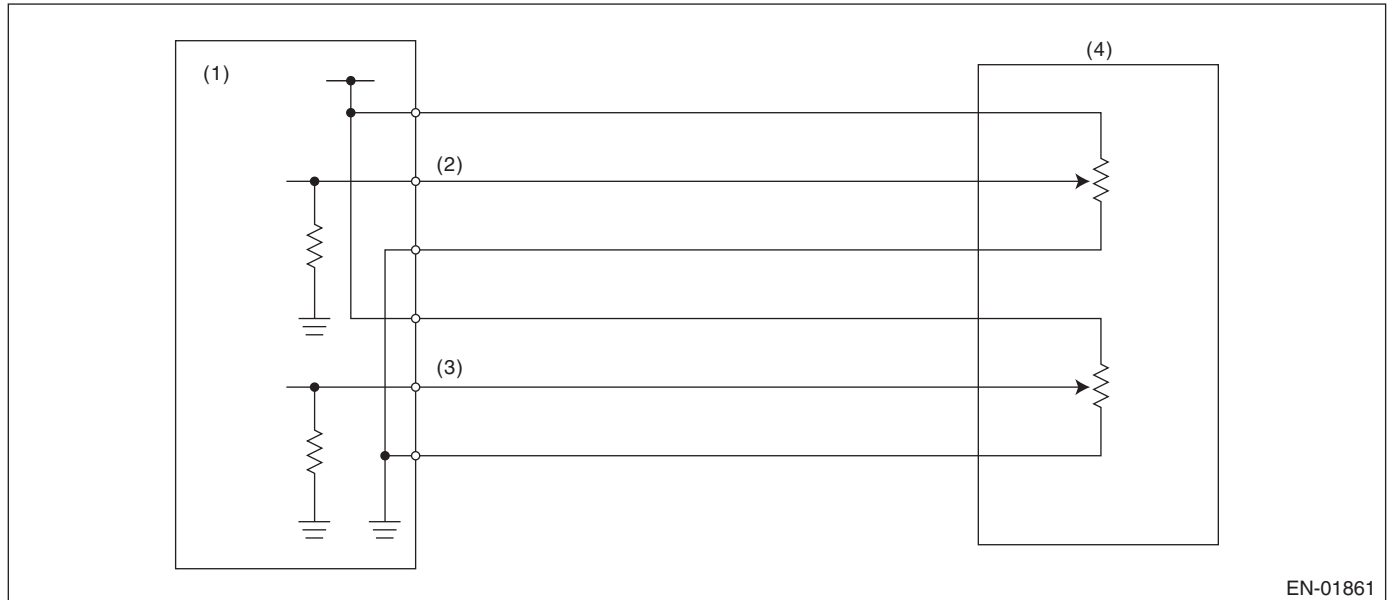

- | | | |
|--|--|---------------------------------------|
| (1) Engine control module (ECM) | (3) Accelerator pedal position sensor 2 signal | (4) Accelerator pedal position sensor |
| (2) Accelerator pedal position sensor 1 signal | | |

3. ENABLE CONDITION

Secondary Parameters	Enable Conditions
Ignition switch	ON

4. GENERAL DRIVING CYCLE

Always perform the diagnosis continuously.

5. DIAGNOSTIC METHOD

Judge as OK and clear the NG when the malfunction criteria below are met.

Judgment Value

Malfunction Criteria	Threshold Value
Sensor 1 input voltage	$\leq 4.856 \text{ V}$

Time Needed for Diagnosis: 100 milliseconds

Malfunction Indicator Light Illumination: Illuminates as soon as a malfunction occurs.

6. DTC CLEAR CONDITION

- When the OK idling cycle is completed 40 times in a row
- When “Clear Memory” is performed (Only with engine stopped)

7. MALFUNCTION INDICATOR LIGHT CLEAR CONDITION

- When the OK driving cycle is completed 3 times in a row
- When “Clear Memory” is performed (Only with engine stopped)

Diagnostic Trouble Code (DTC) Detecting Criteria

GENERAL DESCRIPTION

8. FAIL SAFE

- Single malfunction: Control with normal sensor
- Simultaneous failure: Throttle opening is fixed to 6°.

9. ECM OPERATION AT DTC SETTING

Memorize the freeze frame data. (For test mode \$02)

DM:DTC P2127 THROTTLE/PEDAL POSITION SENSOR/SWITCH “E” CIRCUIT LOW INPUT

1. OUTLINE OF DIAGNOSIS

Detect the open or short circuit of accelerator pedal position sensor 2.

Judge as NG if it is out of specification.

2. COMPONENT DESCRIPTION

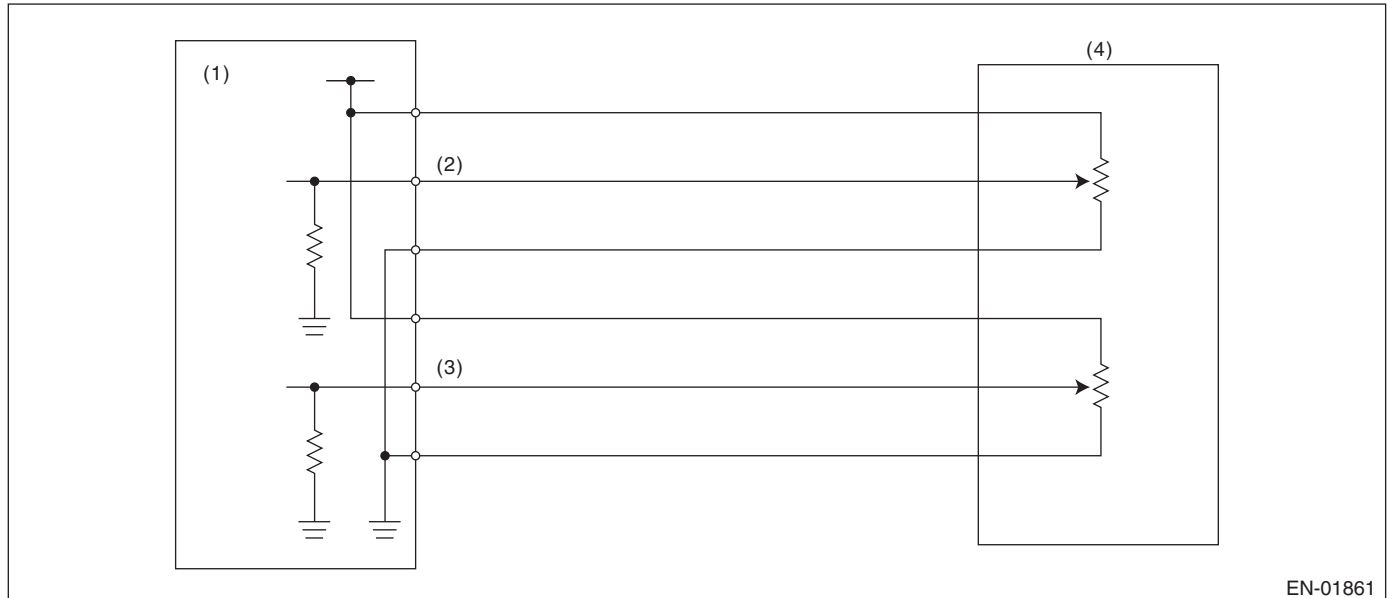

- | | | |
|--|--|---------------------------------------|
| (1) Engine control module (ECM) | (3) Accelerator pedal position sensor 2 signal | (4) Accelerator pedal position sensor |
| (2) Accelerator pedal position sensor 1 signal | | |

3. ENABLE CONDITION

Secondary Parameters	Enable Conditions
Ignition switch	ON

4. GENERAL DRIVING CYCLE

Always perform the diagnosis continuously.

5. DIAGNOSTIC METHOD

Judge as OK and clear the NG when the malfunction criteria below are met.

Judgment Value

Malfunction Criteria	Threshold Value
Sensor 2 input voltage	$\geq 0.308 \text{ V}$

Time Needed for Diagnosis: 100 milliseconds

Malfunction Indicator Light Illumination: Illuminates as soon as a malfunction occurs.

6. DTC CLEAR CONDITION

- When the OK idling cycle is completed 40 times in a row
- When “Clear Memory” is performed (Only with engine stopped)

7. MALFUNCTION INDICATOR LIGHT CLEAR CONDITION

- When the OK driving cycle is completed 3 times in a row
- When “Clear Memory” is performed (Only with engine stopped)

Diagnostic Trouble Code (DTC) Detecting Criteria

GENERAL DESCRIPTION

8. FAIL SAFE

- Single malfunction: Control with normal sensor
- Simultaneous failure: Throttle opening is fixed to 6°.

9. ECM OPERATION AT DTC SETTING

Memorize the freeze frame data. (For test mode \$02)

DN:DTC P2128 THROTTLE/PEDAL POSITION SENSOR/SWITCH “E” CIRCUIT HIGH INPUT

1. OUTLINE OF DIAGNOSIS

Detect the open or short circuit of accelerator pedal position sensor 2.

Judge as NG if it is out of specification.

2. COMPONENT DESCRIPTION

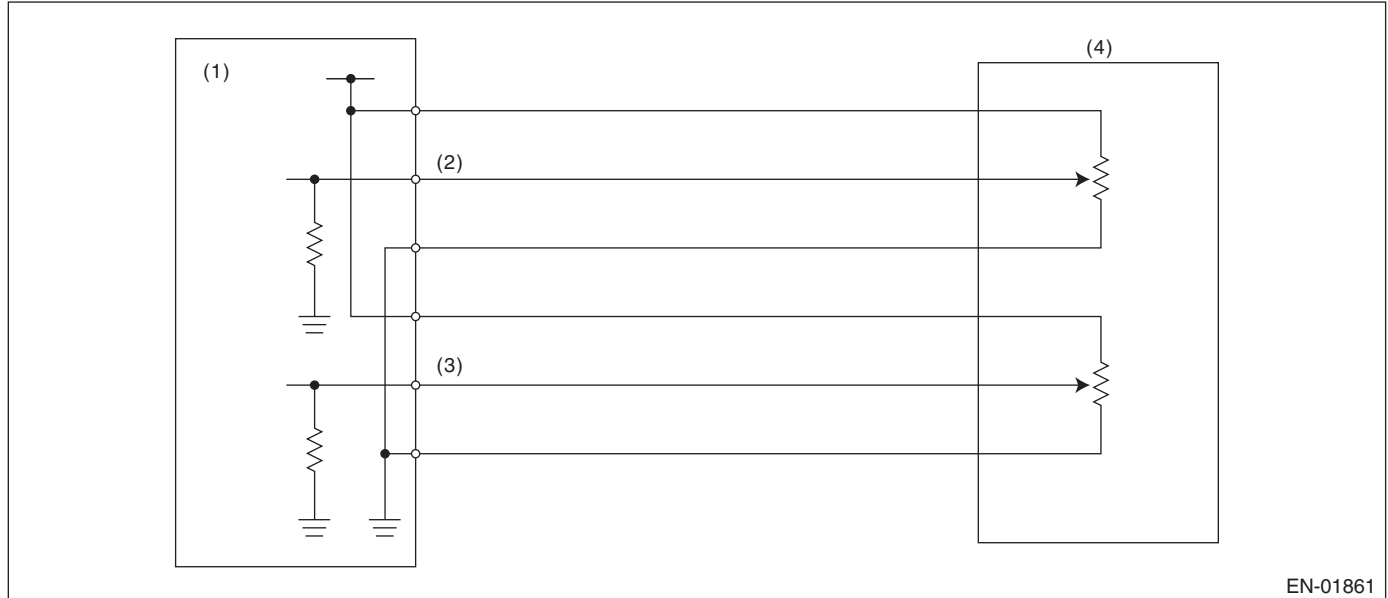

- | | | |
|--|--|---------------------------------------|
| (1) Engine control module (ECM) | (3) Accelerator pedal position sensor 2 signal | (4) Accelerator pedal position sensor |
| (2) Accelerator pedal position sensor 1 signal | | |

3. ENABLE CONDITION

Secondary Parameters	Enable Conditions
Ignition switch	ON

4. GENERAL DRIVING CYCLE

Always perform the diagnosis continuously.

5. DIAGNOSTIC METHOD

Judge as OK and clear the NG when the malfunction criteria below are met.

Judgment Value

Malfunction Criteria	Threshold Value
Sensor 2 input voltage	$\leq 4.865 \text{ V}$

Time Needed for Diagnosis: 100 milliseconds

Malfunction Indicator Light Illumination: Illuminates as soon as a malfunction occurs.

6. DTC CLEAR CONDITION

- When the OK idling cycle is completed 40 times in a row
- When “Clear Memory” is performed (Only with engine stopped)

7. MALFUNCTION INDICATOR LIGHT CLEAR CONDITION

- When the OK driving cycle is completed 3 times in a row
- When “Clear Memory” is performed (Only with engine stopped)

Diagnostic Trouble Code (DTC) Detecting Criteria

GENERAL DESCRIPTION

8. FAIL SAFE

- Single malfunction: Control with normal sensor
- Simultaneous failure: Throttle opening is fixed to 6°.

9. ECM OPERATION AT DTC SETTING

Memorize the freeze frame data. (For test mode \$02)

Diagnostic Trouble Code (DTC) Detecting Criteria

GENERAL DESCRIPTION

DO:DTC P2135 THROTTLE/PEDAL POSITION SENSOR/SWITCH "A"/"B" VOLTAGE CORRELATION

1. OUTLINE OF DIAGNOSIS

Judge as NG when the signal level of throttle position sensor 1 is different from the throttle position sensor 2.

2. COMPONENT DESCRIPTION

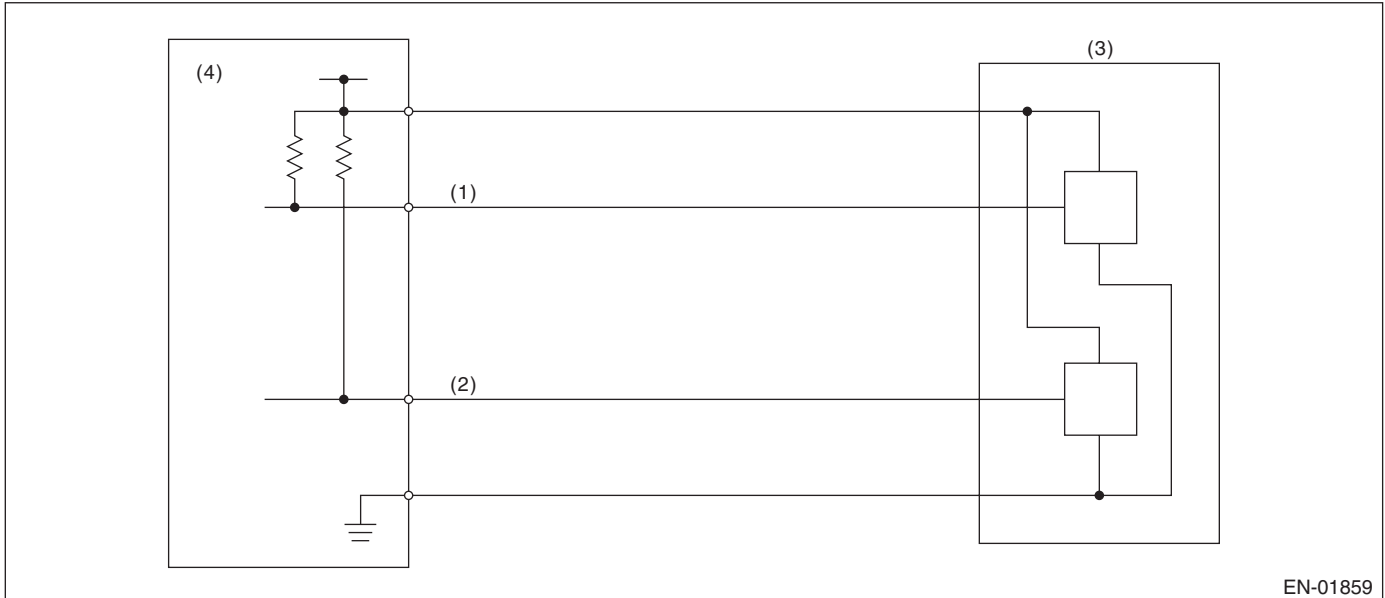

- (1) Throttle position sensor 1 signal
- (2) Throttle position sensor 2 signal
- (3) Throttle position sensor
- (4) Engine control module (ECM)

3. ENABLE CONDITION

Secondary Parameters	Enable Conditions
Ignition switch	ON

4. GENERAL DRIVING CYCLE

Always perform the diagnosis continuously.

Diagnostic Trouble Code (DTC) Detecting Criteria

GENERAL DESCRIPTION

5. DIAGNOSTIC METHOD

Judge as OK and clear the NG when the malfunction criteria below are met.

Judgment Value

Malfunction Criteria	Threshold Value
Signal difference between two sensors	$\leq 4.5^\circ$

Details of Judgment Value

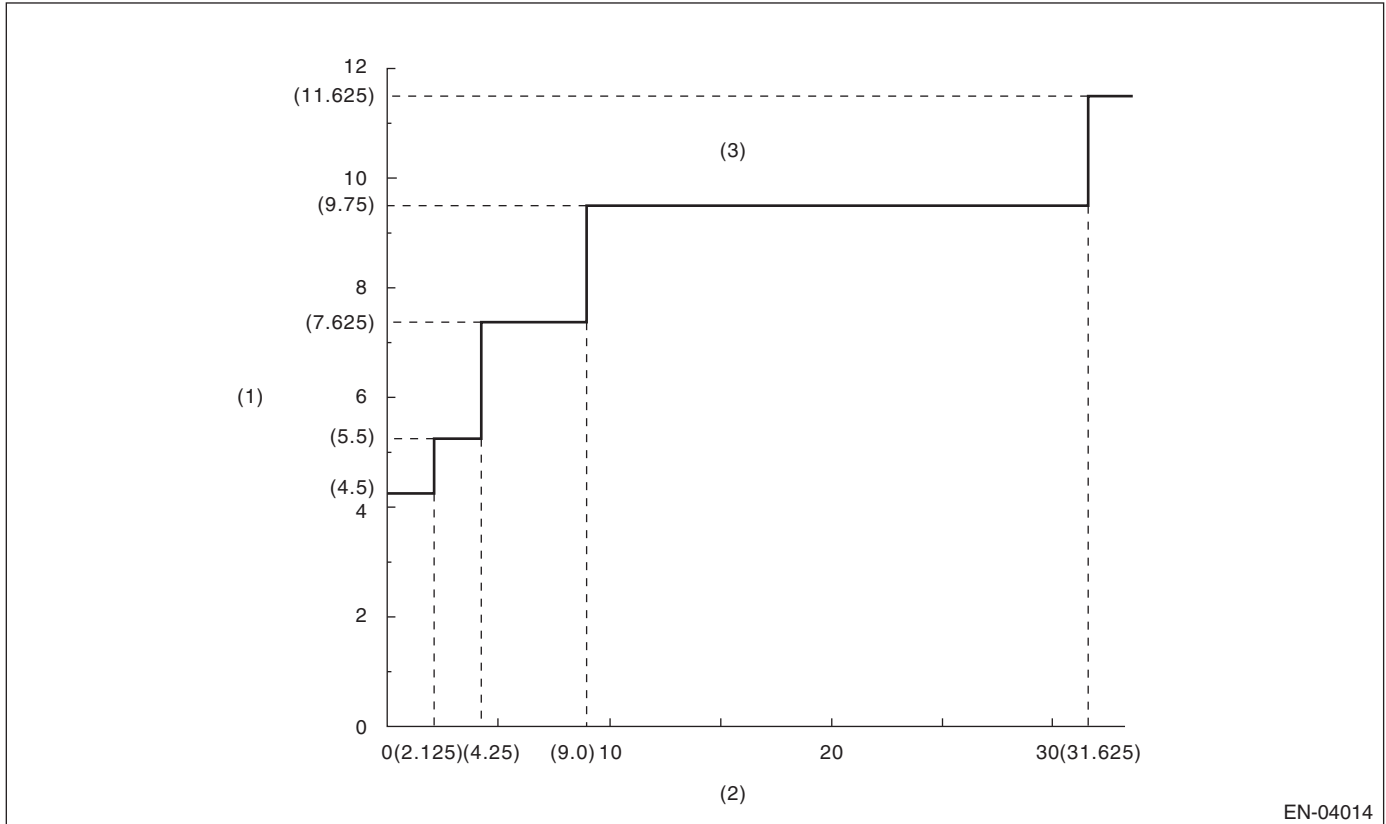

(1) Sensor output difference ($^\circ$)

(2) Throttle position sensor 1 opening angle ($^\circ$)

(3) NG area

Time Needed for Diagnosis: 24 milliseconds (For NG), 24 milliseconds (For OK)

Malfunction Indicator Light Illumination: Illuminates as soon as a malfunction occurs.

6. DTC CLEAR CONDITION

- When the OK idling cycle is completed 40 times in a row
- When "Clear Memory" is performed (Only with engine stopped)

7. MALFUNCTION INDICATOR LIGHT CLEAR CONDITION

- When the OK driving cycle is completed 3 times in a row
- When "Clear Memory" is performed (Only with engine stopped)

8. FAIL SAFE

Stop the continuity to the electronic throttle control motor. (Throttle opening is fixed to 6° .)

9. ECM OPERATION AT DTC SETTING

Memorize the freeze frame data. (For test mode \$02)

Diagnostic Trouble Code (DTC) Detecting Criteria

GENERAL DESCRIPTION

DP:DTC P2138 THROTTLE/PEDAL POSITION SENSOR/SWITCH “D”/“E” VOLT-AGE CORRELATION

1. OUTLINE OF DIAGNOSIS

Judge as NG when the signal level of accelerator pedal position sensor 1 is different from the accelerator pedal position sensor 2.

2. COMPONENT DESCRIPTION

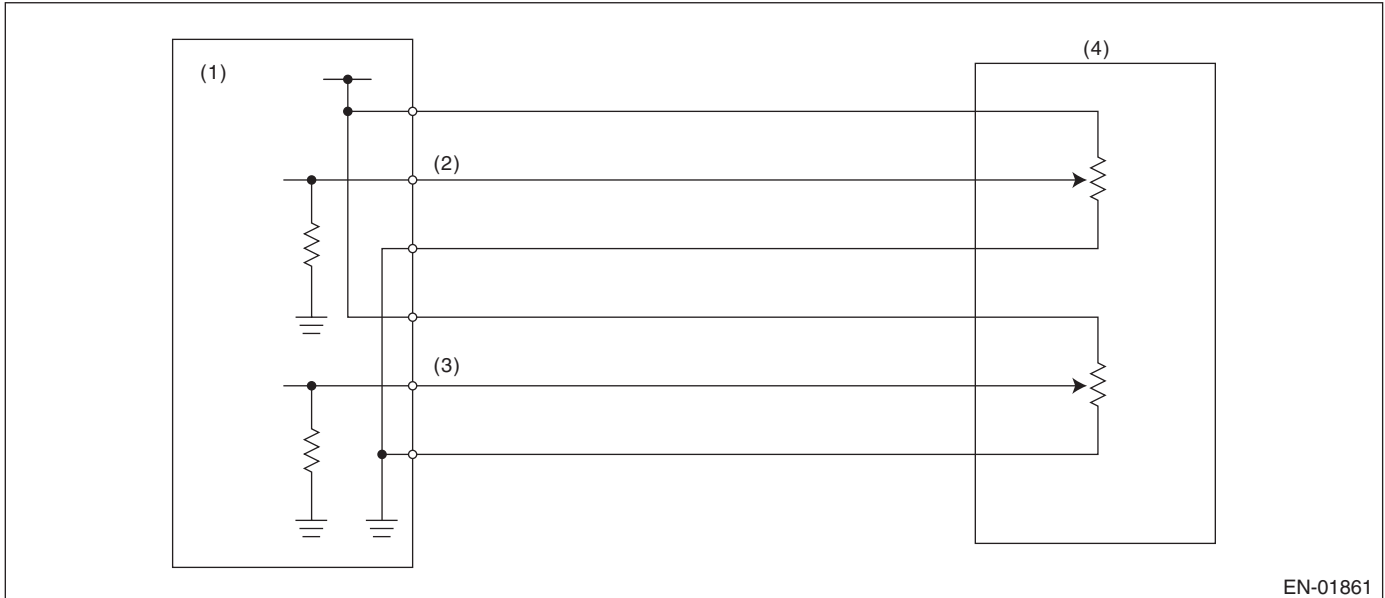

EN-01861

- (1) Engine control module (ECM) (3) Accelerator pedal position sensor 2 signal (4) Accelerator pedal position sensor 2 signal
(2) Accelerator pedal position sensor 1 signal

3. ENABLE CONDITION

Secondary Parameters	Enable Conditions
Ignition switch	ON
Battery voltage	≥ 6 (V)

4. GENERAL DRIVING CYCLE

Always perform the diagnosis continuously.

Diagnostic Trouble Code (DTC) Detecting Criteria

GENERAL DESCRIPTION

5. DIAGNOSTIC METHOD

Judge as OK and clear the NG when the malfunction criteria below are met.

Judgment Value

Malfunction Criteria	Threshold Value
Signal difference between two sensors	$\leq 1.465^\circ$

Details of Judgment Value

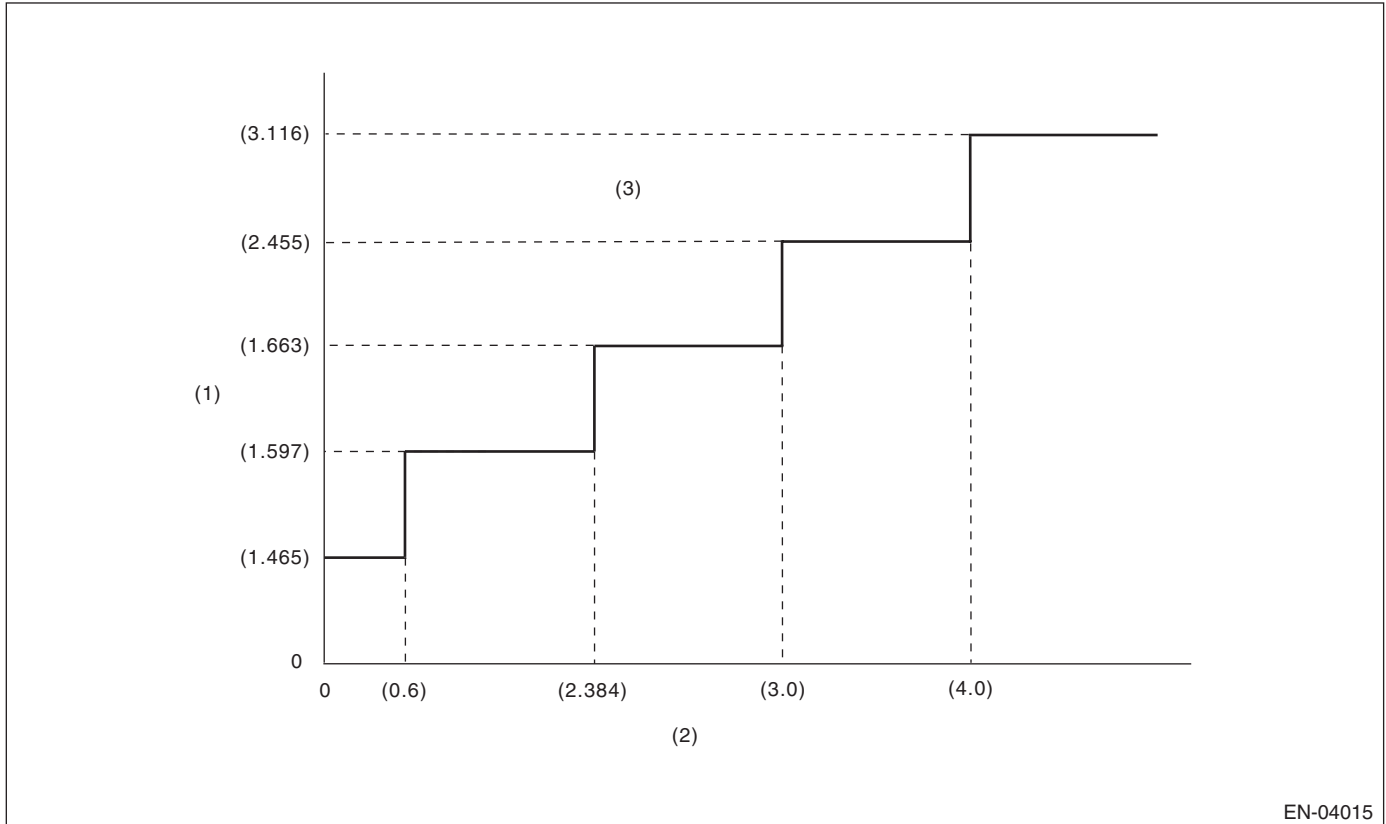

(1) Sensor output difference ($^\circ$)

(2) Throttle position sensor 2 opening angle ($^\circ$)

(3) NG area

Time Needed for Diagnosis:

- 116 milliseconds (For NG)
- 1000 milliseconds (For OK)

Malfunction Indicator Light Illumination: Illuminates as soon as a malfunction occurs.

6. DTC CLEAR CONDITION

- When the OK idling cycle is completed 40 times in a row
- When "Clear Memory" is performed

7. MALFUNCTION INDICATOR LIGHT CLEAR CONDITION

- When the OK driving cycle is completed 3 times in a row
- When "Clear Memory" is performed

8. FAIL SAFE

Throttle opening is fixed to 6° .

9. ECM OPERATION AT DTC SETTING

Memorize the freeze frame data. (For test mode \$02)

Diagnostic Trouble Code (DTC) Detecting Criteria

GENERAL DESCRIPTION

DQ:DTC P2227 BAROMETRIC PRESSURE CIRCUIT RANGE/PERFORMANCE

1. OUTLINE OF DIAGNOSIS

Detect the malfunction of atmospheric pressure sensor output property.

Judge as NG when the atmospheric pressure sensor output is largely different from the intake manifold pressure at engine starting.

2. COMPONENT DESCRIPTION

The atmospheric pressure sensor is built into the ECM.

3. ENABLE CONDITION

Secondary Parameters	Enable Conditions
Engine speed	< 300 rpm
Vehicle speed	< 1 km/h (1 MPH)

4. GENERAL DRIVING CYCLE

Perform the diagnosis before engine starts with the ignition switch ON.

5. DIAGNOSTIC METHOD

Abnormality Judgment

Judge as NG when the continuous time of meeting the malfunction criteria below becomes 0.3 seconds or more.

Judgment Value

Malfunction Criteria	Threshold Value
Atmospheric pressure – Manifold pressure	≥ 26.7 kPa (200 mmHg, 7.88 inHg)
Intake manifold pressure at engine startup – Manifold pressure	< 1.33 kPa (10 mmHg, 2.95 inHg)

Time Needed for Diagnosis: 0.3 seconds

Malfunction Indicator Light Illumination: Illuminates when malfunction occurs in 2 continuous driving cycles.

Normality Judgment

Judge as OK and clear the NG when the continuous time with the following criteria established is more than 0.3 seconds.

Judgment Value

Malfunction Criteria	Threshold Value
Atmospheric pressure – Manifold pressure	< 26.7 kPa (200 mmHg, 7.88 inHg)

6. DTC CLEAR CONDITION

- When the OK idling cycle is completed 40 times in a row
- When “Clear Memory” is performed

7. MALFUNCTION INDICATOR LIGHT CLEAR CONDITION

- When the OK driving cycle is completed 3 times in a row
- When “Clear Memory” is performed

8. FAIL SAFE

Atmospheric pressure sensor process: Fix the atmospheric pressure to 101 kPa (760 mmHg, 29.8 inHg).

9. ECM OPERATION AT DTC SETTING

Memorize the freeze frame data. (For test mode \$02)

Diagnostic Trouble Code (DTC) Detecting Criteria

GENERAL DESCRIPTION

DR:DTC P2228 BAROMETRIC PRESSURE CIRCUIT LOW

1. OUTLINE OF DIAGNOSIS

Detect the open/short circuit of the atmospheric pressure sensor.
Judge as NG if it is out of specification.

2. COMPONENT DESCRIPTION

The atmospheric pressure sensor is built into the ECM.

3. ENABLE CONDITION

Secondary Parameters	Enable Conditions
None	

4. GENERAL DRIVING CYCLE

Always perform the diagnosis continuously.

5. DIAGNOSTIC METHOD

Abnormality Judgment

Judge as NG when the continuous time of meeting the malfunction criteria below becomes 0.5 seconds or more.

Judgment Value

Malfunction Criteria	Threshold Value
Ignition switch	ON
Output voltage	< 0.118 V

Time Needed for Diagnosis: 0.5 seconds

Malfunction Indicator Light Illumination: Illuminates as soon as a malfunction occurs.

Normality Judgment

Judge as OK and clear the NG when the malfunction criteria below are met.

Judgment Value

Malfunction Criteria	Threshold Value
Ignition switch	ON
Output voltage	≥ 0.118 V

6. DTC CLEAR CONDITION

- When the OK idling cycle is completed 40 times in a row
- When "Clear Memory" is performed

7. MALFUNCTION INDICATOR LIGHT CLEAR CONDITION

- When the OK driving cycle is completed 3 times in a row
- When "Clear Memory" is performed

8. FAIL SAFE

Atmospheric pressure sensor process: Fix the atmospheric pressure to 101 kPa (760 mmHg, 29.8 inHg).

9. ECM OPERATION AT DTC SETTING

Memorize the freeze frame data. (For test mode \$02)

Diagnostic Trouble Code (DTC) Detecting Criteria

GENERAL DESCRIPTION

DS:DTC P2229 BAROMETRIC PRESSURE CIRCUIT HIGH

1. OUTLINE OF DIAGNOSIS

Detect the open/short circuit of the atmospheric pressure sensor.
Judge as NG if it is out of specification.

2. COMPONENT DESCRIPTION

The atmospheric pressure sensor is built into the ECM.

3. ENABLE CONDITION

Secondary Parameters	Enable Conditions
None	

4. GENERAL DRIVING CYCLE

Always perform the diagnosis continuously.

5. DIAGNOSTIC METHOD

Abnormality Judgment

Judge as NG when the continuous time of meeting the malfunction criteria below becomes 0.5 seconds or more.

Judgment Value

Malfunction Criteria	Threshold Value
Ignition switch	ON
Output voltage	≥ 4.936 V

Time Needed for Diagnosis: 0.5 seconds

Malfunction Indicator Light: Illuminates as soon as a malfunction occurs.

Normality Judgment

Judge as OK and clear the NG when the malfunction criteria below are met.

Judgment Value

Malfunction Criteria	Threshold Value
Ignition switch	ON
Output voltage	< 4.936 V

6. DTC CLEAR CONDITION

- When the OK idling cycle is completed 40 times in a row
- When "Clear Memory" is performed

7. MALFUNCTION INDICATOR LIGHT CLEAR CONDITION

- When the OK driving cycle is completed 3 times in a row
- When "Clear Memory" is performed

8. FAIL SAFE

Atmospheric pressure sensor process: Fix the atmospheric pressure to 101 kPa (760 mmHg, 29.8 inHg).

9. ECM OPERATION AT DTC SETTING

Memorize the freeze frame data. (For test mode \$02)

Diagnostic Trouble Code (DTC) Detecting Criteria

GENERAL DESCRIPTION
