

Engine Oil

LUBRICATION

3. Engine Oil

A: INSPECTION

- 1) Park the vehicle on a level surface.
- 2) Remove the oil level gauge and wipe away the oil.
- 3) Reinsert the level gauge all the way. Be sure that the level gauge is correctly inserted and properly orientated.
- 4) Remove it again and note the reading. If the engine oil level is below "L" line, add oil to bring the level up to "F" line.
- 5) After turning off the engine, wait a few minutes for the oil to return to the oil pan before checking the level.
- 6) Just after driving or while the engine is warm, engine oil level shows in the range between "F" line and cutout portion. This is caused by thermal expansion of engine oil.

NOTE:

To prevent overfilling of engine oil, do not add oil above "F" line when the engine is cold.

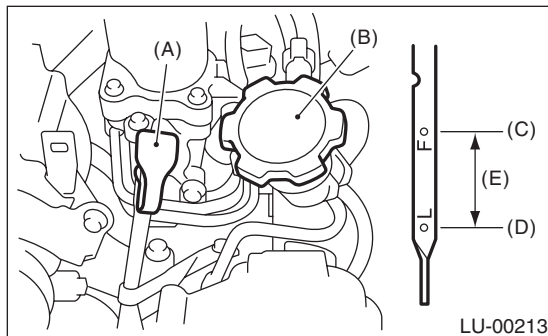

- (A) Oil level gauge
- (B) Engine oil filler cap
- (C) Upper level
- (D) Lower level
- (E) Approx. 1.0 ℓ (1.1 US qt, 0.9 Imp qt)

B: REPLACEMENT

- 1) Open the engine oil filler cap for quick draining of engine oil.
- 2) Lift-up the vehicle.
- 3) Remove the service hole clip located on the under cover.

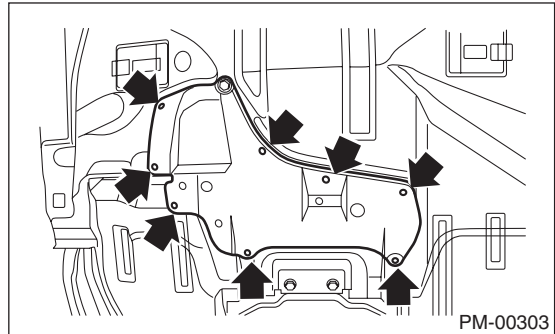

- 4) Rotate the service hole cover in the arrow direction.

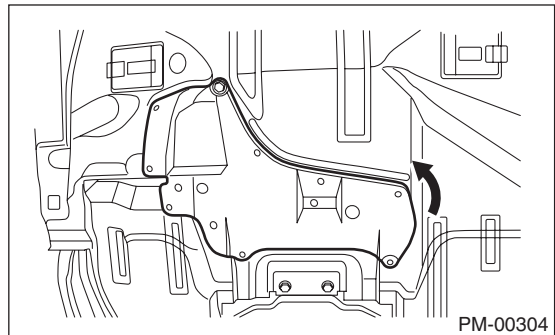

- 5) Drain engine oil by loosening the engine oil drain plug.

NOTE:

Prepare the container for draining of engine oil.

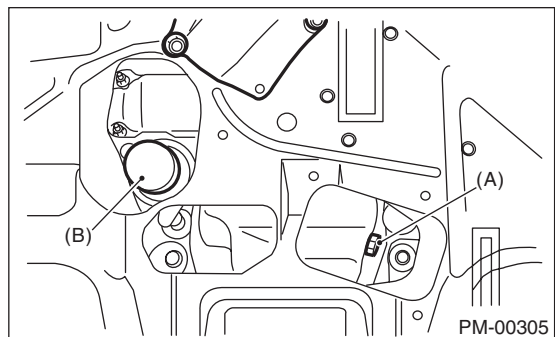

- (A) Drain plug
- (B) Oil filter

6) Tighten the engine oil drain plug after draining engine oil.

NOTE:

Use a new drain plug gasket.

Tightening torque:

44 N·m (4.5 kgf·m, 32.5 ft·lb)

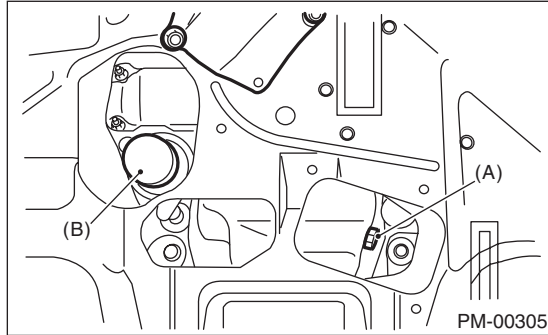

- (A) Drain plug
- (B) Oil filter

7) Install the service hole cover.

8) Using engine oil of proper quality and viscosity, fill engine oil through the oil filler duct to the upper level on level gauge. Make sure that the vehicle is parked on a level surface when checking oil level.

Recommended oil

<Ref. to LU (H4SO)-2, SPECIFICATION, General Description.>

Engine oil capacity:

<Ref. to LU (H4SO)-2, SPECIFICATION, General Description.>

9) Close the engine oil filler cap.

10) Start the engine and warm it up for a time.

11) After the engine stops, recheck the oil level. If necessary, add engine oil up to the upper level on level gauge.

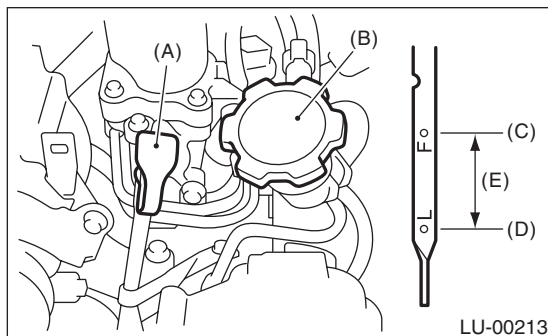

- (A) Oil level gauge
- (B) Engine oil filler cap
- (C) Upper level
- (D) Lower level
- (E) Approx. 1.0 ℓ (1.1 US qt, 0.9 Imp qt)