

5. Oil Pan and Strainer

A: REMOVAL

- 1) Set the vehicle on a lift.
- 2) Remove the front wheels.
- 3) Disconnect the ground cable from the battery.

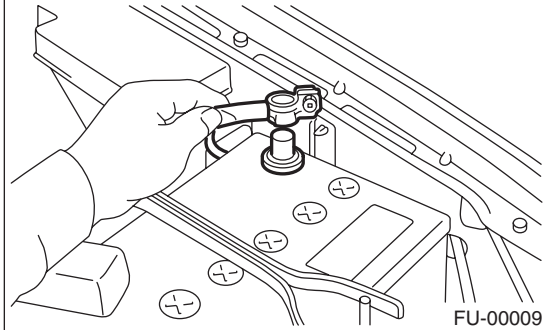

- 4) Remove the collector cover. (Turbo model)
- 5) Disconnect the connector from the mass air flow and intake air temperature sensor.

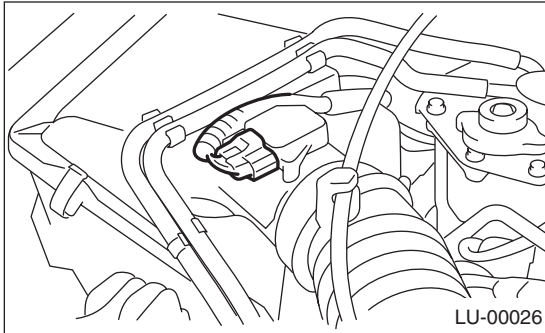

- 6) Remove the air intake duct and air cleaner case. (Non-turbo model) <Ref. to IN (H4SO)-7, REMOVAL, Air Intake Duct.> <Ref. to IN (H4SO)-5, REMOVAL, Air Cleaner Case.>
- 7) Remove the air intake boot and air cleaner upper cover. (Turbo model)

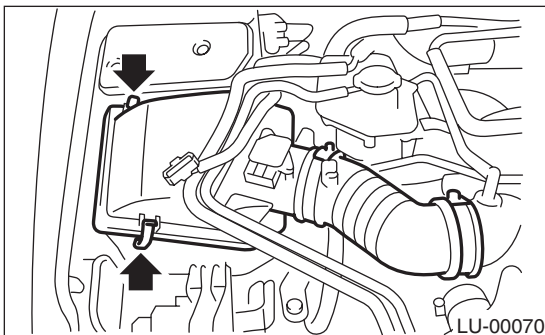

- 8) Remove the intercooler. (Turbo model) <Ref. to IN(H4DOTC)-11, REMOVAL, Intercooler.>

- 9) Remove the pitching stopper.

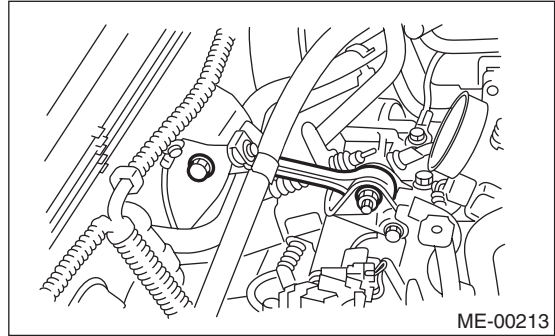

- 10) Remove the radiator upper brackets.

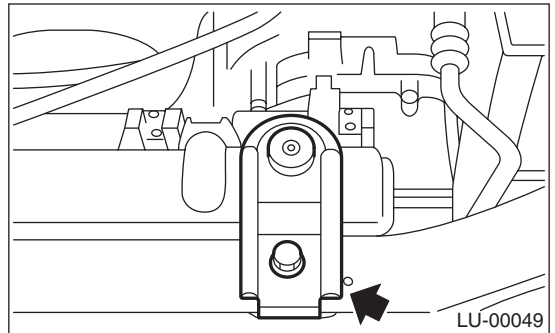

- 11) Support the engine with a lifting device and wire ropes.

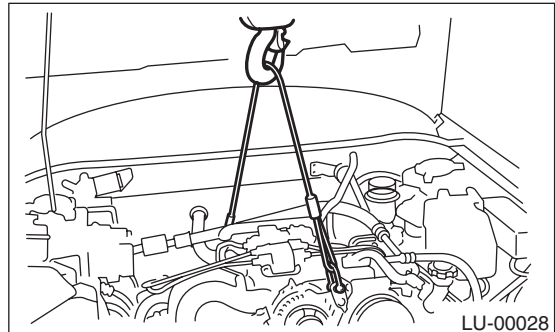

- 12) Lift-up the vehicle.

CAUTION:

When lifting up the vehicle, raise up wire ropes at the same time.

- 13) Remove the under cover.
- 14) Drain the engine oil. <Ref. to LU (H4SO)-10, REPLACEMENT, Engine Oil.>
- 15) Remove the front and center exhaust pipes. (Non-turbo model) <Ref. to EX (H4SO)-4, REMOVAL, Front Exhaust Pipe.>

Oil Pan and Strainer

LUBRICATION

16) Remove the nuts which install front cushion rubber onto front crossmember.

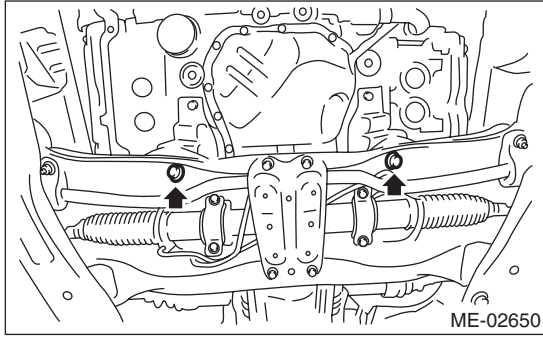

17) Remove the bolts which install oil pan on cylinder block with the engine raised up.

18) Insert the oil pan cutter blade into the gap between cylinder block and oil pan.

CAUTION:

Do not use a screwdriver or similar tool in place of oil pan cutter.

19) Remove the oil strainer.

20) Remove the baffle plate.

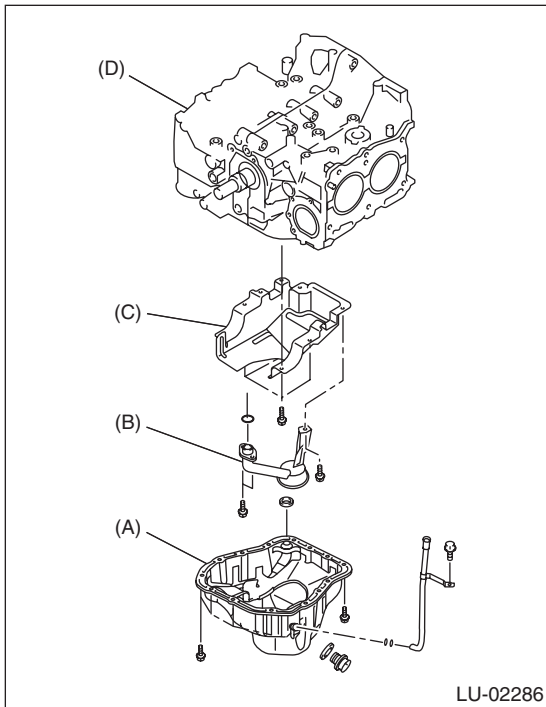

- (A) Oil pan
- (B) Oil strainer
- (C) Baffle plate
- (D) Cylinder block

B: INSTALLATION

CAUTION:

Before installing the oil pan, clean the mating surface of oil pan and engine block.

1) Make sure that the seals (A) are installed securely on the baffle plate in a direction as shown in the figure below.

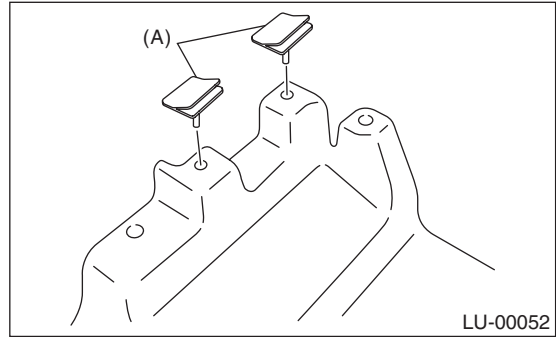

2) Install the baffle plate.

Tightening torque:

6.4 N·m (0.65 kgf-m, 4.7 ft-lb)

3) Install the oil strainer onto baffle plate.

NOTE:

Replace the O-ring with a new part.

Tightening torque:

10 N·m (1.0 kgf-m, 7.2 ft-lb)

4) Tighten the strainer stay together with the baffle plate.

Tightening torque:

6.4 N·m (0.65 kgf-m, 9.7 ft-lb)

5) Apply liquid gasket to the mating surfaces, and install the oil pan.

NOTE:

Install within 5 min. after applying liquid gasket.

Liquid gasket:

THREE BOND 1207C (Part No. 004403012) or equivalent

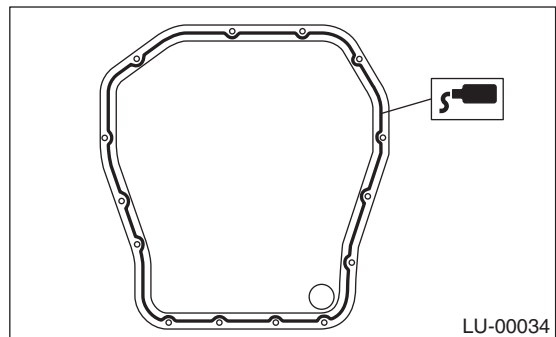

6) Tighten the bolt which installs oil pan to engine block.

Tightening torque:

5 N·m (0.5 kgf·m, 3.6 ft·lb)

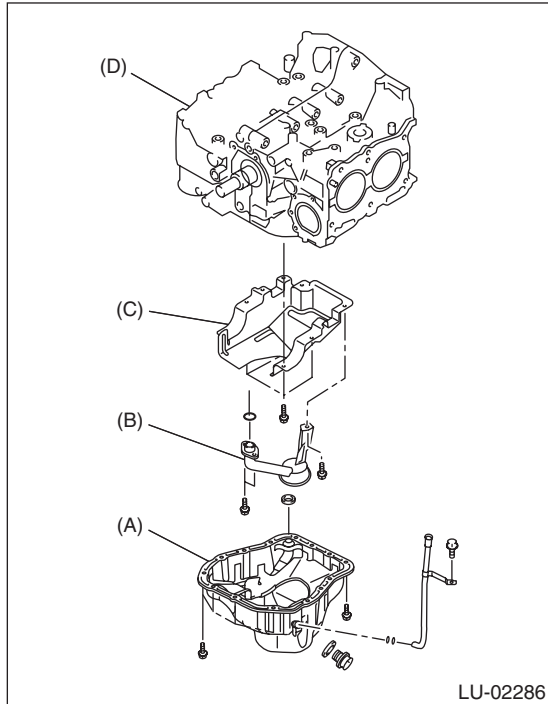

- (A) Oil pan
- (B) Oil strainer
- (C) Baffle plate
- (D) Cylinder block

7) Lower the engine onto front crossmember.
8) Install front cushion rubber onto front crossmember by tightening with nuts.

NOTE:

Make sure the front cushion rubber mounting bolts (A) and locator (B) are securely installed.

Tightening torque:

85 N·m (8.7 kgf·m, 63 ft·lb)

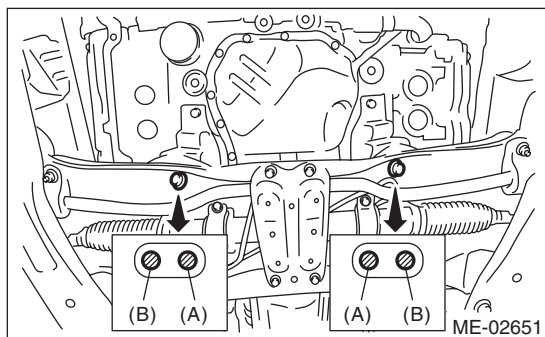

9) Install the front and center exhaust pipe. (Non-turbo model) <Ref. to EX (H4SO)-5, INSTALLATION, Front Exhaust Pipe.>

NOTE:

Use a new gasket.

- 10) Install the under cover.
- 11) Lower the vehicle.

CAUTION:

When lowering the vehicle, lower the lift-up device and wire ropes at the same time.

- 12) Remove the lifting device and wire ropes.

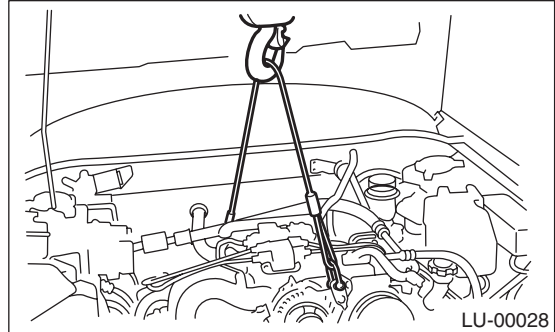

- 13) Install the pitching stopper.

Tightening torque:

T1: 50 N·m (5.1 kgf·m, 36.9 ft·lb)

T2: 58 N·m (5.9 kgf·m, 42.8 ft·lb)

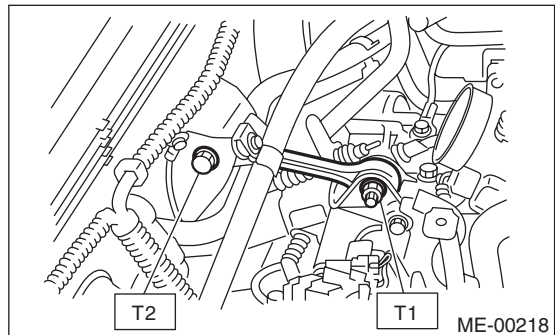

- 14) Install the radiator upper brackets.

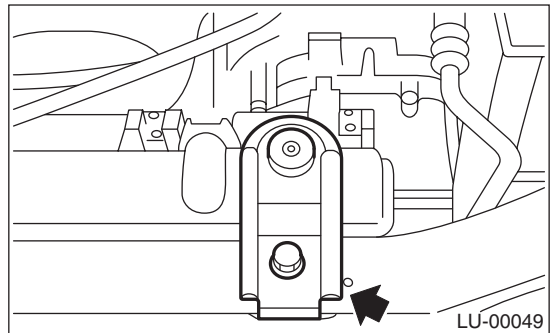

15) Install the air intake duct and air cleaner case. (Non-turbo model) <Ref. to IN (H4SO)-7, INSTALLATION, Air Intake Duct.> <Ref. to IN (H4SO)-5, INSTALLATION, Air Cleaner Case.>

16) Install the intercooler. (Turbo model) <Ref. to IN(H4DOTC)-11, INSTALLATION, Intercooler.>

Oil Pan and Strainer

LUBRICATION

17) Install the air intake boot and air cleaner upper cover. (Turbo model)

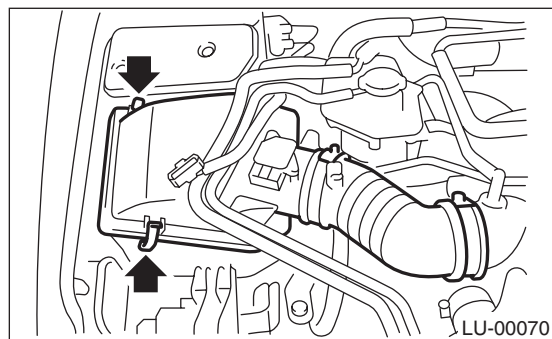

18) Connect the connector to the mass air flow and intake air temperature sensor.

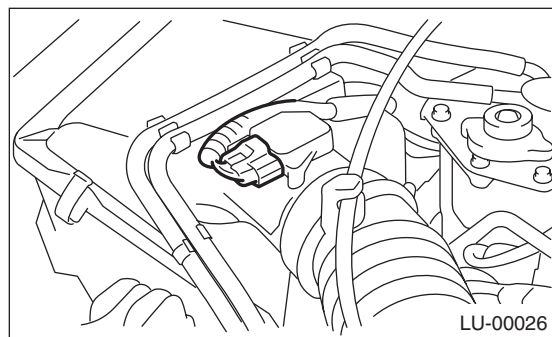

19) Install the front wheels.

20) Connect the ground cable to the battery.

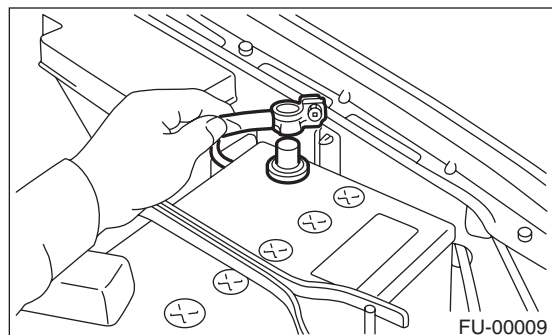

21) Refill the engine oil. <Ref. to LU (H4SO)-10, INSPECTION, Engine Oil.>

22) Install the collector cover. (Turbo model)

C: INSPECTION

Visually check that the oil pan, oil strainer, oil strainer stay and baffle plate are not damaged.