

6. Oil Pressure Switch

A: REMOVAL

- 1) Remove the collector cover. (Turbo model)
- 2) Remove the generator from bracket. <Ref. to SC (H4SO)-14, REMOVAL, Generator.>
- 3) Disconnect the terminal from oil pressure switch.

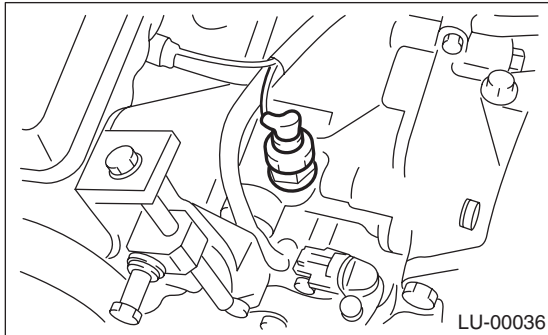

- 4) Remove the oil pressure switch.

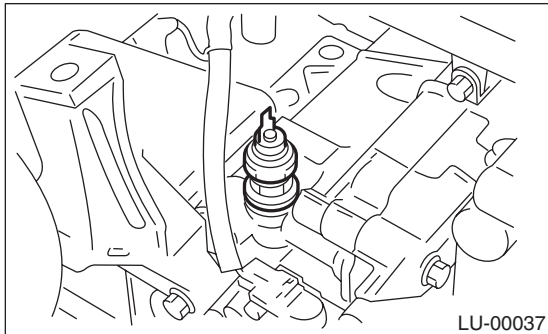

B: INSTALLATION

- 1) Apply liquid gasket to the oil pressure switch threads.

Liquid gasket:

THREE BOND 1324 (Part No. 004403042) or equivalent

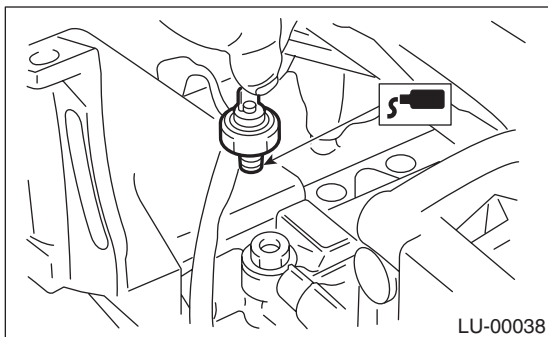

- 2) Install the oil pressure switch onto engine block.

Tightening torque:

25 N·m (2.5 kgf-m, 18.1 ft-lb)

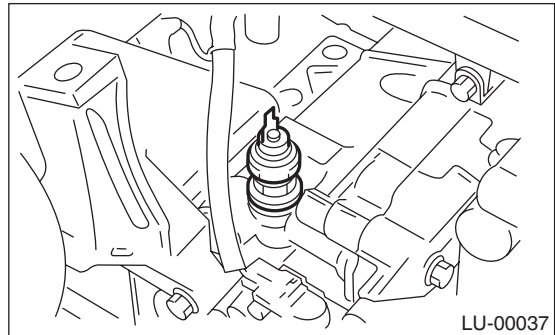

- 3) Connect the terminal to the oil pressure switch.

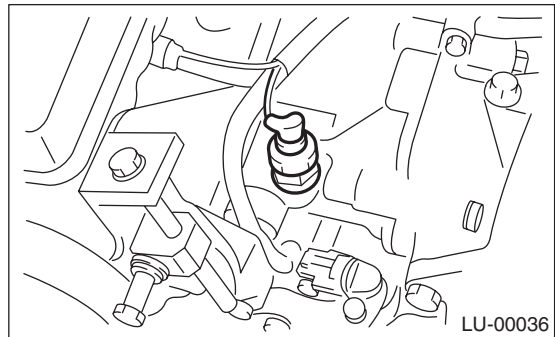

- 4) Install the generator to bracket. <Ref. to SC (H4SO)-14, INSTALLATION, Generator.>
- 5) Install the collector cover. (Turbo model)

C: INSPECTION

Check the oil pressure switch installation portion for oil leakage and oil seepage.