

6. Engine Oil Pressure

A: INSPECTION

- 1) Remove the oil pressure switch. <Ref. to LU (H4SO)-21, REMOVAL, Oil Pressure Switch.>
- 2) Connect the oil pressure gauge to cylinder block.
- 3) Connect the ground cable to the battery.

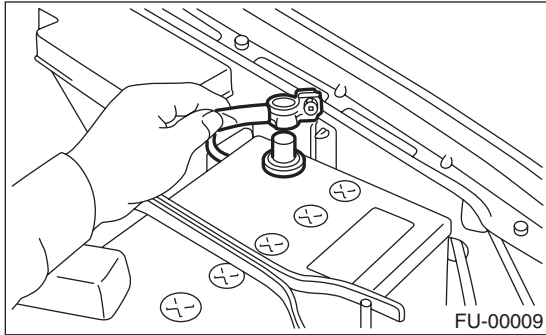

- 4) Start the engine, and measure the oil pressure.

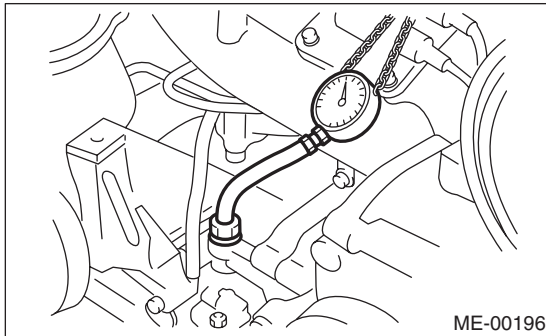

Oil pressure:

Standard:

98 kPa (1.0 kg/cm², 14 psi) or more at 600 rpm
294 kPa (3.0 kg/cm², 43 psi) or more at 5,000 rpm

CAUTION:

- If the oil pressure is out of standard values, check the oil pump, oil filter and lubrication line. <Ref. to LU (H4SO)-25, INSPECTION, Engine Lubrication System Trouble in General.>
- If the oil pressure warning light is turned on and oil pressure is in the specified range, check the oil pressure switch. <Ref. to LU (H4SO)-25, INSPECTION, Engine Lubrication System Trouble in General.>

NOTE:

Standard value is based on an engine oil temperature of 80°C (176°F).

- 5) After measuring the oil pressure, install the oil pressure switch. <Ref. to LU (H4SO)-21, INSTALLATION, Oil Pressure Switch.>

Tightening torque:

25 N·m (2.5 kgf·m, 18.1 ft·lb)