

12.V-belt

A: REMOVAL

NOTE:

Perform the work with the engine installed to body when replacing a single part.

1. FRONT SIDE BELT

- 1) Remove the V-belt covers.

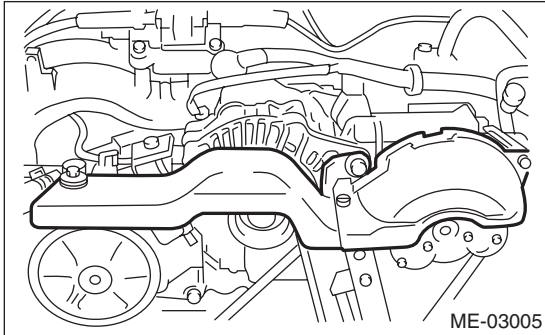

- 2) Loosen the lock bolt (A).
- 3) Loosen the slider bolt (B).
- 4) Remove the front side belt (C).

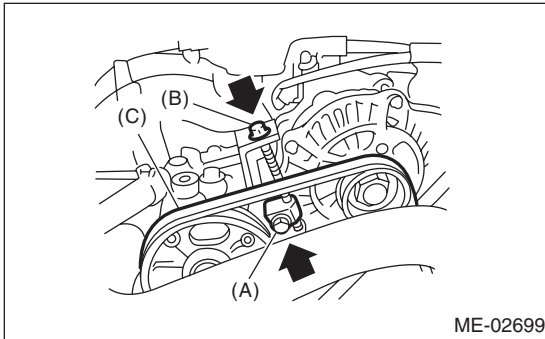

2. REAR SIDE BELT

- 1) Loosen the lock nut (A).
- 2) Loosen the slider bolt (B).

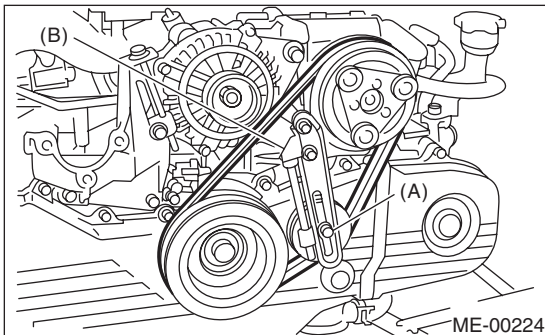

- 3) Remove the rear side belt.

- 4) Remove the belt tensioner.

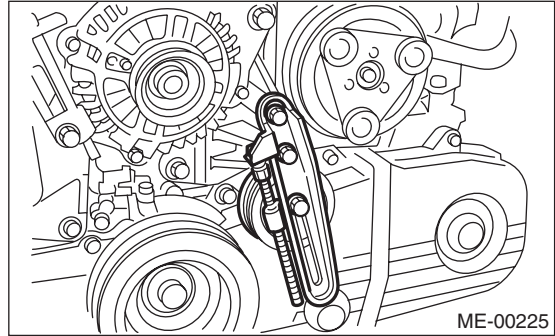

B: INSTALLATION

CAUTION:

Wipe off any oil and water on the belt and pulley.

1. FRONT SIDE BELT

- 1) Install the front side belt (C), and tighten the slider bolt so as to obtain the specified belt tension. <Ref. to ME(H4SO)-41, INSPECTION, V-belt.>
- 2) Tighten the lock bolt (A).
- 3) Tighten the slider bolt (B).

Tightening torque:

Lock bolt (A)

25 N·m (2.5 kgf-m, 18.1 ft-lb)

Slider bolt (B)

8 N·m (0.8 kgf-m, 5.8 ft-lb)

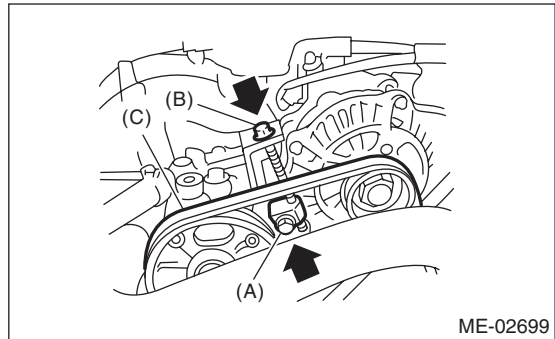

2. REAR SIDE BELT

- 1) Install the belt tensioner.
- 2) Install a rear side belt, and tighten the slider bolt (B) so as to obtain the specified belt tension.
<Ref. to ME(H4SO)-41, INSPECTION, V-belt.>
- 3) Tighten the lock nut (A).

Tightening torque:

Lock nut (A)

23 N·m (2.3 kgf-m, 17.0 ft-lb)

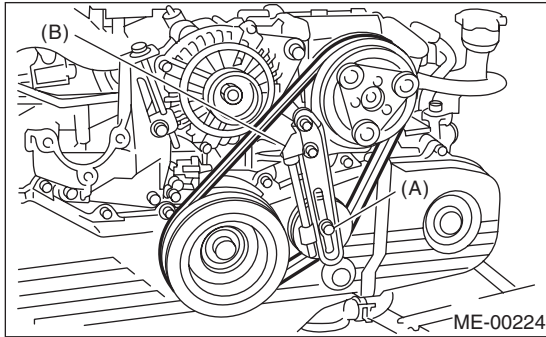

C: INSPECTION

- 1) Replace the belts, if crack, fraying or wear is found.
- 2) Remove the V-belt cover and reservoir tank. (with belt tension gauge)
- 3) Check the V-belt tension and adjust it if necessary by changing the generator installing position or idler pulley installing position.

Belt tension (with belt tension gauge):

(A)

When installing new parts

640 — 780 N (65 — 80 kgf, 144 — 175 lb)

At inspection

490 — 640 N (50 — 65 kgf, 110 — 144 lb)

(B)

When installing new parts

650 — 750 N (66 — 76 kgf, 146 — 169 lb)

At inspection

350 — 450 N (36 — 46 kgf, 78 — 101 lb)

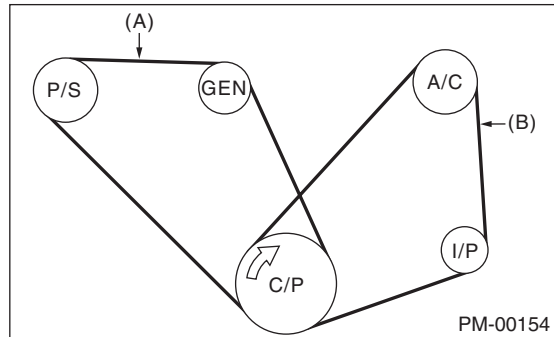

- (A) Front side belt
- (B) Rear side belt
- C/P Crank pulley
- GEN Generator
- P/S Power steering oil pump pulley
- A/C Air conditioning compressor pulley
- I/P Idler pulley

Belt tension (without belt tension gauge):

(A)

When installing new parts

7 — 9 mm (0.276 — 0.354 in)

At inspection

9 — 11 mm (0.354 — 0.433 in)

(B)

When installing new parts

7.5 — 8.5 mm (0.295 — 0.335 in)

At inspection

9.0 — 10.0 mm (0.354 — 0.394 in)

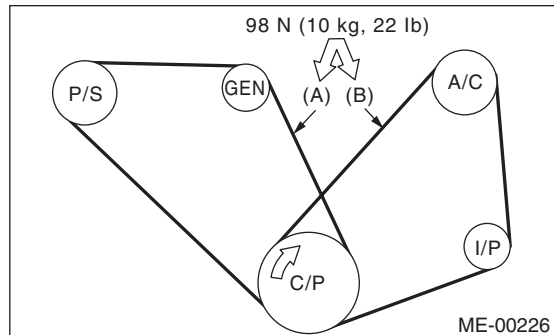

- (A) Front side belt
- (B) Rear side belt
- C/P Crank pulley
- GEN Generator
- P/S Power steering oil pump pulley
- A/C Air conditioning compressor pulley
- I/P Idler pulley