

13.Crank Pulley

A: REMOVAL

NOTE:

Perform the work with the engine installed to body when replacing a single part.

1) Remove the V-belts. <Ref. to ME(H4SO)-40, REMOVAL, V-belt.>

2) Remove the crank pulley bolt. To lock the crankshaft, use ST.

ST 499977100 CRANK PULLEY WRENCH

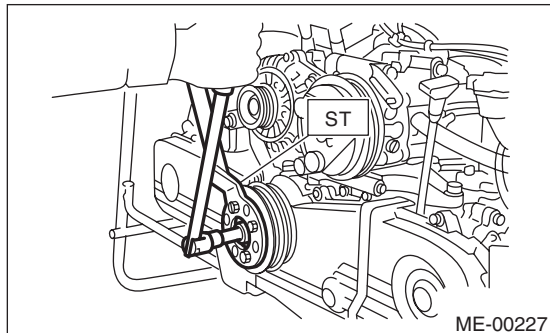

3) Remove the crank pulley.

B: INSTALLATION

1) Install the crank pulley.

2) Install the pulley bolt.

To lock the crankshaft, use ST.

ST 499977100 CRANK PULLEY WRENCH

(1) Clean the crankshaft thread using compressed air.

(2) Apply engine oil to the crank pulley bolt seat and thread.

(3) Tighten the bolts temporarily with tightening torque of 44 N·m (4.5 kgf·m, 33 ft·lb).

(4) Tighten the crank pulley bolts.

Tightening torque:

180 N·m (18.4 kgf·m, 132.8 ft·lb)

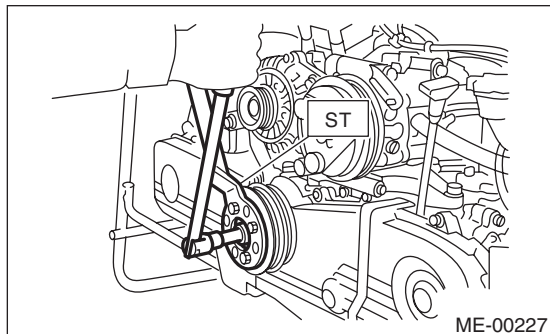

3) Check that the tightening angle of the clamp pulley bolt is a minimum of 65°. Perform the following procedure when less than 65°.

CAUTION:

If the tightening angle of crank pulley bolt is less than 65°, the bolt is damaged. In this case, the bolt must be replaced.

(1) Replace the crank pulley bolts and clean them.

Crank pulley bolt:

12369AA011

(2) Clean the crankshaft thread using compressed air.

(3) Apply engine oil to the crank pulley bolt seat and thread.

(4) Tighten the bolts temporarily with tightening torque of 44 N·m (4.5 kgf·m, 33 ft·lb).

(5) Tighten the crank pulley bolt keeping them in an angle between 65° and 75°.

NOTE:

Conduct the tightening procedures by confirming the turning angle of crank pulley bolt referring to the gauge indicated on timing belt cover.

4) Install the belt tensioner.

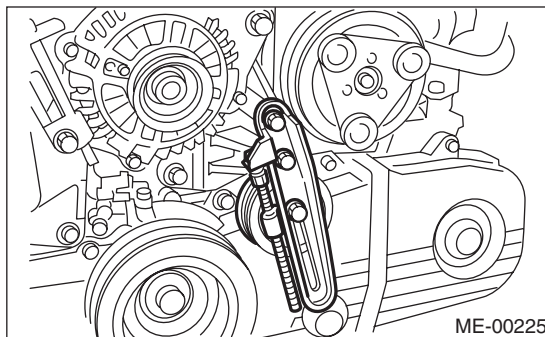

5) Install the V-belts. <Ref. to ME(H4SO)-40, INSTALLATION, V-belt.>

C: INSPECTION

1) Make sure the V-belt is not worn or otherwise damaged.

2) Check the tension of the belt. <Ref. to ME(H4SO)-41, INSPECTION, V-belt.>