

11. Cooling System

A: INSPECTION

1) To check the radiator for leakage, fill it with engine coolant, and attach the radiator cap tester (A) to the filler neck, and apply pressure.

Pressure:

Non-turbo model

157 kPa (1.6 kg/cm², 23 psi)

Turbo model

122 kPa (1.2 kg/cm², 18 psi)

Check the following points:

- Leak from radiator
- Hose joints and other connections for leakage

CAUTION:

- For Turbo model, inspection must be carried out at the side of coolant filler tank, not at the side of radiator.
- Be particularly careful not to deform the filler neck of radiator when installing and removing the tester and after testing.
- When performing this check, be sure to keep the engine stationary and fill radiator with coolant.
- Wipe off check points before applying pressure.
- Use care not to spill coolant when detaching tester from radiator.
- Non-turbo model

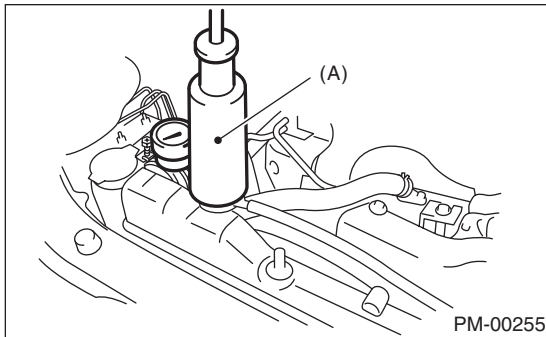

- Turbo model

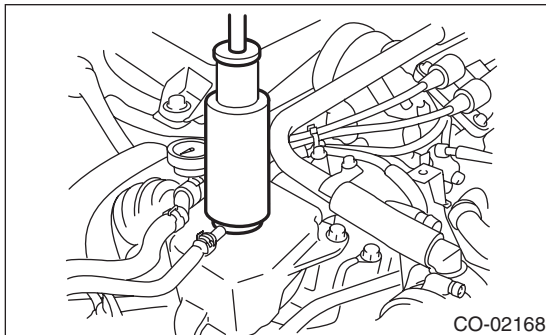

2) Check the radiator cap valve open pressure using radiator cap tester.

Raise the pressure until the needle of gauge stops and see if the pressure can be retained for five to six seconds. The radiator cap is normal if a pressure above the service limit value has been maintained for this period.

CAUTION:

Rust or dirt on the cap may prevent valve from functioning normally: be sure to clean the cap before testing.

Non-turbo model radiator side and turbo model coolant filler tank side

Specification:

93 — 123 kPa (0.95 — 1.25 kg/cm², 14 — 18 psi)

Service limit pressure:

83 kPa (0.85 kg/cm², 12 psi)

Radiator side on turbo models

Specification:

122 — 152 kPa (1.24 — 1.55 kg/cm², 18 — 22 psi)

Service limit pressure:

112 kPa (1.14 kg/cm², 16 psi)

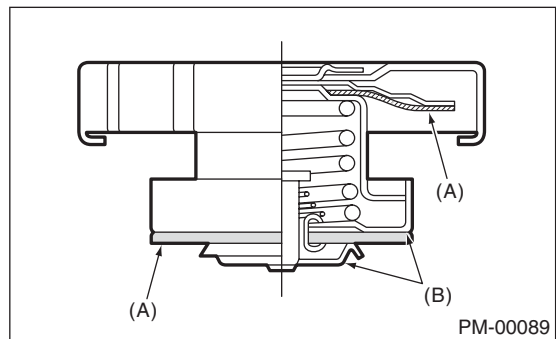
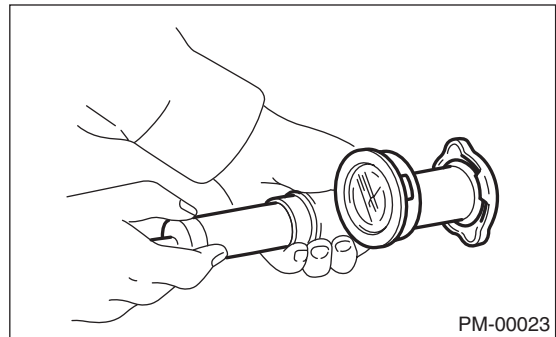

- (A) Check points for deformation
- (B) Check points for deformation, damage, rust

Cooling System

PERIODIC MAINTENANCE SERVICES

3) Start the engine, and then inspect that it does not overheat or it is cooled excessively. If it overheats or it is cooled excessively, check the cooling system. <Ref. to CO(H4SO)-24, INSPECTION, Water Pump.> <Ref. to CO(H4SO)-26, INSPECTION, Thermostat.> <Ref. to CO(H4SO)-27, Radiator.> <Ref. to CO(H4SO)-33, Radiator Cap.>

4) Check the radiator fan operates using Subaru Select Monitor, when the coolant temperature exceeds 95°C (203°F). If it does not operate, check the radiator fan system. <Ref. to CO(H4SO)-12, Radiator Fan System.>