

ATTENTION:

GENERAL MANAGER PARTS MANAGER
 CLAIMS PERSONNEL SERVICE MANAGER

IMPORTANT - All Service Personnel Should Read and Initial



SERVICE BULLETIN

APPLICABILITY: 2002 Impreza and Legacy
SUBJECT: Service Manual Corrections

NUMBER: 18-71-03
DATE: 02/21/03

INTRODUCTION

Place a REVISED label on the appropriate page of the noted effected Service Manual and update the Service Manual Correction Binder with the following pages:

Model	Year	Book/Vol#	MSA#	Section	Page	Reference
Legacy	2002	3	MSA5T0203A	LU(H6)	2	N/A
Impreza	2002	3	MSA5T0212A	ME(DOHC TURBO)	8	N/A
				ME(DOHC TURBO)	9	N/A
				ME(DOHC TURBO)	60	N/A
				ME(DOHC TURBO)	62	N/A



CAUTION: VEHICLE SERVICING PERFORMED BY UNTRAINED PERSONS COULD RESULT IN SERIOUS INJURY TO THOSE PERSONS OR TO OTHERS.

Subaru Service Bulletins are intended for use by professional technicians ONLY. They are written to inform those technicians of conditions that may occur in some vehicles, or to provide information that could assist in the proper servicing of the vehicle. Properly trained technicians have the equipment, tools, safety instructions, and know-how to do the job correctly and safely. If a condition is described, DO NOT assume that this Service Bulletin applies to your vehicle, or that your vehicle will have that condition.



GENERAL DESCRIPTION

Lubrication

1. General Description S148001

A: SPECIFICATIONS S148001E49

Lubrication method		Forced lubrication	
Oil pump	Pump type	Trochoid type	
	Number of teeth	Inner rotor	9
		Outer rotor	10
	Outer rotor diameter × thickness		78 × 11 mm (3.07 × 0.43 in)
	Tip clearance between inner and outer rotors	STANDARD	0.04 — 0.14 mm (0.0016 — 0.0055 in)
		LIMIT	0.20 mm (0.0079 in)
	Side clearance between inner rotor and pump case	STANDARD	0.02 — 0.08 mm (0.0008 — 0.0031 in)
		LIMIT	0.15 mm (0.0059 in)
Case clearance between outer rotor and pump case	STANDARD	0.11 — 0.18 mm (0.0043 — 0.0071 in)	
	LIMIT	0.25 mm (0.0098 in)	
Oil filter	Type	Full-flow filter type	
	Filtration area	1,300 cm ² (201.5 sq in)	
	By-pass valve opening pressure	160 kPa (1.63 kg/cm ² , 23 psi)	
	Outer diameter × width	80 × 75 mm (3.15 × 2.95 in)	
	Oil filter to engine thread size	M 20 × 1.5	
Relief valve operation pressure		588 kPa (6 kg/cm ² , 85 psi)	
Oil pressure switch	Type	Immersed contact point type	
	Working voltage — wattage	12 V — 3.4 W or less	
	Warning light activation pressure	15 kPa (0.153 kg/cm ² , 2.2 psi)	
	Proof pressure	More than 980 kPa (9.993 kg/cm ² , 142 psi)	
Oil capacity	Total capacity	6.8 ℓ (7.2 US qt, 6.0 Imp qt)	
	Engine oil amount for refill	5.8 ℓ (6.1 US qt, 5.1 Imp qt)	

LU(H6)-2

GENERAL DESCRIPTION

MECHANICAL

2. CYLINDER HEAD AND CAMSHAFT

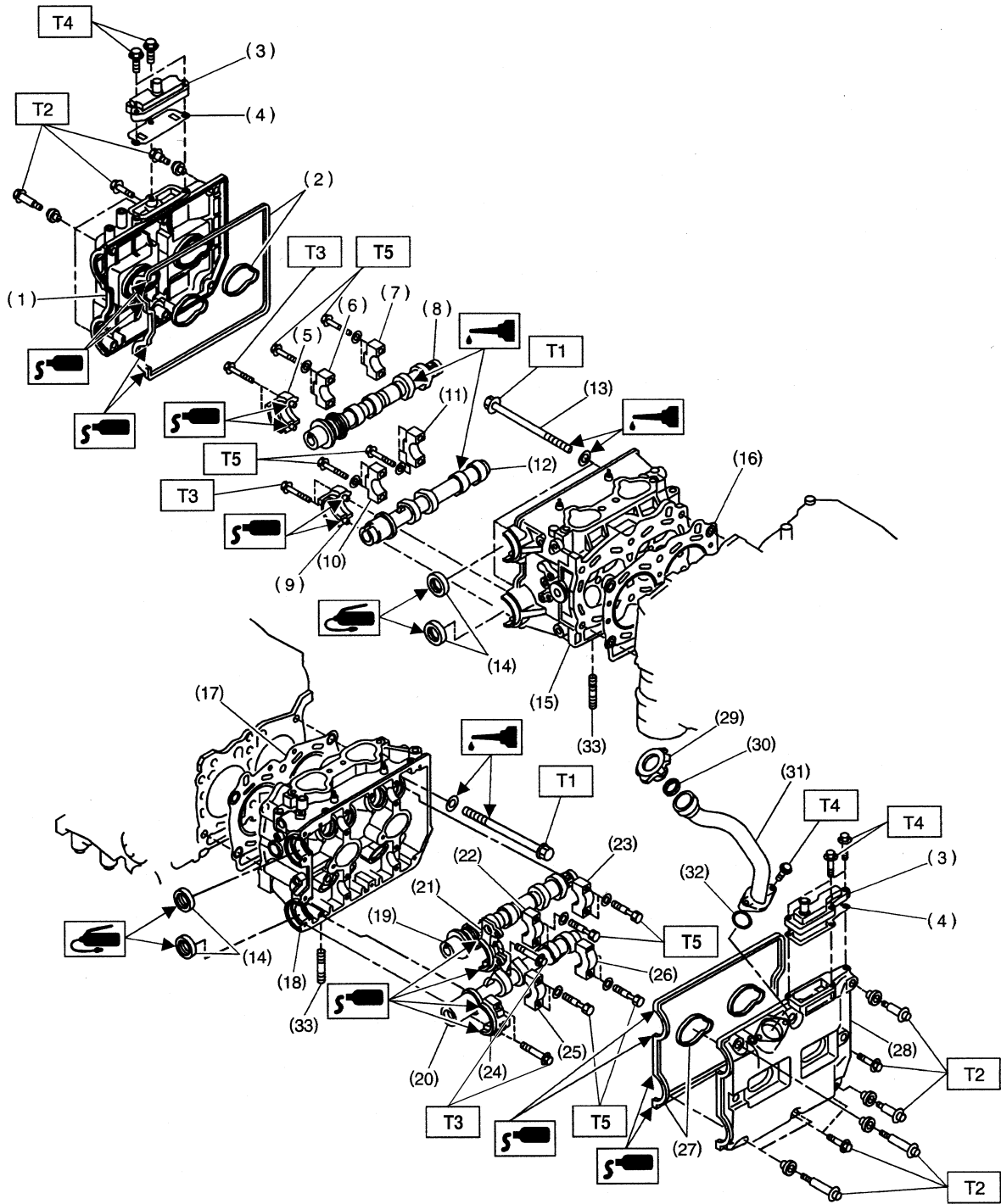

S2M1188A

ME(DOHC TURBO)-8

GENERAL DESCRIPTION

MECHANICAL

-
- | | | |
|---------------------------------------|---------------------------------------|----------------------|
| (1) Rocker cover (RH) | (15) Cylinder head (RH) | (29) Oil filler cap |
| (2) Rocker cover gasket (RH) | (16) Cylinder head gasket (RH) | (30) Gasket |
| (3) Oil separator cover | (17) Cylinder head gasket (LH) | (31) Oil filler duct |
| (4) Gasket | (18) Cylinder head (LH) | (32) O-ring |
| (5) Intake camshaft cap (Front RH) | (19) Intake camshaft (LH) | (33) Stud bolt |
| (6) Intake camshaft cap (Center RH) | (20) Exhaust camshaft (LH) | |
| (7) Intake camshaft cap (Rear RH) | (21) Intake camshaft cap (Front LH) | |
| (8) Intake camshaft (RH) | (22) Intake camshaft cap (Center LH) | |
| (9) Exhaust camshaft cap (Front RH) | (23) Intake camshaft cap (Rear LH) | |
| (10) Exhaust camshaft cap (Center RH) | (24) Exhaust camshaft (Front LH) | |
| (11) Exhaust camshaft cap (Rear RH) | (25) Exhaust camshaft cap (Center LH) | |
| (12) Exhaust camshaft (RH) | (26) Exhaust camshaft cap (Rear LH) | |
| (13) Cylinder head bolt | (27) Rocker cover gasket (LH) | |
| (14) Oil seal | (28) Rocker cover (LH) | |

Tightening torque: N·m (kgf-m, ft-lb)

T1: <Ref. to ME(DOHC TURBO)-64, INSTALLATION, Cylinder Head Assembly.>

T2: 5 (0.5, 3.6)

T3: 10 (1.0, 7.3)

T4: 6.4 (0.65, 4.7)

T5: 20 (2.0, 14.7)

ME(DOHC TURBO)-9

CAMSHAFT

MECHANICAL

B: INSTALLATION

1) Camshaft installation:

Apply engine oil to the cylinder head at camshaft bearing location before installing the camshaft. Install the camshaft so that each valves is close to or in contact with "base circle" of cam lobe.

CAUTION:

- When the camshafts are positioned as shown in the figure, camshafts need to be rotated at a minimum to align with the timing belt during installation.
 - Right-hand camshaft need not be rotated when set at the position shown in the figure.
- Left-hand intake camshaft: Rotate 80° clockwise.
Left-hand exhaust camshaft: Rotate 45° counterclockwise.

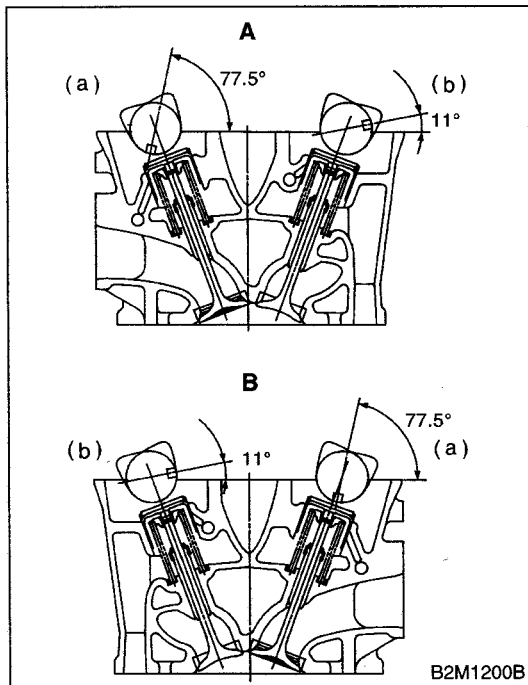

- A Left side cylinder head
B Right side cylinder head
(a) Intake camshaft
(b) Exhaust camshaft

2) Camshaft cap installation:

- (1) Apply fluid packing sparingly to the cap mating surface.

CAUTION:

Do not apply fluid packing excessively. Failure to do so may cause excess packing to come out and flow toward oil seal, resulting in oil leaks.

Fluid packing:

THREE BOND 1215 or equivalent

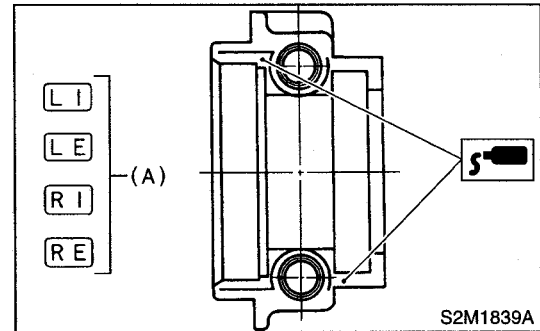

- (2) Apply engine oil to cap bearing surface and install the cap on camshaft as shown by identification mark (A).

- (3) Gradually tighten the cap in at least two stages in alphabetical sequence shown in the figure, and then tighten to specified torque.

Tightening torque:

T1: 10 N·m (1.0 kgf·m, 7.3 ft·lb)

T2: 20 N·m (2.0 kgf·m, 14.7 ft·lb)

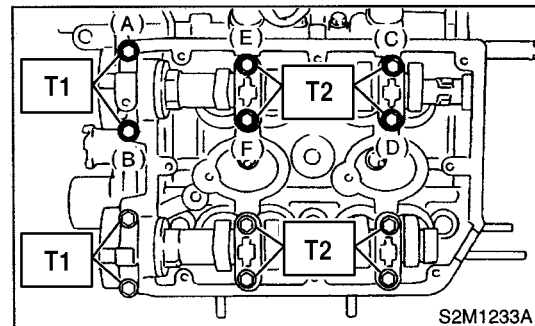

- (4) Similarly, tighten the cap on exhaust side. After tightening the cap, ensure the camshaft rotates only slightly while holding it at "base" circle.

Tightening torque:

T1: 10 N·m (1.0 kgf·m, 7.3 ft·lb)

T2: 20 N·m (2.0 kgf·m, 14.7 ft·lb)

ME(DOHC TURBO)-60

CAMSHAFT

MECHANICAL

- 14) Install the crankshaft pulley. <Ref. to ME(DOHC TURBO)-46, INSTALLATION, Crankshaft Pulley.>
 15) Install the V-belt. <Ref. to ME(DOHC TURBO)-44, INSTALLATION, V-belt.>

C: INSPECTION

- 1) Measure the bend, and repair or replace if necessary.

Limit:

0.020 mm (0.0008 in)

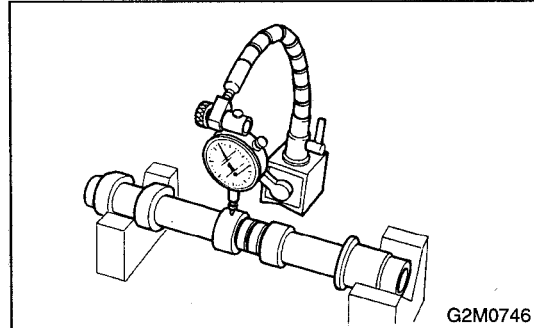

- 2) Check the journal for damage and wear. Replace if faulty.
 3) Measure the outside diameter of camshaft journal. If the journal diameter is not as specified, check the oil clearance.

	Camshaft journal	
	Front	Center, rear
Standard	37.946 — 37.9635 mm (1.4939 — 1.4946 in)	29.946 — 29.963 mm (1.1790 — 1.1796 in)

- 4) Measurement of the camshaft journal oil clearance:

- (1) Clean the bearing caps and camshaft journals.
- (2) Place the camshafts on the cylinder head. (Without installing the valve rocker.)
- (3) Place a plastigauge across each of the camshaft journals.
- (4) Gradually tighten the cap in at least two stages in alphabetical sequence shown in the figure, and then tighten to specified torque.

Tightening torque:

T1: 10 N·m (1.0 kgf·m, 7.3 ft·lb)

T2: 20 N·m (2.0 kgf·m, 14.7 ft·lb)

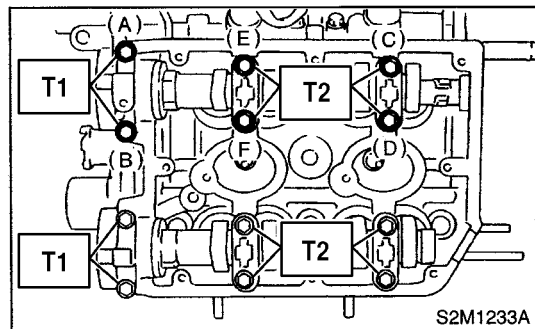

CAUTION:
 Do not turn the camshaft.

ME(DOHC TURBO)-62