

Flywheel

CLUTCH SYSTEM

3. Flywheel

A: REMOVAL

1) Remove the transmission assembly. <Ref. to 5MT-26, REMOVAL, Manual Transmission Assembly.>

2) Remove the clutch cover and clutch disc. <Ref. to CL-12, REMOVAL, Clutch Disc and Cover.>

3) Using the ST, remove the flywheel.

ST 498497100 CRANKSHAFT STOPPER

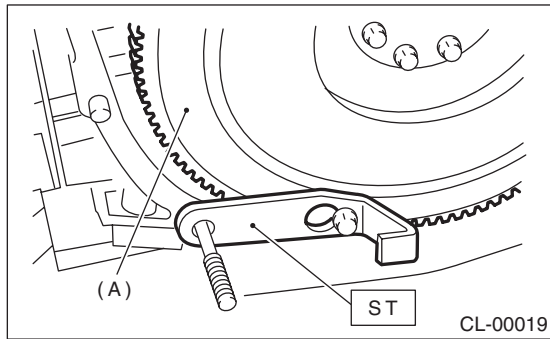

(A) Flywheel

B: INSTALLATION

1) Install the flywheel and ST.

ST 498497100 CRANKSHAFT STOPPER

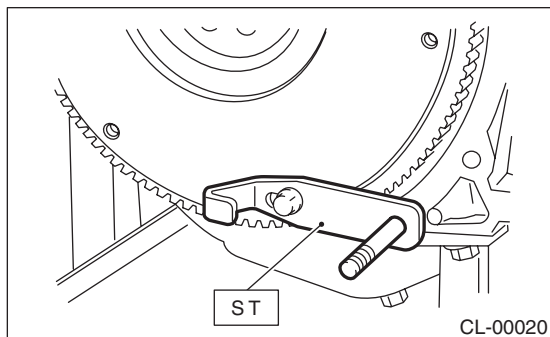

2) Tighten the flywheel attaching bolts to the specified torque.

NOTE:

Tighten the flywheel attachment bolts gradually. Each bolt should be tightened to the specified torque in crisscross order.

Tightening torque:

72 N·m (7.3 kgf-m, 52.8 ft-lb)

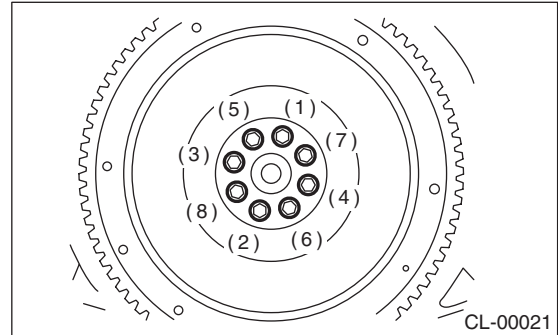

3) Install the clutch disc and cover. <Ref. to CL-12, INSTALLATION, Clutch Disc and Cover.>

4) Install the transmission assembly. <Ref. to 5MT-28, INSTALLATION, Manual Transmission Assembly.>

C: INSPECTION

CAUTION:

Since this bearing is grease-sealed and is a non-lubrication type, do not wash with gasoline or any solvents.

1) Damage of facing and ring gear

If there is a problem, replace the flywheel.

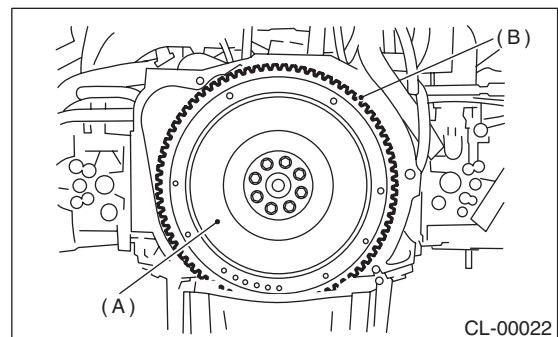

(A) Flywheel

(B) Ring gear

2) Smoothness of rotation

Rotate the ball bearing while applying pressure in thrust direction.

3) If noise or excessive play is noted, replace the flywheel.