

4. Release Bearing and Lever

A: REMOVAL

- 1) Remove the transmission assembly from vehicle body.
<Ref. to 5MT-26, REMOVAL, Manual Transmission Assembly.>
- 2) Remove the two clips from the release lever and remove the release bearing. (Non-turbo model)
- 3) Remove the release bearing from release lever. (Turbo model)

CAUTION:

Be careful not to deform the clips.

- 4) Remove the release lever dust cover.

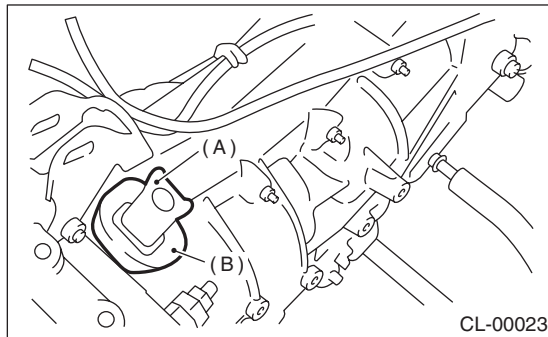

(A) Release lever
(B) Release lever dust cover

- 5) Remove the lever spring from release lever pivot with a screwdriver, by accessing it through the clutch housing release lever hole. Then remove the release lever.

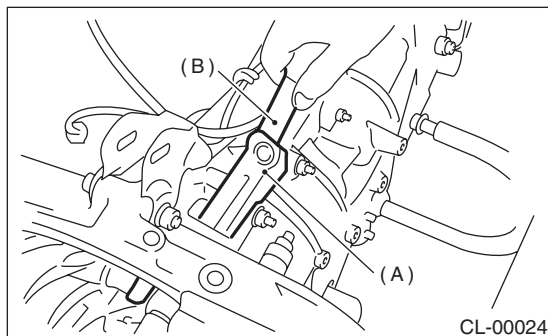

(A) Release lever
(B) Screwdriver

B: INSTALLATION

- 1) Lubricate the following points with the specified grease prior to assembly.
 - Contact surface of release lever and pivot
 - Contact surface of release lever and bearing
 - Transmission main shaft spline (Use grease containing molybdenum disulphide.)
 - Contact surface of release lever and operating cylinder
- 2) While pushing the release lever against the pivot and twisting left and right, fit the spring onto the stepped portion of pivot. Apply grease (KOPR-KOTE: Part No. 003603001) to the contact point of the release lever and the operating cylinder.
- 3) Confirm that the lever spring is securely fitted by observing it through the main case hole.

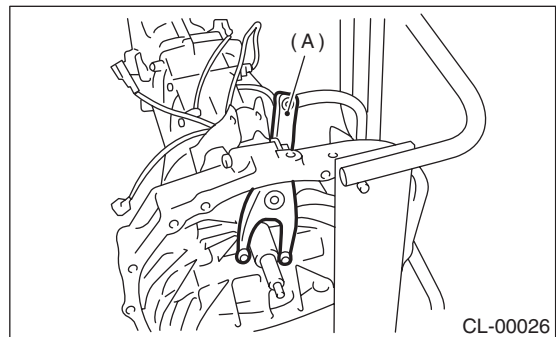

(A) Release lever

- 4) Install the release bearing and fasten it with two clips. (Non-turbo model)
- 5) Install the release bearing. (Turbo model)
- 6) Install the release lever dust cover.

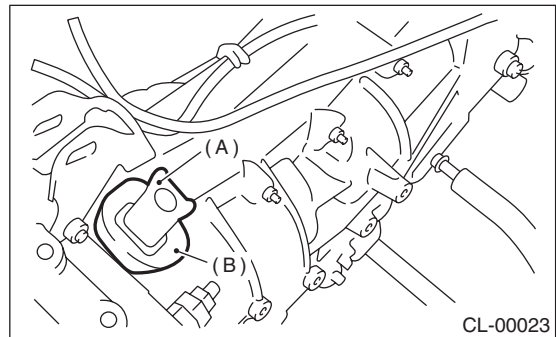

(A) Release lever
(B) Release lever dust cover

- 7) Check the bearing for smooth movement by operating the release lever.
- 8) Install the transmission assembly.
<Ref. to 5MT-28, INSTALLATION, Manual Transmission Assembly.>

Release Bearing and Lever

CLUTCH SYSTEM

C: INSPECTION

1. RELEASE BEARING

CAUTION:

Since this bearing is grease-sealed and is a non-lubrication type, do not wash with gasoline or any other solvent when servicing the clutch.

1) Check the bearing for smooth movement by applying force to the bearing in radial direction.

Radial direction stroke:

1.6 mm (0.063 in)

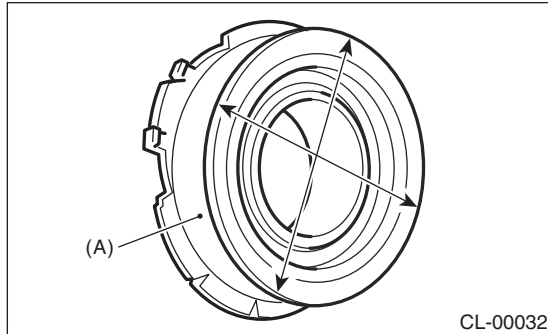

(A) Bearing case

2) While applying force to the bearing in the direction of rotation, check the bearing for smooth rotation.

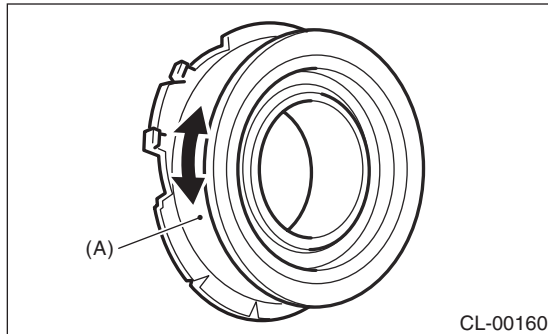

(A) Bearing case

3) Check wear and damage of the bearing case surface in contact with the lever.

2. RELEASE LEVER

Check the pivot portion of the lever and the contact area with the release bearing case for wear.

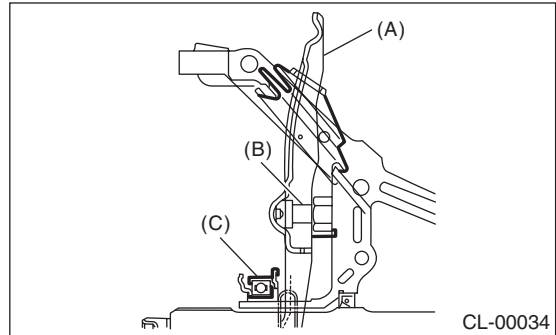

- (A) Release lever
- (B) Pivot
- (C) Release bearing