

9. Automatic Transmission Assembly

A: REMOVAL

- 1) Set the vehicle on a lift.
- 2) Open the front hood and support with the hood stay.
- 3) Disconnect the ground cable from battery.
- 4) Remove the air intake chamber. (Non-turbo model)
<Ref. to IN (H4SO)-6, REMOVAL, Air Intake Chamber.>
- 5) Remove the intercooler. (Turbo model)
<Ref. to IN(H4DOTC)-11, REMOVAL, Intercooler.>
- 6) Remove the air cleaner case stay. (Non-turbo model)

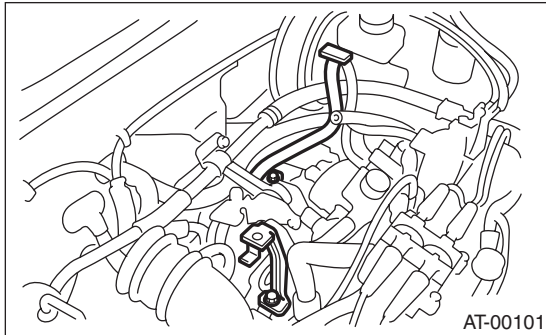

- 7) Disconnect the following connectors.
 - (1) Transmission harness connectors

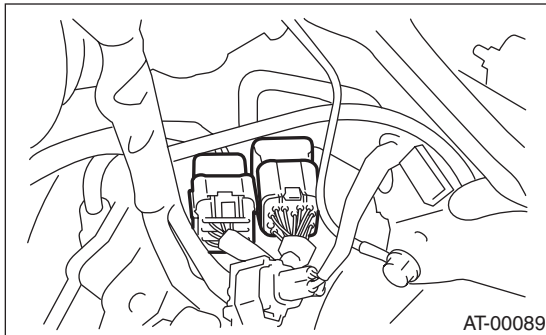

- (2) Transmission ground terminal

- 8) Remove the starter.
<Ref. to SC (H4SO)-6, REMOVAL, Starter.>
- 9) Remove the pitching stopper.

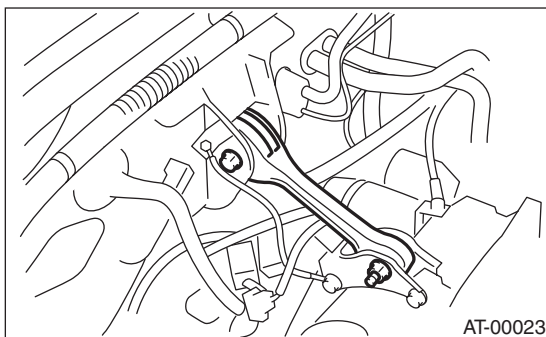

- 10) Separate the torque converter clutch assembly from drive plate.

CAUTION:

- Be careful not to damage attachment bolts.
- Be careful not to drop bolts into the converter case.

- (1) Remove the V-belt covers.
- (2) Remove the service hole plug.
- (3) Remove the bolts which hold torque converter clutch assembly to drive plate.
- (4) Remove all the bolts by gradually rotating the crank sprocket to the same direction as the engine rotates.

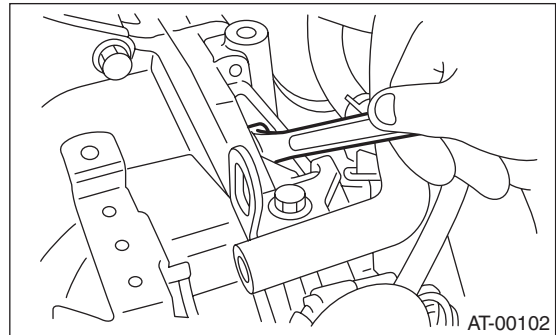

- 11) Install the ST to the converter case.
ST 498277200 STOPPER SET

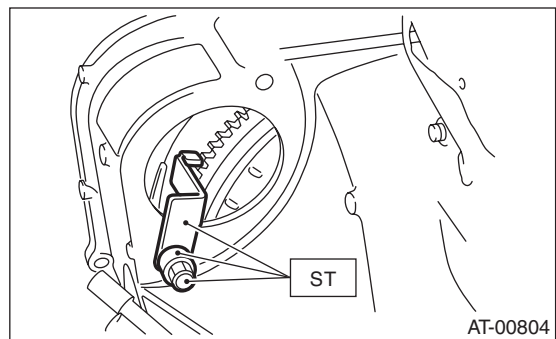

- 12) Remove the ATF level gauge.

NOTE:

Plug the opening to prevent entry of foreign particles into transmission fluid.

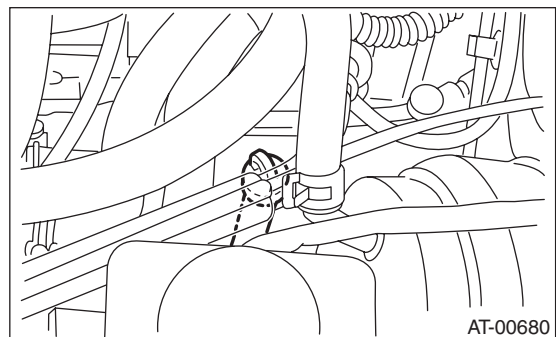

- 13) Remove the throttle body.
<Ref. to FU(H4SO)-12, REMOVAL, Throttle Body.>
- 14) Remove the pitching stopper bracket.

Automatic Transmission Assembly

AUTOMATIC TRANSMISSION

- 15) Set the ST.
ST 41099AC000 ENGINE SUPPORT ASSY

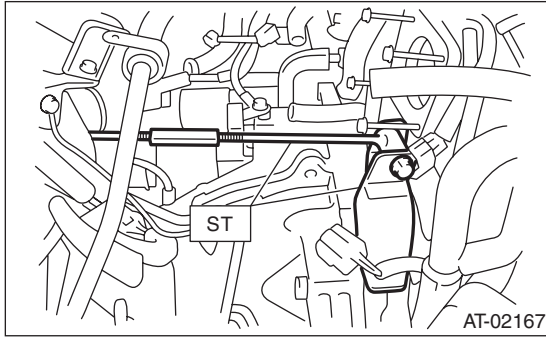

- 16) Remove the bolts which hold right upper side of transmission to engine.

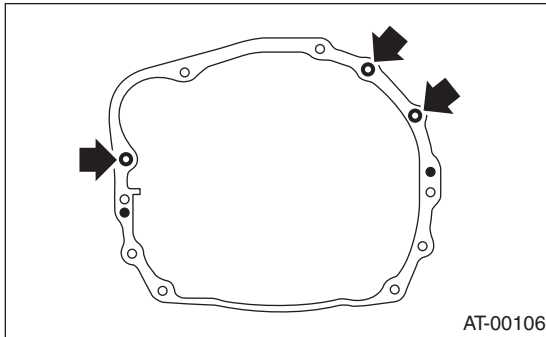

- 17) Lift-up the vehicle.
18) Remove the under cover.
19) Remove the front, center and rear exhaust pipes and the muffler. (Non-turbo model)
<Ref. to EX (H4SO)-4, REMOVAL, Front Exhaust Pipe.> <Ref. to EX (H4SO)-8, REMOVAL, Rear Exhaust Pipe.> <Ref. to EX (H4SO)-9, REMOVAL, Muffler.>
20) Remove the center and rear exhaust pipes and the muffler. (Turbo model)
<Ref. to EX(H4DOTC)-8, REMOVAL, Center Exhaust Pipe.> <Ref. to EX(H4DOTC)-13, REMOVAL, Rear Exhaust Pipe.> <Ref. to EX(H4DOTC)-15, REMOVAL, Muffler.>
21) Remove the drain plug (ATF) to drain ATF.

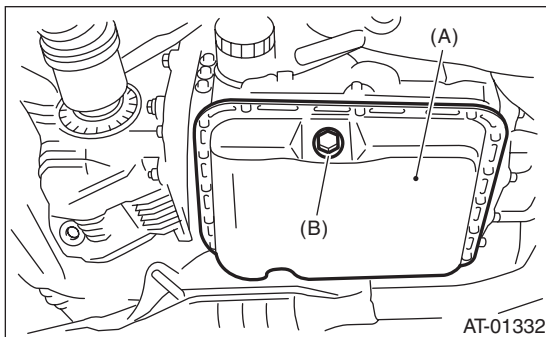

- (A) Oil pan
(B) Drain plug (ATF)

- 22) Disconnect the ATF cooler hoses from the pipes of transmission side, and remove the ATF level gauge guide.

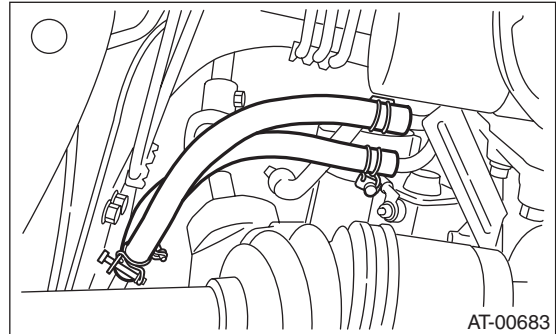

- 23) Remove the propeller shaft.
<Ref. to DS-12, REMOVAL, Propeller Shaft.>
24) Remove the shift select cable.
<Ref. to CS-25, REMOVAL, Select Cable.>
25) Disconnect the stabilizer link from the transverse link.

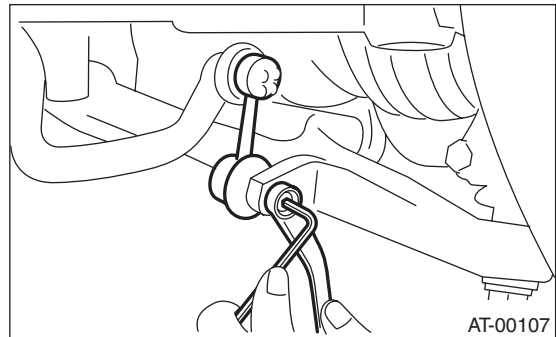

- 26) Remove the bolt securing ball joint of the transverse link to housing.

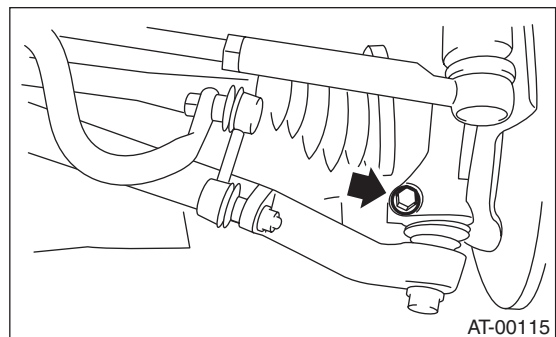

Automatic Transmission Assembly

AUTOMATIC TRANSMISSION

27) Pull out the front drive shaft from the transmission.

(1) Face the letters "AT" on the ST to the transmission side.

ST 28399SA000 DRIVE SHAFT REMOVER

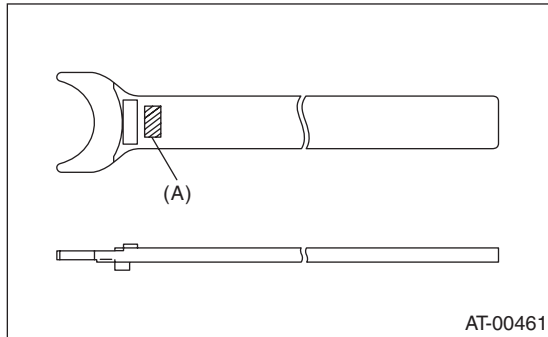

(A) Letters "AT"

(2) Insert the ST between the transmission and front drive shaft.

NOTE:

Set the protrusion of the ST to the torque converter clutch housing.

ST 28399SA000 DRIVE SHAFT REMOVER

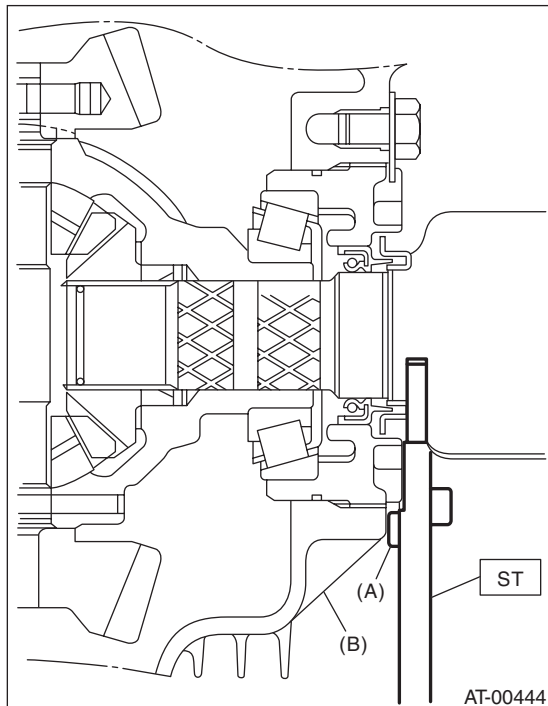

(A) Protrusion of the ST

(B) Converter case

(3) Hold the joint portion (AARi) of the front drive shaft by hand and extract the housing from the transmission by pressing it outside.

28) Remove the bolts which secure the housing cover.

29) Remove the bolts and nuts which hold lower side of transmission to engine.

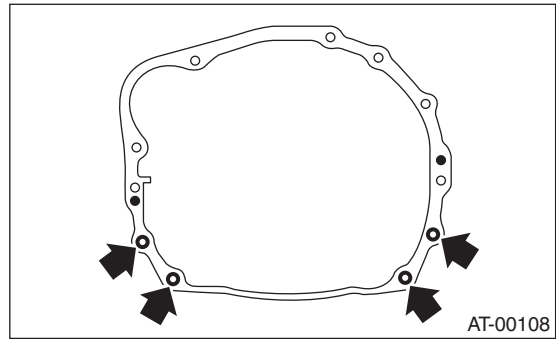

30) Place a transmission jack below the transmission.

NOTE:

Make sure that the support plates of transmission jack do not touch the oil pan.

31) Remove the transmission rear crossmember from the vehicle.

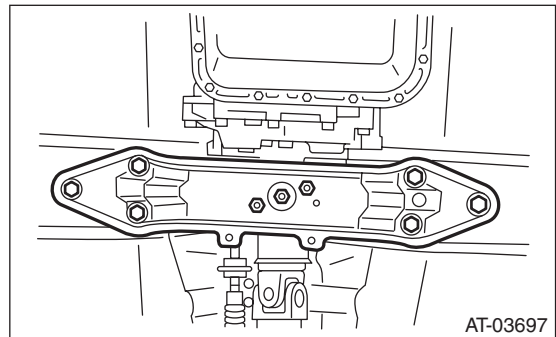

32) While lowering the transmission jack gradually, fully retract the engine support, and then tilt the engine rearward.

33) Remove the transmission.

NOTE:

Remove the transmission and torque converter as a single unit from engine.

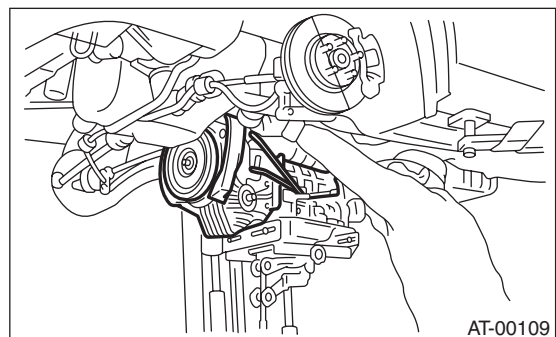

34) Remove the rear cushion rubber from transmission.

Automatic Transmission Assembly

AUTOMATIC TRANSMISSION

B: INSTALLATION

- 1) Replace the differential side oil seal with a new one. <Ref. to 4AT-46, REPLACEMENT, Differential Side Retainer Oil Seal.>
- 2) Install the rear cushion rubber to the transmission.

Tightening torque:

39 N·m (4.0 kgf·m, 29 ft·lb)

- 3) Install the ST to the converter case.
ST 498277200 STOPPER SET

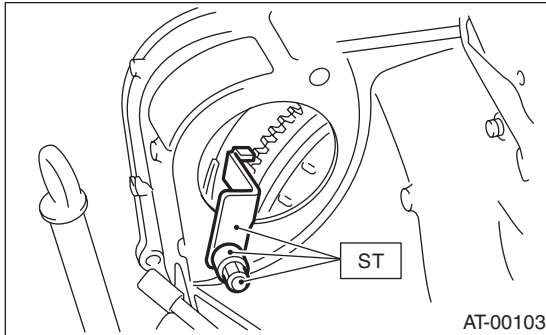

- 4) Install the transmission onto the engine.
(1) Lift-up the transmission gradually using transmission jack.

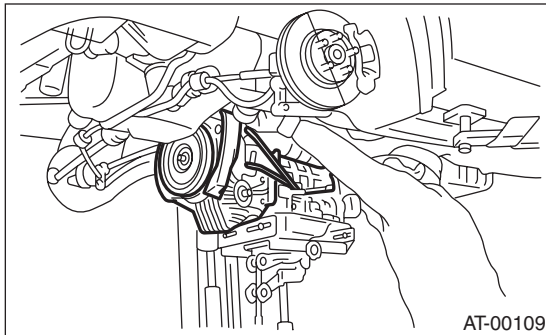

- (2) Insert the stud bolt on the engine side into the transmission bolt hole.
- (3) While lowering the transmission jack gradually, turn the screw of engine support, and then tilt the engine forward to join them together.

- 5) Install the transmission rear crossmember.

Tightening torque:

T1: 35 N·m (3.6 kgf·m, 26 ft·lb)

T2: 70 N·m (7.1 kgf·m, 51 ft·lb)

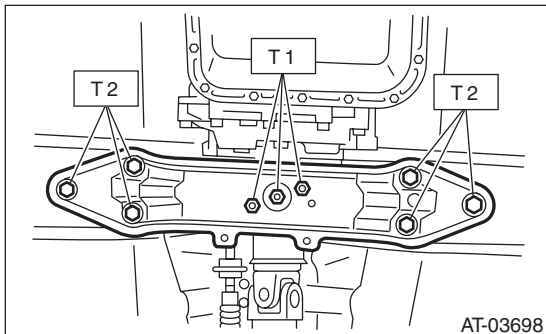

- 6) Remove the transmission jack.
- 7) Tighten the bolts and nuts which hold lower side of transmission to engine.

Tightening torque:

50 N·m (5.1 kgf·m, 36.9 ft·lb)

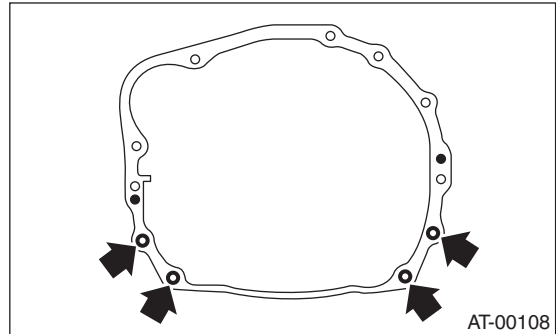

- 8) Tighten the bolt of the housing cover.
- 9) Lower the lift.
- 10) Connect the engine and transmission.
(1) Remove the ST from converter case.

NOTE:

When removing the ST, be careful not to drop it into converter case.

ST 498277200 STOPPER SET

- (2) Tighten the bolts which hold the right upper side of the transmission to engine.

Tightening torque:

50 N·m (5.1 kgf·m, 36.9 ft·lb)

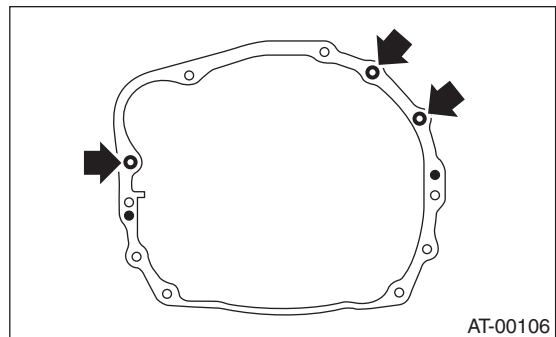

11) Install the torque converter clutch assembly to the drive plate.

CAUTION:

- Be careful not to damage attachment bolts.
- Be careful not to drop bolts into the converter case.

- (1) Tighten the bolts which hold torque converter clutch assembly to the drive plate.
- (2) Tighten all the bolts by gradually rotating the crank sprocket to the same direction as the engine rotates.

Tightening torque:

25 N·m (2.5 kgf-m, 18.1 ft-lb)

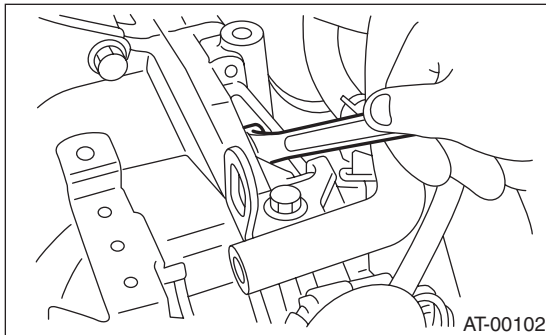

(3) Fit the plug to service hole.

12) Install the starter.

<Ref. to SC (H4SO)-6, INSTALLATION, Starter.>

13) Remove the ST.

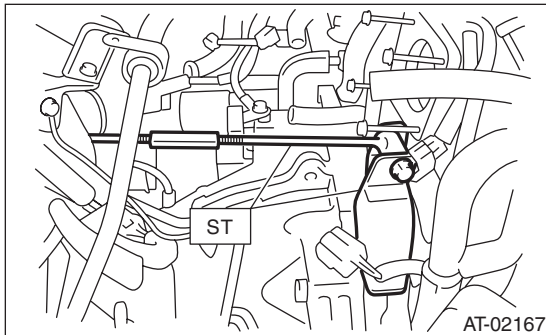

14) Install the pitching stopper bracket.

Tightening torque:

41 N·m (4.2 kgf-m, 30.4 ft-lb)

15) Install the throttle body.

<Ref. to FU(H4SO)-12, INSTALLATION, Throttle Body.>

16) Attach the pitching stopper.

Tightening torque:

T1: 50 N·m (5.1 kgf-m, 37 ft-lb)

T2: 58 N·m (5.9 kgf-m, 43 ft-lb)

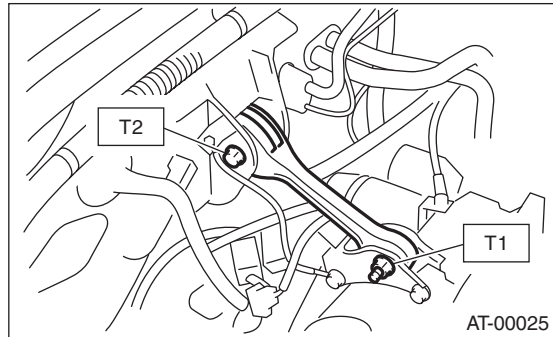

17) Lift-up the vehicle.

18) Replace the circlip of the front drive shaft with a new one.

19) Apply grease to the oil seal lip.

20) Install the ST to side retainer.

ST 28399SA010 OIL SEAL PROTECTOR

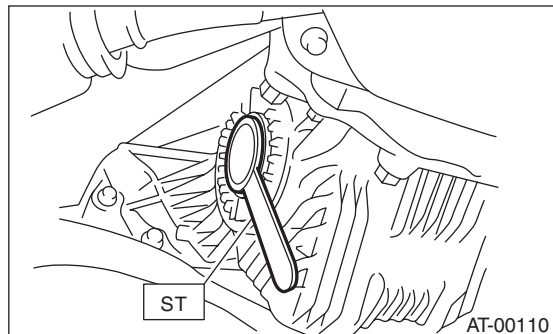

21) Align the spline portion of front drive shaft with the serration of the differential bevel gear to insert, and remove the ST.

ST 28399SA010 OIL SEAL PROTECTOR

22) Insert the front drive shaft into transmission securely by pressing the front housing.

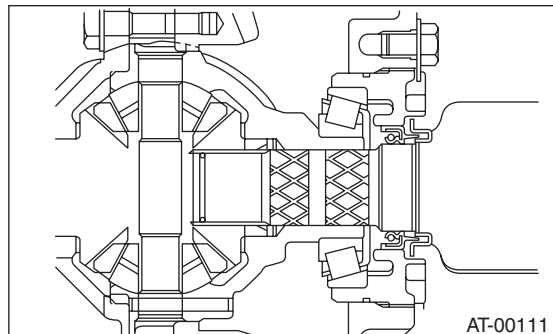

23) Connect the ball joint to the front housing.

Automatic Transmission Assembly

AUTOMATIC TRANSMISSION

24) Tighten the attachment bolts.

Tightening torque:

49 N·m (5.0 kgf·m, 36 ft·lb)

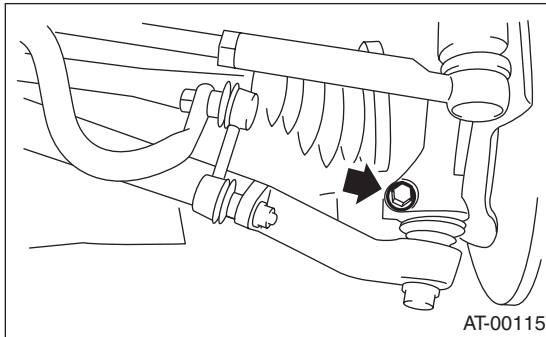

25) Attach the stabilizer link to the transverse link.

Tightening torque:

45 N·m (4.6 kgf·m, 33.2 ft·lb)

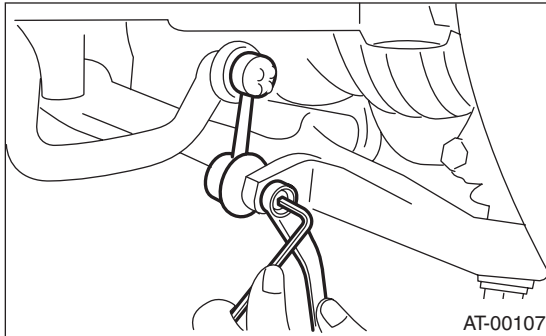

26) Install the shift select cable onto select lever.
<Ref. to CS-26, INSTALLATION, Select Cable.>

27) Connect the ATF cooler hoses to the pipe.

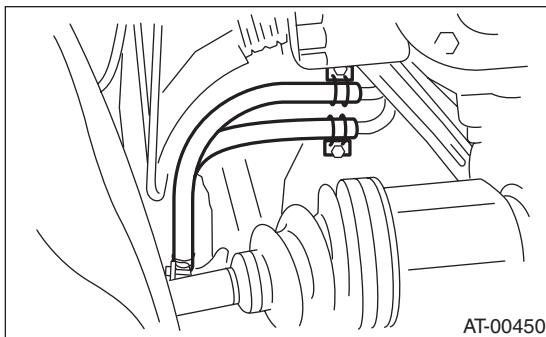

28) Install the ATF level gauge guide.

29) Install the propeller shaft.

<Ref. to DS-13, INSTALLATION, Propeller Shaft.>

30) Install the rear exhaust pipe and muffler assembly.

(Non-turbo model)

<Ref. to EX (H4SO)-8, INSTALLATION, Rear Exhaust Pipe.> <Ref. to EX (H4SO)-9, INSTALLATION, Muffler.>

(Turbo model)

<Ref. to EX(H4DOTC)-14, INSTALLATION, Rear Exhaust Pipe.> <Ref. to EX(H4DOTC)-15, INSTALLATION, Muffler.>

31) Install the front and center exhaust pipe. (Non-turbo model)

<Ref. to EX (H4SO)-5, INSTALLATION, Front Exhaust Pipe.>

32) Install the center exhaust pipe. (Turbo model)
<Ref. to EX(H4DOTC)-9, INSTALLATION, Center Exhaust Pipe.>

33) Install the under cover.

34) Lower the lift.

35) Install the ATF level gauge.

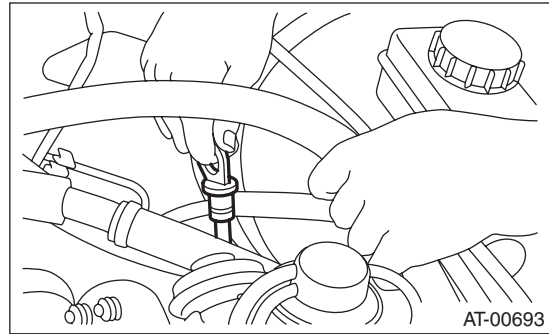

36) Connect the following connectors.

(1) Transmission harness connectors

(2) Transmission ground terminal

37) Install the air cleaner case stay. (Non-turbo model)

Tightening torque:

16 N·m (1.6 kgf·m, 11.6 ft·lb)

38) Install the air intake chamber. (Non-turbo model)

<Ref. to IN (H4SO)-6, INSTALLATION, Air Intake Chamber.>

39) Install the intercooler. (Turbo model)

<Ref. to IN(H4DOTC)-11, INSTALLATION, Intercooler.>

40) Connect the ground cable to the battery.

41) Pour ATF from the oil charge pipe. <Ref. to 4AT-28, Automatic Transmission Fluid.>

42) Check the ATF level. <Ref. to 4AT-28, Automatic Transmission Fluid.>

43) Lower the vehicle from lift.

44) Check the select lever operation.

<Ref. to 4AT-47, INSPECTION, Inhibitor Switch.>

45) Execute the learning control promotion.

<Ref. to 4AT(D)(diag)-15, FACILITATION OF LEARNING CONTROL, OPERATION, Subaru Select Monitor.>

46) Perform the road test.

<Ref. to 4AT-31, Road Test.>