

14. Front Vehicle Speed Sensor

A: REMOVAL

- 1) Set the vehicle on a lift.
- 2) Disconnect the ground cable from battery.
- 3) Remove the air intake chamber. (Non-turbo model)
<Ref. to IN (H4SO)-6, REMOVAL, Air Intake Chamber.>
- 4) Remove the intercooler. (Turbo model)
<Ref. to IN(H4DOTC)-11, REMOVAL, Intercooler.>
- 5) Disconnect the transmission connector.

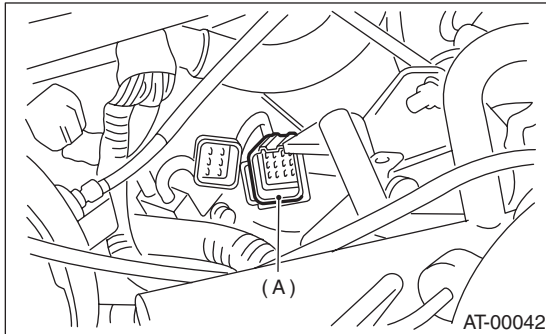

(A) Transmission connector

- 6) Remove the pitching stopper. <Ref. to 4AT-43, REMOVAL, Transmission Mounting System.>
- 7) Remove the transmission connector from stay.
- 8) Lift-up the vehicle.
- 9) Clean the transmission exterior.
- 10) Drain the ATF completely.

NOTE:

Tighten the drain plug (ATF) after draining the ATF.

Tightening torque:

25 N·m (2.5 kgf-m, 18.1 ft-lb)

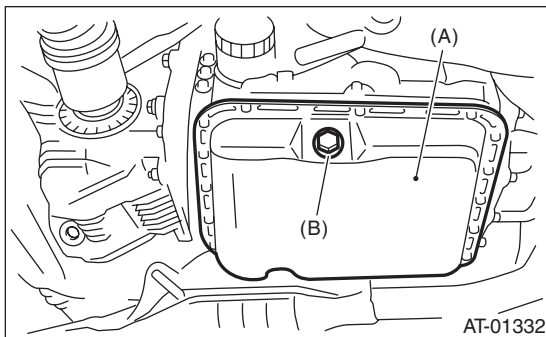

- (A) Oil pan
- (B) Drain plug (ATF)
- (C) Differential gear oil drain plug

- 11) Remove the front, center and rear exhaust pipes and the muffler. (Non-turbo model)
<Ref. to EX (H4SO)-4, REMOVAL, Front Exhaust Pipe.> <Ref. to EX (H4SO)-8, REMOVAL, Rear Exhaust Pipe.> <Ref. to EX (H4SO)-9, REMOVAL, Muffler.>
- 12) Remove the center and rear exhaust pipes and the muffler. (Turbo model)
<Ref. to EX(H4DOTC)-8, REMOVAL, Center Exhaust Pipe.> <Ref. to EX(H4DOTC)-13, REMOVAL, Rear Exhaust Pipe.> <Ref. to EX(H4DOTC)-15, REMOVAL, Muffler.>
- 13) Remove the propeller shaft. <Ref. to DS-12, REMOVAL, Propeller Shaft.>
- 14) Place the transmission jack under the transmission.

NOTE:

Make sure that the support plate of transmission jack does not touch the oil pan.

- 15) Remove the transmission rear crossmember bolt.

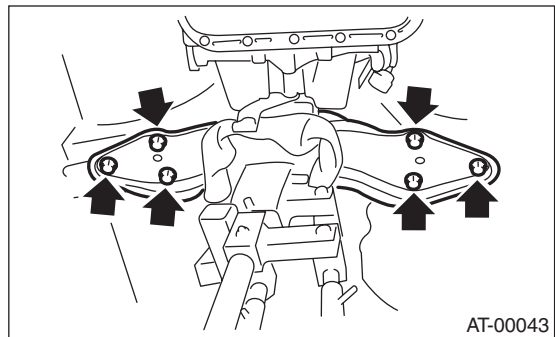

- 16) Lower the transmission jack.

NOTE:

Do not separate the transmission jack and transmission.

- 17) Remove the ATF cooler inlet and outlet pipes.

NOTE:

When removing the outlet pipe, do not lose the ball and spring used with retaining screw.

- 18) Remove the front vehicle speed sensor and torque converter turbine speed sensor.

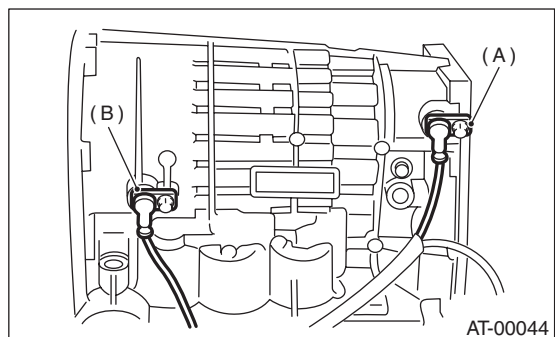

- (A) Front vehicle speed sensor
- (B) Torque converter turbine speed sensor

Front Vehicle Speed Sensor

AUTOMATIC TRANSMISSION

19) Disconnect the connector from the rear vehicle speed sensor.

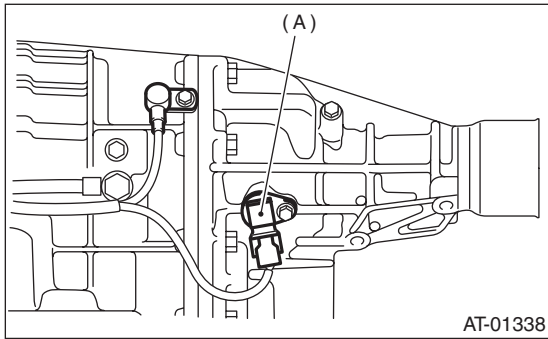

(A) Rear vehicle speed sensor

20) Remove the oil pan.

21) Disconnect the control valve connector and the grounding cable.

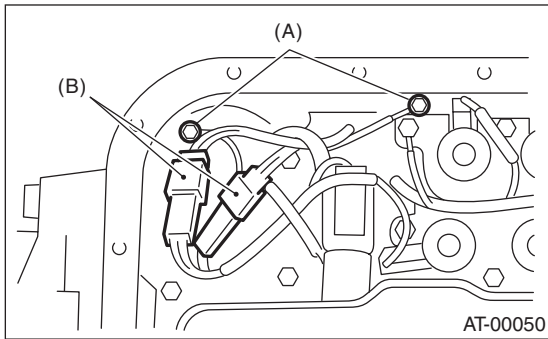

(A) Transmission ground cable
(B) Control valve connector

22) Remove the transmission harness assembly.

B: INSTALLATION

1) Pass the transmission harness assembly through the hole in transmission case.

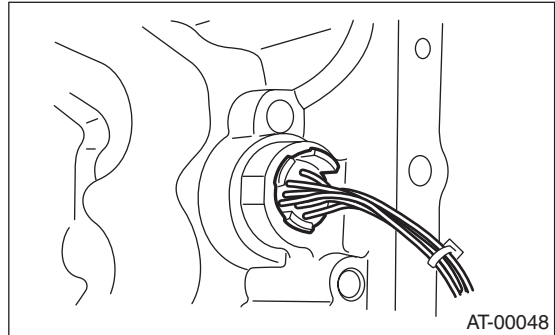

2) Connect the control valve connector and the grounding cable.

Tightening torque:

8 N·m (0.8 kgf·m, 5.8 ft·lb)

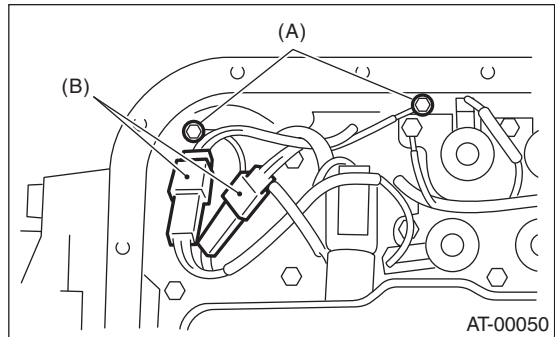

(A) Transmission ground cable
(B) Control valve connector

3) Apply proper amount of liquid gasket to the entire oil pan mating surface.

Liquid gasket:

Three bond 1217B (Part No. K0877YA020) or equivalent

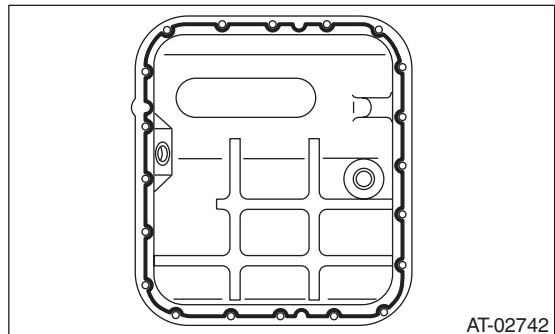

4) Fill the 3 holes aside from the bolt holes in the transmission case, with liquid gasket.

Liquid gasket:

Three bond 1217B (Part No. K0877YA020) or equivalent

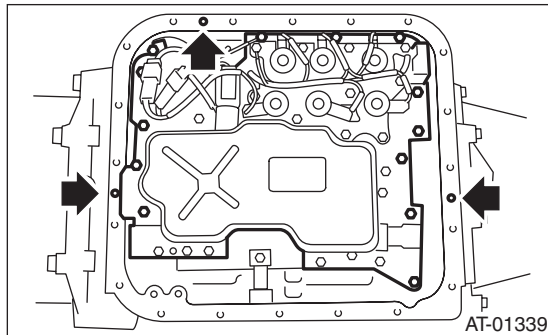

5) Install the oil pan by equally tightening the bolts.

Tightening torque:

5 N·m (0.5 kgf-m, 3.6 ft-lb)

6) Install the front vehicle speed sensor and torque converter turbine speed sensor.

Tightening torque:

7 N·m (0.7 kgf-m, 5.1 ft-lb)

7) Connect the connector to the rear vehicle speed sensor.

8) Install the ATF cooler inlet and outlet pipes.

NOTE:

Use a new copper washer.

Tightening torque:

T1: 25 N·m (2.5 kgf-m, 18.1 ft-lb)

T2: 40 N·m (4.1 kgf-m, 29.5 ft-lb)

T3: 45 N·m (4.6 kgf-m, 33.2 ft-lb)

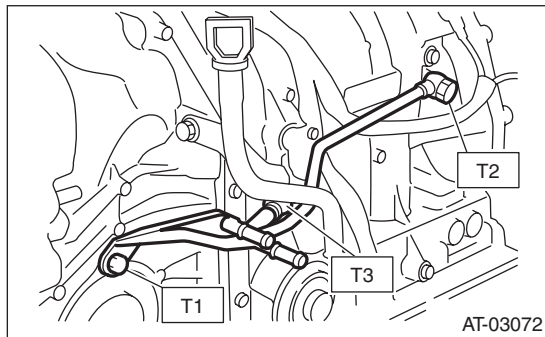

9) Install the transmission rear crossmember bolt.

Tightening torque:

70 N·m (7.1 kgf-m, 51 ft-lb)

10) Install the propeller shaft. <Ref. to DS-13, INSTALLATION, Propeller Shaft.>

11) Install the front, center and rear exhaust pipes, and the muffler. (Non-turbo model)

<Ref. to EX (H4SO)-5, INSTALLATION, Front Exhaust Pipe.> <Ref. to EX (H4SO)-8, INSTALLATION, Rear Exhaust Pipe.> <Ref. to EX (H4SO)-9, INSTALLATION, Muffler.>

12) Install the center, rear exhaust pipes and the muffler. (Turbo model)

<Ref. to EX(H4DOTC)-9, INSTALLATION, Center Exhaust Pipe.> <Ref. to EX(H4DOTC)-14, INSTALLATION, Rear Exhaust Pipe.> <Ref. to EX(H4DOTC)-15, INSTALLATION, Muffler.>

13) Lower the vehicle.

14) Install the transmission connector to the stay.
15) Attach the pitching stopper. <Ref. to 4AT-43, INSTALLATION, Transmission Mounting System.>

16) Install the air intake chamber. (Non-turbo model)

<Ref. to IN (H4SO)-6, INSTALLATION, Air Intake Chamber.>

17) Install the intercooler. (Turbo model)

<Ref. to IN(H4DOTC)-11, INSTALLATION, Intercooler.>

18) Pour in ATF.

<Ref. to 4AT-28, Automatic Transmission Fluid.>

19) Bleed the air of control valve.

<Ref. to 4AT-59, Air Bleeding of Control Valve.>

20) Check the level and leaks of the ATF.

<Ref. to 4AT-28, Automatic Transmission Fluid.>

21) Execute the learning control promotion.

<Ref. to 4AT(D)(diag)-15, FACILITATION OF LEARNING CONTROL, OPERATION, Subaru Select Monitor.>