

Extension Case

AUTOMATIC TRANSMISSION

25.Extension Case

A: REMOVAL

- 1) Remove the transmission assembly.
<Ref. to 4AT-37, REMOVAL, Automatic Transmission Assembly.>
- 2) Remove the rear vehicle speed sensor.

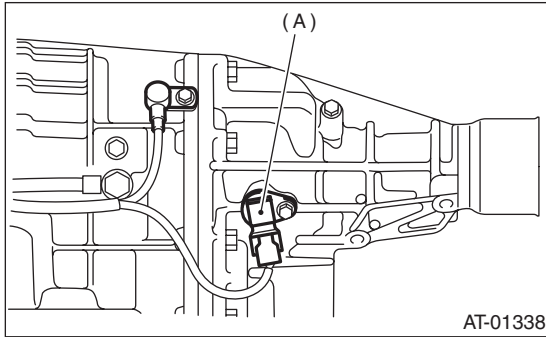

(A) Rear vehicle speed sensor

- 3) Separate the transmission case and extension case section.

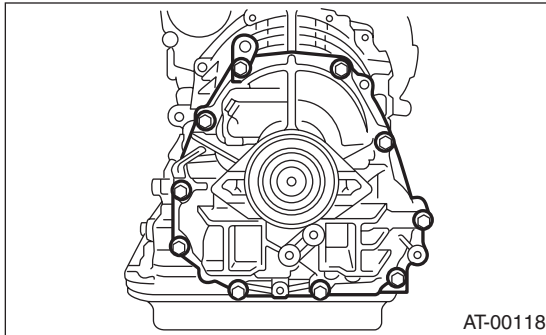

B: INSTALLATION

- 1) Apply vaseline to the selected thrust needle bearing, and install to the reduction drive gear end surface. <Ref. to 4AT-76, ADJUSTMENT, Transfer Clutch.>

NOTE:

Install the thrust needle bearing in the correct direction.

- 2) Install a new gasket.
- 3) Install the extension case to transmission case.
- 4) Tighten bolts to secure the extension case.

Tightening torque:

25 N·m (2.5 kgf-m, 18.1 ft-lb)

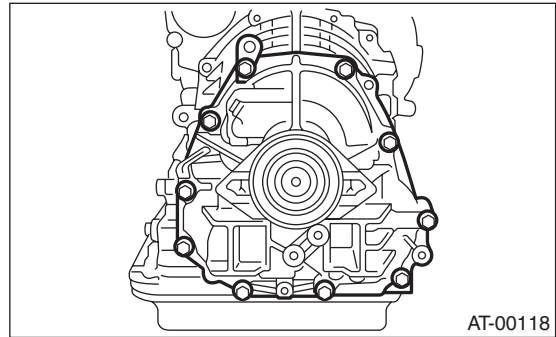

- 5) Install the rear vehicle speed sensor.

Tightening torque:

7 N·m (0.7 kgf-m, 5.1 ft-lb)

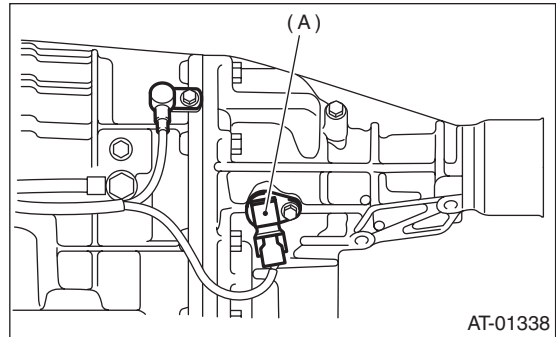

(A) Rear vehicle speed sensor

- 6) Install the transmission assembly.
<Ref. to 4AT-40, INSTALLATION, Automatic Transmission Assembly.>

C: DISASSEMBLY

1. MP-T MODEL

1) Take out the transfer clutch assembly by lightly tapping the end of rear drive shaft with a plastic hammer.

NOTE:

Be careful not to damage the oil seal of the extension.

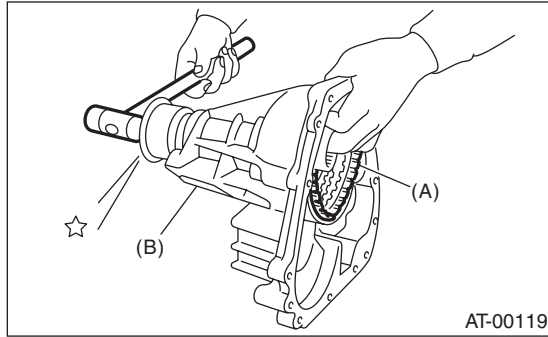

- (A) Extension case
- (B) Transfer clutch assembly

2) Remove the transfer clutch pipe without bending the pipe.

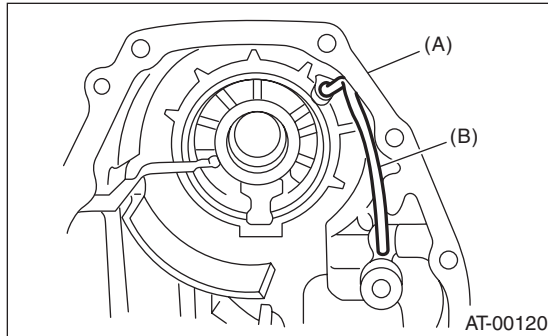

- (A) Extension case
- (B) Transfer clutch pipe

- 3) Remove the dust cover from extension case.
- 4) Remove the oil seal from the extension case.

2. VTD MODEL

1) Extract the circlip with ST1, ST2 and ST3 and the press.

- ST1 398673600 COMPRESSOR
- ST2 498627100 SEAT
- ST3 398663600 PLIERS

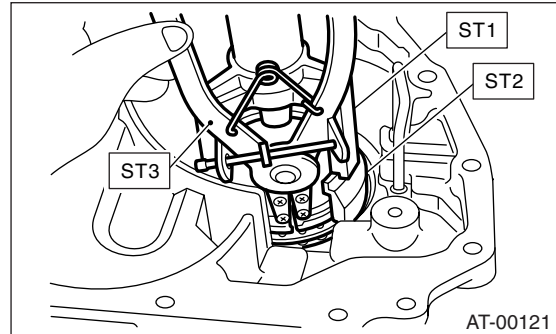

2) Remove the test plug.

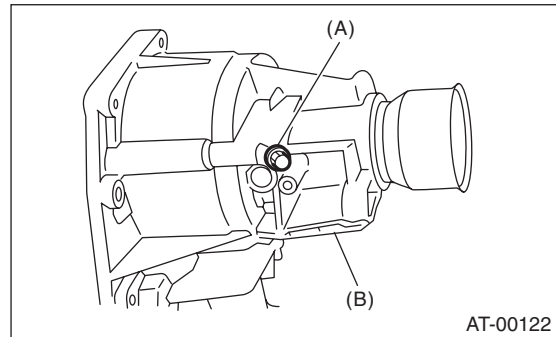

- (A) Test plug
- (B) Extension case

3) Remove the clutch piston using compressed air.

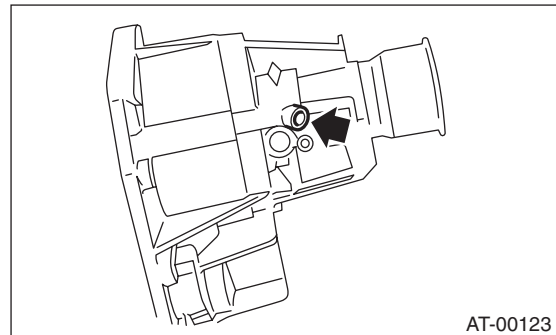

Extension Case

AUTOMATIC TRANSMISSION

- 4) Remove the transfer clutch pipe without bending the pipe.

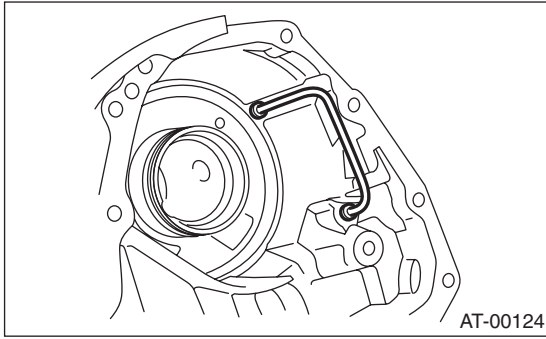

- 5) Remove the dust cover from extension case.
- 6) Remove the oil seal from the extension case.

D: ASSEMBLY

1. MP-T MODEL

- 1) Press-fit the new oil seal using ST and the press. ST 498057300 INSTALLER
- 2) Press-fit the dust cover.
- 3) Install the transfer clutch pipe to the extension case without bending the pipe.

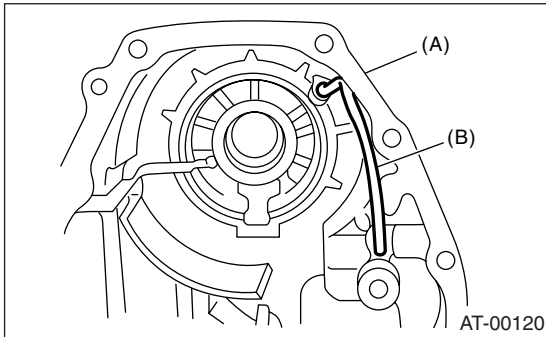

- (A) Extension case
(B) Transfer clutch pipe

- 4) Install the transfer clutch assembly to the case.

NOTE:

- Be careful not to damage the seal ring.
- Press-fit the transfer clutch assembly to bottom of bearing shoulder completely.

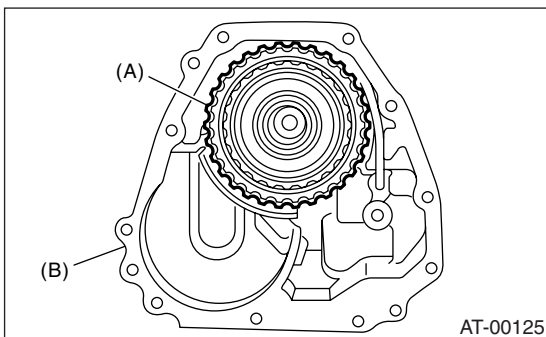

- (A) Transfer clutch assembly
(B) Extension case

2. VTD MODEL

- 1) Press-fit the new oil seal using ST and the press. ST 498057300 INSTALLER
- 2) Press-fit the dust cover.
- 3) Install the transfer clutch pipe to the extension case without bending the pipe.

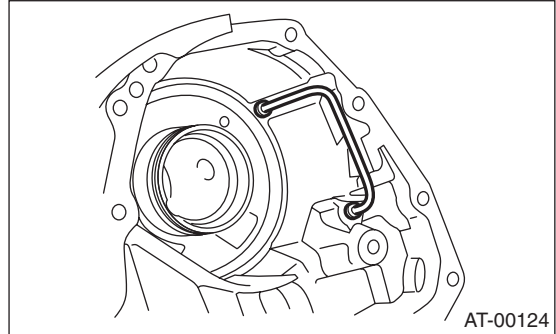

- 4) Install the test plug.

Tightening torque:

13 N·m (1.3 kgf-m, 9.4 ft-lb)

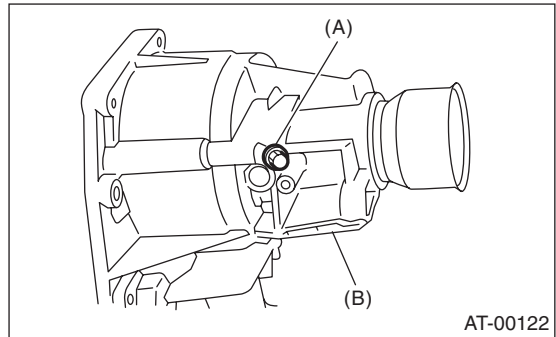

- (A) Test plug
(B) Extension case

- 5) Insert the multi-plate clutch, drive plate, driven plate and spring retainer.

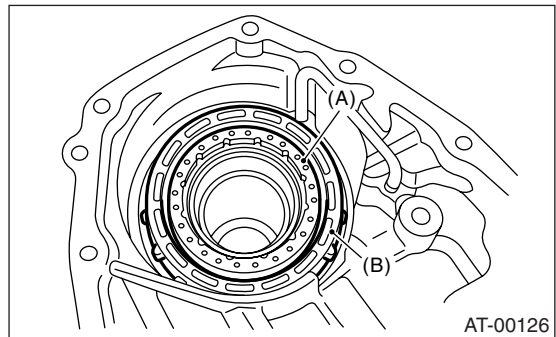

- (A) Spring retainer
(B) Multi-plate clutch (LSD) piston ASSY

6) Install the circlip using ST1, ST2 and ST3.

ST1 398673600 COMPRESSOR

ST2 498627100 SEAT

ST3 398663600 PLIERS

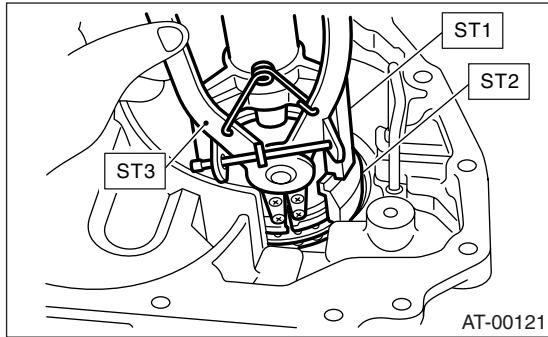

E: INSPECTION

- Use an air compressor to check that the transfer pipe and extension case routes are not clogged and are not leaking.
- Inspect the extension end play, and adjust it to be within the standard value. <Ref. to 4AT-76, ADJUSTMENT, Transfer Clutch.>

(Model with MP-T)

<Ref. to 4AT-76, MP-T MODEL, ADJUSTMENT, Transfer Clutch.>

(Model with VDC)

<Ref. to 4AT-76, VTD MODEL, ADJUSTMENT, Transfer Clutch.>