

Transfer Clutch

AUTOMATIC TRANSMISSION

26. Transfer Clutch

A: REMOVAL

1) Remove the transmission assembly from vehicle body. <Ref. to 4AT-37, REMOVAL, Automatic Transmission Assembly.>

2) Remove the extension case, and take out the transfer clutch assembly. <Ref. to 4AT-68, REMOVAL, Extension Case.> <Ref. to 4AT-69, DISASSEMBLY, Extension Case.>

B: INSTALLATION

1) Select the thrust needle bearing. <Ref. to 4AT-76, ADJUSTMENT, Transfer Clutch.>

2) Install the transfer clutch assembly to the case.

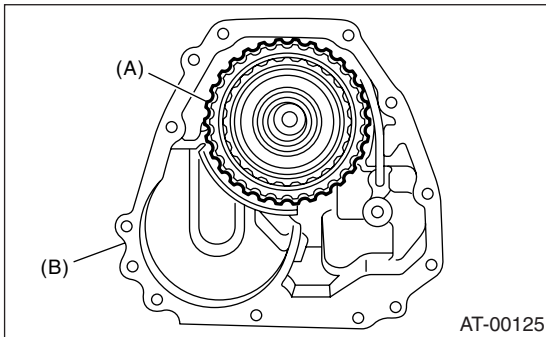

(A) Transfer clutch assembly
(B) Extension case

3) Tighten the bolts to secure the case.

Tightening torque:

25 N·m (2.5 kgf·m, 18.1 ft·lb)

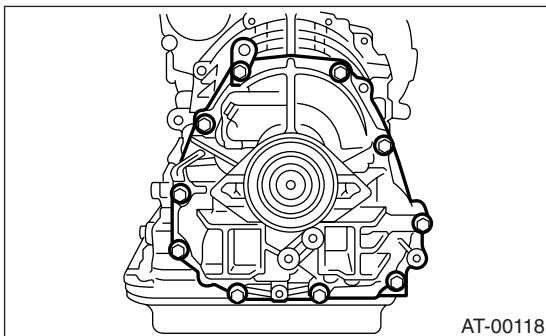

4) Install the transmission assembly to the vehicle. <Ref. to 4AT-40, INSTALLATION, Automatic Transmission Assembly.>

C: DISASSEMBLY

1) Remove the seal ring.

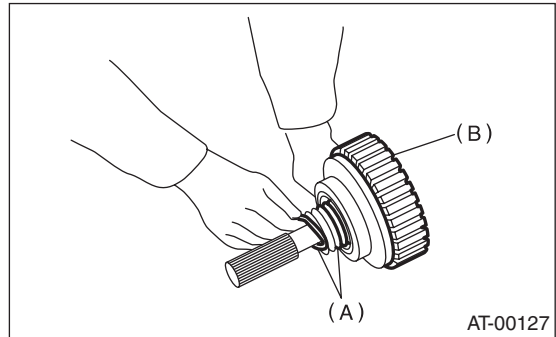

(A) Seal ring
(B) Rear drive shaft

2) Remove the ball bearing using the ST and the press.

ST 498077600 REMOVER

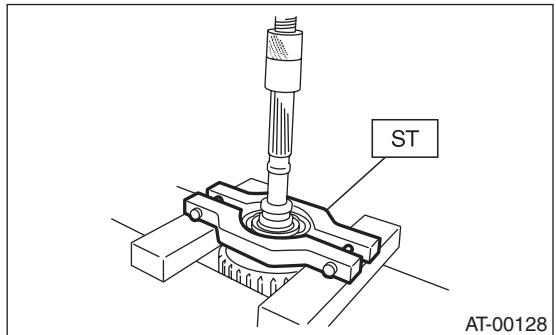

3) Use a flat tip screwdriver to remove the snap ring, and then take out the pressure plate, retaining plate, drive plate and driven plate.

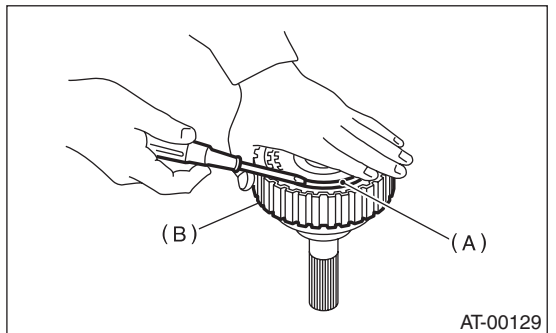

(A) Snap ring
(B) Rear drive shaft

Transfer Clutch

AUTOMATIC TRANSMISSION

4) Using the ST1, ST2 and ST3, remove the snap ring, then take out the return spring and transfer clutch piston seal.

ST1 399893600 PLIERS
ST2 398673600 COMPRESSOR
ST3 398623600 SEAT

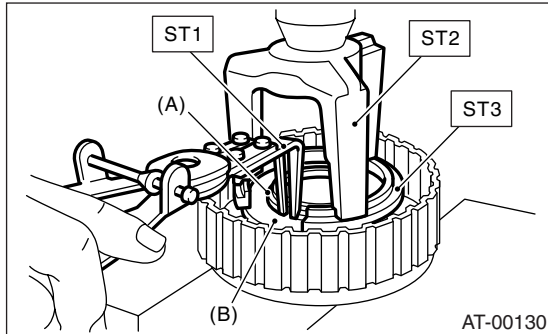

(A) Snap ring
(B) Transfer clutch piston seal

5) Use an air compressor to blow compressed air from the rear drive shaft to remove the transfer clutch piston.

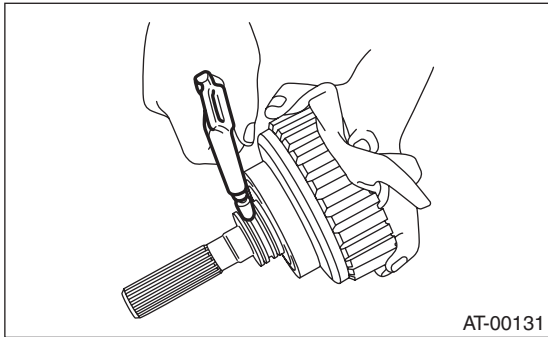

AT-00131

D: ASSEMBLY

1) Install the transfer clutch piston.

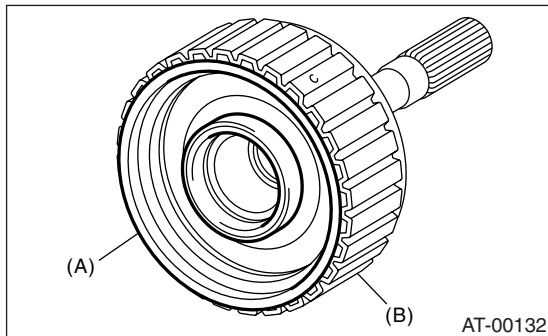

(A) Transfer clutch piston
(B) Rear drive shaft

2) Install the return spring to transfer clutch piston.

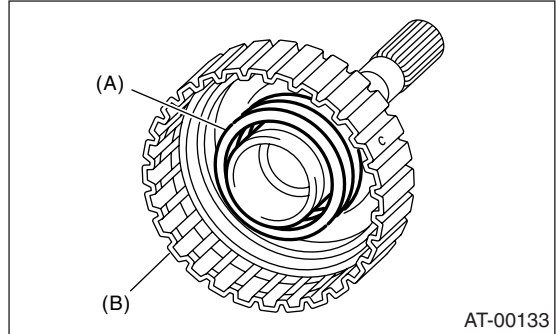

(A) Return spring
(B) Rear drive shaft

3) Install the transfer clutch piston seal.

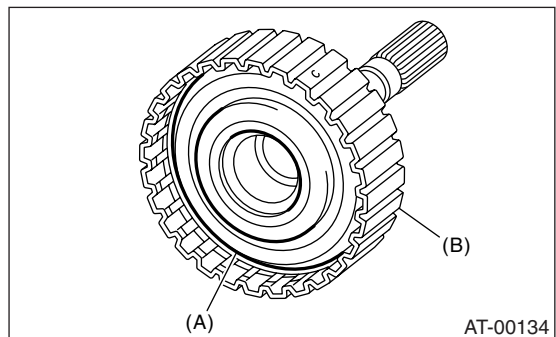

(A) Transfer clutch piston seal
(B) Rear drive shaft

4) Attach the ST to the rear drive shaft.

ST 499257300 SNAP RING OUTER GUIDE

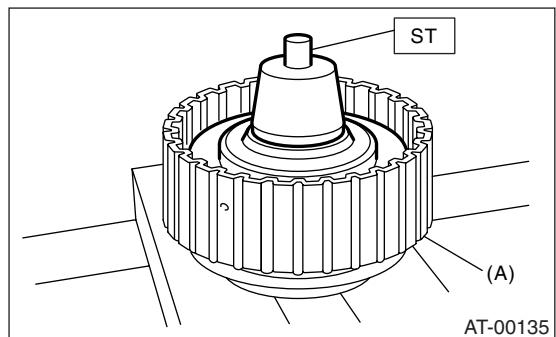

(A) Rear drive shaft

Transfer Clutch

AUTOMATIC TRANSMISSION

5) Install the snap ring to the ST.

ST 499257300 SNAP RING OUTER GUIDE

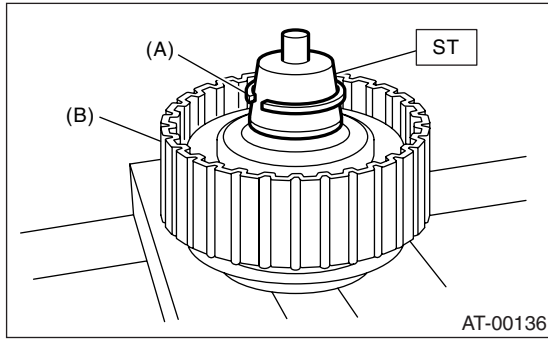

- (A) Snap ring
- (B) Transfer clutch

6) Install the snap ring to the rear drive shaft using ST1 and ST2.

ST1 499257300 SNAP RING OUTER GUIDE

ST2 499247400 INSTALLER

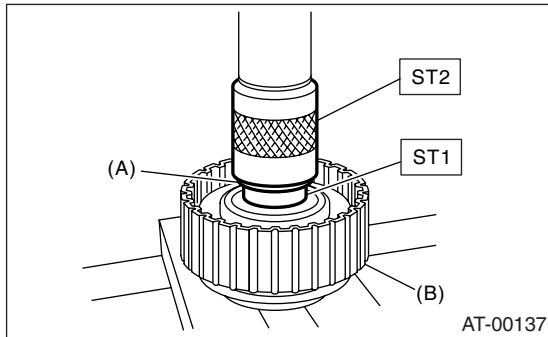

- (A) Snap ring
- (B) Transfer clutch

7) Install the drive plate, driven plate, pressure plate, retaining plate and snap ring.

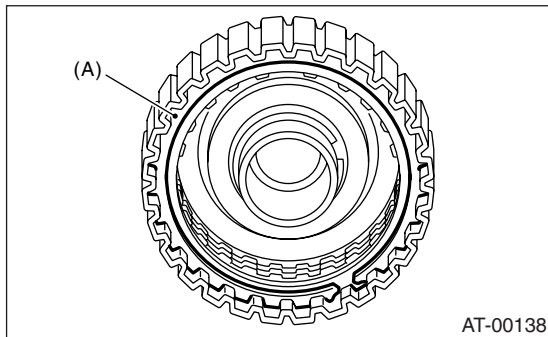

- (A) Snap ring

8) Use an air compressor to apply compressed air to see if the assembled parts move smoothly.

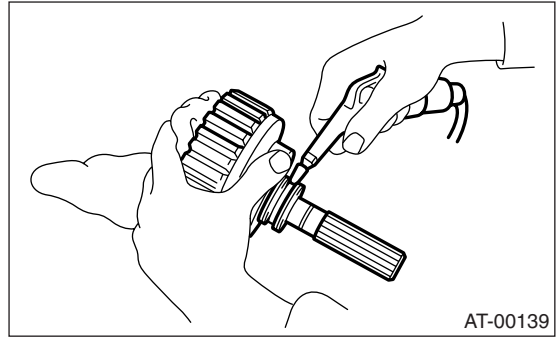

9) Check clearance between the snap ring and pressure plate. <Ref. to 4AT-75, INSPECTION, Transfer Clutch.>

10) Press-fit new ball bearing using ST.

ST 899580100 INSTALLER

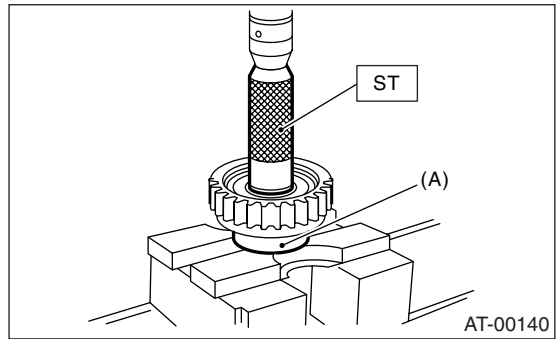

- (A) Ball bearing

11) Apply vaseline to a new seal ring and attach to the seal ring groove of the rear drive shaft.

NOTE:

While installing the seal ring, not to stretch the seal ring excessively.

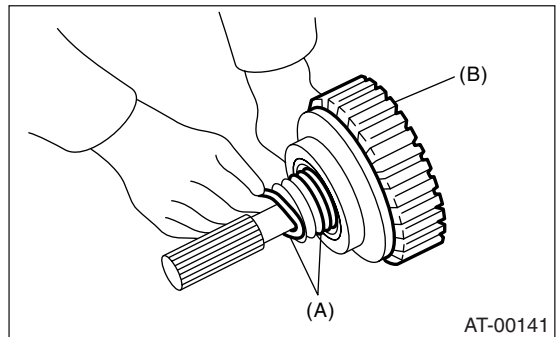

- (A) Seal ring
- (B) Rear drive shaft

12) Install the transfer clutch assembly while taking care not to damage the seal ring.

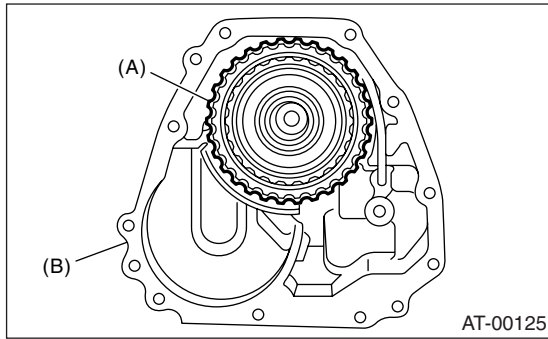

(A) Transfer clutch assembly
(B) Extension case

Limit thickness:
1.6 mm (0.063 in)

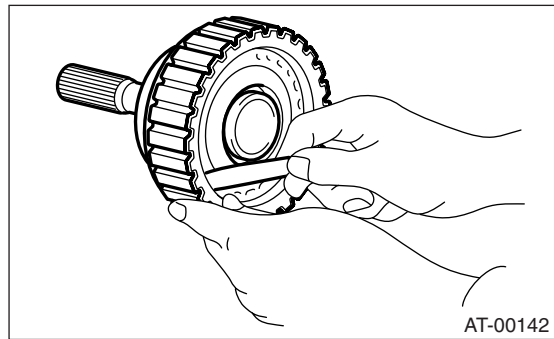

Retaining plate	
Part No.	Thickness mm (in)
31593AA151	3.3 (0.130)
31593AA161	3.7 (0.146)
31593AA171	4.1 (0.161)
31593AA181	4.5 (0.177)

E: INSPECTION

- Inspect the drive plate surface for wear and damage.
- Make sure the snap ring is not worn and the return spring has no permanent distortion, damage, or deformation.
- Inspect the D-ring for damage.
- Inspect the extension end play, and adjust it to be within the standard value.

MP-T MODEL <Ref. to 4AT-76, MP-T MODEL, ADJUSTMENT, Transfer Clutch.>

VTD MODEL <Ref. to 4AT-76, VTD MODEL, ADJUSTMENT, Transfer Clutch.>

- 1) Check clearance between the snap ring and pressure plate.
- 2) Before measuring clearance, place same thickness shims on both sides to prevent the pressure plate from tilting.
- 3) If the clearance exceeds the service limits, replace the driven plate and select and adjust the retaining plate to be within the initial standard value.

Initial standard:

0.7 — 1.1 mm (0.028 — 0.043 in)

4) Check for tight corner braking phenomenon when the vehicle is moved forward with the steering fully turned. If tight corner braking occurs, perform the following procedures.

(1) With the steering wheel held at fully turned position, drive the vehicle in "D" range and with vehicle speed at approx. 5 km/h (3 MPH) in both clockwise and counterclockwise directions for approx. ten times each, while repeating acceleration and braking intermittently.

(2) If the tight corner braking phenomenon still persists, drive the vehicle again in a circle for several laps.

Transfer Clutch

AUTOMATIC TRANSMISSION

F: ADJUSTMENT

1. MP-T MODEL

- 1) Measure the distance "A" from the end of ST to the rear drive shaft using ST.
 ST 398643600 GAUGE

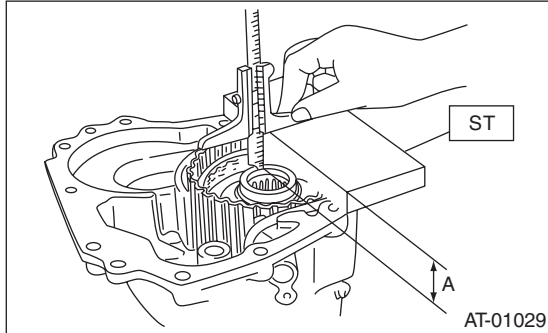

- 2) Measure the distance "B" from the transmission case end to the end of ST using ST1 and ST2.
 ST1 398643600 GAUGE
 ST2 499577000 GAUGE

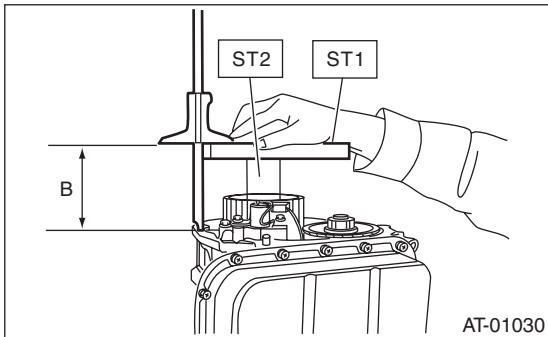

- 3) Calculation formula:

$$T = A - B + 35.4 \text{ mm}$$

$$[T = A - B + 1.3937 \text{ in}]$$

T: Thrust needle bearing thickness

A: Distance from the end of the ST to end of rear drive shaft

B: Distance from the end of the transmission case to the end of the ST

Thrust needle bearing	
Part No.	Thickness mm (in)
806536020	3.8 (0.150)
806535030	4.0 (0.157)
806535040	4.2 (0.165)
806535050	4.4 (0.173)
806535060	4.6 (0.181)
806535070	4.8 (0.189)
806535090	5.0 (0.197)

2. VTD MODEL

- 1) Insert the rear drive shaft into the reduction drive gear and center differential assembly.

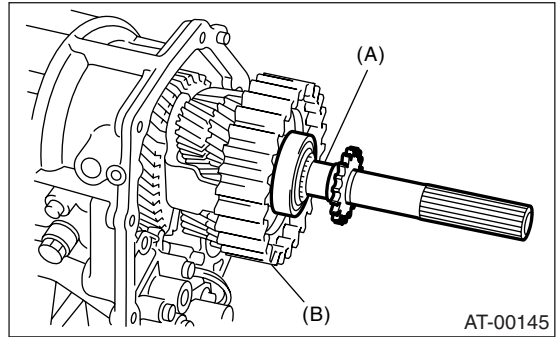

(A) Rear drive shaft

(B) Center differential carrier

- 2) Using the ST, measure the distance "L" from the end of the ST to the rear drive shaft ball bearing outer ring contact surface.
 ST 398643600 GAUGE

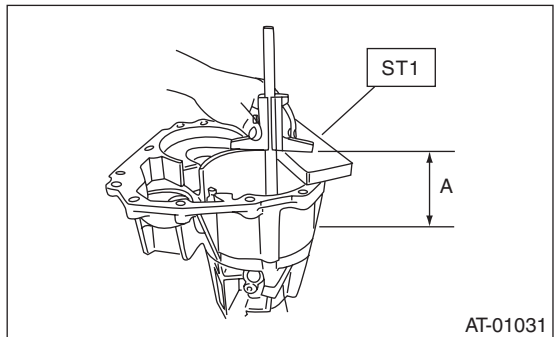

A Measured value

- 3) Measure the distance "B" from the transmission case mating surface to the end surface of the ST using the ST.
 ST 398643600 GAUGE

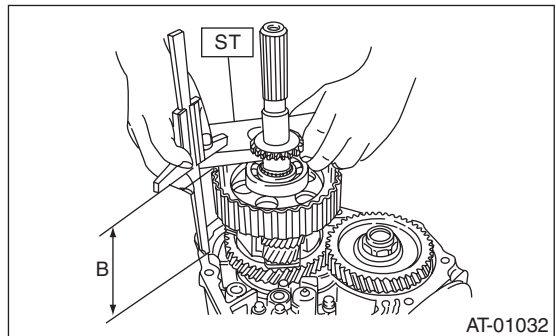

B Measured value

4) Calculation formula:

Calculate "T":

When the clearance is 0.05 mm (0.0020 in), select up to four adjusting shims from the table, according to the clearance value.

When clearance is 0.05 mm (0.0020 in)

$$T = A - B + 0.40 \text{ mm}$$

$$[T = A - B + 0.0157 \text{ in}]$$

When clearance is 0.25 mm (0.0098 in)

$$T = A - B + 0.20 \text{ mm}$$

$$[T = A - B + 0.0079 \text{ in}]$$

T: Shim clearance

A: Distance from the end of extension case to the rear drive shaft ball bearing outer ring contact surface

B: Distance from the end of the transmission case to the end of the ST

T: Shim thickness

0.05 — 0.25 mm (0.0020 — 0.0098 in)

Adjustment shim	
Part No.	Thickness mm (in)
33281AA001	0.2 (0.008)
33281AA011	0.5 (0.020)