

Reduction Driven Gear

AUTOMATIC TRANSMISSION

29.Reduction Driven Gear

A: REMOVAL

1. MP-T MODEL

- 1) Remove the transmission assembly from vehicle body. <Ref. to 4AT-37, REMOVAL, Automatic Transmission Assembly.>
- 2) Remove the rear wheel speed sensor, and separate the extension case from transmission case. <Ref. to 4AT-68, REMOVAL, Extension Case.>
- 3) Set the select lever to "P" range.
- 4) Lift the crimped section, and then remove the lock nut.

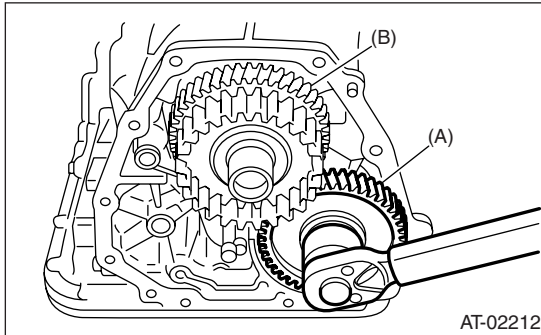

- (A) Reduction driven gear
- (B) Reduction drive gear

- 5) Using the ST1 and ST2, extract the reduction driven gear assembly.

ST1 499737000 PULLER
ST2 899524100 PULLER SET

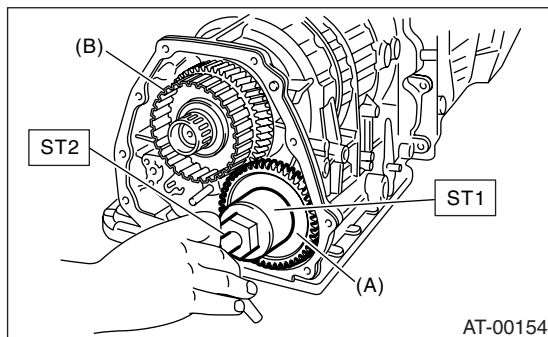

- (A) Reduction driven gear assembly
- (B) Reduction drive gear assembly

2. VTD MODEL

- 1) Remove the transmission assembly from vehicle body. <Ref. to 4AT-37, REMOVAL, Automatic Transmission Assembly.>
- 2) Remove the rear wheel speed sensor, and separate the extension case from transmission case. <Ref. to 4AT-68, REMOVAL, Extension Case.>
- 3) Remove the rear drive shaft. <Ref. to 4AT-79, REMOVAL, Rear Drive Shaft.>
- 4) Set the select lever to "P" range.

- 5) Lift the crimped section, and then remove the lock nut.

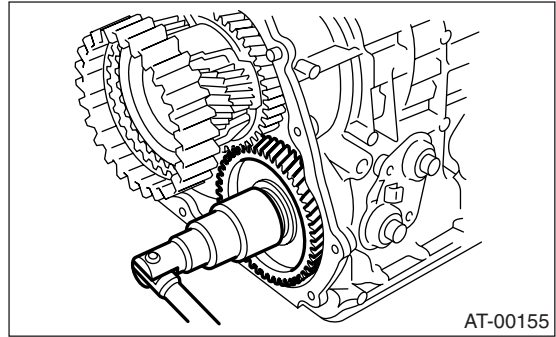

- 6) Using the ST1 and ST2, extract the reduction driven gear.

ST1 499737000 PULLER
ST2 899524100 PULLER SET

- 7) Pull out the center differential assembly. <Ref. to 4AT-84, REMOVAL, Center Differential Carrier.>

B: INSTALLATION

1. MP-T MODEL

- 1) Set the select lever to "P" range.
- 2) Using a plastic hammer, install the reduction driven gear assembly and the new washer, and tighten the new lock nut.

Tightening torque:

100 N·m (10.2 kgf·m, 73.8 ft·lb)

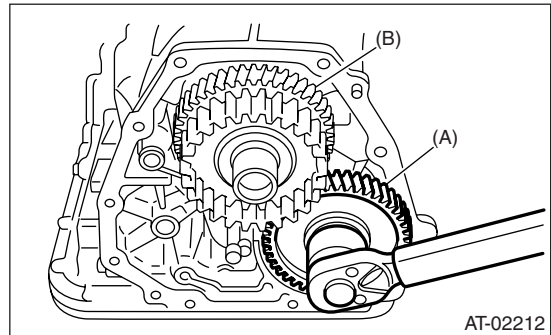

- (A) Reduction driven gear assembly
- (B) Reduction drive gear assembly

- 3) After tightening, stake the lock nut securely.
- 4) Join the transmission case and the extension case, and then install the rear vehicle speed sensor. <Ref. to 4AT-68, INSTALLATION, Extension Case.>
- 5) Install the transmission assembly to the vehicle. <Ref. to 4AT-40, INSTALLATION, Automatic Transmission Assembly.>

2. VTD MODEL

- 1) Set the select lever to "P" range.
- 2) Use a plastic hammer to install reduction driven gear assembly.
- 3) Use a plastic hammer to install the center differential.
- 4) Install new self-locking nut and washer.

Tightening torque:

100 N·m (10.2 kgf-m, 73.8 ft-lb)

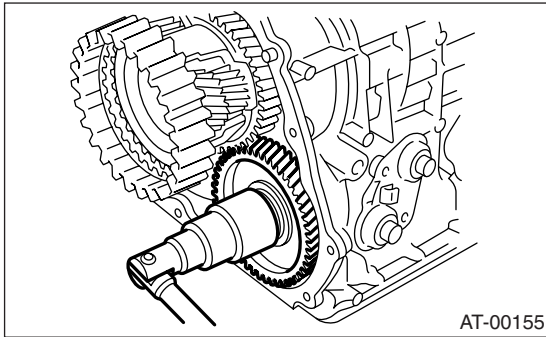

- 5) After tightening, stake the lock nut securely.
- 6) Insert the rear driveshaft assembly. <Ref. to 4AT-79, INSTALLATION, Rear Drive Shaft.>
- 7) Join the transmission case and the extension case, and then install the rear vehicle speed sensor. <Ref. to 4AT-68, INSTALLATION, Extension Case.>
- 8) Install the transmission assembly to the vehicle. <Ref. to 4AT-40, INSTALLATION, Automatic Transmission Assembly.>

C: DISASSEMBLY

- 1) Remove the snap ring from reduction driven gear.

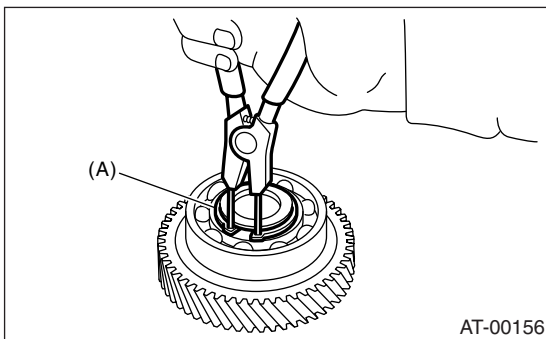

(A) Snap ring

- 2) Remove the ball bearing from reduction driven gear using ST.

ST 498077600 REMOVER

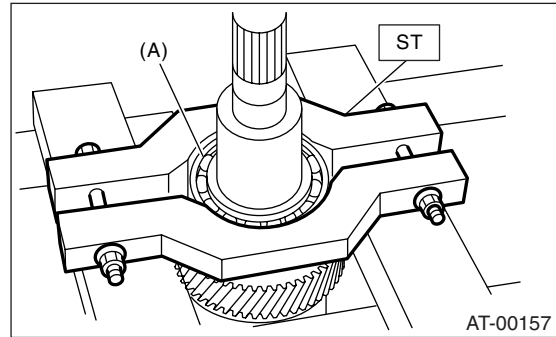

(A) Ball bearing

D: ASSEMBLY

- 1) Install the new ball bearing to reduction driven gear using press.

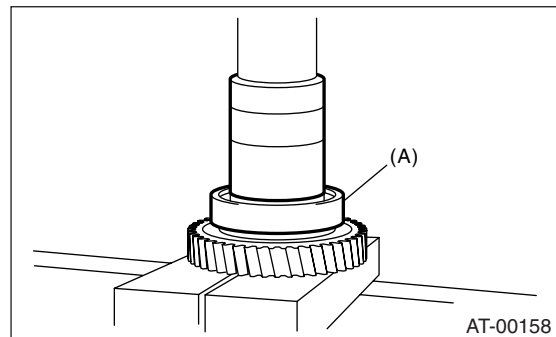

(A) Ball bearing

- 2) Install the snap ring to reduction driven gear.

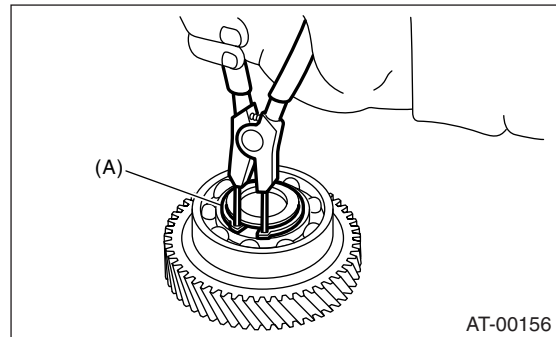

(A) Snap ring

E: INSPECTION

Make sure the ball bearing and gear is not deformed or damaged.