

# Reduction Drive Gear

AUTOMATIC TRANSMISSION

## 30.Reduction Drive Gear

### A: REMOVAL

- 1) Remove the transmission assembly from vehicle body. <Ref. to 4AT-37, REMOVAL, Automatic Transmission Assembly.>
- 2) Remove the rear wheel speed sensor, and separate the extension case from transmission case. <Ref. to 4AT-68, REMOVAL, Extension Case.>
- 3) Remove the reduction driven gear. <Ref. to 4AT-80, REMOVAL, Reduction Driven Gear.>
- 4) Using the ST, extract the reduction drive gear assembly.

ST1 499737100 PULLER SET  
ST2 899524100 PULLER SET

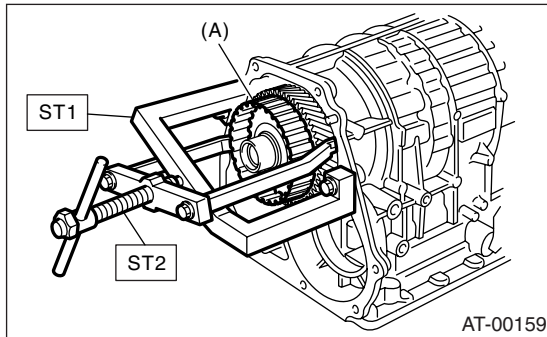

(A) Reduction drive gear assembly

### B: INSTALLATION

- 1) Install the reduction drive gear assembly.

#### NOTE:

Press-fit it to the bottom of bearing shoulder completely.

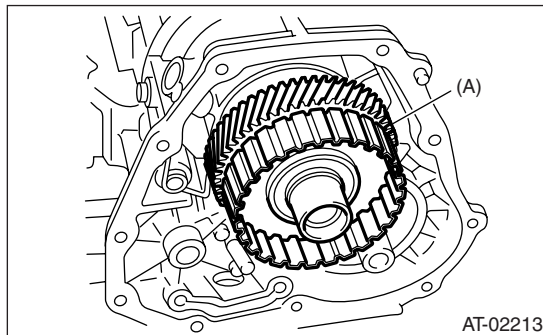

(A) Reduction drive gear assembly

- 2) Install the reduction driven gear. <Ref. to 4AT-80, INSTALLATION, Reduction Driven Gear.>
- 3) Join the transmission case and the extension case, and then install the rear vehicle speed sensor. <Ref. to 4AT-68, INSTALLATION, Extension Case.>
- 4) Install the transmission assembly to the vehicle. <Ref. to 4AT-40, INSTALLATION, Automatic Transmission Assembly.>

### C: DISASSEMBLY

- 1) Take out the seal ring.

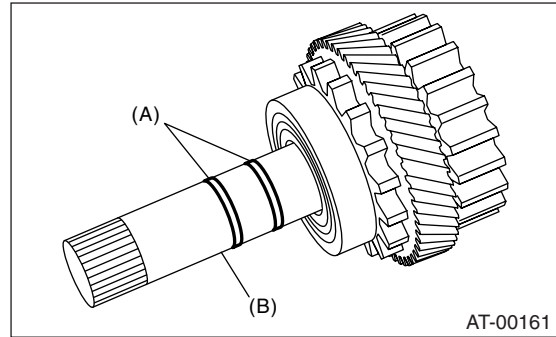

(A) Seal ring  
(B) Reduction drive shaft

- 2) Remove the ball bearing using ST.  
ST 498077600 REMOVER

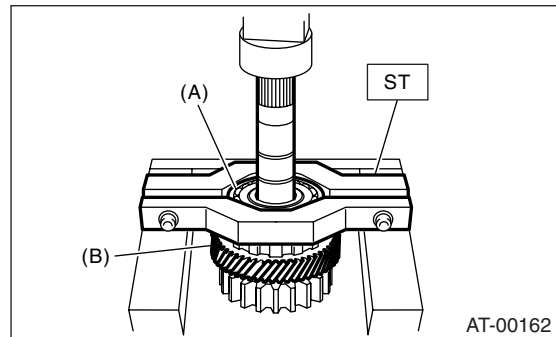

(A) Ball bearing  
(B) Reduction drive gear

- 3) Apply vaseline to the outer surface of seal ring and shaft groove.

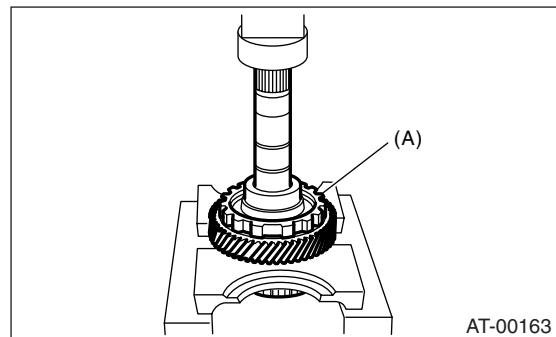

(A) Reduction drive gear

## D: ASSEMBLY

- 1) Press-fit the reduction drive gear to shaft.
- 2) Press-fit the new ball bearing into reduction drive gear.
- 3) Apply vaseline to the outer surface of new seal ring and shaft groove.
- 4) Install the seal ring.

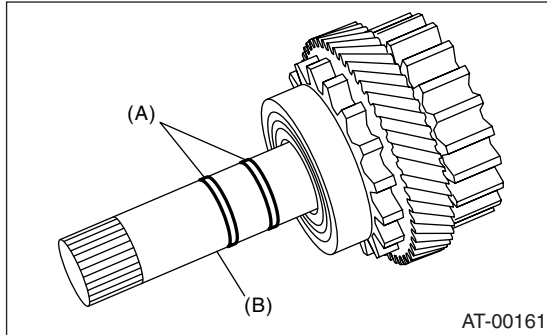

- (A) Seal ring  
(B) Reduction drive shaft

## E: INSPECTION

- Rotate the bearing by hand, make sure it rotates smoothly.
- Make sure there are no holes, bending damage or other foreign materials on each parts.
- Inspect the extension end play, and adjust it to the standard value. <Ref. to 4AT-76, ADJUSTMENT, Transfer Clutch.>