

Center Differential Carrier

AUTOMATIC TRANSMISSION

31.Center Differential Carrier

A: REMOVAL

- 1) Remove the transmission assembly from vehicle body. <Ref. to 4AT-37, REMOVAL, Automatic Transmission Assembly.>
- 2) Remove the rear wheel speed sensor, and separate the extension case from transmission case. <Ref. to 4AT-68, REMOVAL, Extension Case.>
- 3) Extract the rear drive shaft. <Ref. to 4AT-79, REMOVAL, Rear Drive Shaft.>
- 4) Using the special tools, pull out the center differential carrier assembly.

ST1 499737100 PULLER

ST2 899524100 PULLER SET

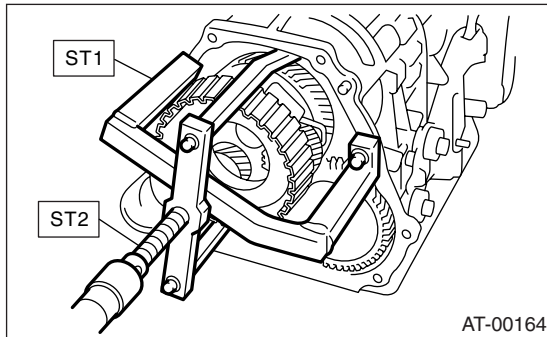

- 5) Pull out the shim(s) from transmission case.

B: INSTALLATION

- 1) Install the center differential assembly with shim.

NOTE:

Press-fit it to the bottom of bearing shoulder completely.

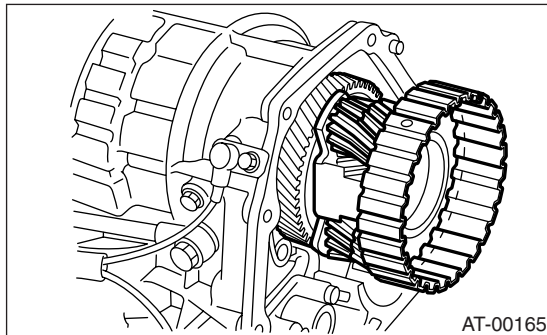

- 2) Insert the rear driveshaft assembly. <Ref. to 4AT-79, INSTALLATION, Rear Drive Shaft.>
- 3) Join the transmission case and the extension case, and then install the rear vehicle speed sensor. <Ref. to 4AT-68, INSTALLATION, Extension Case.>
- 4) Install the transmission assembly to the vehicle. <Ref. to 4AT-40, INSTALLATION, Automatic Transmission Assembly.>

C: DISASSEMBLY

- 1) Remove the seal ring.

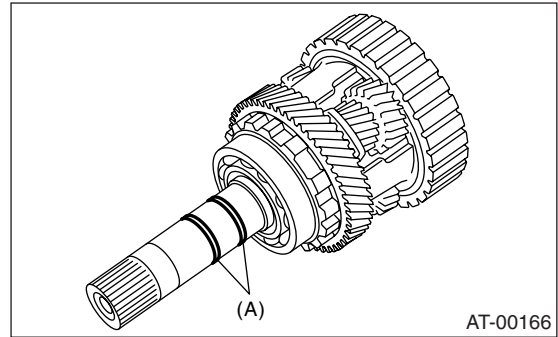

(A) Seal ring

- 2) Using a press and ST, remove the ball bearing.
ST 498077600 REMOVER

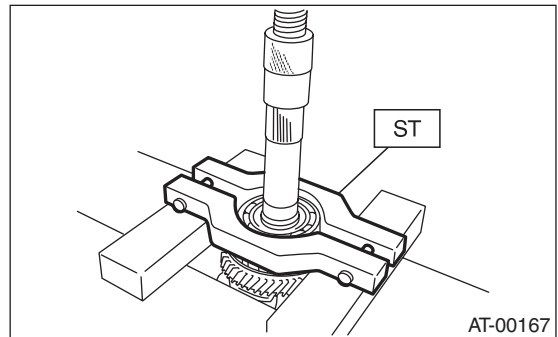

- 3) Remove the snap ring, and pull out the shaft from center differential assembly.

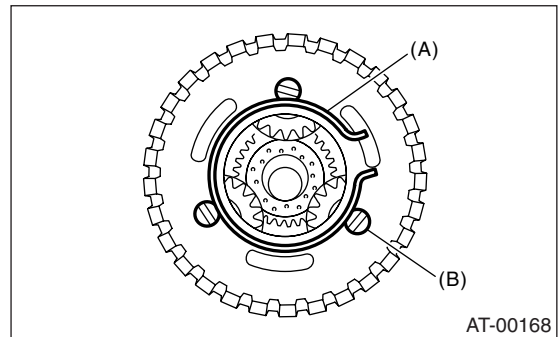

(A) Snap ring

(B) Shaft

- 4) Remove the thrust washers, pinion gears and washers from center differential assembly.

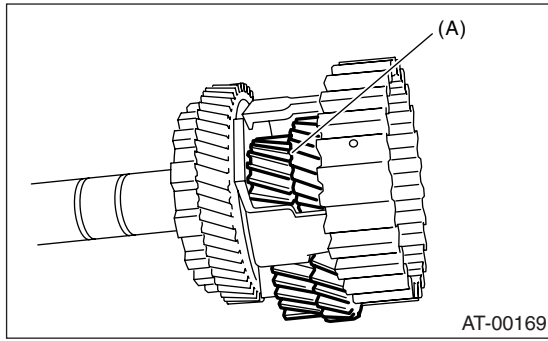

(A) Pinion gear

- 5) Pull out the intermediate shaft and thrust bearing.

D: ASSEMBLY

- 1) Install the thrust washer onto intermediate shaft.
- 2) Install the thrust bearing onto intermediate shaft.
- 3) Install the pinion gears and washers.
- 4) Insert the shaft into the center differential assembly.
- 5) Install the snap ring.
- 6) Using a press, install a new ball bearing into the center differential assembly.

ST 498077000 REMOVER

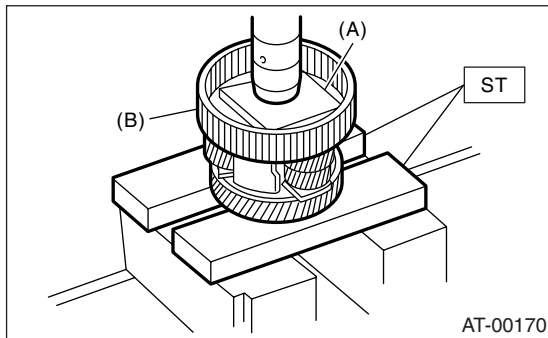

(A) Plate
(B) Center differential carrier

- 7) Apply vaseline onto the seal ring outer surface and shaft grooves.
- 8) Install a new seal ring.

E: INSPECTION

- Make sure there are no holes, cutting damage or other foreign materials on each parts.
- Inspect the extension end play, and adjust it to within the standard value. <Ref. to 4AT-76, VTD MODEL, ADJUSTMENT, Transfer Clutch.>