

38. Transmission Control Device

A: REMOVAL

- 1) Remove the transmission assembly from vehicle body. <Ref. to 4AT-37, REMOVAL, Automatic Transmission Assembly.>
- 2) Pull out the torque converter clutch assembly. <Ref. to 4AT-67, REMOVAL, Torque Converter Clutch Assembly.>
- 3) Remove the input shaft.
- 4) Lift-up the lever on the rear side of transmission harness connector, and then disconnect it from the stay.
- 5) Disconnect the air breather hose. <Ref. to 4AT-65, REMOVAL, Air Breather Hose.>
- 6) Disconnect the inhibitor switch connector from the stay.
- 7) Wrap vinyl tape around the nipple attached to the air breather hose.
- 8) Remove the pitching stopper bracket.
- 9) Remove the inhibitor switch.

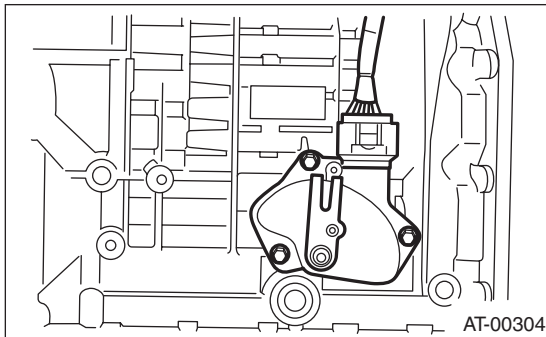

- 10) Remove the control valve body assembly. <Ref. to 4AT-56, REMOVAL, Control Valve Body.>
- 11) Pull out the manual plate spring pin.

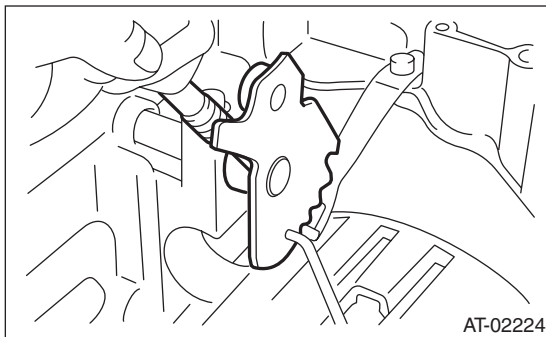

- 12) Remove the bolts securing the range select lever, then remove the range select lever, manual plate and parking rod.

NOTE:

Be careful not to damage the lips of press-fitted oil seal in the case.

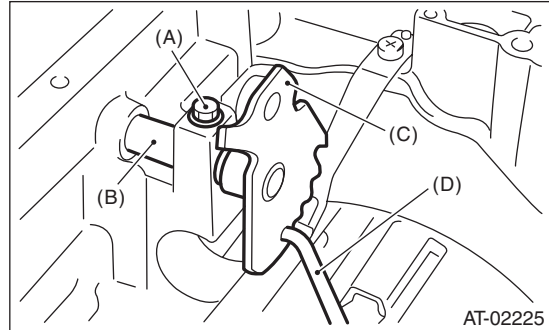

- (A) Bolt
- (B) Range select lever
- (C) Manual plate
- (D) Parking rod

- 13) Remove the detention spring.

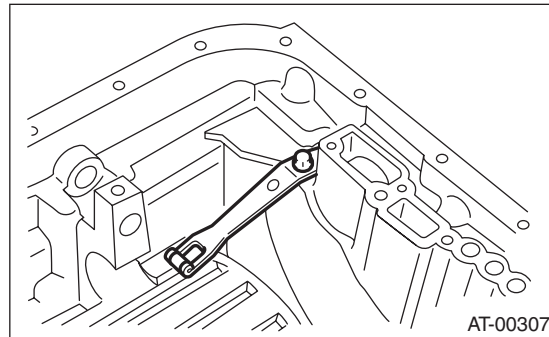

B: INSTALLATION

- 1) Install the detention spring to the transmission case.

Tightening torque:

6 N·m (0.6 kgf-m, 4.4 ft-lb)

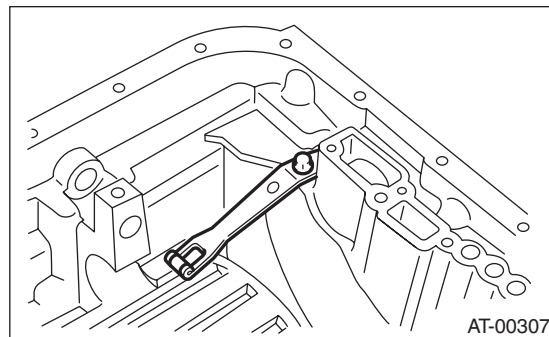

Transmission Control Device

AUTOMATIC TRANSMISSION

2) Insert the range select lever, and then tighten the bolt.

Tightening torque:

6 N·m (0.6 kgf-m, 4.4 ft-lb)

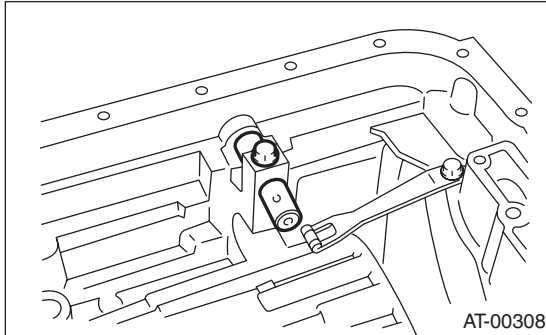

3) Insert the manual plate and parking rod.

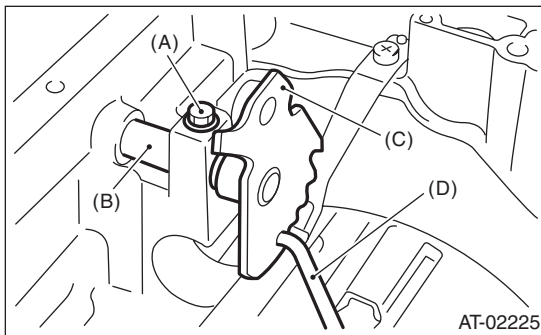

- (A) Bolt
- (B) Range select lever
- (C) Manual plate
- (D) Parking rod

4) Insert the spring pin to the manual plate.

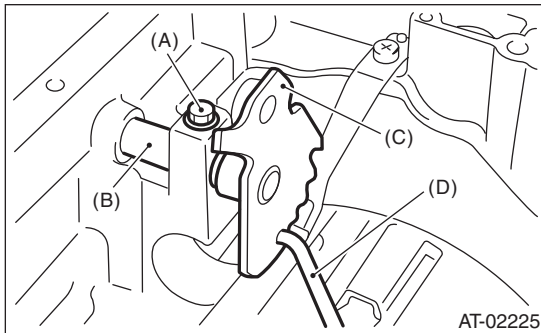

5) Install the oil pan and the control valve assembly. <Ref. to 4AT-57, INSTALLATION, Control Valve Body.>

6) Turn over the transmission case to its original position.

7) Install the pitching stopper bracket.

Tightening torque:

41 N·m (4.2 kgf-m, 30.4 ft-lb)

8) Install and adjust the inhibitor switch. <Ref. to 4AT-47, Inhibitor Switch.>

9) Insert the inhibitor switch and transmission connector to the stay.

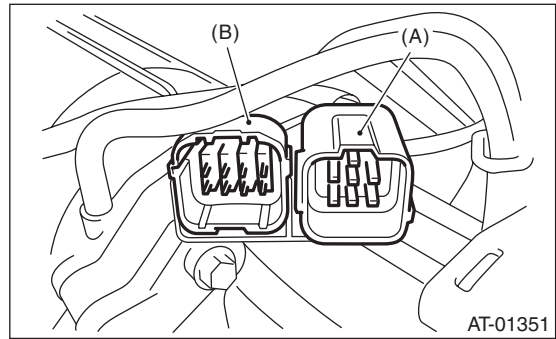

- (A) Transmission harness
- (B) Inhibitor switch harness

10) Install the air breather hose. <Ref. to 4AT-65, INSTALLATION, Air Breather Hose.>

11) Insert the input shaft while rotating it lightly by hand, and then check the amount of protrusion.

Normal protrusion A:

50 — 55 mm (1.97 — 2.17 in)

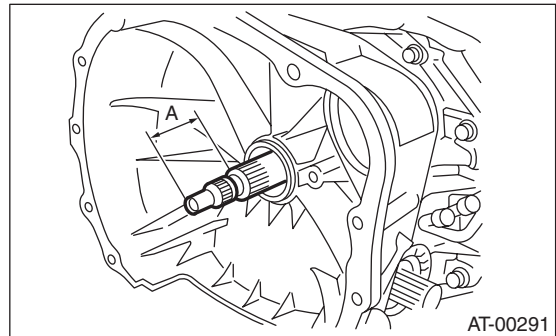

12) Install the torque converter clutch assembly. <Ref. to 4AT-67, INSTALLATION, Torque Converter Clutch Assembly.>

13) Install the transmission assembly to the vehicle. <Ref. to 4AT-40, INSTALLATION, Automatic Transmission Assembly.>

C: INSPECTION

Make sure that the manual lever and detention spring are not worn or otherwise damaged.