

4. Select Lever

A: REMOVAL

- 1) Set the vehicle on a lift.
- 2) Disconnect the ground cable from the battery.
- 3) Set the select lever to "N" range.
- 4) Lift-up the vehicle.
- 5) Remove the rear exhaust pipe and muffler.

Non-turbo model

<Ref. to EX (H4SO)-8, REMOVAL, Rear Exhaust Pipe.> <Ref. to EX (H4SO)-9, REMOVAL, Muffler.>

Turbo model

<Ref. to EX(H4DOTC)-13, REMOVAL, Rear Exhaust Pipe.> <Ref. to EX(H4DOTC)-15, REMOVAL, Muffler.>

- 6) Disconnect the cable from range select lever and then remove the cable bracket.

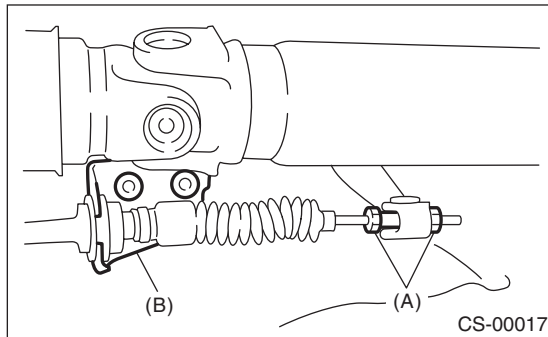

- (A) Adjusting nut
(B) Cable bracket

- 7) Lower the vehicle.
- 8) Remove the console box. <Ref. to EI-38, REMOVAL, Console Box.>
- 9) Disconnect the connectors, and then remove the four bolts to take out the select lever assembly from vehicle body.

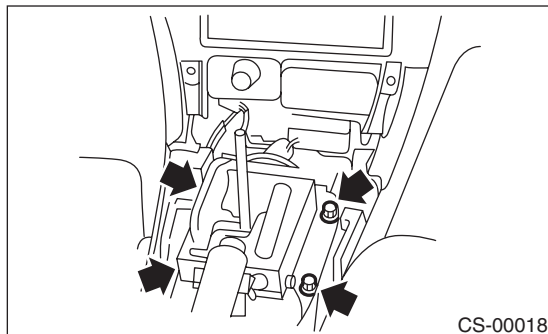

B: INSTALLATION

- 1) Mount the select lever onto the vehicle body.
- 2) Tighten the four bolts at the prescribed torque, then connect the connector.

Tightening torque:

13 N·m (1.3 kgf-m, 9.4 ft-lb)

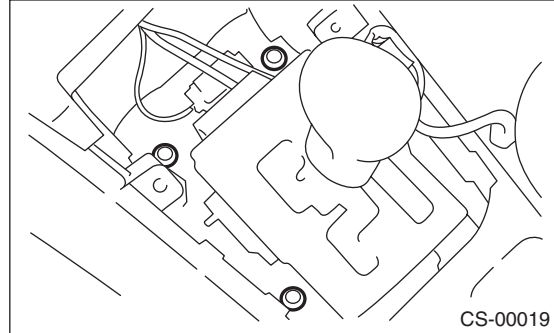

- 3) Install the console box. <Ref. to EI-36, INSTALLATION, Glove Box.>
- 4) Set the select lever to "N" range.
- 5) Lift-up the vehicle.
- 6) Set the select lever to "N" range.
- 7) Insert the thread portion of the other inner cable and into connector hole of the select lever, and fix the other outer cable end to bracket.

Tightening torque:

18 N·m (1.8 kgf-m, 13.0 ft-lb)

- 8) Adjust the select cable position. <Ref. to CS-27, ADJUSTMENT, Select Cable.>
- 9) After completion of fitting, make sure that the select lever operates smoothly all across the operating range.
- 10) Install the rear exhaust pipe and muffler.

Non-turbo model

<Ref. to EX (H4SO)-8, INSTALLATION, Rear Exhaust Pipe.> <Ref. to EX (H4SO)-9, INSTALLATION, Muffler.>

Turbo model

<Ref. to EX(H4DOTC)-14, INSTALLATION, Rear Exhaust Pipe.> <Ref. to EX(H4DOTC)-15, INSTALLATION, Muffler.>

- 11) Inspect the following items. If the following inspection reveals problems, adjust the select cable and inhibitor switch. <Ref. to CS-27, ADJUSTMENT, Select Cable.> <Ref. to 4AT-47, ADJUSTMENT, Inhibitor Switch.>

- (1) Engine starts when the select lever is in "P" and "N" range, but not in other range.
- (2) Back-up light illuminates when the select lever is in the "R" range, but not in other range.
- (3) Select lever and indicator positions are matched.

Select Lever

CONTROL SYSTEMS

C: DISASSEMBLY

- 1) Remove the packing.
- 2) Remove the grip.
- 3) Remove the indicator light, and then remove the indicator cover.

NOTE:

Be careful not to damage the indicator light during removal.

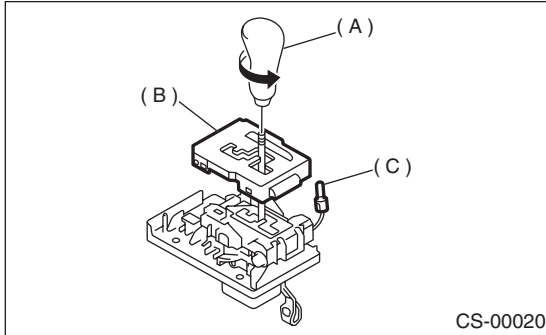

- (A) Grip
- (B) Indicator cover
- (C) Indicator light

- 4) Remove the blind.
- 5) Remove the cover.

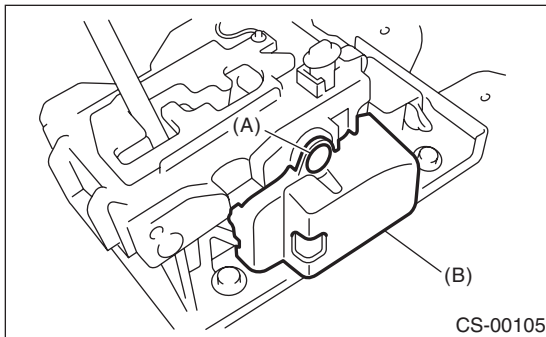

- (A) Clip
- (B) Cover

- 6) Remove the clips and then remove the guide plate.

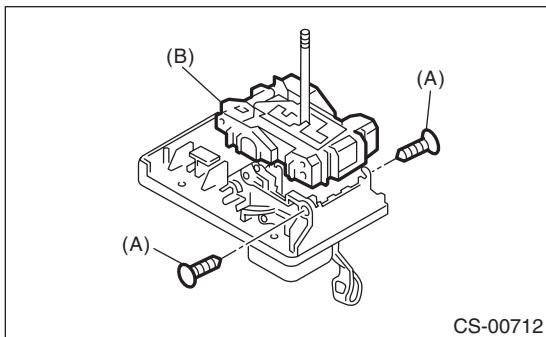

- (A) Clip
- (B) Guide plate

- 7) Remove the clamp and remove the shift lock solenoid.

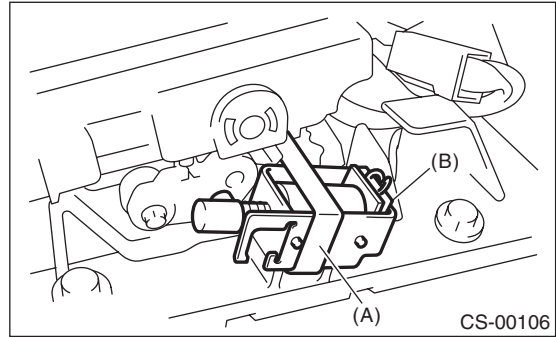

- (A) Clamp
- (B) Shift lock solenoid

- 8) Remove the bolts which secure the lock plate B.

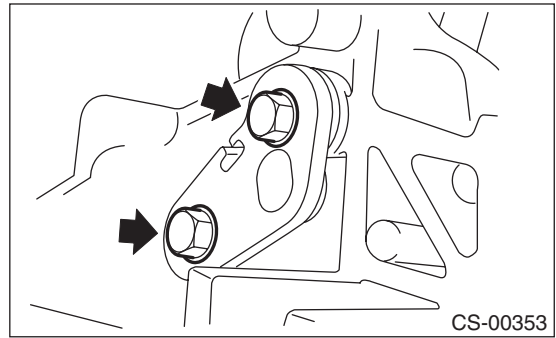

- 9) Remove the lock plates A, B, and C and the bushing.

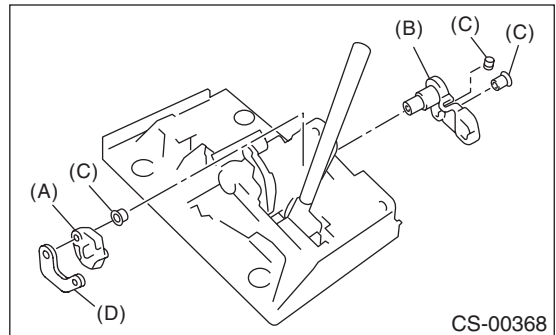

- (A) Lock plate A
- (B) Lock plate B
- (C) Bushing
- (D) Lock plate C

10) Remove the cushion plate.

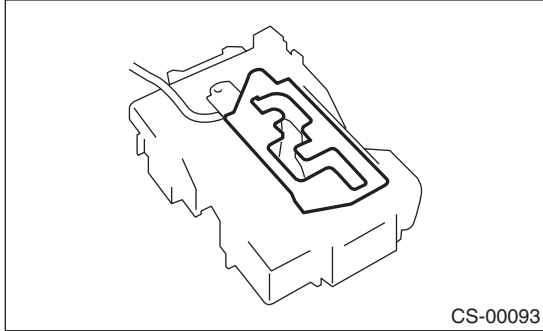

11) Remove the "P" range switch.

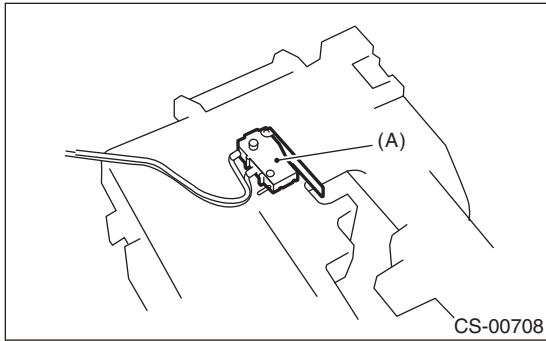

(A) "P" range switch

12) Remove the grommet and then extract the spring pin.

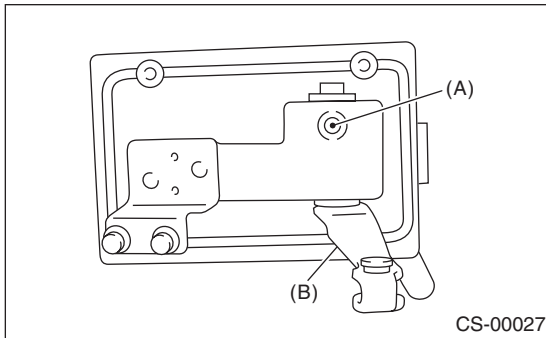

(A) Spring pin
(B) Select lever arm

13) Remove the select lever arm and then remove the select lever COMPL from the plate.

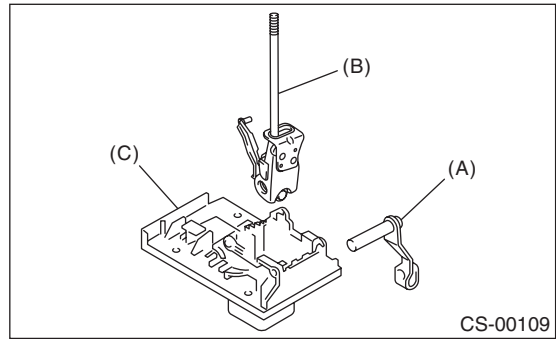

(A) Select lever arm
(B) Selector lever COMPL
(C) Plate

14) Remove the detent spring and remove the detent arm.

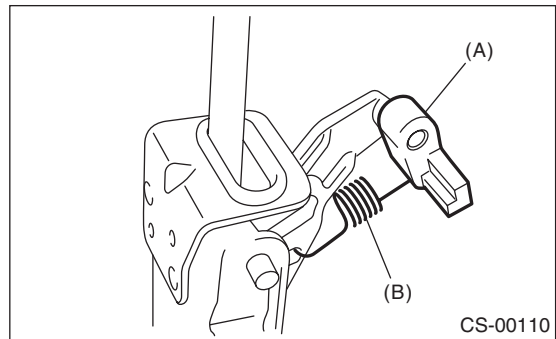

(A) Detent arm
(B) Detent spring

15) Remove the select lever COMPL bushing from bracket.

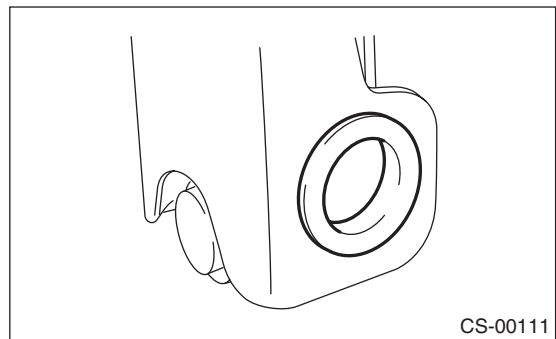

Select Lever

CONTROL SYSTEMS

16) Remove the bracket from select lever COMPL.

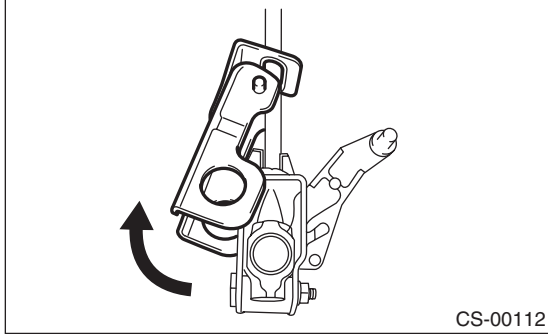

17) Remove the bushing from the bracket.

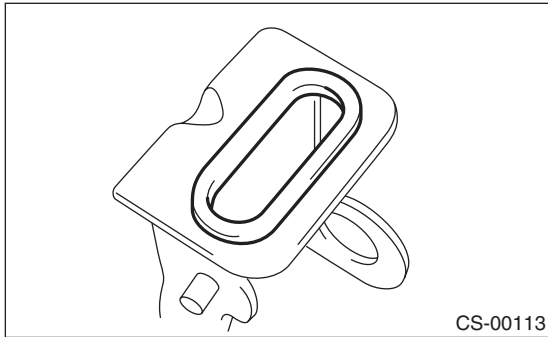

D: ASSEMBLY

- 1) Clean all the parts before assembly.
- 2) Apply grease [KOPR-KOTE (Part No. 003603001) or equivalent] to each part. <Ref. to CS-2, AT SELECT LEVER, COMPONENT, General Description.>

CAUTION:

Apply grease [SUNCALL GLO-244] to the axle of lock plate.

- 3) Assemble in the reverse order of disassembly.
- 4) After completion of fitting, transfer the select lever to the "1" range from "P" range, then check whether the select indicator and select lever match, and whether the pointer and position mark match and check the operating force.

E: INSPECTION

- 1) Inspect the removed parts by comparing with new parts for deformation, damage and wear. Repair or replace if defective.
- 2) Confirm the select lever COMPL operating condition before assembling. Normal if it operates smoothly.