

2. Transmission Gear Oil

A: INSPECTION

- 1) Park the vehicle on a level surface.
- 2) Turn the ignition switch to OFF, and wait until the engine cools.
- 3) Remove the oil level gauge and wipe it clean.
- 4) Reinsert the level gauge all the way. Be sure that the level gauge is correctly inserted and in the proper direction.
- 5) Pull out the oil level gauge again and check the oil level. If it is below the lower level, add oil through the oil level gauge hole to bring the level up to the upper level.

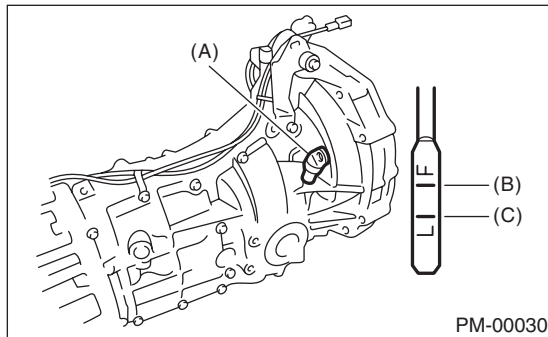

- (A) Oil level gauge
- (B) Upper level
- (C) Lower level

B: REPLACEMENT

- 1) Pull out the oil level gauge.
- 2) Lift-up the vehicle.
- 3) Drain transmission gear oil completely.

CAUTION:

- Immediately after the engine has been running, the transmission gear oil is hot. Be careful not to burn yourself.
 - Be careful not to spill the transmission gear oil on exhaust pipe, to prevent emitting smoke or causing a fire. If differential gear oil is spilled on the exhaust pipe, wipe it off completely.
- 4) Use a new gasket, and tighten the transmission gear oil drain plug.

Tightening torque:

44 N·m (4.5 kgf-m, 32.5 ft-lb) (Aluminum gasket)

70 N·m (7.1 kgf-m, 51.6 ft-lb) (Copper gasket)

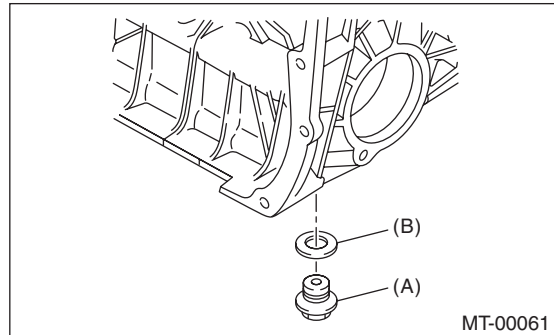

- (A) Drain plug
- (B) Gasket

- 5) Lower the vehicle.
- 6) Pour the gear oil into the gauge hole.

RECOMMENDED GEAR OIL

Use GL-5 or the equivalent.

Gear oil capacity

3.5 ℓ (3.7 US qt, 3.1 Imp qt)

- 7) Measure the transmission gear oil level to check that it is within specifications.

CAUTION:

When inserting the level gauge into the transmission, align the protrusion on the top part of the level gauge with the notch in the gauge hole.