

4. Transmission Mounting System

A: REMOVAL

1. PITCHING STOPPER

- 1) Disconnect the ground cable from the battery.
- 2) Remove the air intake duct and cleaner case.
- 3) Remove the air intake duct. (Non-turbo model)
- 4) Remove the air intake chamber. (Non-turbo model) <Ref. to IN (H4SO)-6, REMOVAL, Air Intake Chamber.>
- 5) Remove the intercooler. (Turbo model) <Ref. to IN(H4DOTC)-11, REMOVAL, Intercooler.>
- 6) Remove the pitching stopper.

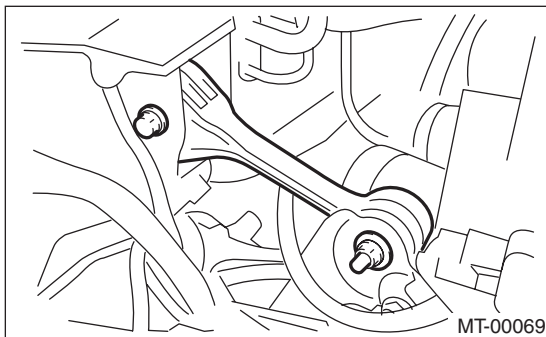

2. CROSSMEMBER AND CUSHION RUBBER

- 1) Disconnect the ground cable from the battery.
- 2) Jack-up the vehicle and support it with rigid racks.
- 3) Remove the front and center exhaust pipes. (Non-turbo model) <Ref. to EX (H4SO)-4, REMOVAL, Front Exhaust Pipe.> <Ref. to EX (H4SO)-7, REMOVAL, Center Exhaust Pipe.>
- 4) Remove the center exhaust pipe. (Turbo model) <Ref. to EX(H4DOTC)-8, REMOVAL, Center Exhaust Pipe.>
- 5) Remove the rear exhaust pipe and muffler.
- 6) Set the transmission jack under the transmission body.

CAUTION:

Always support the transmission case with a transmission jack.

- 7) Remove the rear crossmember.

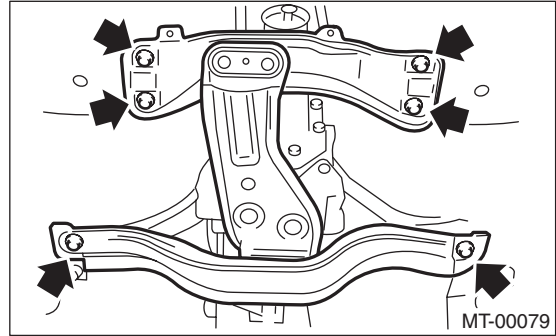

- 8) Remove the rear cushion rubber.

B: INSTALLATION

1. PITCHING STOPPER

- 1) Install the pitching stopper.

Tightening torque:

T1: 50 N·m (5.1 kgf-m, 36.9 ft-lb)

T2: 58 N·m (5.9 kgf-m, 43 ft-lb)

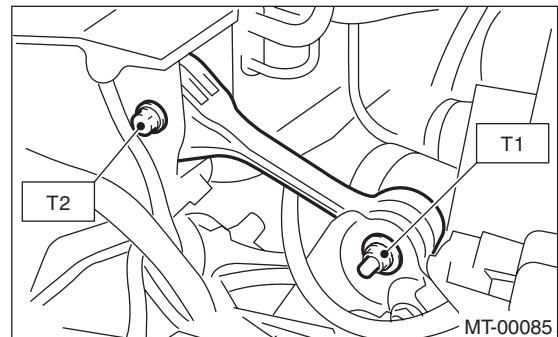

- 2) Install the air intake duct and air intake chamber. (Non-turbo model) <Ref. to IN (H4SO)-6, INSTALLATION, Air Intake Chamber.>
- 3) Install the intercooler. (Turbo model) <Ref. to IN(H4DOTC)-11, INSTALLATION, Intercooler.>
- 4) Connect the ground cable to the battery.

Transmission Mounting System

MANUAL TRANSMISSION AND DIFFERENTIAL

2. CROSSMEMBER AND CUSHION RUBBER

1) Install the rear cushion rubber.

Tightening torque:

35 N·m (3.6 kgf·m, 26 ft·lb)

2) Install the rear crossmember.

Tightening torque:

T1: 70 N·m (7.1 kgf·m, 51 ft·lb)

T2: 140 N·m (14.3 kgf·m, 103 ft·lb)

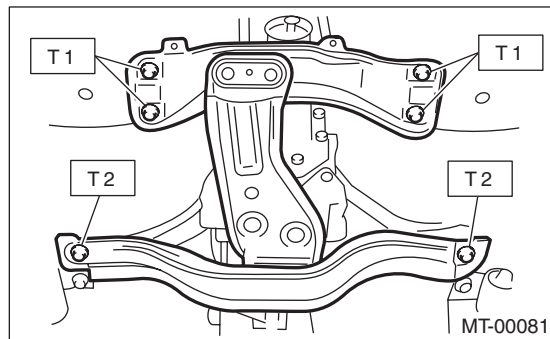

3) Remove the transmission jack.

4) Install the front and center exhaust pipe. (Non-turbo model)

<Ref. to EX (H4SO)-5, INSTALLATION, Front Exhaust Pipe.>

5) Install the center exhaust pipe. (Turbo model)
<Ref. to EX(H4DOTC)-9, INSTALLATION, Center Exhaust Pipe.>

6) Install the rear exhaust pipe and muffler.

C: INSPECTION

Perform the following inspection procedures, and repair or replace faulty parts.

1. PITCHING STOPPER

Make sure that the pitching stopper is not bent or damaged. Check that the rubber is not stiff, cracked or otherwise damaged.

2. CROSSMEMBER AND CUSHION RUBBER

Make sure that the crossmember is not bent or damaged. Check that the cushion rubber is not stiff, cracked, or otherwise damaged.