

# Differential Side Retainer Oil Seal

## MANUAL TRANSMISSION AND DIFFERENTIAL

### 6. Differential Side Retainer Oil Seal

#### A: INSPECTION

Check for leakage of gear oil from the differential side retainer oil seal. If there is an oil leak, replace the oil seal.

#### B: REPLACEMENT

- 1) Lift-up the vehicle.
- 2) Drain the differential gear oil from the differential oil drain plug.

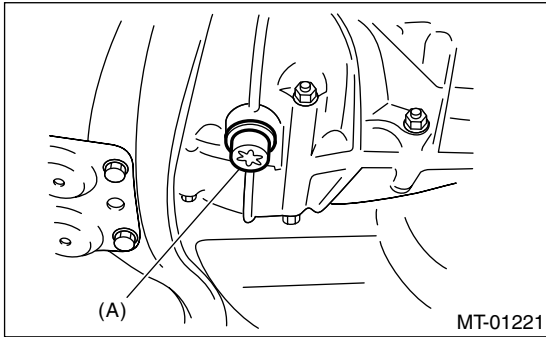

(A) Drain plug

- 3) Replace the gasket with a new part and tighten the differential oil drain plug.

#### Tightening torque:

**44 N·m (4.5 kgf·m, 32.5 ft·lb) (Aluminum gasket)**

**70 N·m (7.1 kgf·m, 51.6 ft·lb) (Copper gasket)**

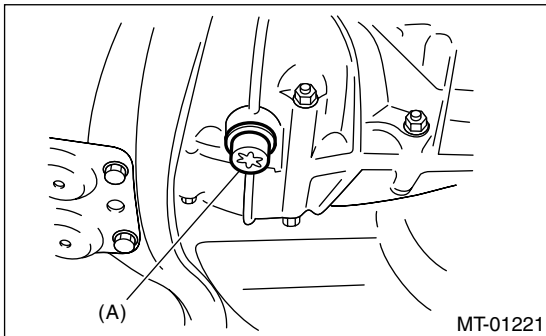

(A) Drain plug

- 4) Remove the front and center exhaust pipes. (Non-turbo model) <Ref. to EX (H4SO)-4, REMOVAL, Front Exhaust Pipe.>
- 5) Separate the front drive shaft from the transmission. <Ref. to DS-29, REMOVAL, Front Drive Shaft.>
- 6) Remove the differential side retainer oil seal using a screw driver wrapped with vinyl tape etc.

- 7) Using the ST, install the differential side retainer oil seal by lightly tapping with a hammer.

ST 18675AA000 DIFFERENTIAL SIDE OIL SEAL INSTALLER

#### NOTE:

Apply oil to the oil seal lips.

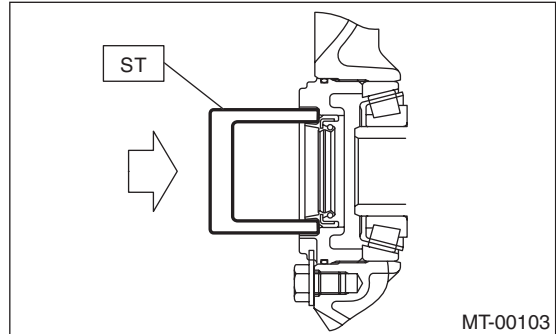

- 8) Install the front drive shaft. <Ref. to DS-30, INSTALLATION, Front Drive Shaft.>

- 9) Install the front and center exhaust pipe. (Non-turbo model) <Ref. to EX (H4SO)-5, INSTALLATION, Front Exhaust Pipe.>

- 10) Lower the vehicle.

- 11) Pour gear oil through the gauge hole. <Ref. to 5MT-25, REPLACEMENT, Transmission Gear Oil.>