

## 11. Transfer Drive Gear

### A: REMOVAL

- 1) Remove the manual transmission assembly from the vehicle. <Ref. to 5MT-26, REMOVAL, Manual Transmission Assembly.>
- 2) Remove the back-up light switch and neutral position switch. <Ref. to 5MT-35, REMOVAL, Switches and Harness.>
- 3) Remove the transfer case together with the extension case assembly. <Ref. to 5MT-39, REMOVAL, Transfer Case and Extension Case Assembly.>
- 4) Remove the extension case assembly.
- 5) Remove the transfer driven gear.
- 6) Remove the transfer drive gear.

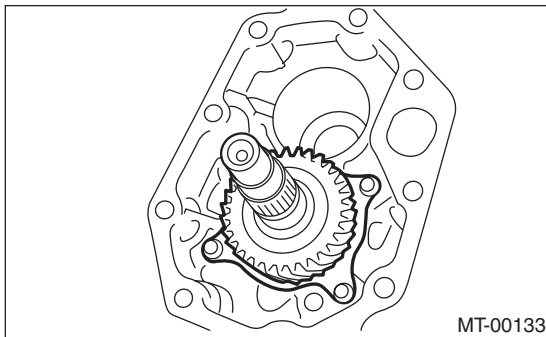

### B: INSTALLATION

- 1) Attach the transfer drive gear.

#### *Tightening torque:*

**26 N·m (2.7 kgf·m, 20 ft·lb)**

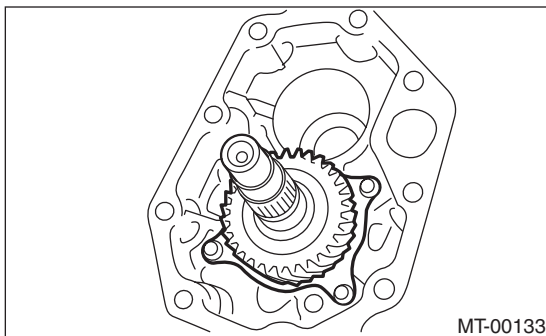

- 2) Install the transfer driven gear.
- 3) Install the extension case assembly.
- 4) Install the transfer case and the extension case assembly. <Ref. to 5MT-39, INSTALLATION, Transfer Case and Extension Case Assembly.>
- 5) Install the back-up light switch and the neutral position switch. <Ref. to 5MT-35, INSTALLATION, Switches and Harness.>
- 6) Install the manual transmission assembly to the vehicle. <Ref. to 5MT-28, INSTALLATION, Manual Transmission Assembly.>

### C: DISASSEMBLY

- 1) Remove the snap ring.

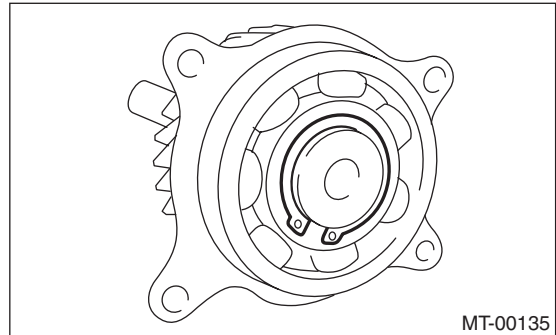

- 2) Remove the ball bearing.

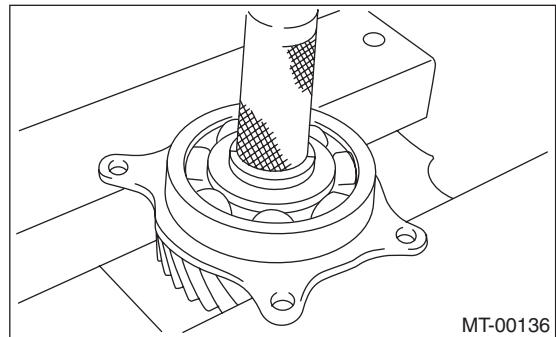

### D: ASSEMBLY

- 1) Set the ST against the inner race of the bearing, and install the drive shaft.

ST 398177700 INSTALLER

#### **CAUTION:**

**Do not apply a load in excess of 10 kN (1 ton, 1.1 US ton, 1.0 Imp ton).**

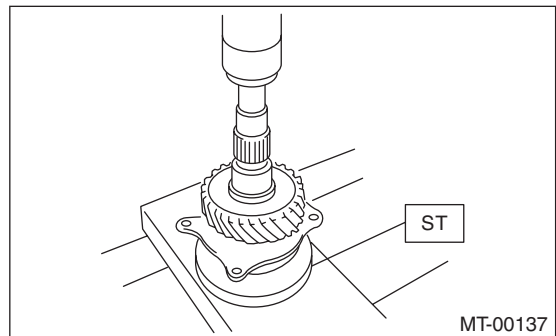

- 2) Install the snap ring on the transfer drive shaft.
- 3) Inspect the clearance between the snap ring and the ball bearing. <Ref. to 5MT-44, INSPECTION, Transfer Drive Gear.>

# Transfer Drive Gear

## MANUAL TRANSMISSION AND DIFFERENTIAL

---

### E: INSPECTION

#### 1) Bearing

Replace the bearings in the following cases.

- In case of broken or rusty bearings
- In case of worn or damaged bearings
- In the case that the bearing fails to turn smoothly or makes an abnormal noise when turned, even after gear oil lubrication.

#### 2) Drive gear

Replace the drive gear in following case.

- If the drive gear tooth surface and shaft are excessively broken or damaged.

3) Measure the clearance between snap ring and inner race of ball bearing with a thickness gauge.

#### **Clearance:**

**0.01 — 0.15 mm (0.0004 — 0.0059 in)**

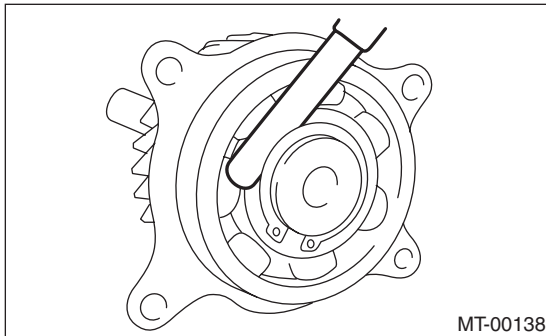

If the measured value is not within the specification, select a suitable snap ring from the table below and replace.

Snap ring (Outer-30)	
Part No.	Thickness mm (in)
805030041	1.53 (0.0602)
805030042	1.65 (0.0650)
805030043	1.77 (0.0697)