

Reverse Check Sleeve

MANUAL TRANSMISSION AND DIFFERENTIAL

14. Reverse Check Sleeve

A: REMOVAL

- 1) Remove the manual transmission assembly from the vehicle. <Ref. to 5MT-26, REMOVAL, Manual Transmission Assembly.>
- 2) Remove the transfer case together with the extension case assembly. <Ref. to 5MT-39, REMOVAL, Transfer Case and Extension Case Assembly.>
- 3) Remove the shifter arm.
- 4) Remove the plug, gasket, reverse accent spring, and reverse check ball.

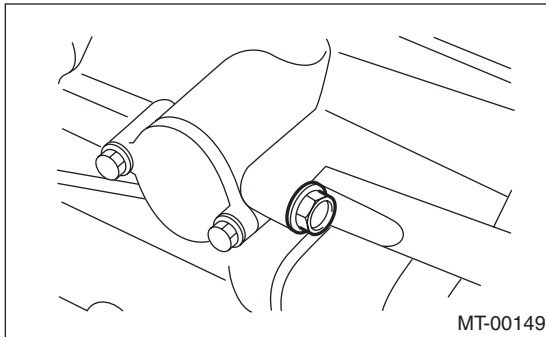

- 5) Remove the reverse check sleeve.

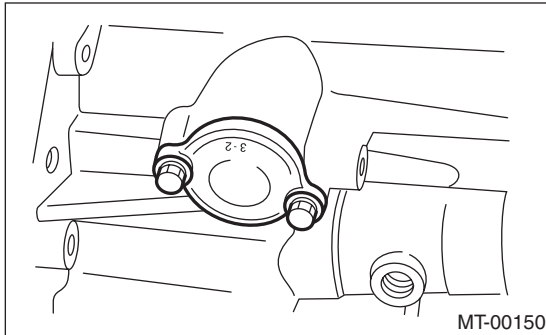

B: INSTALLATION

- 1) Install the reverse check sleeve.

Tightening torque:

6.4 N·m (0.65 kgf-m, 4.7 ft-lb)

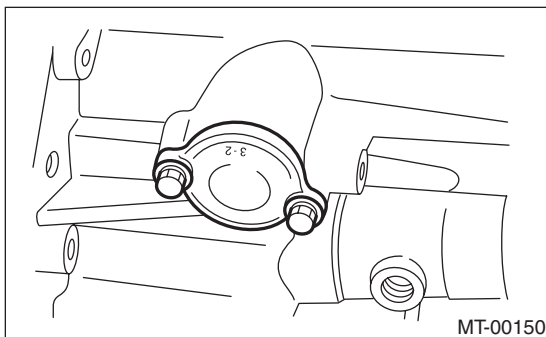

- 2) Install the reverse check ball, reverse accent spring, gasket and plug to transfer case.

Tightening torque:

9.75 N·m (1.0 kgf-m, 7.2 ft-lb)

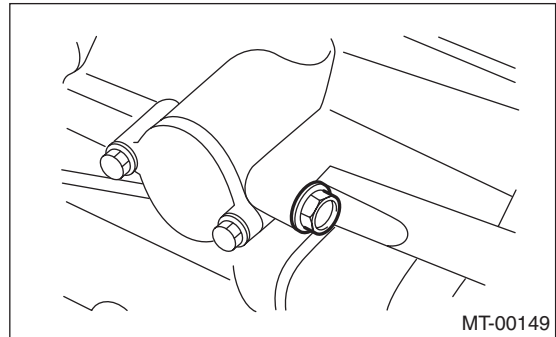

- 3) Attach the shifter arm to the transfer case assembly.
- 4) Install the transfer case together with the extension case assembly. <Ref. to 5MT-39, INSTALLATION, Transfer Case and Extension Case Assembly.>
- 5) Install the manual transmission assembly to the vehicle. <Ref. to 5MT-28, INSTALLATION, Manual Transmission Assembly.>

Reverse Check Sleeve

C: DISASSEMBLY

1) Cover the reverse check sleeve with a rag, and remove the snap ring using a screwdriver.

NOTE:

If deformed or worn, replace with a new snap ring.

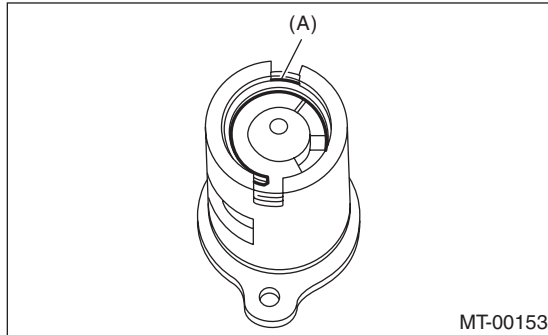

(A) Snap ring

2) Remove the reverse check plate, reverse check spring, reverse check cam, return spring (5th-Rev), reverse accent shaft, return spring cap and return spring (1st-2nd).

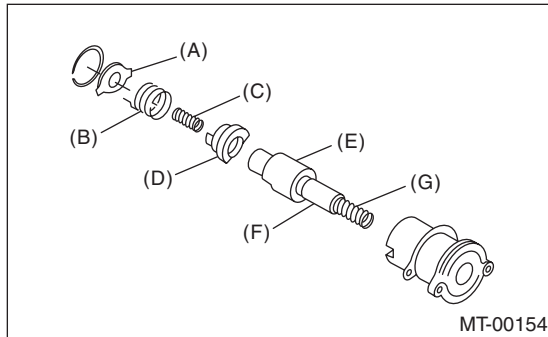

- (A) Reverse check plate
- (B) Reverse check spring
- (C) Return spring (5th-Rev)
- (D) Reverse check cam
- (E) Reverse accent shaft
- (F) Return spring cap
- (G) Return spring (1st-2nd)

3) Remove the O-ring.

NOTE:

- For the reverse check sleeve, make sure only to use an undamaged O-ring with no scratches on it.
- Be careful not to damage the adjusting shim between reverse check sleeve assembly and the case.

D: ASSEMBLY

1) Install the return spring (1st-2nd), return spring cap, reverse accent shaft, check cam, return spring and check spring to the reverse check sleeve.

NOTE:

Be sure to position the bent section of reverse check spring to fit in the groove of the check cam.

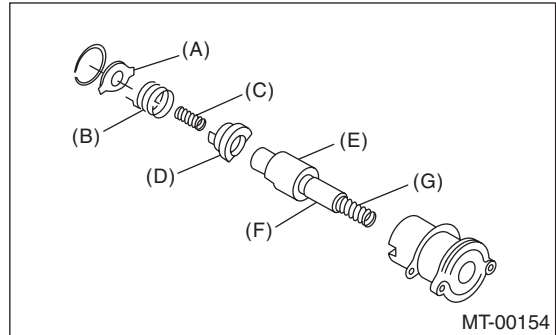

- (A) Reverse check plate
- (B) Reverse check spring
- (C) Return spring (5th-Rev)
- (D) Reverse check cam
- (E) Reverse accent shaft
- (F) Return spring cap
- (G) Return spring (1st-2nd)

2) Hook the bent section of reverse check spring over reverse check plate.

3) Rotate the cam so that the protrusion of the reverse check cam comes to the opening of the plate.

4) With cam held in that position, install the plate onto the reverse check sleeve and hold in place with the snap ring.

5) Position the new O-ring in the groove of sleeve.

Reverse Check Sleeve

MANUAL TRANSMISSION AND DIFFERENTIAL

E: INSPECTION

- Make sure the cutout of the reverse accent shaft is aligned with the opening in the reverse check sleeve.
 - Turn the cam by hand to check for smooth rotation.
 - Move the cam and shaft all the way toward the plate, and make sure it releases.
- If the cam does not return properly, replace the reverse check spring. If the shaft does not return, check for scratches on the inner surface of sleeve. If the sleeve is in good order, replace the spring.

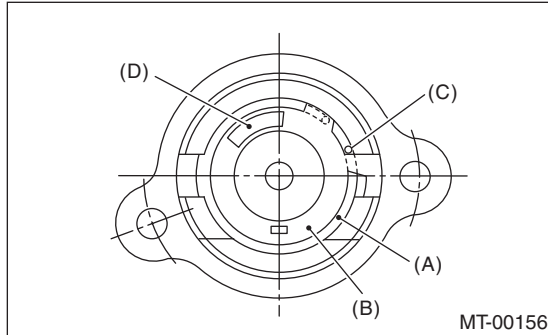

- (A) Snap ring
- (B) Reverse check plate
- (C) Checking spring
- (D) Check cam

- Select a suitable reverse accent shaft and reverse check plate. <Ref. to 5MT-50, ADJUSTMENT, Reverse Check Sleeve.>

F: ADJUSTMENT

1. NEUTRAL POSITION ADJUSTMENT

- 1) Shift the gear into 3rd gear position.
- 2) Because of the return spring, until the arm contacts the stopper the shifter arm will feel lighter moving towards 1st/2nd gear and heavier towards the reverse gear.
- 3) Make adjustment so that the heavy stroke (reverse side) is a little heavier than the lighter stroke (1st/2nd side).
- 4) To adjust, remove the bolts holding the reverse check sleeve assembly to the case, and move the sleeve assembly outward, then place an adjustment shim (0 to 1 ea.) between the sleeve assembly and the case to adjust the clearance.
- 5) Be careful not to damage the O-ring when placing shims.

NOTE:

- When the shim is removed, the neutral position will move closer to reverse; when the shim is added, the neutral position will move closer to 1st gear.

- If it is not possible to adjust the clearance with only shims, replace the reverse accent shaft and re-adjust.

Adjusting shim	
Part No.	Thickness mm (in)
32190AA000	0.15 (0.0059)
32190AA010	0.30 (0.0118)

Reverse accent shaft		
Part No.	Mark	Remarks
32188AA130	S	Neutral position is closer to 1st gear.
32188AA140	T	Standard
32188AA150	U	Neutral position is closer to reverse gear.

2. REVERSE CHECK PLATE ADJUSTMENT

- 1) Shift the shifter arm to "5th" and then to reverse to see if the reverse check mechanism operates properly.
- 2) Also check to see if the arm returns to neutral when released from the reverse position. If the arm does not return properly, replace the reverse check plate.

Reverse check plate			
Part No.	(A): No.	Angle θ	Remarks
32189AA000	0	28°	Arm stops closer to 5th gear.
32189AA010	1	31°	Arm stops closer to 5th gear.
32189AA020	2	34°	Arm stops in the center.
32189AA030	3	37°	Arm stops closer to reverse gear.
32189AA040	4	40°	Arm stops closer to reverse gear.

